

# Quick Installation Guide

## 1.8" Hard Disk Drives ATA/IDE

**Models:** HTC424020F7AT00, HTC424040F9AT00

### Handling Precautions

1. *Do not press on the drive.* Hold the drive by the sides only, do not apply any force to the drive during handling or installation
2. Always handle the drive with care to prevent damage from shock, vibration or electrostatic discharge (ESD). Do not touch the Printed Circuit Board (PCB).
3. *Electrostatic Discharge.* Static electricity can damage the drive. Before handling the drive, touch an unpainted metal surface for a few seconds to drain any static electricity from your body.
4. Keep the original packaging and static -protective bag in case the drive has to be returned.



### Quick Installation Procedure

It is advisable to backup all data before proceeding with the installation. If your system BIOS cannot handle large capacity drives (over 540MB, or 8.4GB) you may need to use a disk overlay program such as Ontrack's Disk Manager software. Contact your Hitachi supplier or the local Hitachi office.

### Dimensions / Screw locations

Check that the dimensions and screw hole locations are correct for your system.

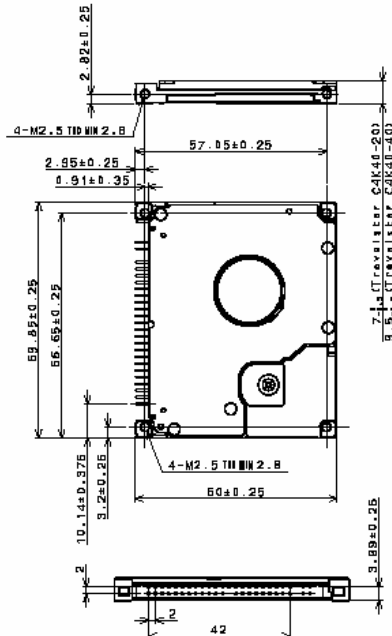

### Setting the jumpers

1. In a one drive system configure the new drive as a Master with no jumpers attached.
2. In a two drive system, one drive must be designated as Master and the other as Slave.
3. When installing the new drive as a Slave set the jumper to position A-B. Check the Master drive to determine if a jumper change is required to indicate Slave present.
4. Before selecting Cable Select (CSEL D-B) consult your system manual to see if this is supported.

#### 1) DRIVE 0 (or Master)

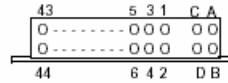

If all of pins A,B, D are open, the drive is DRIVE 0(or Master).

#### 2) DRIVE 1 (or Slave)

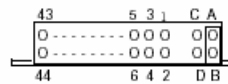

If jumper Position A-B is used, the drive is DRIVE 1 (or Slave).

#### 3) CSEL Selection

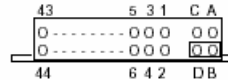

If jumper Position B-D is used, DRIVE 0 or DRIVE 1 setting is determined by the condition of CSEL signal (pin# 28).

### Attaching the drive

1. Turn off the computer, unplug the power cord and remove the notebook battery.
2. Open the cover.
3. Match pin 1 of the 44 pin cable, usually denoted by a red stripe, to pin 1 of the drive interface connector, shown above.
4. Mount the drive securely using 4 M3 (metric) screws with a maximum screw length of 2.5 mm.

### Configuring your computer

1. Reinstall the notebook battery, plug in the power cord and turn on the computer.
2. The computer may detect a configuration change and prompt you to proceed to the Setup screen.
3. If it does not, enter the Setup screen using the key selection. Refer to the onscreen instructions or the computer handbook.
4. Select "Auto Detect" for the new drive, if your system supports this feature. If it does not, select the "User Definable Type" and enter the parameters from the table.
5. If you cannot see the full capacity of the drive use Disk Manager.
6. Partition and Format the drive, then install your data. If, after complete installation, your system will not boot up, recheck all settings. If the system still fails to boot up, contact your supplier's

Model	Cylinders	Heads	Sectors	LZ	WPC	Capacity
All	16383	16	63	16383	16383	8.4GB+*

\* Maximum addressable capacity in CHS mode is 8.455 GB