

# IBM OEM STORAGE PRODUCTS

## Travelstar LP

### DBOA 2360, DBOA 2528, DBOA 2540 & DBOA 2720

These 2.5" disk drives from IBM provide up to 720 MB in a slim 12.5mm high package. Using the latest MR head technology IBM provides high performance drives particularly suited to the mobile computing market.

#### *Applications*

- \* High performance portable computers
- \* Non-IT - process control/fax
- \* Removable/secure storage units

#### Features

- \* 361/528/541/722 MB at (512 bytes/sector)
- \* IDE interface with DMA data transfer
  - Single word: mode 2 (8.3 MB/sec).
  - Multi word: mode 1 (11.1 MB/sec).
- \* PIO data transfer - mode 3 (11.1 MB/sec).
- \* Shock 500G (2ms) non op. All 6 axis mounting.
- \* Media data rate 26.9/39.54 Mbits/s (8 zones)
  - \* Rotational speed 4000 rpm.
- \* Average seek 13 milliseconds (Read).
- \* Magneto resistive heads.
- \* 64K Read Buffer
- \* 32KB Write
- \* ECC on the fly
- \* 0.95 watt idle power
- \* Power saving modes
- \* Spin up 2.3 sec (typical).

#### Benefits

- \* High capacity 2.5" drives.
- \* Popular interface with excellent performance
- \* Robust design for portable computing applications.
- \* Excellent data rate across disk surface
- \* High areal density, low component count.
- \* Fast access to data and improved throughput
- \* Low power for battery powered applications
- \* Fast recovery from standby.

#### *Electrical Connector Locations*

##### *Drive Address*

A jumper cable is available at the interface connector to determine the drive address. Using Cable Selection, the drive address depends on the condition of pin 28 of the AT interface cable. In the case when pin 28 is ground or low, the drive is a Master. If pin 28 is open or high level, the drive is a Slave.

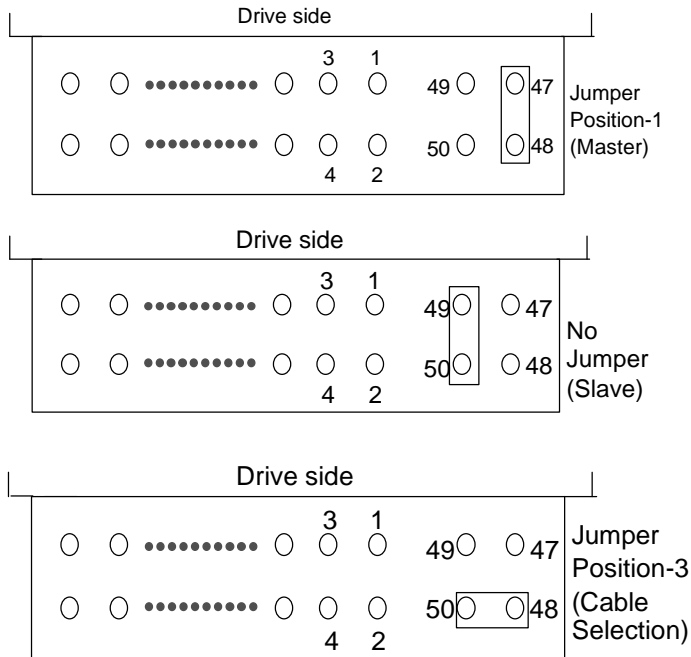

### Drive Address Setting by Jumper Cable

### Cabling

The maximum cable length from the host system to the HDD plus circuit pattern in the host system shall not exceed 18 inches.

### AT Signal Connector

The AT signal connector is designed to mate with Dupont part number 69764-044 or equivalent.

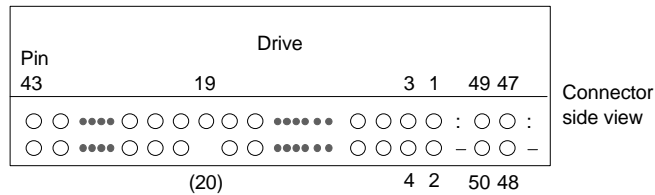

### 44 pin AT Connector

#### Notes:

1. Pin position 20 is left blank for secure connector insertion.
2. Pin position 47 through 50 are used for drive address setting.

### **Data Organization**

DBOA	-2720	-2540	-2528	-2360
Head Number	16	16	16	16
Sectors/Track	63	63	63	63
Cylinder Number	1400	1050	1024	700
Sector Size	512	512	512	512
Total Customer	1,411,200	1,058,400	1,032,192	705,600
Usable Data Sectors				
Total Customer	722MB	541MB	528MB	361MB
Reusable Data Bytes				

### **DC Power Requirements**

Supply Voltage	+5
Volts Power Supply Ripple (0-20 Mhz) (1)	100 mv p-p max
Tolerance (2)	+/-5%
<i>Supply Current</i>	<i>Pop. Mean</i>
Idle average (3)	0.19 A RMS
Read/Write	0.46 A RMS
Seek average (4)	0.46 A RMS
Standby	0.06 A RMS
Startup	0.94 A RMS
(maximum(peak) (5))	
Supply Rise Time	7-100 ms

#### *Notes:*

1. The maximum supply ripple is measured at 5V input of the HDD.
2. The disk drive shall not incur damage for an over voltage condition of +25% (maximum duration of 20ms) on the 5 volt nominal supply.
3. Idle current is specified at inner track.
4. The seek average current is specified based on three operations per 100.
5. The worst case operating current includes motor surge.

### **Signal Definition**

The pin assignments of interface signals are listed as follows:

PIN	Signal	I/O	PIN	Signal	I/O
01	-HRESET	I	02	GND	
03	HD07	I/O	04	HD08	I/O
05	HD06	I/O	06	HD09	I/O
07	HD05	I/O	08	HD10	I/O
09	HD04	I/O	10	HD11	I/O
11	HD03	I/O	12	HD12	I/O
13	HD02	I/O	14	HD13	I/O

15	HD01	I/O	16	HD14	I/O
17	HD00	I/O	18	HD15	I/O
19	GND		(20)	Key	
21	DMARQ		22	GND	
23	-HIOW	I	24	GND	
25	-HIOR	I	26	GND	
27	IORDY	O	28	CSEL	I
29	DMACK		30	GND	
31	HIRQ	O	32	-HIOCS16	O
33	HA01	I	34	-PDIAG	I/O
35	HA00	I	36	HA02	I
37	-HCSO	I	38	-HCS1	I
39	-DASP	I/O	40	GND	
41	+5V Logic PWR		42	+5V Motor PWR	
43	GND		44	(Resv)	

*Note:*

"O" designates an output from the Drive.

"I" designates an input to the Drive.

"I/O" designates an input/output common.

"PWR" designates a power supply to the Drive.

"(Resv)" designates reserved pins which must be left unconnected.

*Note:*

There are two input pins for +5 V power supply, "+5V LOGIC" and "+5V MOTOR". "+5V LOGIC" is connected to the internal logic circuits and "+5V MOTOR" is connected to the spindle motor and motor driver.

It is possible to turn on and off "+5V LOGIC" by an external switch circuit to reduce power consumption to the least possible. In this mode, a voltage drop out due to the motor spin up current can be reduced by connecting "+5V MOTOR" line into the system power source directly. If the above power management option is used, all signal lines that will be electrically active in the host system while the HDD is disconnected from power line, shall be isolated by Three-State line drivers. Internal leakage through ESD protection circuit may pull down LPUL (Least Positive Up Level) of logic signal below the specification.

Use both lines in parallel, for regular HDD applications.

***Command Description***

The following Commands are supported by the Drive:

Commands	(HEX)
Check Power Mode	(E5)
Check Power Mode*	(98)
Disable Password	(F6)
Execute Drive Diagnostics	(90)
Erase Prepare	(F3)
Erase Unit	(F4)

Format Track	(50)
Freeze Lock	(F5)
Identify Drive	(EC)
Idle	(E3)
Idle*	(97)
Idle Immediate	(E1)
Idle Immediate*	(95)
Initialize Drive Parameters	(91)
Read Buffer	(E4)
Read DMA (retry)	(C8)
Read DMA (no retry)	(C9)
Read Long (retry)	(22)
Read Long (no retry)	(23)
Read Multiple	(C4)
Read Sectors (retry)	(20)
Read Sectors (no retry)	(21)
Read Verify Sectors (retry)	(40)
Read Verify Sectors (no retry)	(41)
Recalibrate	(1X)
Seek	(7X)
Set Features	(EF)
Set Multiple	(C6)
Set Password	(F1)
Sleep	(E6)
Sleep*	(99)
Standby	(E2)
Standby*	(96)
Standby Immediate	(EO)
Standby Immediate*	(94)
Unlock	(F2)
Write Buffer	(E8)
Write DMA (retry)	(CA)
Write DMA (no retry)	(CB)
Write Long (retry)	(32)
Write Long (no retry)	(33)
Write Multiple	(C5)
Write Sectors (retry)	(30)
Write Sectors (no retry)	(31)
Write Verify	(3C)

## ***Operating Modes***

### *Description*

#### *Spin-Up*

Start up time period from spindle stop or power down.

### *Seek*

Seek operation mode.

### *Write*

Write operation mode.

### *Read*

Read operation mode.

### *Idle*

Spindle motor and Servo system are working normally. Other modules except the servo control and Host Interface are sleeping. Commands can be received and processed immediately.

### *Standby*

Spindle motor is stopped. All modules except Interface are sleeping. Commands can be received immediately. HDD is an interrupt waiting mode with the lowest power dissipation.

### **Notes:**

1. Upon power down or Spindle stopped, a head locking mechanism will secure the heads in the ID parking position.
2. Sleep command is handled like the Standby command. Recovering from standby mode does not need soft reset nor hard reset.

### ***Electromagnetic Compatibility***

The Drive meets the following EMC requirements when installed in the user system and exercised with a random accessing routine at maximum data rate:

United States Federal Communication Commission (FCC) Rules and Regulations Part 15, Subject J - Computer Devices "Class B Limits".

European Economic Community (EEC) directive #76/889 related to the control of radio frequency interference and the Verband Deutscher Elektrotechniker (VDE) requirements of Germany (GOP).

### ***Operating Environment***

#### *Humidity:*

Operating Relative Humidity: 8% to 90% non-condensing

Non-Operating Relative Humidity: 5% to 95% non-condensing

#### *Wet Bulb Temperature:*

Maximum Wet Bulb: Operating 29.4 degrees C non-condensing

Non-Operating 40 degrees C non-condensing

#### *Elevation:*

Operating Altitude: -300 to 3000m

Ship/Storage: -300 to 12000m

Altitude

*Temperature:*

Operating	5 to 55 degrees C*
Storage	0 to 65 degrees C
Shipping	-40 to 65 degrees C
Temperature Gradient (Operating, Storage & Shipping)	20 degrees C per hour (maximum)

*\* Note:*

The system is responsible for providing sufficient air movement to maintain surface temperature below 60 deg C at the center of top cover of the drive.

*Air Cooling Requirement*

The host system must provide sufficient air flow across the drive to maintain the temperature at less than 60 degrees C (measured at the center of the drive's top cover).

*Operating Shock*

The Drive will withstand (with no hard error) a 100G half-sine wave shock pulse of 2ms duration.

*Non-Operating Shock*

The Drive will withstand (with no permanent damage or degradation in performance) a 120G half-sine wave shock pulse of 11ms duration or 500G for 2ms.

*Operating and Non-Operating Vibration*

Due to the complexity of this subject we recommend that users contact the Distributor to discuss how to perform the necessary measurements if they believe this to be an area which requires evaluation.

**Caution of Usage**

DO NOT PRESS on the CENTER of the drive.

- \* Do not press when you take out the drive.
- \* Do not press when you carry the drive.
- \* Attach the drive free from pressing force.

***Mechanical Data***

Dimensions	DBOA-2720/2540/2528/2360
Height(mm)	12.5
Width(mm)	69.85
Length(mm)	100.2
Weight(gram)	140 Max

***Mounting Orientation:***

The drive will operate in all axes (6 directions). The drive will operate within the specified error rates when tilted  $\pm 5$  degrees from these positions.

Performance and error rate will stay within specification limits if the drive is operated in the other permissible orientations from which it was formatted. Thus a drive formatted in a horizontal orientation will be able to run vertically and vice versa.

The recommended mounting screw torque is  $3 \pm 0.5$  kgf. cm.

The recommended mounting screw depth is  $3.0 \pm 0.3$  mm for bottom and  $3.5 \pm 0.5$  mm for horizontal mounting.

The drive must be securely mounted in the system to prevent motion or vibration during a seek operation or spindle rotation using appropriate screws or equivalent mounting hardware.

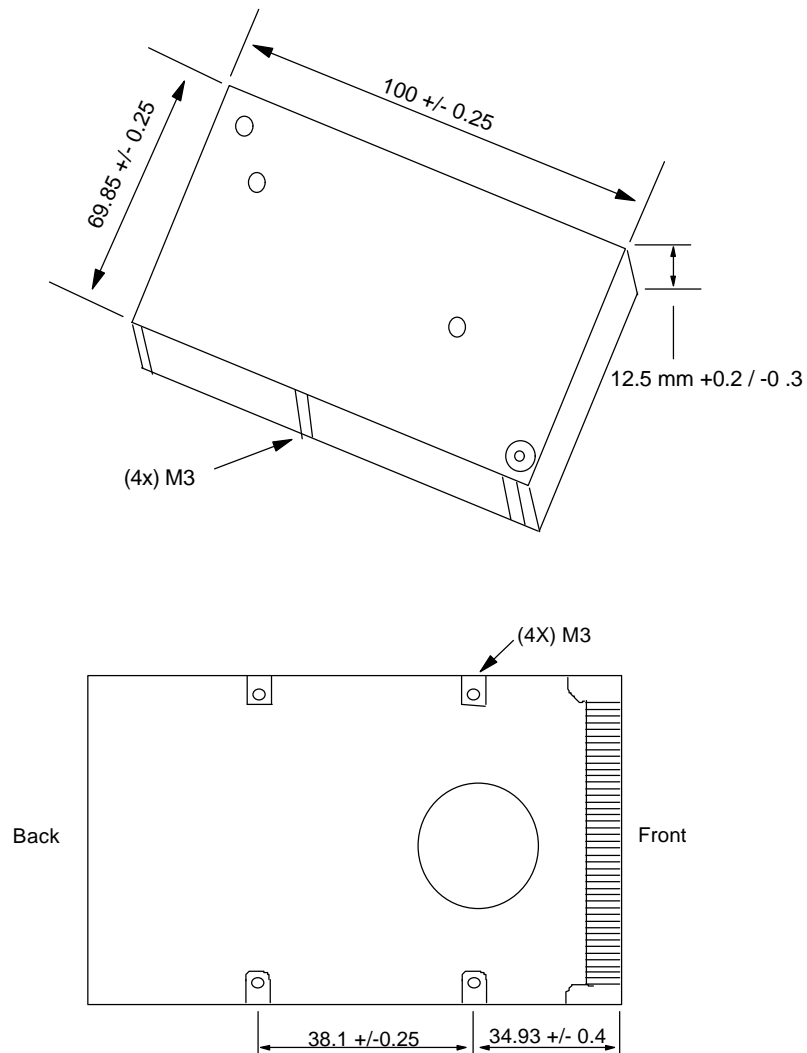

Vibration and shock tests are to be conducted with the drive mounted to the equipment using the bottom four screw holes.

The maximum allowable penetration of the mounting screw is 3.5mm.

**WARNING:** This disk drive can be damaged by Electro-Static Discharge; please follow recommended ESD procedures before unpacking or handling the drive. Ask your Dealer for details if you need assistance.

**PACKAGING:** The drive must be protected against Electro-Static Discharge especially when being handled. The safest way to avoid damage is to put the drive in an anti-static bag before ESD wrist straps etc, are removed.

Drives should only be shipped in approved containers; severe damage can be caused to the drive if the packaging does not adequately protect against the shock levels induced when a box is dropped. Consult your IBM marketing representative if you do not have an approved shipping container.

AMP is a trademark of AMP Incorporated.

Molex is a trademark of Molex Incorporated.

DATA MATE is a trademark of AMP Incorporated.

Western Digital is a trademark of the Western Digital Corporation.

NEXT is a trademark of NEXT Corporation.

This data sheet is not a substitute for the full product specification, which should be used when detailed information is required.

Product Description data represents IBM's design objectives and is provided for comparative purposes; actual results may vary based on a variety of factors. This product data does not constitute a warranty. Questions regarding IBM's warranty terms or methodology used to derive this data should be referred to your IBM OEM representative. Data subject to change without notice.