

# Hitachi Global Storage Technologies

Hard disk drive specifications

## Travelstar 60GH & 40GN

2.5 inch ATA/IDE

Models: IC25T060ATCS05  
IC25N040ATCS04  
IC25N030ATCS04  
IC25N020ATCS04  
IC25N010ATCS04



Revision 3.0

13 January 2003

---

# Hitachi Global Storage Technologies

Hard disk drive specifications

## **Hitachi Travelstar 60GH & 40G $\Gamma$**

2.5 inch ATA/IDE

Models: IC25T060ATCS05  
IC25N040ATCS04  
IC25N030ATCS04  
IC25N020ATCS04  
IC25N010ATCS04



Revision 3.0

13 January 2003

---

**1st Edition (Revision 0.1) S07N-7681-00 (19 September 2001) Preliminary**  
**2nd Edition (Revision 0.2) S07N-7681-01 (23 October 2001) Preliminary**  
**3rd Edition (Revision 0.3) S07N-7681-02 (25 October 2001) Preliminary**  
**4th Edition (Revision 0.4) S07N-7681-03 (29 October 2001) Preliminary**  
**5th Edition (Revision 0.5) S07N-7681-04 (1 November 2001) Preliminary**  
**6th Edition (Revision 0.6) S07N-7681-05 (2 November 2001) Preliminary**  
**7th Edition (Revision 0.7) S07N-7681-06 (5 November 2001) Preliminary**  
**8th Edition (Revision 1.0) S07N-7681-07 (16 November 2001)**  
**9th Edition (Revision 2.0) S07N-7681-08 (4 December 2001)**  
**10th Edition (Revision 3.0) S07N-7681-09 (22 January 2002)**

**The following paragraph does not apply to the United Kingdom or any country where such provisions are inconsistent with local law:** HITACHI GLOBAL STORAGE TECHNOLOGIES PROVIDES THIS PUBLICATION “AS IS” WITHOUT WARRANTY OF ANY KIND, EITHER EXPRESS OR IMPLIED, INCLUDING, BUT NOT LIMITED TO, THE IMPLIED WARRANTIES OF MERCHANTABILITY OR FITNESS FOR A PARTICULAR PURPOSE. Some states do not allow disclaimer or express or implied warranties in certain transactions, therefore, this statement may not apply to you.

This publication could include technical inaccuracies or typographical errors. Changes are periodically made to the information herein; these changes will be incorporated in new editions of the publication. Hitachi may make improvements or changes in any products or programs described in this publication at any time.

It is possible that this publication may contain reference to, or information about, Hitachi products (machines and programs), programming, or services that are not announced in your country. Such references or information must not be construed to mean that Hitachi intends to announce such Hitachi products, programming, or services in your country.

Technical information about this product is available by contacting your local Hitachi Global Storage Technologies representative or on the Internet at <http://www.hgst.com>

Hitachi Global Storage Technologies may have patents or pending patent applications covering subject matter in this document. The furnishing of this document does not give you any license to these patents.

**©Copyright Hitachi Global Storage Technologies**

Note to U.S. Government Users —Documentation related to restricted rights —Use, duplication or disclosure is subject to restrictions set forth in GSA ADP Schedule Contract with Hitachi Global Storage Technologies.

---

# Table of contents

|   |     |
|---|-----|
| <b>Figures</b> .....                              | vii |
| <b>1.0 General</b> .....                          | 1   |
| 1.1 Abbreviations .....                           | 1   |
| 1.2 References .....                              | 3   |
| 1.3 General caution .....                         | 3   |
| 1.4 Drive handling precautions .....              | 3   |
| <b>2.0 General features</b> .....                 | 5   |
| <br>  |     |
| <b>Part 1. Functional specification</b> .....     | 7   |
| <br>  |     |
| <b>3.0 Fixed disk subsystem description</b> ..... | 9   |
| 3.1 Control Electronics .....                     | 9   |
| 3.2 Head disk assembly data .....                 | 9   |
| <b>4.0 Fixed disk characteristics</b> .....       | 11  |
| 4.1 Formatted capacity by model number .....      | 11  |
| 4.2 Data sheet .....                              | 12  |
| 4.3 Cylinder allocation by model number .....     | 12  |
| 4.4 Performance characteristics .....             | 14  |
| 4.4.1 Command overhead .....                      | 14  |
| 4.4.2 Mechanical positioning .....                | 15  |
| 4.4.3 Operating modes .....                       | 17  |
| <b>5.0 Data integrity</b> .....                   | 19  |
| 5.1 Data loss on power off .....                  | 19  |
| 5.2 Write Cache .....                             | 19  |
| 5.3 Equipment status .....                        | 19  |
| 5.4 WRITE safety .....                            | 20  |
| 5.5 Data buffer test .....                        | 20  |
| 5.6 Error recovery .....                          | 20  |
| 5.7 Automatic reallocation .....                  | 20  |
| 5.7.1 Nonrecovered write errors .....             | 20  |
| 5.7.2 Nonrecoverable read error .....             | 20  |
| 5.7.3 Recovered read errors .....                 | 20  |
| 5.8 ECC .....                                     | 21  |
| <b>6.0 Specification</b> .....                    | 23  |
| 6.1 Environment .....                             | 23  |
| 6.1.1 Temperature and humidity .....              | 23  |
| 6.1.2 Radiation noise .....                       | 24  |
| 6.1.3 Conductive noise .....                      | 24  |
| 6.1.4 Magnetic fields .....                       | 24  |
| 6.2 DC power requirements .....                   | 25  |
| 6.2.1 Power consumption efficiency .....          | 26  |
| 6.3 Start up Current .....                        | 26  |
| 6.4 Reliability .....                             | 28  |
| 6.4.1 Data reliability .....                      | 28  |
| 6.4.2 Failure prediction (S.M.A.R.T.) .....       | 28  |
| 6.4.3 Cable noise interference .....              | 28  |
| 6.4.4 Service life and usage condition .....      | 28  |

|  |               |
|--|---------------|
| 6.4.5 Preventive maintenance                   | 29            |
| 6.4.6 Load/unload                              | 29            |
| 6.5 Mechanical specifications                  | 31            |
| 6.5.1 Physical dimensions and weight           | 31            |
| 6.5.2 Mounting hole locations                  | 31            |
| 6.5.3 Connector and jumper description         | 32            |
| 6.5.4 Mounting orientation                     | 32            |
| 6.5.5 Load/unload mechanism                    | 33            |
| 6.6 Vibration and shock                        | 34            |
| 6.6.1 Operating vibration                      | 34            |
| 6.6.2 Nonoperating vibration                   | 35            |
| 6.6.3 Operating shock                          | 35            |
| 6.6.4 Nonoperating shock                       | 36            |
| 6.7 Acoustics                                  | 37            |
| 6.7.1 Sound power level                        | 37            |
| 6.7.2 Discrete tone penalty                    | 38            |
| 6.8 Identification labels                      | 39            |
| 6.9 Electromagnetic compatibility              | 39            |
| 6.9.1 CE Mark                                  | 39            |
| 6.9.2 C-Tick Mark                              | 39            |
| 6.10 Safety                                    | 40            |
| 6.10.1 UL and CSA approval                     | 40            |
| 6.10.2 IEC compliance                          | 40            |
| 6.10.3 German Safety Mark                      | 40            |
| 6.10.4 Flammability                            | 40            |
| 6.10.5 Secondary circuit protection            | 40            |
| 6.11 Packaging                                 | 40            |
| <b>7.0 Electrical interface specifications</b> | <b>41</b>     |
| 7.1 Cabling                                    | 41            |
| 7.2 Interface connector                        | 41            |
| 7.3 Signal definitions                         | 42            |
| 7.4 Signal descriptions                        | 44            |
| 7.5 Interface logic signal levels              | 47            |
| 7.6 Reset timings                              | 47            |
| 7.7 PIO timings                                | 48            |
| 7.8 Multiword DMA timings                      | 49            |
| 7.9 Ultra DMA timings                          | 50            |
| 7.9.1 Initiating Read DMA                      | 50            |
| 7.9.2 Host Pausing Read DMA                    | 51            |
| 7.9.3 Host Terminating Read DMA                | 52            |
| 7.9.4 Device Terminating Read DMA              | 53            |
| 7.9.5 Initiating Write DMA                     | 54            |
| 7.9.6 Device Pausing Write DMA                 | 55            |
| 7.9.7 Device Terminating Write DMA             | 56            |
| 7.9.8 Host Terminating Write DMA               | 57            |
| 7.10 Drive address setting                     | 58            |
| 7.10.1 Drive default address setting           | 58            |
| 7.11 Addressing of HDD registers               | 59            |
| <br><b>Part 2. Interface specification</b>     | <br><b>61</b> |
| <br><b>8.0 General</b>                         | <br><b>63</b> |
| 8.1 Introduction                               | 63            |

|   |           |
|---|-----------|
| 8.2 Terminology .....   | 63        |
| <b>9.0 Deviations from standard .....</b>                     | <b>65</b> |
| <b>10.0 Registers .....</b>                                   | <b>67</b> |
| 10.1 Alternate Status Register .....                          | 68        |
| 10.2 Command Register .....                                   | 68        |
| 10.3 Cylinder High Register .....                             | 68        |
| 10.4 Cylinder Low Register .....                              | 68        |
| 10.5 Data Register .....                                      | 69        |
| 10.6 Device Control Register .....                            | 69        |
| 10.7 Drive Address Register .....                             | 70        |
| 10.8 Device/Head Register .....                               | 70        |
| 10.9 Error Register .....                                     | 71        |
| 10.10 Features Register .....                                 | 71        |
| 10.11 Sector Count Register .....                             | 71        |
| 10.12 Sector Number Register .....                            | 72        |
| 10.13 Status Register .....                                   | 72        |
| <b>11.0 General operation descriptions .....</b>              | <b>73</b> |
| 11.1 Reset response .....                                     | 73        |
| 11.2 Register initialization .....                            | 75        |
| 11.3 Diagnostic and Reset considerations .....                | 76        |
| 11.4 Power-off considerations .....                           | 77        |
| 11.4.1 Load/Unload .....                                      | 77        |
| 11.4.2 Emergency unload .....                                 | 77        |
| 11.4.3 Required power-off sequence .....                      | 78        |
| 11.5 Sector Addressing Mode .....                             | 78        |
| 11.5.1 Logical CHS addressing mode .....                      | 78        |
| 11.5.2 LBA addressing mode .....                              | 79        |
| 11.6 Power management features .....                          | 80        |
| 11.6.1 Power Mode .....                                       | 80        |
| 11.6.2 Power management commands .....                        | 80        |
| 11.6.3 Standby/Sleep command completion timing .....          | 80        |
| 11.6.4 Standby timer .....                                    | 81        |
| 11.6.5 Status .....   | 81        |
| 11.6.6 Interface Capability for Power Modes .....             | 81        |
| 11.6.7 Initial Power Mode at Power On .....                   | 81        |
| 11.7 Advanced Power Management (ABLE-3) feature .....         | 82        |
| 11.7.1 Performance Idle Mode .....                            | 82        |
| 11.7.2 Active Idle Mode .....                                 | 82        |
| 11.7.3 Low Power Idle Mode .....                              | 82        |
| 11.7.4 Transition Time .....                                  | 82        |
| 11.8 S.M.A.R.T. Function .....                                | 84        |
| 11.8.1 Attributes .....                                       | 84        |
| 11.8.2 Attribute values .....                                 | 84        |
| 11.8.3 Attribute thresholds .....                             | 84        |
| 11.8.4 Threshold exceeded condition .....                     | 84        |
| 11.8.5 S.M.A.R.T. commands .....                              | 84        |
| 11.8.6 S.M.A.R.T. operation with power management modes ..... | 85        |
| 11.9 Security Mode Feature Set .....                          | 86        |
| 11.9.1 Security Mode .....                                    | 86        |
| 11.9.2 Security level .....                                   | 86        |
| 11.9.3 Password .....   | 86        |
| 11.9.4 Master Password Revision Code .....                    | 87        |
| 11.9.5 Operation example .....                                | 87        |
| 11.9.6 Command table .....                                    | 90        |

|  |            |
|--|------------|
| 11.10 Protected Area Function                            | 92         |
| 11.10.1 Example for operation (In LBA Mode)              | 92         |
| 11.10.2 Set Max security extension commands              | 93         |
| 11.11 Address Offset Feature (vendor specific)           | 95         |
| 11.11.1 Enable/Disable Address Offset Mode               | 95         |
| 11.11.2 Identify Device Data                             | 96         |
| 11.11.3 Exceptions in Address Offset Mode                | 96         |
| 11.12 Seek Overlap                                       | 97         |
| 11.13 Write Cache function                               | 98         |
| 11.14 Delayed Write function (vendor specific)           | 98         |
| 11.14.1 Enable/Disable Delayed Write command             | 98         |
| 11.15 Reassign Function                                  | 99         |
| 11.15.1 Auto Reassign Function                           | 99         |
| <b>12.0 Command protocol</b>                             | <b>101</b> |
| 12.1 Data In commands                                    | 101        |
| 12.2 Data Out commands                                   | 103        |
| 12.3 Nondata commands                                    | 105        |
| 12.4 DMA Data Transfer commands                          | 106        |
| <b>13.0 Command descriptions</b>                         | <b>107</b> |
| 13.1 Check Power Mode (E5h/98h)                          | 111        |
| 13.2 Device Configuration Overlay (B1h)                  | 112        |
| 13.2.1 DEVICE CONFIGURATION RESTORE (subcommand C0h)     | 112        |
| 13.2.2 DEVICE CONFIGURATION FREEZE LOCK (subcommand C1h) | 113        |
| 13.2.3 DEVICE CONFIGURATION IDENTIFY (subcommand C2h)    | 113        |
| 13.2.4 DEVICE CONFIGURATION SET (subcommand C3h)         | 113        |
| 13.3 Enable/Disable Delayed Write (FAh: vendor specific) | 116        |
| 13.4 Execute Device Diagnostic (90h)                     | 117        |
| 13.5 Flush Cache (E7h)                                   | 118        |
| 13.6 Format Track (50h: vendor specific)                 | 119        |
| 13.7 Format Unit (F7h: vendor specific)                  | 120        |
| 13.8 Identify Device (ECh)                               | 122        |
| 13.9 Idle (E3h/97h)                                      | 131        |
| 13.10 Idle Immediate (E1h/95h)                           | 132        |
| 13.11 Initialize Device Parameters (91h)                 | 133        |
| 13.12 Read Buffer (E4h)                                  | 134        |
| 13.13 Read DMA (C8h/C9h)                                 | 135        |
| 13.14 Read Long (22h/23h)                                | 137        |
| 13.15 Read Multiple (C4h)                                | 139        |
| 13.16 Read Native Max ADDRESS (F8h)                      | 141        |
| 13.17 Read Sectors (20h/21h)                             | 143        |
| 13.18 Read Verify Sectors (40h/41h)                      | 145        |
| 13.19 Recalibrate (1xh)                                  | 147        |
| 13.20 Security Disable Password (F6h)                    | 148        |
| 13.21 Security Erase Prepare (F3h)                       | 149        |
| 13.22 Security Erase Unit (F4h)                          | 150        |
| 13.23 Security Freeze Lock (F5h)                         | 152        |
| 13.24 Security Set Password (F1h)                        | 153        |
| 13.25 Security Unlock (F2h)                              | 155        |
| 13.26 Seek (7xh)   | 157        |
| 13.27 Sense Condition (F0h: vendor specific)             | 158        |
| 13.28 Set Features (EFh)                                 | 159        |
| 13.29 Set Max ADDRESS (F9h)                              | 161        |
| 13.30 Set Multiple (C6h)                                 | 163        |
| 13.31 Sleep (E6h/99h)                                    | 164        |

|  |     |
|--|-----|
| 13.32 S.M.A.R.T. Function Set (B0h) .....                    | 165 |
| 13.32.1 S.M.A.R.T. Function Subcommands .....                | 166 |
| 13.32.2 Device Attributes Data Structure .....               | 170 |
| 13.32.3 Device Attribute Thresholds data structure .....     | 175 |
| 13.32.4 S.M.A.R.T. error log sector .....                    | 177 |
| 13.32.5 Self-test log data structure .....                   | 180 |
| 13.32.6 Error reporting .....                                | 181 |
| 13.33 Standby (E2h/96h) .....                                | 182 |
| 13.34 Standby Immediate (E0h/94h) .....                      | 183 |
| 13.35 Write Buffer (E8h) .....                               | 184 |
| 13.36 Write DMA (CAh/CBh) .....                              | 185 |
| 13.37 Write Long (32h/33h) .....                             | 187 |
| 13.38 Write Multiple (C5h) .....                             | 189 |
| 13.39 Write Sectors (30h/31h) .....                          | 191 |
| 13.40 Write Verify (3Ch: vendor specific) .....              | 193 |
| <b>14.0 Time-out values</b> .....                            | 195 |
| <b>15.0 Appendix</b> .....                                   | 197 |
| 15.1 Commands Support Coverage .....                         | 197 |
| 15.2 SET FEATURES Command Support Coverage .....             | 199 |
| 15.3 Changes from Hitachi Travelstar 48GH, 30GN & 15GN ..... | 200 |
| <b>Index</b> .....   | 201 |

This page intentionally left blank.

---

# Figures

|   |    |
|---|----|
| Figure 1. Handling Precaution 1   | 3  |
| Figure 2. Handling Precaution 2   | 3  |
| Figure 3. Formatted capacity by model number.                             | 11 |
| Figure 4. Data sheet  | 12 |
| Figure 5. Cylinder allocation of 60 GB model                              | 12 |
| Figure 6. Cylinder allocation — all models except 60 GB (high TPI format) | 13 |
| Figure 7. Cylinder allocation — all models except 60 GB (low TPI format)  | 13 |
| Figure 8. Performance characteristics                                     | 14 |
| Figure 9. Mechanical positioning performance                              | 15 |
| Figure 10. Full stroke seek time  | 15 |
| Figure 11. Single track seek time   | 16 |
| Figure 12. Latency time   | 16 |
| Figure 13. Drive ready time   | 16 |
| Figure 14. Operating mode   | 17 |
| Figure 15. Drive ready time   | 17 |
| Figure 16. Examples of error cases.                                       | 21 |
| Figure 17. Environmental condition  | 23 |
| Figure 18. Limits of temperature and humidity                             | 23 |
| Figure 19. Magnetic flux density limits                                   | 24 |
| Figure 20. DC Power requirements  | 25 |
| Figure 21. Power consumption efficiency                                   | 26 |
| Figure 22. Typical current wave form at start up of 60 GB model           | 26 |
| Figure 23. Typical current wave form at start up of 40 GB model           | 27 |
| Figure 24. Typical current wave form at start up of 20 GB model)          | 27 |
| Figure 25. Physical dimensions and weight                                 | 31 |
| Figure 26. Mounting hole locations of the 60 GB model.                    | 31 |
| Figure 27. Mounting hole locations of all models except 60 GB model.      | 32 |
| Figure 28. Random vibration PSD profile breakpoints (operating)           | 34 |
| Figure 29. Swept sine vibration   | 34 |
| Figure 30. Random Vibration PSD Profile Breakpoints (nonoperating)        | 35 |
| Figure 31. Operating shock  | 35 |
| Figure 32. Nonoperating shock   | 36 |
| Figure 33. Weighted sound power   | 37 |
| Figure 34. Interface connector pin assignments                            | 41 |
| Figure 35. Signal definition  | 42 |
| Figure 36. Special signal definitions for Ultra DMA                       | 43 |
| Figure 37. System reset timings   | 47 |
| Figure 38. PIO cycle timings  | 48 |
| Figure 39. Multiword DMA cycle timings                                    | 49 |
| Figure 40. Ultra DMA cycle timings (Initiating Read)                      | 50 |
| Figure 41. Ultra DMA cycle timings (Host Pausing Read)                    | 51 |
| Figure 42. Ultra DMA cycle timings (Host Terminating Read)                | 52 |
| Figure 43. Ultra DMA cycle timings (Device Terminating Read)              | 53 |
| Figure 44. Ultra DMA cycle timings (Initiating Write)                     | 54 |
| Figure 45. Ultra DMA cycle timings (Device Pausing Write)                 | 55 |
| Figure 46. Ultra DMA cycle timings (Device Terminating Write)             | 56 |
| Figure 47. Ultra DMA cycle timings (Host Terminating Write)               | 57 |
| Figure 48. Drive address setting  | 58 |
| Figure 49. I/O address map  | 59 |

|  |     |
|--|-----|
| Figure 50. Register Set  | 67  |
| Figure 51. Alternate Status Register                             | 68  |
| Figure 52. Device Control Register                               | 69  |
| Figure 53. Drive Address Register                                | 70  |
| Figure 54. Device/Head Register                                  | 70  |
| Figure 55. Error Register  | 71  |
| Figure 56. Status Register                                       | 72  |
| Figure 57. Reset response table                                  | 74  |
| Figure 58. Default Register Values                               | 75  |
| Figure 59. Diagnostic Codes                                      | 75  |
| Figure 60. Reset error register values                           | 76  |
| Figure 61. Device behavior by ATA commands.                      | 77  |
| Figure 62. Power conditions                                      | 81  |
| Figure 63. Initial setting                                       | 87  |
| Figure 64. Usual operation for POR                               | 88  |
| Figure 65. Password lost   | 89  |
| Figure 66. Command table for device lock operation (1 of 2)      | 90  |
| Figure 67. Command table for device lock operation (2 of 2)      | 91  |
| Figure 68. Set Max SET PASSWORD data content                     | 93  |
| Figure 69. Set Max security mode transition                      | 94  |
| Figure 70. Device address map before and after Set Feature       | 95  |
| Figure 71. Seek overlap  | 97  |
| Figure 72. Command set (1 of 2)                                  | 107 |
| Figure 73. Command set (2 of 2)                                  | 108 |
| Figure 74. Command Set (Subcommand)                              | 109 |
| Figure 75. Check Power Mode command (E5h/98h)                    | 111 |
| Figure 76. Check Power Mode Command (E5h/98h)                    | 112 |
| Figure 77. Device Configuration Overlay Features register values | 112 |
| Figure 78. Device Configuration Overlay Data structure           | 114 |
| Figure 79. DCO error information definition                      | 115 |
| Figure 80. Enable/Disable Delayed Write command (FAh)            | 116 |
| Figure 81. Execute Device Diagnostic command (90h)               | 117 |
| Figure 82. Flush Cache command (E7h)                             | 118 |
| Figure 83. Format Track command (50h)                            | 119 |
| Figure 84. Format Unit command (F7h)                             | 120 |
| Figure 85. Identify Device command (ECh)                         | 122 |
| Figure 86. Identify device information. (Part 1 of 7)            | 123 |
| Figure 87. Identify device information. (Part 2 of 7)            | 124 |
| Figure 88. Identify device information. (Part 3 of 7)            | 125 |
| Figure 89. Identify device information. (Part 4 of 7)            | 126 |
| Figure 90. Identify device information. (Part 5 of 7)            | 127 |
| Figure 91. Identify device information. (Part 6 of 7)            | 128 |
| Figure 92. Identify device information. (Part 7 of 7)            | 129 |
| Figure 93. Number of cylinders/heads/sectors by model.           | 130 |
| Figure 94. Idle command (E3h/97h)                                | 131 |
| Figure 95. Idle Immediate command (E1h/95h)                      | 132 |
| Figure 96. Initialize Device Parameters command (91h)            | 133 |
| Figure 97. Read Buffer command (E4h)                             | 134 |
| Figure 98. Read DMA command (C8h/C9h)                            | 135 |
| Figure 99. Read Long command (22h/23h)                           | 137 |
| Figure 100. Read Multiple command (C4h)                          | 139 |
| Figure 101. Read Native Max ADDRESS (F8h)                        | 141 |
| Figure 102. Read Sectors command (20h/21h)                       | 143 |
| Figure 103. Read Verify Sectors command (40h/41h)                | 145 |

|  |     |
|--|-----|
| Figure 104. Recalibrate command (1xh) .....                                  | 147 |
| Figure 105. Security Disable Password command (F6h) .....                    | 148 |
| Figure 106. Password Information for Security Disable Password command ..... | 148 |
| Figure 107. Security Erase Prepare command (F3h) .....                       | 149 |
| Figure 108. Security Erase Unit command (F4h) .....                          | 150 |
| Figure 109. Erase Unit information .....                                     | 150 |
| Figure 110. Security Freeze Lock command (F5h) .....                         | 152 |
| Figure 111. Security Set Password command (F1h) .....                        | 153 |
| Figure 112. Security Set Password information .....                          | 154 |
| Figure 113. Security Unlock command (F2h) .....                              | 155 |
| Figure 114. Security Unlock information .....                                | 156 |
| Figure 115. Seek command (7xh) .....   | 157 |
| Figure 116. Sense Condition Command (F0h) .....                              | 158 |
| Figure 117. Set Features command (EFh) .....                                 | 159 |
| Figure 118. Set Max ADDRESS (F9h) .....                                      | 161 |
| Figure 119. Set Multiple command (C6h) .....                                 | 163 |
| Figure 120. Sleep command (E6h/99h) .....                                    | 164 |
| Figure 121. S.M.A.R.T. Function Set command (B0h) .....                      | 165 |
| Figure 122. Log sector addresses .....                                       | 167 |
| Figure 123. Device Attribute Data Structure .....                            | 170 |
| Figure 124. Individual Attribute Data Structure .....                        | 171 |
| Figure 125. Status Flag definitions .....                                    | 172 |
| Figure 126. Device Attribute Thresholds Data Structure .....                 | 175 |
| Figure 127. Individual Threshold Data Structure .....                        | 176 |
| Figure 128. S.M.A.R.T. error log sector .....                                | 177 |
| Figure 129. Error log data structure .....                                   | 177 |
| Figure 130. Command data structure .....                                     | 178 |
| Figure 131. Error data structure .....                                       | 179 |
| Figure 132. Self-test log data structure .....                               | 180 |
| Figure 133. S.M.A.R.T. Error Codes .....                                     | 181 |
| Figure 134. Standby command (E2h/96h) .....                                  | 182 |
| Figure 135. Standby Immediate command (E0h/94h) .....                        | 183 |
| Figure 136. Write Buffer command (E8h) .....                                 | 184 |
| Figure 137. Write DMA command (CAh/CBh) .....                                | 185 |
| Figure 138. Write Long command (32h/33h) .....                               | 187 |
| Figure 139. Write Multiple command (C5h) .....                               | 189 |
| Figure 140. Write Sectors command (30h/31h) .....                            | 191 |
| Figure 141. Time-out values .....  | 195 |
| Figure 142. Command coverage (1 of 2) .....                                  | 197 |
| Figure 143. Command coverage (2 of 2) .....                                  | 198 |
| Figure 144. SET FEATURES command coverage .....                              | 199 |

This page intentionally left blank.

---

# 1.0 General

This document describes the specifications of the Hitachi Travelstar 60GH & 40GN, a 2.5-inch hard disk drive with ATA/IDE interface:

| Drive name      | Model Number   | Capacity (GB) | Height (mm) | Rotation speed (rpm) |
|-----------------|----------------|---------------|-------------|----------------------|
| Travelstar 60GH | IC25T060ATCS05 | 60            | 12.5        | 5,400                |
| Travelstar 40GN | IC25N040ATCS04 | 40            | 9.5         | 4,200                |
| Travelstar 40GN | IC25N030ATCS04 | 30            | 9.5         | 4,200                |
| Travelstar 40GN | IC25N020ATCS04 | 20            | 9.5         | 4,200                |
| Travelstar 40GN | IC25N010ATCS04 | 10            | 9.5         | 4,200                |

Part 1 of this document beginning on page 7 defines the hardware functional specification. Part 2 of this document beginning on page 61 defines the interface specification

*These specifications are subject to change without notice.*

---

## 1.1 Abbreviations

| <b>Abbreviation</b>     | <b>Meaning</b>                     |
|-------------------------|------------------------------------|
| <b>32 KB</b>            | 32 x 1024 bytes                    |
| <b>64 KB</b>            | 64 x 1024 bytes                    |
| <b>"</b>                | inch                               |
| <b>A</b>                | amp                                |
| <b>AC</b>               | alternating current                |
| <b>AT</b>               | Advanced Technology                |
| <b>ATA</b>              | Advanced Technology Attachment     |
| <b>Bels</b>             | unit of sound power                |
| <b>BIOS</b>             | Basic Input/Output System          |
| <b>°C</b>               | degrees Celsius                    |
| <b>CSA</b>              | Canadian Standards Association     |
| <b>C-UL</b>             | Canadian-Underwriters Laboratory   |
| <b>Cyl</b>              | cylinder                           |
| <b>DC</b>               | direct current                     |
| <b>DFT</b>              | Drive Fitness Test                 |
| <b>DMA</b>              | Direct Memory Access               |
| <b>ECC</b>              | error correction code              |
| <b>EEC</b>              | European Economic Community        |
| <b>EMC</b>              | electromagnetic compatibility      |
| <b>ERP</b>              | Error Recovery Procedure           |
| <b>ESD</b>              | electrostatic discharge            |
| <b>FCC</b>              | Federal Communications Commission  |
| <b>FRU</b>              | field replacement unit             |
| <b>G</b>                | gravity, a unit of force           |
| <b>Gb</b>               | 1 000 000 000 bits                 |
| <b>GB</b>               | 1 000 000 000 bytes                |
| <b>Gb/sq.in.</b>        | 1 000 000 000 bits per square inch |
| <b>G<sup>2</sup>/Hz</b> | (32 ft/sec) <sup>2</sup> per Hertz |
| <b>GND</b>              | ground                             |
| <b>h</b>                | hexadecimal                        |
| <b>HDD</b>              | hard disk drive                    |

|                              |   |
|------------------------------|---|
| <b>Hz</b>                    | hertz   |
| <b>I</b>                     | Input   |
| <b>ILS</b>                   | integrated lead suspension                          |
| <b>imped</b>                 | impedance   |
| <b>I/O</b>                   | Input/Output  |
| <b>ISO</b>                   | International Standards Organization                |
| <b>KB</b>                    | 1,000 bytes   |
| <b>Kbpi</b>                  | 1,000 Bit Per Inch                                  |
| <b>kgf-cm</b>                | kilogram (force)-centimeter                         |
| <b>KHz</b>                   | kilohertz   |
| <b>LBA</b>                   | logical block addressing                            |
| <b>Lw</b>                    | unit of A-weighted sound power                      |
| <b>m</b>                     | meter   |
| <b>max. or Max.</b>          | maximum   |
| <b>MB</b>                    | 1,000,000 bytes                                     |
| <b>Mbps</b>                  | 1,000,000 Bit per second                            |
| <b>Mb/sec</b>                | 1,000,000 Bit per second                            |
| <b>MB/sec</b>                | 1,000,000 bytes per second                          |
| <b>Mb/sq.in.</b>             | 1,000 ,00 bits per square inch                      |
| <b>MHz</b>                   | megahertz   |
| <b>MLC</b>                   | Machine Level Control                               |
| <b>mm</b>                    | millimeter  |
| <b>ms</b>                    | millisecond   |
| <b>us, <math>\mu</math>s</b> | microsecond   |
| <b>No. or #</b>              | number  |
| <b>oct/min</b>               | oscillations per minute                             |
| <b>O</b>                     | Output  |
| <b>OD</b>                    | Open Drain Programmed Input/Output                  |
| <b>PIO</b>                   |   |
| <b>POH</b>                   | power on hours                                      |
| <b>Pop.</b>                  | population  |
| <b>P/N</b>                   | part number   |
| <b>p-p</b>                   | peak-to-peak  |
| <b>PSD</b>                   | power spectral density                              |
| <b>RES</b>                   | radiated electromagnetic susceptibility             |
| <b>RFI</b>                   | radio frequency interference                        |
| <b>RH</b>                    | relative humidity                                   |
| <b>% RH</b>                  | per cent relative humidity                          |
| <b>RMS</b>                   | root mean square                                    |
| <b>RPM</b>                   | revolutions per minute                              |
| <b>RST</b>                   | reset   |
| <b>R/W</b>                   | read/write  |
| <b>sec</b>                   | second  |
| <b>Sect/Trk</b>              | sectors per track                                   |
| <b>SELV</b>                  | secondary low voltage                               |
| <b>S.M.A.R.T</b>             | Self-monitoring, analysis, and reporting technology |
| <b>TPI</b>                   | tracks per inch                                     |
| <b>Trk.</b>                  | track   |
| <b>TTL</b>                   | transistor-transistor logic                         |
| <b>UL</b>                    | Underwriters Laboratory                             |
| <b>V</b>                     | volt  |
| <b>VDE</b>                   | Verband Deutscher Electrotechniker                  |
| <b>W</b>                     | watt  |
| <b>3-state</b>               | transistor-transistor tristate logic                |

---

## 1.2 References

ATA/ATAPI-5 (T13/1321D Revision 3)

---

## 1.3 General caution

- Do not apply force to the top cover (See figure below).
  - Do not cover the breathing hole on the top cover (See figure below).
  - Do not touch the interface connector pins or the surface of the printed circuit board.
  - The drive can be damaged by shock or ESD (Electric Static Discharge). Any damages incurred to the drive after removing it from the shipping package and the ESD protective bag are the responsibility of the user
- 

## 1.4 Drive handling precautions

---

**Do not press!**

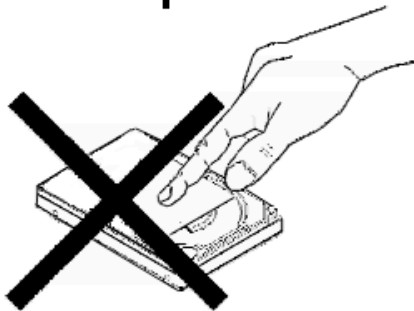

**Do not press on the drive cover during handling.**

---

Figure 1. Handling Precaution 1

---

**Do not cover this hole**

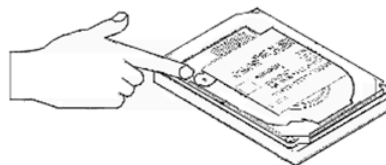

Covering this hole will result in loss of data

---

Figure 2. Handling Precaution 2

---

This page intentionally left blank.

---

## 2.0 General features

- 2.5-inch, 12.5- and 9.5-mm Height MCC Compliance
- Formatted capacities of 60 GB, 40 GB, 30 GB, 20 GB, and 10 GB
- 512 bytes/sector
- AT Interface (Enhanced IDE) conforming to ATA/ATAPI-5
- Integrated controller
- No-ID recording format
- Coding : 96/104 MTR
- Multi zone recording
- Enhanced ECC On-The-Fly
  - ◆ 40 bytes 3 way Interleaved Reed Solomon Code
  - ◆ 5 bytes per interleave On-The-Fly correction
- Segmented Buffer with write cache
  - ◆ 2 MB - Upper 280 KB is used for firmware
- Fast data transfer rate (up to 100 MB/s)
- Media data transfer rate (max):
  - ◆ 60-GB model - 261 Mb/s
  - ◆ all other models - 245 Mb/s
- Average seek time: 12 ms for read
- Closed-loop actuator servo (Embedded Sector Servo)
- Rotary voice coil motor actuator
- Load/Unload mechanism
- Mechanical latch
- Adaptive power save control
  - ◆ 60-GB model - 0.9 Watts at idle state
  - ◆ all other models - 0.65 Watts at idle state
- Power on to ready
  - ◆ 60-GB model - 5.0 sec
  - ◆ all other models - 3.0 sec
- Operating shock
  - ◆ 60-GB model - 150 G/2ms
  - ◆ all other models - 200 G/2ms
- Nonoperating shock
  - ◆ 60-GB model - 700 G/1ms
  - ◆ all other models - 800 G/1ms

This page intentionally left blank.

---

# Part 1. Functional specification

This page intentionally left blank.

---

## 3.0 Fixed disk subsystem description

---

### 3.1 Control Electronics

The control electronics works with the following functions:

- AT Interface Protocol
- Embedded Sector Servo
- No-ID (TM) formatting
- Multizone recording
- Code: 96/104 MTR
- ECC On-The-Fly
- Enhanced Adaptive Battery Life Extender

---

### 3.2 Head disk assembly data

The following technologies are used in the drive:

- Pico Slider
- Smooth glass disk
- GMR head
- Integrated lead suspension (ILS)
- Load/unload mechanism
- Mechanical latch

This page intentionally left blank.

## 4.0 Fixed disk characteristics

### 4.1 Formatted capacity by model number

| Description              | IC25T060ATCS05 | IC25N040ATCS04 | IC25N030ATCS04 |
|--------------------------|----------------|----------------|----------------|
| <b>Physical Layout</b>   |                |                |                |
| Bytes per Sector         | 512            | 512            | 512            |
| Sectors per Track        |                |                |                |
| low TPI format           | 307–556        | 360–672        | 360–672        |
| high TPI format          |                | 336–648        | 336–648        |
| Number of Heads          | 8              | 4              | 3              |
| Number of Disks          | 4              | 2              | 2              |
| <b>Logical Layout</b>    |                |                |                |
| Number of Heads          | 16             | 16             | 16             |
| Number of Sectors/ Track | 63             | 63             | 63             |
| Number of Cylinders      | 16,383         | 16,383         | 16,383         |
| Number of Sectors        | 117,210,240    | 78,140,160     | 58,605,120     |
| Total Logical Data Bytes | 60,011,642,880 | 40,007,761,920 | 30,005,821,440 |

| Description              | IC25N020ATCS04 | IC25N010ATCS04 |
|--------------------------|----------------|----------------|
| <b>Physical Layout</b>   |                |                |
| Bytes per Sector         | 512            | 512            |
| Sectors per Track        |                |                |
| low TPI format           | 360–672        | 360–672        |
| high TPI format          | 336–648        | 336–648        |
| Number of Heads          | 2              | 1              |
| Number of Disks          | 1              | 1              |
| <b>Logical Layout</b>    |                |                |
| Number of Heads          | 16             | 16             |
| Number of Sectors/ Track | 63             | 63             |
| Number of Cylinders      | 16,383         | 16,383         |
| Number of Sectors        | 39,070,080     | 19,640,880     |
| Total Logical Data Bytes | 20,003,880,960 | 10,056,130,560 |

Figure 3. Formatted capacity by model number.

## 4.2 Data sheet

|   | 60-GB model | All other models   |
|---|-------------|--------------------|
| Rotational Speed (RPM)                            | 5,400       | 4,200              |
| Data transfer rates (buffer to/from media) (Mbps) | 146–262     | 130–245<br>125–241 |
| Data transfer rates (Mbyte/sec)<br>ULTRA DMA 100  | 100         | 100                |
| Recording density (Kbpi) (Max)                    | 459         | 528<br>509         |
| Track density (Ktpi)                              | 60.4        | 63.5<br>66.4       |
| Areal density (Gb/sq.in.- Max)                    | 28          | 34                 |
| Number of zones                                   | 16          | 16                 |

Figure 4. Data sheet

## 4.3 Cylinder allocation by model number

| Zone | 60-GB model |                    |
|------|-------------|--------------------|
|      | Cylinder    | No. of Sectors/Trk |
| 0    | 0–1023      | 556                |
| 1    | 1024–2047   | 544                |
| 2    | 2048–4607   | 528                |
| 3    | 4608–6911   | 512                |
| 4    | 6912–9215   | 499                |
| 5    | 9216–13055  | 480                |
| 6    | 13056–15615 | 460                |
| 7    | 15616–17407 | 448                |
| 8    | 17408–20223 | 432                |
| 9    | 20224–22271 | 416                |
| 10   | 22272–24319 | 403                |
| 11   | 24320–27391 | 384                |
| 12   | 27392–29183 | 364                |
| 13   | 29184–30975 | 352                |
| 14   | 30976–33535 | 336                |
| 15   | 33536–35071 | 307                |

Figure 5. Cylinder allocation of 60 GB model

| <b>All other models - high TPI format</b> |                 |                           |
|---|-----------------|---------------------------|
| <b>Zone</b>                               | <b>Cylinder</b> | <b>No. of Sectors/Trk</b> |
| 0   | 0–511           | 648                       |
| 1   | 512–2559        | 640                       |
| 2   | 2560–4863       | 624                       |
| 3   | 4864–9215       | 600                       |
| 4   | 9216–11519      | 576                       |
| 5   | 11520–13823     | 560                       |
| 6   | 13824–16895     | 540                       |
| 7   | 16896–19967     | 520                       |
| 8   | 19968–21503     | 504                       |
| 9   | 21504–24831     | 480                       |
| 10  | 24832–27135     | 450                       |
| 11  | 27136–28671     | 440                       |
| 12  | 28672–31231     | 420                       |
| 13  | 31232–33791     | 400                       |
| 14  | 33792–37631     | 360                       |
| 15  | 37632–39935     | 336                       |

Figure 6. Cylinder allocation — all models except 60 GB (high TPI format)

| <b>All other models - low TPI format</b> |                 |                           |
|--|-----------------|---------------------------|
| <b>Zone</b>                              | <b>Cylinder</b> | <b>No. of Sectors/Trk</b> |
| 0  | 0–767           | 672                       |
| 1  | 768–3327        | 660                       |
| 2  | 3328–6655       | 640                       |
| 3  | 6656–8703       | 624                       |
| 4  | 8704–12287      | 600                       |
| 5  | 12288–15359     | 576                       |
| 6  | 15360–17151     | 560                       |
| 7  | 17152–19967     | 540                       |
| 8  | 19968–22015     | 520                       |
| 9  | 22016–23295     | 504                       |
| 10                                       | 23296–25343     | 480                       |
| 11                                       | 25344–26879     | 480                       |
| 12                                       | 26880–28159     | 450                       |
| 13                                       | 28160–31743     | 420                       |
| 14                                       | 31744–35327     | 384                       |
| 15                                       | 35328–38143     | 360                       |

Figure 7. Cylinder allocation — all models except 60 GB (low TPI format)

---

## 4.4 Performance characteristics

Drive performance is characterized by the following parameters:

- Command Overhead
- Mechanical Positioning
  - ◆ Seek Time
  - ◆ Latency
- Data Transfer Speed
- Buffering Operation (Look ahead/Write Cache)

*Note: All the above parameters contribute to drive performance. There are other parameters which contribute to the performance of the actual system. This specification defines the essential characteristics of the drive. This specification does not include the system throughput as this is dependent upon the system and the application.*

The following table gives a typical value for each parameter. The detailed descriptions are found in section 5.0.

---

| Function                              | 60-GB   | All other models   |
|---------------------------------------|---------|--------------------|
| Average Random Seek Time - Read (ms)  | 12      | 12                 |
| Average Random Seek Time - Write (ms) | 14      | 14                 |
| Rotational Speed (RPM)                | 5400    | 4200               |
| Power-on-to-ready (sec)               | 5.0     | 3.0                |
| Command overhead (ms)                 | 1.0     | 1.0                |
| Disk-buffer data transfer (Mb/s)      | 146-261 | 130-245<br>125-241 |
| Buffer-host data transfer (MB/s)      | 100     | 100                |

---

Figure 8. Performance characteristics

### 4.4.1 Command overhead

Command overhead time is defined as the interval from the time that a drive receives a command to the time that the actuator starts its motion.

## 4.4.2 Mechanical positioning

### 4.4.2.1 Average seek time (including settling)

---

| Command Type | Typical (ms) | Max. (ms) |
|--------------|--------------|-----------|
| Read         | 12           | 16        |
| Write        | 14           | 17        |

---

Figure 9. Mechanical positioning performance

Typical and Max. are defined throughout the performance specification as follows:

**Typical** Average of the drive population tested at nominal environmental and voltage conditions.

**Max.** Maximum value measured on any one drive over the full range of the environmental and voltage conditions. (See section 6.1, "Environment" on page 23 and section 6.2, "DC power requirements" on page 25)

The seek time is measured from the start of motion of the actuator to the start of a reliable read or write operation. A reliable read or write operation implies that error correction/recovery is not employed to correct arrival problems. The Average Seek Time is measured as the weighted average of all possible seek combinations.

$$\sum_{n=1}^{\text{max.}} (\text{max.} + 1 - n)(T_{n_{\text{in}}} + T_{n_{\text{out}}})$$

$$\text{Weighted Average} = \frac{\sum_{n=1}^{\text{max.}} (\text{max.} + 1 - n)(T_{n_{\text{in}}} + T_{n_{\text{out}}})}{(\text{max.} + 1)(\text{max.})}$$

Where: max. = maximum seek length

n = seek length (1-to-max.)

T<sub>n<sub>in</sub></sub> = inward measured seek time for an n-track seek

T<sub>n<sub>out</sub></sub> = outward measured seek time for an n-track seek

### 4.4.2.2 Full stroke seek

---

| Command Type | Typical (ms) | Max. (ms) |
|--------------|--------------|-----------|
| Read         | 23.0         | 30.0      |
| Write        | 24.0         | 31.0      |

---

Figure 10. Full stroke seek time

Full stroke seek time in milliseconds is the average time of 1000 full stroke seeks.

#### 4.4.2.3 Single track seek time (without command overhead, including settling)

| Command Type | Typical (ms) | Maximum (ms) |
|--------------|--------------|--------------|
| Read         | 2.5          | 4.0          |
| Write        | 3.0          | 4.5          |

Figure 11. Single track seek time

Single track seek is measured as the average of one (1) single track seek from every track in both directions (inward and outward).

#### 4.4.2.4 Average latency

| Model            | Rotational Speed (RPM) | Time for one revolution (ms) | Average Latency (ms) |
|------------------|------------------------|------------------------------|----------------------|
| 60-GB model      | 5400                   | 11.1                         | 5.5                  |
| All other models | 4200                   | 14.3                         | 7.1                  |

Figure 12. Latency time

#### 4.4.2.5 Drive ready time

| Condition         | Model            | Typical (sec) | Max. (sec) |
|-------------------|------------------|---------------|------------|
| Power On To Ready | 60-GB model      | 5.0           | 9.5        |
| Power On To Ready | All other models | 3.0           | 9.5        |

Figure 13. Drive ready time

**Ready** The condition in which the drive is able to perform a media access command (for example—read, write) immediately.

**Power On To Ready** This includes the time required for the internal self diagnostics.

### 4.4.3 Operating modes

| <b>Operating mode</b> | <b>Description</b>  |
|-----------------------|---|
| Spin-Up               | Start up time period from spindle stop or power down.   |
| Seek                  | Seek operation mode   |
| Write                 | Write operation mode  |
| Read                  | Read operation mode   |
| Performance           | The device is capable of responding immediately to idle media access requests. All electronic components remain powered and the full frequency servo remains operational.   |
| Active idle           | The device is capable of responding immediately to media access requests. Some circuitry—including servo system and R/W electronics—is in power saving mode. The head is parked near the mid-diameter the disk without servoing. A device in Active idle mode may take longer to complete the execution of a command because it must activate that circuitry. |
| Low power idle        | The head is unloaded onto the ramp position. The spindle motor is rotating at full speed.   |
| Standby               | The device interface is capable of accepting commands. The spindle motor is stopped. All circuitry but the host interface is in power saving mode. The execution of commands is delayed until the spindle becomes ready.  |
| Sleep                 | The device requires a soft reset or a hard reset to be activated. All electronics, including spindle motor and host interface, are shut off.  |

Figure 14. Operating mode

#### 4.4.3.1 Mode transition time

| <b>Model</b>        | <b>From</b> | <b>To</b> | <b>Transition Time (typ)</b> | <b>Transition Time (max.)</b> |
|---------------------|-------------|-----------|------------------------------|-------------------------------|
| 60-GB model         | Standby     | Idle      | 4.5                          | 9.5                           |
| 40-GB, 30-GB models | Standby     | Idle      | 2.0                          | 9.5                           |
| 20-GB, 10-GB models | Standby     | Idle      | 1.8                          | 9.5                           |

Figure 15. Drive ready time

#### 4.4.3.2 Operating mode at power on

The device goes into Idle mode after power on or hard reset as an initial state. Initial state may be changed to Standby mode using pin C on the interface connector. Refer to section 7.10 on page 58, "Drive address setting" for details.

#### 4.4.3.3 Adaptive power save control

The transient timing from Performance Idle mode to Active Idle mode and Active Idle mode to Low Power Idle mode is controlled adaptively according to the access pattern of the host system. The transient timing from Low Power Idle mode to Standby mode is also controlled adaptively, if it is allowed by Set Features Enable Advanced Power Management subcommand.

This page intentionally left blank.

---

## 5.0 Data integrity

---

### 5.1 Data loss on power off

- Data loss will not be caused by a power off during any operation except the write operation.
- A power off during a write operation causes the loss of any received or resident data that has not been written onto the disk media.
- A power off during a write operation might make a maximum of one sector of data unreadable. This state can be recovered by a rewrite operation.

---

### 5.2 Write Cache

When the write cache is enabled, the write command may complete before the actual disk write operation finishes. This means that a power off, even after the write command completion, could cause the loss of data that the drive has received but not yet written onto the disk.

In order to prevent this data loss, confirm the completion of the actual write operation prior to the power off by issuing a

- Soft reset
- Hard reset
- Flush Cache command
- Standby command
- Standby Immediate command
- Sleep command

Confirm the command's completion.

---

### 5.3 Equipment status

The equipment status is available to the host system any time the drive is not ready to read, write, or seek. This status normally exists at the power-on time and will be maintained until the following conditions are satisfied:

- The access recalibration/tuning is complete.
- The spindle speed meets the requirements for reliable operation.
- The self-check of the drive is complete.

The appropriate error status is made available to the host system if any of the following conditions occur after the drive has become ready:

- The spindle speed lies outside the requirements for reliable operation.
- The occurrence of a Write Fault condition.

---

## 5.4 WRITE safety

The drive ensures that the data is written into the disk media properly. The following conditions are monitored during a write operation. When one of these conditions exceeds the criteria, the write operation is terminated and the automatic retry sequence is invoked.

- Head off track
- External shock
- Low supply voltage
- Spindle speed out of tolerance
- Head open/short

---

## 5.5 Data buffer test

The data buffer is tested at power on reset and when a drive self-test is requested by the host. The test consists of a write/read '00'x and 'ff'x pattern on all buffers.

---

## 5.6 Error recovery

Errors occurring on the drive are handled by the error recovery procedure.

Errors that are uncorrectable after application of the error recovery procedure are reported to the host system as nonrecoverable errors.

---

## 5.7 Automatic reallocation

The sectors that show some errors may be reallocated automatically when specific conditions are met. The drive does not report any auto reallocation to the host system. The conditions for auto reallocation are described below.

### 5.7.1 Nonrecovered write errors

When a write operation cannot be completed after the Error Recovery Procedure (ERP) is fully carried out, the sectors are reallocated to the spare location. An error is reported to the host system only when the write cache is disabled and the auto reallocation has failed.

### 5.7.2 Nonrecoverable read error

When a read operation fails after ERP is fully carried out, a hard error is reported to the host system. This location is registered internally as a candidate for the reallocation. When a registered location is specified as a target of a write operation, a sequence of media verification is performed automatically. When the result of this verification meets the required criteria, this sector is reallocated.

### 5.7.3 Recovered read errors

When a read operation for a sector fails and is recovered at the specific ERP step, the sector is reallocated automatically. A media verification sequence may be run prior to the reallocation according to the predefined conditions.

## 5.8 ECC

The 40 byte three interleaved ECC processor provides user data verification and correction capability. The first 4 bytes of ECC are check bytes for user data and the other 36 bytes are Read Solomon ECC. Each interleave has 12 bytes for ECC. Hardware logic corrects up to 15 bytes (5 bytes for each interleave) errors on-the-fly.

Following are some examples of error cases. An "O" means that the byte contains no error. An "X" means that at least one bit of the byte is bad.

### On The Fly correctable

| Byte #        | 0 | 1 | 2 | 3 | 4 | 5 | 6 | 7 | 8 | 9 | 1 | 1 | 1 | 1 | 1 | 1 | 1 | Error byte # for each interleave |   |   |
|---------------|---|---|---|---|---|---|---|---|---|---|---|---|---|---|---|---|---|----------------------------------|---|---|
| Interleave    | A | B | C | A | B | C | A | B | C | A | B | C | A | B | C | A | B | C                                |   |   |
| Error pattern | X | X | X | X | X | X | X | X | X | X | X | X | X | X | O | O | O | 5                                | 5 | 5 |
| Error pattern | X | X | X | X | X | X | X | X | O | O | O | X | X | X | X | X | X | 5                                | 5 | 5 |

### Uncorrectable

| Byte #        | 0 | 1 | 2 | 3 | 4 | 5 | 6 | 7 | 8 | 9 | 1 | 1 | 1 | 1 | 1 | 1 | 1 | Error byte # for each interleave |   |   |
|---------------|---|---|---|---|---|---|---|---|---|---|---|---|---|---|---|---|---|----------------------------------|---|---|
| Interleave    | A | B | C | A | B | C | A | B | C | A | B | C | A | B | C | A | B | C                                |   |   |
| Error pattern | X | X | X | X | X | X | X | X | X | X | X | X | X | X | X | O | O | 6                                | 5 | 5 |
| Error pattern | X | O | O | X | O | O | X | O | O | X | O | O | X | O | O | X | O | 6                                | 0 | 0 |

Figure 16. Examples of error cases.

This page intentionally left blank.

# 6.0 Specification

## 6.1 Environment

### 6.1.1 Temperature and humidity

| Operating conditions         |                              |
|------------------------------|------------------------------|
| Temperature                  | 5 to 55°C (See note below)   |
| Relative humidity            | 8 to 90% noncondensing       |
| Maximum wet bulb temperature | 29.4°C noncondensing         |
| Maximum temperature gradient | 20°C/hour                    |
| Altitude                     | -300 to 3048 m (10,000 ft)   |
| Nonoperating conditions      |                              |
| Temperature                  | -40 to 65°C                  |
| Relative humidity            | 5 to 95% noncondensing       |
| Maximum wet bulb temperature | 40°C noncondensing           |
| Maximum temperature gradient | 20°C/hour                    |
| Altitude                     | -300 to 12,192 m (40,000 ft) |

Figure 17. Environmental condition

The system is responsible for providing sufficient air movement to maintain surface temperatures below 60°C at the center of top cover and below 63°C at the center of the drive circuit board assembly.

The maximum storage period in the shipping package is one year.

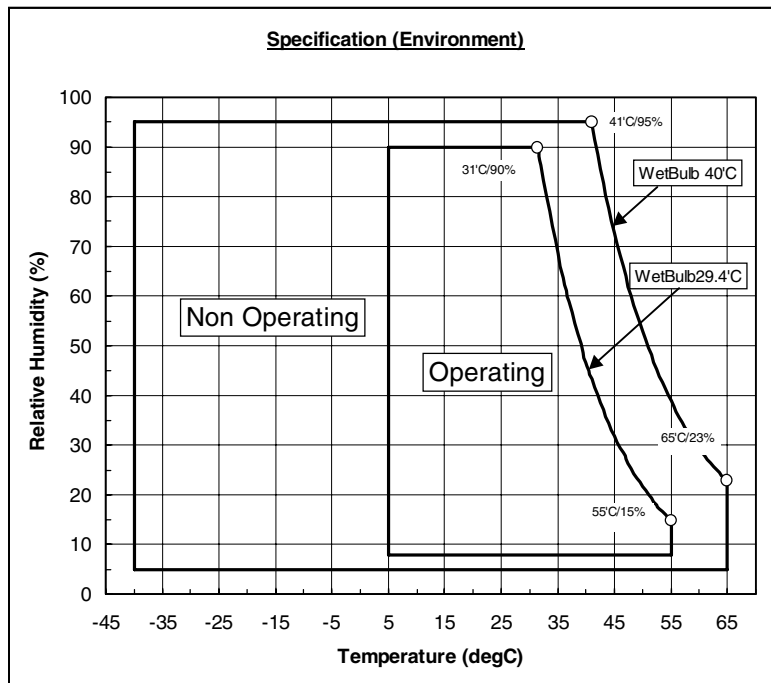

Figure 18. Limits of temperature and humidity

### 6.1.1.1 Corrosion test

The hard disk drive must be functional and show no signs of corrosion after being exposed to a temperature humidity stress of 50°C/90%RH (relative humidity) for one week followed by a temperature and humidity drop to 25°C/40%RH in 2 hours.

### 6.1.2 Radiation noise

The disk drive shall work without degradation of the soft error rate under the following magnetic flux density limits at the enclosure surface.

---

| Frequency (KHz) | Limits (Gauss RMS) |
|-----------------|--------------------|
| 0–60            | 5                  |
| 61–100          | 2.5                |
| 101–200         | 1                  |
| 201–400         | 0.5                |

---

Figure 19. Magnetic flux density limits

### 6.1.3 Conductive noise

The disk drive shall work without soft error degradation in the frequency range from DC to 20 Mhz injected through any two of the mounting screw holes of the drive when an AC current of up to 45 mA (p-p) is applied through a 50-ohm resistor connected to any two mounting screw holes.

### 6.1.4 Magnetic fields

The disk drive will withstand radiation and conductive noise within the limits shown below. The test method is defined in the Noise Susceptibility Test Method specification, P/N 95F3944.

## 6.2 DC power requirements

Connection to the product should be made in a safety extra low voltage (SELV) circuits. The voltage specifications are applied at the power connector of the drive.

| Item  | Requirements          |
|---|-----------------------|
| Nominal supply                              | +5 Volt dc            |
| Supply voltage                              | -0.3 Volt to 6.0 Volt |
| Power supply ripple (0–20 MHz) <sup>1</sup> | 100 mV p-p max.       |
| Tolerance <sup>2</sup>                      | ±5%                   |
| Supply rise time                            | 7–100 ms              |

| Watts (RMS Typical)                   | Models |             |             |
|---------------------------------------|--------|-------------|-------------|
|                                       | 60 GB  | 40GB, 30 GB | 20GB, 10 GB |
| Performance Idle average <sup>3</sup> | 2.0    | 1.85        | 1.85        |
| Active Idle average                   | 1.3    | 0.95        | 0.85        |
| Low Power Idle average                | 0.9    | 0.65        | 0.65        |
| Read average <sup>4</sup>             | 2.5    | 2.1         | 2.0         |
| Write average                         | 2.7    | 2.2         | 2.1         |
| Seek average <sup>5</sup>             | 2.6    | 2.3         | 2.3         |
| Standby                               | 0.25   | 0.25        | 0.25        |
| Sleep                                 | 0.1    | 0.1         | 0.1         |
| Startup (maximum peak) <sup>6</sup>   | 5.0    | 4.7         | 4.7         |
| Average from power on to ready        | 3.8    | 3.3         | 3.3         |

Footnotes:

<sup>1</sup> The maximum fixed disk ripple is measured at the 5 volt input of the drive.

<sup>2</sup> The disk drive shall not incur damage for an over voltage condition of +25% (maximum duration of 20 ms) on the 5 volt nominal supply.

<sup>3</sup> The idle current is specified at an inner track.

<sup>4</sup> The read/write current is specified based on three operations of 63 sector read/write per 100 ms.

<sup>5</sup> The seek average current is specified based on three operations per 100 ms.

<sup>6</sup> The worst case operating current includes motor surge.

Figure 20. DC Power requirements

## 6.2.1 Power consumption efficiency

| Capacity (GB)                           | 60    | 40    | 30    | 20    | 10    |
|---|-------|-------|-------|-------|-------|
| Power Consumption Efficiency (Watts/GB) | 0.015 | 0.016 | 0.022 | 0.033 | 0.065 |

Figure 21. Power consumption efficiency

*Note:* Power consumption efficiency is calculated as Power Consumption of Low Power Idle Watt/ Capacity (GB).

## 6.3 Start up Current

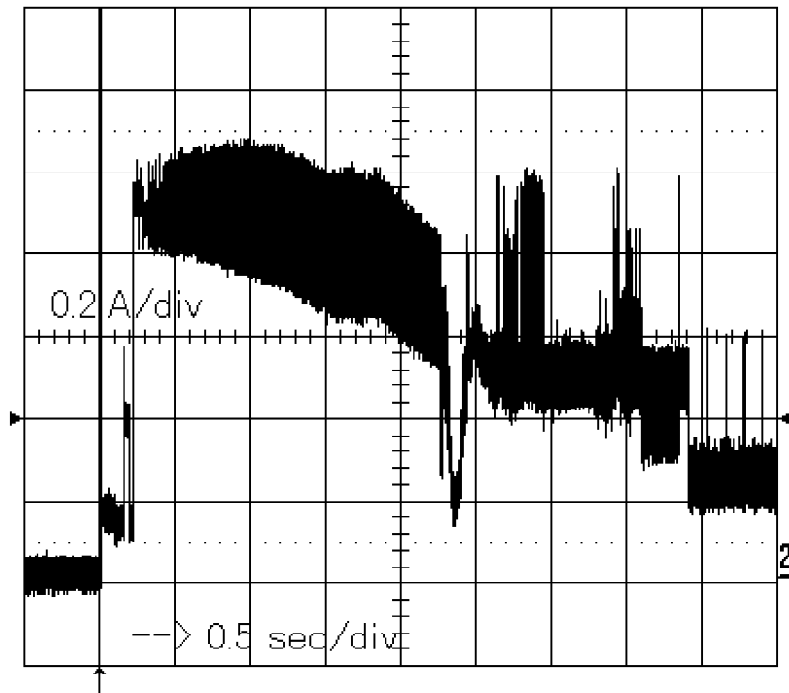

Figure 22. Typical current wave form at start up of 60 GB model

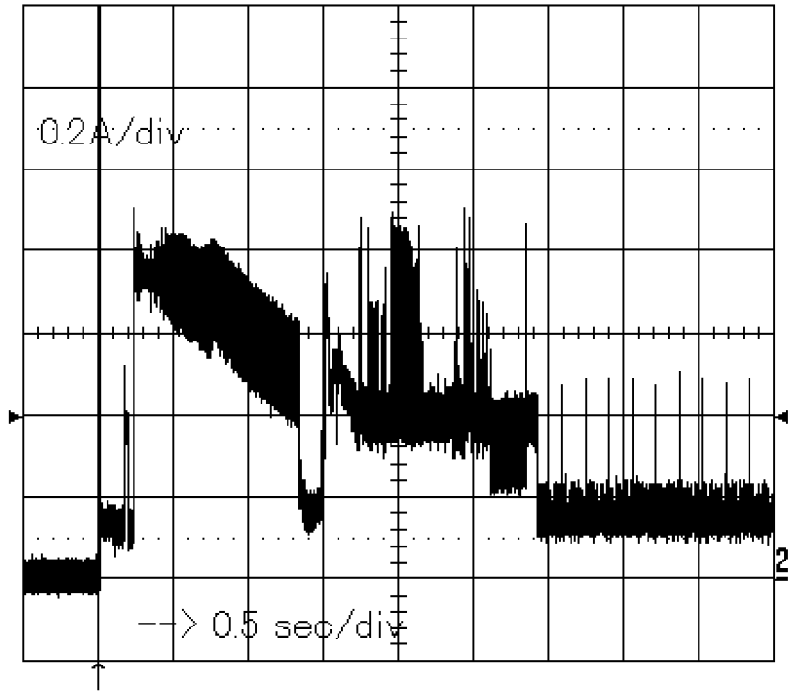

Figure 23. Typical current wave form at start up of 40 GB model

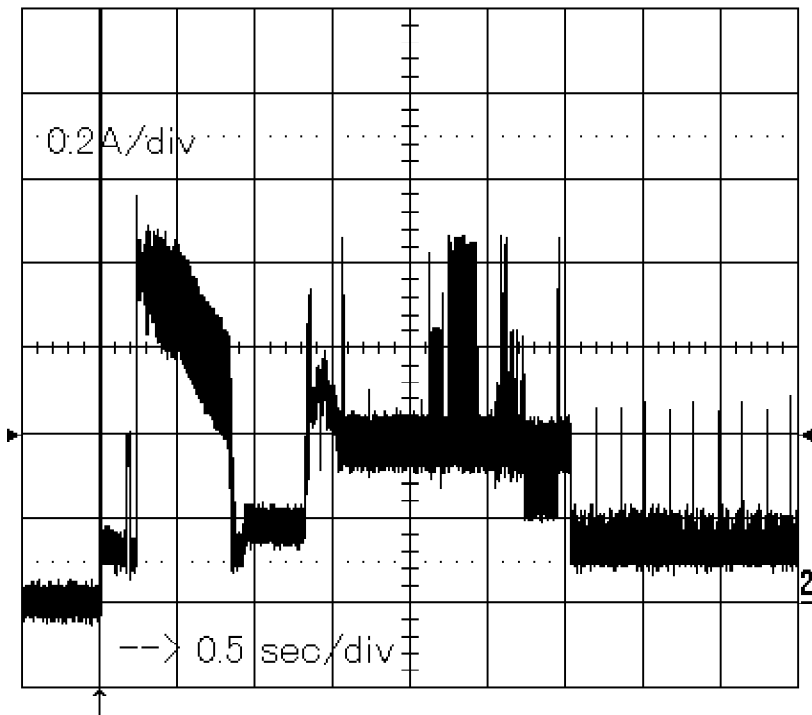

Figure 24. Typical current wave form at start up of 20 GB model)

---

## 6.4 Reliability

### 6.4.1 Data reliability

- Probability of not recovering data is 1 in  $10^{13}$  bits read
- ECC implementation

On-the-fly correction performed as a part of read channel function recovers up to 15 symbols of error in 1 sector (1 symbol is 8 bits).

### 6.4.2 Failure prediction (S.M.A.R.T.)

The drive supports Self-monitoring, analysis and reporting technology (S.M.A.R.T.) function. The details are described in section 11.8, "S.M.A.R.T. Function" on page 84 and 13.32, "S.M.A.R.T. Function Set (B0h)" on page 165.

### 6.4.3 Cable noise interference

To avoid any degradation of performance throughput or error when the interface cable is routed on top or comes in contact with the HDA assembly, the drive must be grounded electrically to the system frame by four screws. The common mode noise or voltage level difference between the system frame and power cable ground or AT interface cable ground should be in the allowable level specified in the power requirement section.

### 6.4.4 Service life and usage condition

The drive is designed to be used under the following conditions:

- The drive should be operated within specifications of shock, vibration, temperature, humidity, altitude, and magnetic field.
- The drive should be protected from ESD.
- The breathing hole in the top cover of the drive should not be covered.
- Force should not be applied to the cover of the drive.
- The specified power requirements of the drive should be satisfied.
- The drive frame should be grounded electrically to the system through four screws.
- The drive should be mounted with the recommended screw depth and torque.
- The interface physical and electrical requirements of the drive should satisfy ATA-5.
- The power-off sequence of the drive should comply with the 6.4.6.2, "Required power-off sequence."

Service life of the drive is approximately 5 years or 20,000 power on hours, whichever comes first, under the following assumptions:

- Less than 333 power on hours per month.
- Seeking/Writing/Reading operation is less than 20% of power on hours.

This does not represent any warranty or warranty period. Applicable warranty and warranty period are covered by the purchase agreement.

## 6.4.5 Preventive maintenance

None.

## 6.4.6 Load/unload

The product supports a minimum of 300,000 normal load/unloads.

Load/unload is a functional mechanism of the hard disk drive. It is controlled by the drive micro code. Specifically, unloading of the heads is invoked by the following commands:

- Hard reset
- Standby
- Standby immediate
- Sleep

Load/unload is also invoked as one of the idle modes of the drive.

The specified start/stop life of the product assumes that load/unload is operated normally, not in emergency mode.

### 6.4.6.1 Emergency unload

When hard disk drive power is interrupted while the heads are still loaded the micro code cannot operate and the normal 5-volt power is unavailable to unload the heads. In this case, normal unload is not possible. The heads are unloaded by routing the back EMF of the spinning motor to the voice coil. The actuator velocity is greater than the normal case and the unload process is inherently less controllable without a normal seek current profile.

Emergency unload is intended to be invoked in rare situations. Because this operation is inherently uncontrolled, it is more mechanically stressful than a normal unload.

The drive supports a minimum of 20,000 emergency unloads.

### 6.4.6.2 Required Power-Off Sequence

The required BIOS sequence for removing power from the drive is as follows:

- Step 1: Issue one of the following commands.
  - Standby
  - Standby immediate
  - Sleep

*Note: Do not use the Flush Cache command for the power off sequence because this command does not invoke Unload.*

- Step 2: Wait until the Command Complete status is returned.

In a typical case 350 ms are required for the command to finish completion; however, the BIOS time out value needs to be 30 seconds considering error recovery time. Refer to section 14.0, "Time-out values," on page 195.

- Step 3: Terminate power to HDD.

This power-down sequence should be followed for entry into any system power-down state, system suspend state, or system hibernation state. In a robustly designed system, emergency unload is limited to rare scenarios, such as battery removal during operation.

### **6.4.6.3 Power switch design considerations**

In systems that use the Hitachi Travelstar 60GH & 40GN consideration should be given to the design of the system power switch.

Hitachi recommends that the switch operate under control of the BIOS, as opposed to being hardwired. The same recommendation is made for cover-close switches. When a hardwired switch is turned off, emergency unload occurs, as well as the problems cited in section 5.1, "Data loss by power off" on page 19 and section 5.2, "Write Cache" on page 19.

### **6.4.6.4 Test considerations**

Start/stop testing is classically performed to verify head/disk durability. The heads do not land on the disk, so this type of test should be viewed as a test of the load/unload function.

Start/Stop testing should be done by commands through the interface, not by power cycling the drive. Simple power cycling of the drive invokes the emergency unload mechanism and subjects the HDD to nontypical mechanical stress.

Power cycling testing may be required to test the boot-up function of the system. In this case Hitachi recommends that the power-off portion of the cycle contain the sequence specified in section 6.4.6.2, "Required Power-Off Sequence" on page 29. If this is not done, the emergency unload function is invoked and nontypical stress results.

## 6.5 Mechanical specifications

### 6.5.1 Physical dimensions and weight

The following figure lists the dimensions for the drive.

| Models       | Height (mm) | Width (mm) | Length (mm) | Weight (gram) |
|--------------|-------------|------------|-------------|---------------|
| 60 GB        | 12.5±0.2    | 69.85±0.25 | 100.2±0.25  | 155 Max       |
| 40 GB, 30 GB | 9.5±0.2     | 69.85±0.25 | 100.2±0.25  | 99 Max        |
| 20 GB, 10 GB | 9.5±0.2     | 69.85±0.25 | 100.2±0.25  | 95 Max        |

Figure 25. Physical dimensions and weight

### 6.5.2 Mounting hole locations

The mounting hole locations and size of the drive are shown below.

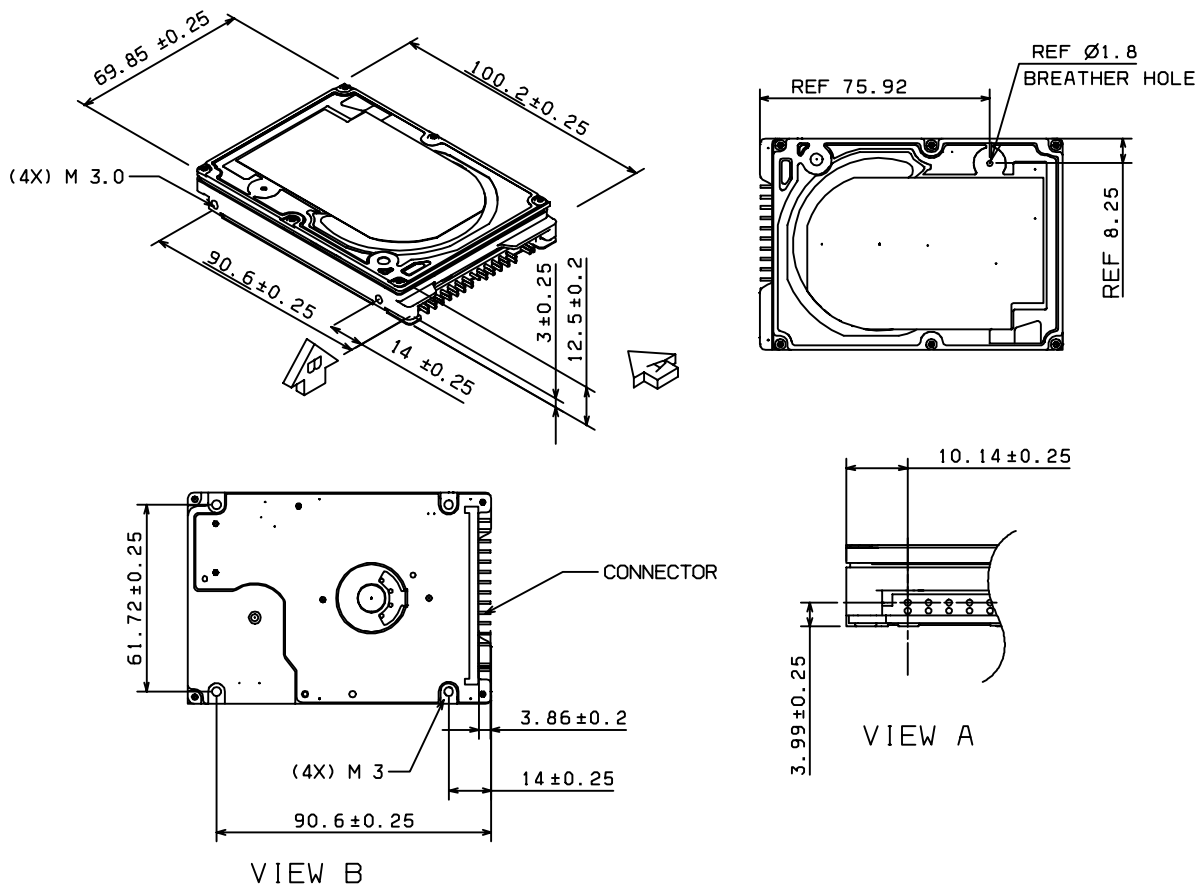

Figure 26. Mounting hole locations of the 60 GB model.

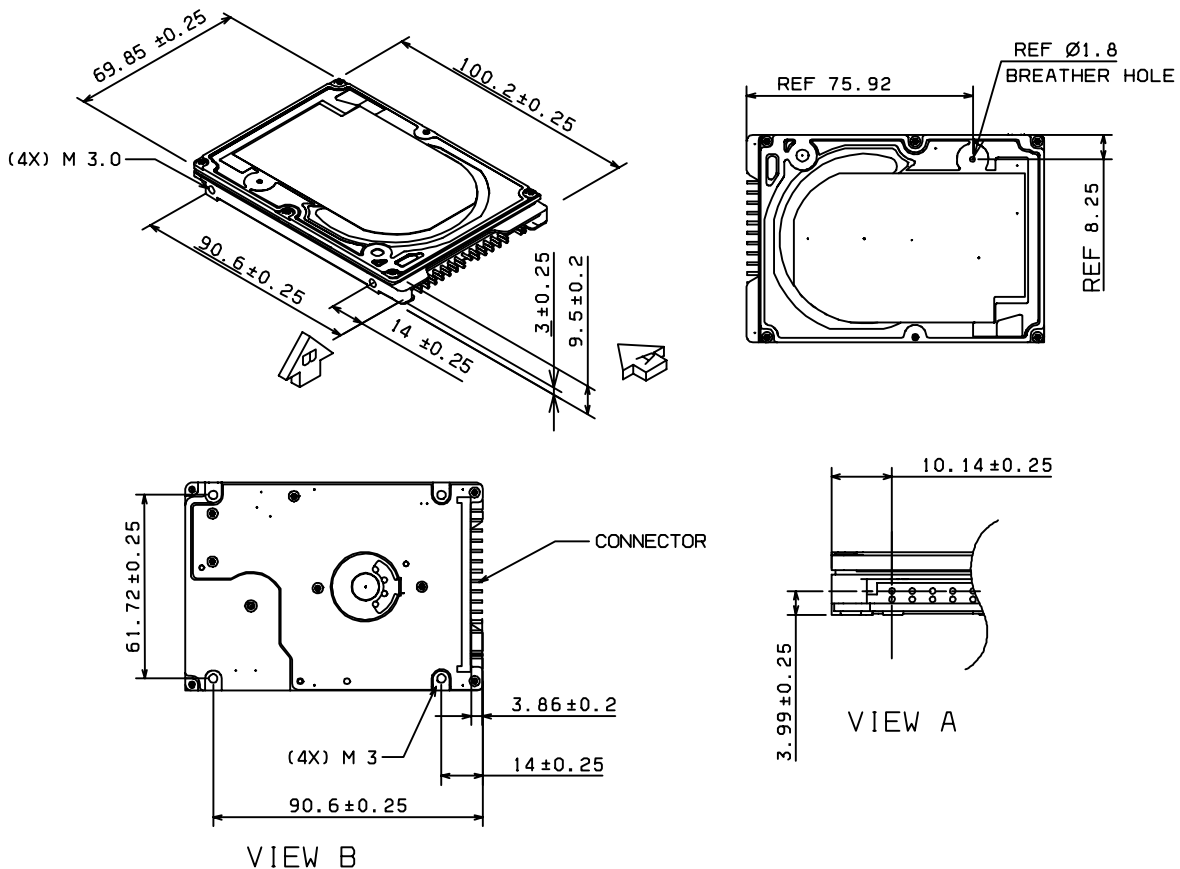

Figure 27. Mounting hole locations of all models except 60 GB model.

### 6.5.3 Connector and jumper description

A jumper is used to designate the drive address as either master or slave. The jumper setting method is described in section 7.10, "Drive address setting" on page 58.

Connector specifications are included in section 7.2, "Interface connector" on page 41.

### 6.5.4 Mounting orientation

The drive will operate in all axes (six directions) and will stay within the specified error rates when tilted  $\pm 5$  degrees from these positions.

Performance and error rate will stay within specification limits if the drive is operated in the other permissible orientations from which it was formatted. Thus a drive formatted in a horizontal orientation will be able to run vertically and vice versa.

The recommended mounting screw torque is  $3.0 \pm 0.5$  kgf-cm.

The recommended mounting screw depth is  $3.0 \pm 0.3$  mm for bottom and  $3.5 \pm 0.5$  mm for horizontal mounting.

The user is responsible for using the appropriate screws or equivalent mounting hardware to mount the drive securely enough to prevent excessive motion or vibration of the drive at seek operation or spindle rotation.

### **6.5.5 Load/unload mechanism**

The head load/unload mechanism is provided to protect the disk data during shipping, movement, or storage. Upon power down, a head unload mechanism secures the heads at the unload position. See section 6.6.4, "Nonoperating shock" on page 36 for additional details.

---

## 6.6 Vibration and shock

All vibration and shock measurements in this section are for drives without mounting attachments for systems. The input level shall be applied to the normal drive mounting points.

Vibration tests and shock tests are to be conducted by mounting the drive to a table using the bottom four mounting holes.

### 6.6.1 Operating vibration

The drive will operate without a hard error while being subjected to the following vibration levels.

#### 6.6.1.1 Random vibration

The test consists of 30 minutes of random vibration using the power spectral density (PSD) levels specified in C-S 1-9711-002 (1990-03) as V5L. The vibration test level for V5L is 0.67 G RMS (Root Mean Square).

---

| Random vibration PSD profile Breakpoint |                    |
|---|--------------------|
| Hz                                      | G <sup>2</sup> /Hz |
| 5                                       | 2.0 x E-5          |
| 17                                      | 1.1 x E-3          |
| 45                                      | 1.1 x E-3          |
| 48                                      | 8.0 x E-3          |
| 62                                      | 8.0 x E-3          |
| 65                                      | 1.0 x E-3          |
| 150                                     | 1.0 x E-3          |
| 200                                     | 5.0 x E-4          |
| 500                                     | 5.0 x E-4          |

---

Figure 28. Random vibration PSD profile breakpoints (operating)

#### 6.6.1.2 Swept sine vibration

---

|                  | Swept sine vibration (zero to peak 5 to 500 to 5 Hz sine wave)          | Sweep rate (oct/min) |
|------------------|---|----------------------|
| 60-GB model      | 1 G (5-300 Hz)<br>1 G (300 Hz) - 0.33 G (350 Hz)<br>0.33 G (350-500 Hz) | 2.0                  |
| All other models | 1 G (5-500 Hz)  | 2.0                  |

---

Figure 29. Swept sine vibration

## 6.6.2 Nonoperating vibration

The disk drive withstands the following vibration levels without any loss or permanent damage.

### 6.6.2.1 Random vibration

The test consists of a random vibration applied in each of three mutually perpendicular axes for a duration of 15 minutes per axis. The PSD levels for the test simulating the shipping and relocation environment is shown below.

---

| Hz  | G <sup>2</sup> /Hz |
|-----|--------------------|
| 2.5 | 0.001              |
| 5   | 0.03               |
| 40  | 0.018              |
| 500 | 0.018              |

*Note: Overall RMS (root mean square) level of vibration is 3.01 G rms.*

---

Figure 30. Random Vibration PSD Profile Breakpoints (nonoperating)

### 6.6.2.2 Swept sine vibration

- 5 G (zero-to-peak), 10 to 500 to 10 Hz sine wave
- 0.5 oct/min sweep rate
- 25.4 mm (peak-to-peak) displacement, 5 to 10 to 5 Hz

## 6.6.3 Operating shock

The hard disk drive meets the criteria in the table below while operating under these conditions:

- The shock test consists of 10 shock inputs in each axis and direction for a total of 60.
- There must be a minimum of 3 seconds delay between shock pulses.
- The disk drive will operate without a hard error while being subjected to the following half-sine shock pulse.

---

| Model            | Duration of 2 ms | Duration of 11 ms |
|------------------|------------------|-------------------|
| 60-GB model      | 150 G            | 15 G              |
| all other models | 200 G            | 15 G              |

---

Figure 31. Operating shock

The input level shall be applied to the normal disk drive subsystem mounting points used to secure the drive in a normal system.

## 6.6.4 Nonoperating shock

The drive withstands the following half-sine shock pulse without any data loss or permanent damage.

---

| <b>Models</b> | <b>Duration of 1 ms</b> | <b>Duration of 11 ms</b> |
|---------------|-------------------------|--------------------------|
| 60 GB         | 700 G                   | 120 G                    |
| All others    | 800 G                   | 120 G                    |

---

Figure 32. Nonoperating shock

The shocks are applied for each direction of the drive for three mutually perpendicular axes, one axis at a time. Input levels are measured on a base plate where the drive is attached with four screws.

---

## 6.7 Acoustics

### 6.7.1 Sound power level

The criteria of A-weighted sound power level are described below.

Measurements are to be taken in accordance with ISO 7779. The mean of the sample of 40 drives is to be less than the typical value. Each drive is to be less than the maximum value. The drives are to meet this requirement in both board down orientations.

---

| A-weighted Sound Power        | Typical (Bels) |           | Maximum (Bels) |           |
|-------------------------------|----------------|-----------|----------------|-----------|
|                               | Idle           | Operating | Idle           | Operating |
| <b>48 GB model</b>            | 2.5            | 3.5       | 2.7            | 3.8       |
| <b>30 GB and 20 GB models</b> | 2.4            | 3.1       | 2.6            | 3.3       |
| <b>All other models</b>       | 2.1            | 2.7       | 2.4            | 2.9       |

---

Figure 33. Weighted sound power

The background power levels of the acoustic test chamber for each octave band are to be recorded.

Sound power tests are to be conducted with the drive supported by spacers so that the lower surface of the drive be located 25±3 mm above from the chamber floor. No sound absorbing material shall be used.

The acoustical characteristics of the disk drive are measured under the following conditions:

#### Mode definitions

- Idle mode: Power on, disks spinning, track following, unit ready to receive and respond to control line commands.
- Operating mode: Continuous random cylinder selection and seek operation of the actuator with a dwell time at each cylinder. The seek rate for the drive can be calculated as shown below.

$$N_s = 0.4 / (T_t + T_1)$$

where:

$N_s$  = average seek rate in seeks/s

$T_t$  = published seek time from one random track to another without including rotational latency

$T_1$  = equivalent time in seconds for the drive to rotate by half a revolution

## 6.7.2 Discrete tone penalty

Discrete tone penalties are added to the A-weighted sound power ( $L_w$ ) with the following formula only when determining compliance.

$$L_{wt(spec)} = L_w + 0.1P_t + 0.3 < 4.0 \text{ (Bels)}$$

*where*

$L_w$  = A-weighted sound power level

$P_t$  = Value of discrete tone penalty =  $dL_t - 6.0$ (dBA)

$dL_t$  = Tone-to-noise ratio taken in accordance with ISO 7779 at each octave band.

---

## 6.8 Identification labels

The following labels are affixed to every drive:

- A label which is placed on the top of the head disk assembly containing the statement "Made by Hitachi" or equivalent, part number, EC number, and FRU number.
- A bar code label which is placed on the disk drive based on user request. The location on the disk drive is to be designated in the drawing provided by the user.
- Labels containing the vendor's name, disk drive model number, serial number, place of manufacture, and UL/CSA logos.
- The presence of labels containing jumper information depends on the customer.

---

## 6.9 Electromagnetic compatibility

When installed in a suitable enclosure and exercised with a random accessing routine at maximum data rate, the drive meets the following worldwide electromagnetic compatibility (EMC) requirements:

- United States Federal Communications Commission (FCC) Rules and Regulations (Class B), Part 15. RFI Suppression German National Requirements
- EU EMC Directive, Technical Requirements and Conformity Assessment Procedures

### 6.9.1 CE Mark

The product is certified for compliance with EC directive 89/336/EEC. The EC marking for the certification appears on the drive.

### 6.9.2 C-Tick Mark

The product complies with the Australian EMC standard "Limits and methods of measurement of radio disturbance characteristics of information technology equipment, AS/NZS 3548:1995 Class B."

---

## **6.10 Safety**

### **6.10.1 UL and CSA approval**

The product is qualified per UL (Underwriters Laboratory) 1950 Third Edition and CAN/CSA C22.2 No.950-M95 Third Edition, for the use in Information Technology Equipment, including Electric Business Equipment. The UL Recognition or the CSA certification is maintained for the product life. The UL and C-UL recognition mark or the CSA monogram for CSA certification appears on the drive.

### **6.10.2 IEC compliance**

All models of the Hitachi Travelstar 60GH & 40GN comply with IEC 950:1991 +A1-4.

### **6.10.3 German Safety Mark**

All models of the Hitachi Travelstar 60GH & 40GN are approved by TUV on Test Requirement: EN 60950:1992+A1-4, but the GS mark has not been obtained.

### **6.10.4 Flammability**

The printed circuit boards used in this product are made of material with a UL recognized flammability rating of V-1 or better. The flammability rating is marked or etched on the board. All other parts not considered electrical components are made of material with a UL recognized flammability rating of V-1 or better except minor mechanical parts.

### **6.10.5 Secondary circuit protection**

This product utilizes printed circuit wiring that must be protected against the possibility of sustained combustion due to circuit or component failures as defined in C-B 2-4700-034 (Protection Against Combustion). Adequate secondary over current protection is the responsibility of the using system.

The user must protect the drive from its electrical short circuit problem. A 10 amp limit is required for safety purpose.

---

## **6.11 Packaging**

Drives are packed in ESD protective bags and shipped in appropriate containers.

---

## 7.0 Electrical interface specifications

---

### 7.1 Cabling

The maximum cable length from the host system to the hard disk drive plus circuit pattern length in the host system shall not exceed 18 inches.

---

### 7.2 Interface connector

The signal connector for AT attachment is designed to mate with the 50 pin plug specified in Annex A, Connectors and Cable Assembly, of the ATA/ATAPI-5 document.

The figure below and Figure 6.5.2 on page 31 show the connector location and physical pin location.

---

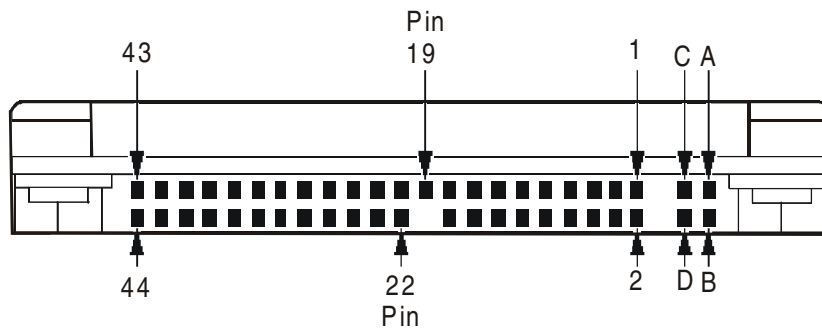

Pin position 20 is left blank for correct connector insertion.

Pin positions A, B, C, and D are used for the drive address setting. (Refer to Figure 48 on page 58 for correct address setting.)

---

Figure 34. Interface connector pin assignments

## 7.3 Signal definitions

The pin assignments of interface signals are listed as follows:

| PIN | SIGNAL     | I/O   | Type    | PIN  | SIGNAL      | I/O   | Type    |
|-----|------------|-------|---------|------|-------------|-------|---------|
| 01  | RESET-     | I     | TTL     | 02   | GND         |       |         |
| 03  | DD07       | I/O   | 3-state | 04   | DD08        | I/O   | 3-state |
| 05  | DD06       | I/O   | 3-state | 06   | DD09        | I/O   | 3-state |
| 07  | DD05       | I/O   | 3-state | 08   | DD10        | I/O   | 3-state |
| 09  | DD04       | I/O   | 3-state | 10   | DD11        | I/O   | 3-state |
| 11  | DD03       | I/O   | 3-state | 12   | DD12        | I/O   | 3-state |
| 13  | DD02       | I/O   | 3-state | 14   | DD13        | I/O   | 3-state |
| 15  | DD01       | I/O   | 3-state | 16   | DD14        | I/O   | 3-state |
| 17  | DD00       | I/O   | 3-state | 18   | DD15        | I/O   | 3-state |
| 19  | GND        |       |         | (20) | Key         |       |         |
| 21  | DMARQ      | O     | 3-state | 22   | GND         |       |         |
| 23  | DIOW-(* )  | I     | TTL     | 24   | GND         |       |         |
| 25  | DIOR-(* )  | I     | TTL     | 26   | GND         |       |         |
| 27  | IORDY(* )  | O     | OD      | 28   | CSEL        | I     | TTL     |
| 29  | DMACK-     | I     | TTL     | 30   | GND         |       |         |
| 31  | INTRQ      | O     | 3-state | 32   | IOCS16-(* ) | O     | OD      |
| 33  | DA01       | I     | TTL     | 34   | PDIAG-      | I/O   | OD      |
| 35  | DA00       | I     | TTL     | 36   | DA02        | I     | TTL     |
| 37  | CS0-       | I     | TTL     | 38   | CS1-        | I     | TTL     |
| 39  | DASP-      | I/O   | OD      | 40   | GND         |       |         |
| 41  | + 5V logic | power |         | 42   | + 5V motor  | power |         |
| 43  | GND        |       |         | 44   | (reserved)  |       |         |

|                 |   |
|-----------------|---|
| <b>O</b>        | designates an output from the drive                     |
| <b>I</b>        | designates an input to the drive                        |
| <b>I/O</b>      | designates an input/output common                       |
| <b>OD</b>       | designates an Open-Drain output                         |
| <b>power</b>    | designates a power supply to the drive                  |
| <b>reserved</b> | designates reserved pins which must be left unconnected |

Figure 35. Signal definition

The signal lines marked with (\*) are redefined during the Ultra DMA protocol to provide special functions. These lines change from the conventional to special definitions at the moment the host decides to allow a DMA burst, if the Ultra DMA transfer mode was previously chosen via SetFeatures. The drive becomes aware of this change upon assertion of the DMACK- line. These lines revert back to their original definitions upon the deassertion of DMACK- at the termination of the DMA burst.

|                        | <b>Special Definition<br/>(for Ultra DMA)</b> | <b>Conventional Definition</b> |
|------------------------|---|--------------------------------|
| <b>Write Operation</b> | DDMARDY-                                      | IORDY                          |
|                        | HSTROBE                                       | DIOR-                          |
|                        | STOP  | DIOW-                          |
| <b>Read Operation</b>  | HDMARDY-                                      | DIOR-                          |
|                        | DSTROBE                                       | IORDY                          |
|                        | STOP  | DIOW-                          |

Figure 36. Special signal definitions for Ultra DMA

---

## 7.4 Signal descriptions

### **DD00–DD15**

A 16-bit bi-directional data bus between the host and the drive. The lower 8 lines, DD00-07, are used for Register and ECC access. All 16 lines, DD00–15, are used for data transfer. These are 3-state lines with 24 mA current sink capability.

### **DA00–DA02**

These are addresses used to select the individual register in the drive.

### **CS0-**

The chip select signal generated from the Host address bus. When active, one of the Command Block Registers [Data, Error (Features when written), Sector Count, Sector Number, Cylinder Low, Cylinder High, Drive/Head and Status (Command when written) register] can be selected.

### **CS1-**

The chip select signal generated from the Host address bus. When active, one of the Control Block Registers [Alternate Status (Device Control when written) and Drive Address register] can be selected.

### **RESET-**

This line is used to reset the drive. It shall be kept at a Low logic state during power up and kept High thereafter.

### **DIOW-**

The rising edge of this signal holds data from the data bus to a register or data register of the drive.

### **DIOR-**

When this signal is low, it enables data from a register or data register of the drive onto the data bus. The data on the bus shall be latched on the rising edge of DIOR-.

### **INTRQ**

The interrupt is enabled only when the drive is selected and the host activates the -IEN bit in the Device Control Register. Otherwise, this signal is in high impedance state regardless of the state of the IRQ bit. The interrupt is set when the IRQ bit is set by the drive CPU. The IRQ is reset to zero by a host read of the status register or a write to the Command Register. This signal is a 3-state line with 24 mA of sink capability.

### **IOCS16-**

A signal indicating to the host that a 16-bit wide data register has been addressed and that the drive is prepared to send or receive a 16-bit wide data word. This signal is an Open-Drain output with 24 mA sink capability and an external resistor is needed to pull this line to 5 volts.

### **DASP-**

This is a time-multiplexed signal which indicates that a drive is active or that device 1 is present. This signal is driven by an Open-Drain driver and internally pulled up to 5 volts through a 10 k $\Omega$  resistor. During a Power-On initialization or after RESET- is negated, DASP- shall be asserted by Device 1 within 400 ms to indicate that device 1 is present. Device 0 shall allow up to 450 ms for device 1 to assert DASP-. If device 1 is not present, device 0 may assert DASP- to drive an LED indicator. The DASP- signal shall be negated following acceptance of the first valid command by device 1. Anytime after negation of DASP-, either drive may assert DASP- to indicate that a drive is active.

**PDIAG-**

This signal shall be asserted by device 1 to indicate to device 0 that it has completed the diagnostics. This line is pulled up to 5 volts in the drive through a 10 k $\Omega$  resistor.

Following a Power On Reset, software reset, or RESET-, drive 1 shall negate PDIAG- within 1 ms (to indicate to device 0 that it is busy). Drive 1 shall then assert PDIAG- within 30 seconds to indicate that it is no longer busy and is able to provide status.

Following the receipt of a valid Execute Drive Diagnostics command, device 1 shall negate PDIAG- within 1 ms to indicate to device 0 that it is busy and has not yet passed its drive diagnostics. If device 1 is present then device 0 shall wait up to 6 seconds from the receipt of a valid Execute Drive Diagnostics command for drive 1 to assert PDIAG-. Device 1 should clear BSY before asserting PDIAG-, as PDIAG- is used to indicate that device 1 has passed its diagnostics and is ready to post status. If DASP- was not asserted by device 1 during reset initialization, device 0 shall post its own status immediately after it completes diagnostics and clears the device 1 Status register to 00h. Device 0 may be unable to accept commands until it has finished its reset procedure and is ready (DRDY=1).

**CSEL (Cable Select)**

This signal is monitored to determine the drive address (master or slave) when the jumper on the interface connector is at Position-3.

When CSEL is at ground or is at a low level, the drive works as a Master. If CSEL is open or is at a logical high level, the drive works as a Slave.

The signal level of CSEL to one drive should be different from the signal level to another drive on the same AT interface cable to avoid master-master or slave-slave configurations.

**KEY**

Pin position 20 has no connection pin. It is recommended to close the respective position of the cable connector in order to avoid incorrect insertion.

**IORDY**

This signal is an indication to the host that the drive is ready to complete the current I/O cycle. This line is driven low at the falling edge of DIOR- or DIOW- when the drive needs some additional WAIT cycle(s) to extend the PIO cycle. This line can be connected to the host IORDY signal in order to insert a WAIT state(s) into the host PIO cycle. This signal is an Open-Drain output with 24 mA sink capability.

**5V Power**

There are two input pins for the +5 V power supply. One is the "+5 V Logic" input pin and the second is the "+5 V Motor" input pin. These two input pins are tied together within the drive.

**DMACK-**

This signal shall be used by the host in response to DMARQ to either acknowledge that data has been accepted, or that data is available.

This signal is internally pulled up to 5 Volt through a 15 k $\Omega$  resistor with a resistor tolerance value of -50% to +100%.

**DMARQ**

This signal is used for DMA data transfers between the host and drive. It shall be asserted by the drive when it is ready to transfer data to or from the host. The direction of data transfer is controlled by -HIOR and -HIOW signals. This signal is used in a handshake mode with DMACK-. This signal is a 3-state line with 24 mA sink capability and internally pulled down to GND through a 10 k $\Omega$  resistor.

**HDMARDY- (Ultra DMA)**

This signal is used only for Ultra DMA data transfers between host and drive.

The signal HDMARDY- is a flow control signal for Ultra DMA data in bursts. This signal is held asserted by the host to indicate to the device that the host is ready to receive Ultra DMA data in transfers. The host may negate HDMARDY- to pause an Ultra DMA data in transfer.

**HSTROBE (Ultra DMA)**

This signal is used only for Ultra DMA data transfers between host and drive.

The signal HSTROBE is the data out strobe signal from the host for an Ultra DMA data out transfer. Both the rising and falling edge of HSTROBE latch the data from DD (15:0) into the device. The host may stop toggling HSTROBE to pause an Ultra DMA data out transfer.

**STOP (Ultra DMA)**

This signal is used only for Ultra DMA data transfers between host and drive.

The STOP signal shall be asserted by the host prior to initiation of an Ultra DMA burst. A STOP shall be negated by the host before data is transferred in an Ultra DMA burst. Assertion of STOP by the host during or after data transfer in an Ultra DMA mode signals the termination of the burst.

**DDMARDY- (Ultra DMA)**

This signal is used only for Ultra DMA data transfers between host and drive.

The signal DDMARDY- is a flow control signal for Ultra DMA data out bursts. This signal is held asserted by the device to indicate to the host that the device is ready to receive Ultra DMA data out transfers. The device may negate DDMARDY- to pause an Ultra DMA data out transfer.

**DSTROBE (Ultra DMA)**

This signal is used only for Ultra DMA data transfers between host and drive.

The signal DSTROBE is the data in strobe signal from the device for an Ultra DMA data in transfer. Both the rising and the falling edge of DSTROBE latch the data from DD (15:0) into the host. The device may stop toggling DSTROBE to pause an Ultra DMA data in transfer.

## 7.5 Interface logic signal levels

The interface logic signals have the following electrical specifications:

|          |                       |                        |
|----------|-----------------------|------------------------|
| Inputs   | Input High Voltage    | 2.0 V min./5.5 V max.  |
|          | Input Low Voltage     | -0.5 V min./0.8 V max. |
| Outputs: | Output High Voltage   | 2.4 V min.             |
|          | Output Low Voltage    | 0.5 V max.             |
| Current  | Driver Sink Current   | 24 mA min.             |
|          | Driver Source Current | -400 $\mu$ A min.      |

## 7.6 Reset timings

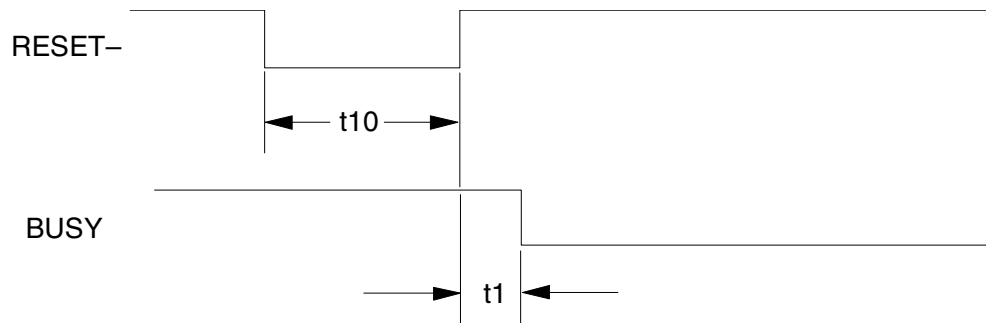

|     | PARAMETER DESCRIPTION   | Min.<br>( $\mu$ s) | Max.<br>( $\mu$ s) |
|-----|-------------------------|--------------------|--------------------|
| t1  | RESET- high to Not BUSY | -                  | 9.5                |
| t10 | RESET- low width        | 25                 | -                  |

Figure 37. System reset timings

## 7.7 PIO timings

The PIO cycle timings meet Mode 4 of the ATA-5 description.

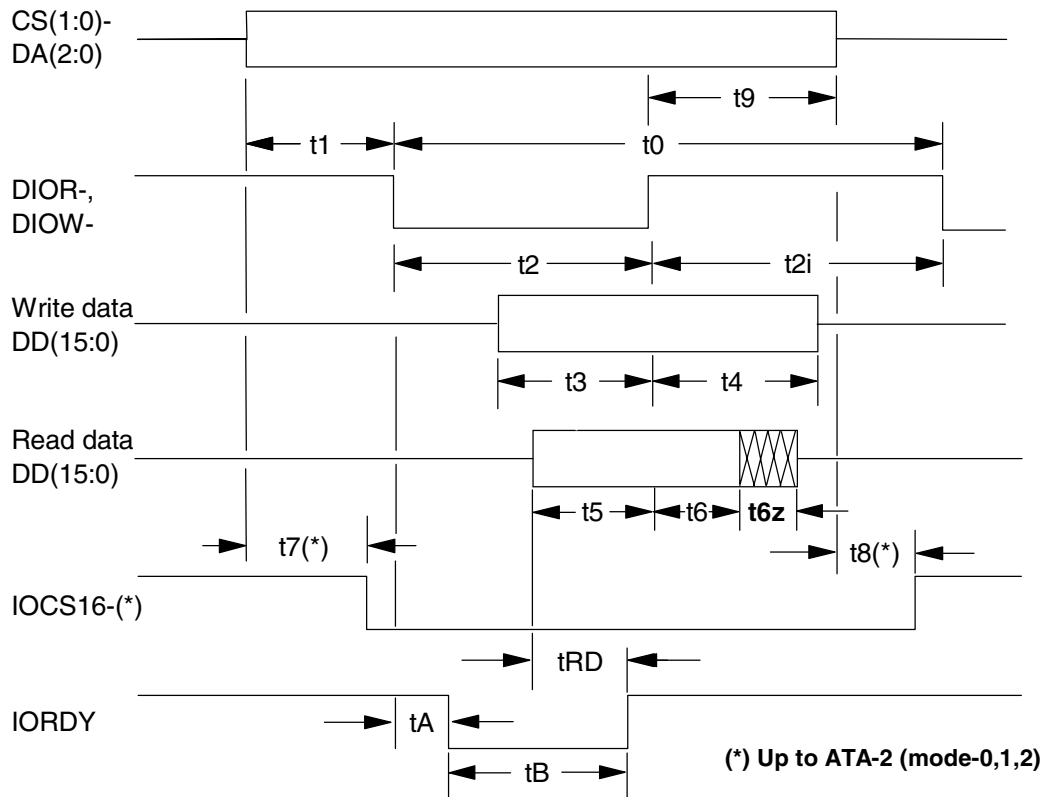

|          | PARAMETER DESCRIPTION              | MIN (ns) | MAX. (ns) |
|----------|------------------------------------|----------|-----------|
| $t_0$    | Cycle time                         | 120      | –         |
| $t_1$    | Address valid to DIOR-/DIOW- setup | 25       | –         |
| $t_2$    | DIOR-/DIOW- pulse width            | 70       | –         |
| $t_{2i}$ | DIOR-/DIOW- recovery time          | 25       | –         |
| $t_3$    | DIOW- data setup                   | 20       | –         |
| $t_4$    | DIOW- data hold                    | 10       | –         |
| $t_5$    | DIOR- data setup                   | 20       | –         |
| $t_6$    | DIOR- data hold                    | 5        | –         |
| $t_{6z}$ | DIOR- data tristate                | –        | 30        |
| $t_7^*$  | Address valid to IOCS16- assertion | –        | 40        |
| $t_8^*$  | Address valid to IOCS16- released  | –        | 30        |
| $t_9$    | DIOR-/DIOW- to address valid hold  | 10       | –         |
| $t_{RD}$ | Read data valid to IORDY active    | 0        | –         |
| $t_A$    | IORDY setup width                  | –        | 35        |
| $t_B$    | IORDY pulse width                  | –        | 1,250     |

Figure 38. PIO cycle timings

## 7.8 Multiword DMA timings

The Multiword DMA timings meet Mode 2 of the ATA-3 description.

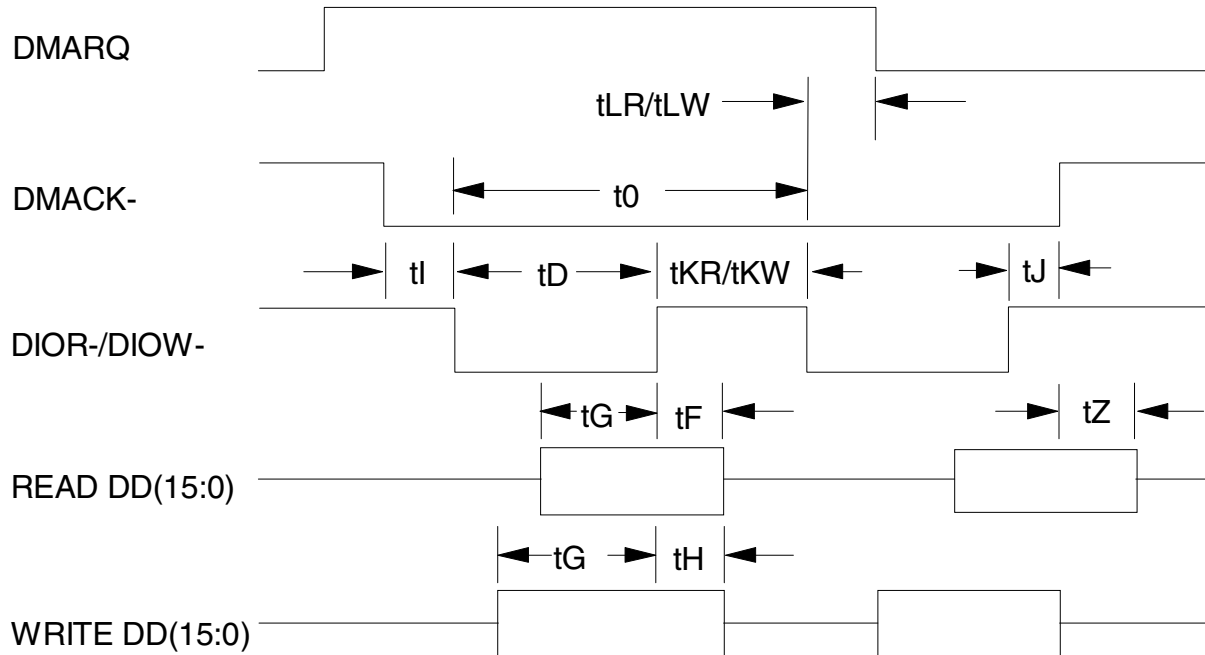

|              | PARAMETER DESCRIPTION                                 | MIN (ns) | MAX (ns) |
|--------------|---|----------|----------|
| $t_0$        | Cycle time  | 120      | –        |
| $t_D$        | DIOR-/DIOW- asserted pulse width                      | 70       | –        |
| $t_E$        | DIOR- data access                                     | –        | 50       |
| $t_F$        | DIOR- data hold                                       | 5        | –        |
| $t_G$        | DIOR-/DIOW- data setup                                | 20       | –        |
| $t_H$        | DIOW- data hold                                       | 10       | –        |
| $t_I$        | DMACK- to DIOR-/DIOW- setup                           | 0        | –        |
| $t_J$        | DIOR-/DIOW- to DMACK- hold                            | 5        | –        |
| $t_{KR/tKW}$ | DIOR- negated pulse width / DIOW- negated pulse width | 25       | –        |
| $t_{LR/tLW}$ | DIOR- to DMARQ delay / DIOW- to DMARQ delay           | –        | 35       |
| $t_Z$        | DMACK- to read data released                          | –        | 25       |

Figure 39. Multiword DMA cycle timings

## 7.9 Ultra DMA timings

The Ultra DMA timings meet Mode 0, 1, 2, 3, 4, and 5 of the Ultra DMA Protocol.

### 7.9.1 Initiating Read DMA

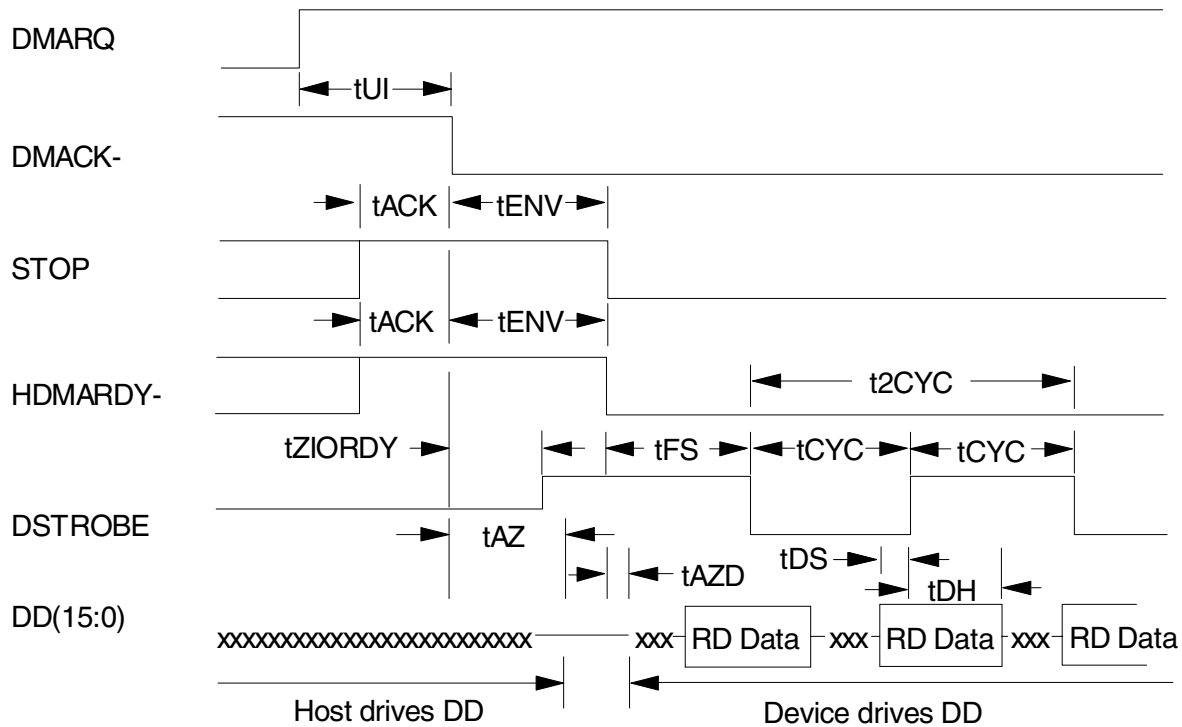

|         | PARAMETER DESCRIPTION                              | MODE 0   |          | MODE 1   |          | MODE 2   |          | MODE 3   |          | MODE 4   |          | MODE 5   |          |
|---------|--|----------|----------|----------|----------|----------|----------|----------|----------|----------|----------|----------|----------|
|         |  | MIN (ns) | MAX (ns) | MIN (ns) | MAX (ns) | MIN (ns) | MAX (ns) | MIN (ns) | MAX (ns) | MIN (ns) | MAX (ns) | MIN (ns) | MAX (ns) |
| tUI     | Unlimited interlock time                           | 0        | -        | 0        | -        | 0        | -        | 0        | -        | 0        | -        | 0        | -        |
| tACK    | Setup time for DMACK-                              | 20       | -        | 20       | -        | 20       | -        | 20       | -        | 20       | -        | 20       | -        |
| tENV    | Envelope time                                      | 20       | 70       | 20       | 70       | 20       | 70       | 20       | 55       | 20       | 55       | 20       | 50       |
| tZIORDY | Minimum time before driving IORDY                  | 0        | -        | 0        | -        | 0        | -        | 0        | -        | 0        | -        | 0        | -        |
| tFS     | First DSTROBE time                                 | 0        | 230      | 0        | 200      | 0        | 170      | 0        | 130      | 0        | 120      | -        | 90       |
| tCYC    | Cycle time   | 112      | -        | 73       | -        | 54       | -        | 39       | -        | 25       | -        | 16.8     | -        |
| t2CYC   | Two cycle time                                     | 230      | -        | 154      | -        | 115      | -        | 86       | -        | 57       | -        | 38       | -        |
| tAZ     | Maximum time allowed for output drivers to release | -        | 10       | -        | 10       | -        | 10       | -        | 10       | -        | 10       | -        | 10       |
| tZAD    | Drivers to assert                                  | 0        | -        | 0        | -        | 0        | -        | 0        | -        | 0        | -        | 0        | -        |
| tDS     | Data setup time at host                            | 15       | -        | 10       | -        | 7        | -        | 7        | -        | 5        | -        | 4.8      | -        |
| tDH     | Data hold time at host                             | 5        | -        | 5        | -        | 5        | -        | 5        | -        | 5        | -        | 4.8      | -        |

Figure 40. Ultra DMA cycle timings (Initiating Read)

## 7.9.2 Host Pausing Read DMA

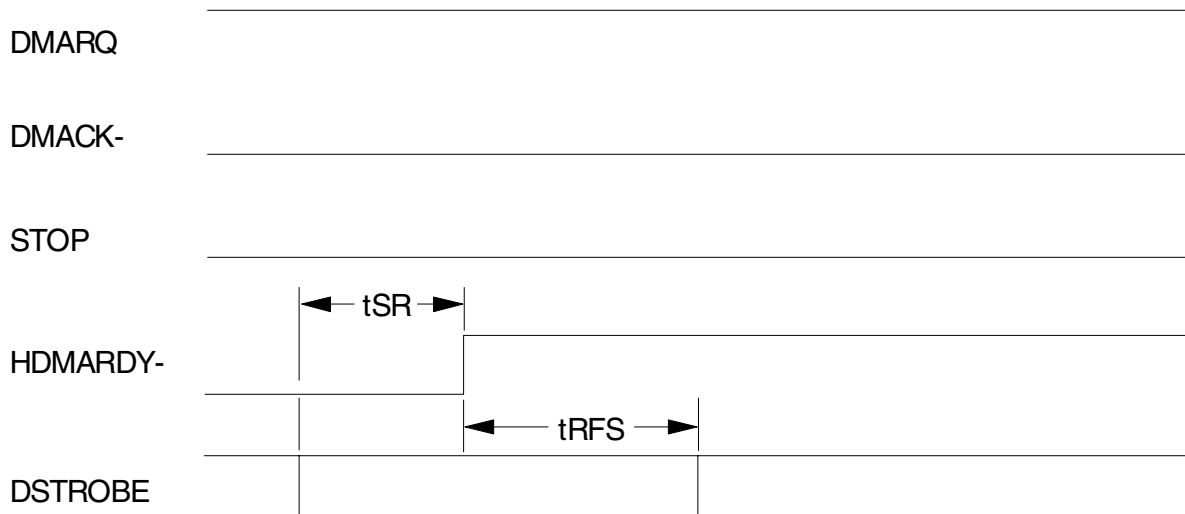

|      | PARAMETER DESCRIPTION          | MODE 0   |          | MODE 1   |          | MODE 2   |          | MODE 3   |          | MODE 4   |          | MODE 5   |          |
|------|--------------------------------|----------|----------|----------|----------|----------|----------|----------|----------|----------|----------|----------|----------|
|      |                                | MIN (ns) | MAX (ns) | MIN (ns) | MAX (ns) | MIN (ns) | MAX (ns) | MIN (ns) | MAX (ns) | MIN (ns) | MAX (ns) | MIN (ns) | MAX (ns) |
| tSR  | DSTROBE to HDMARDY- time       | -        | 50       | -        | 30       | -        | 20       | -        | -        | -        | -        | -        | -        |
| tRFS | HDMARDY- to final DSTROBE time | -        | 75       | -        | 70       | -        | 60       | -        | 60       | -        | 60       | -        | 50       |

*Note: When a host does not satisfy the tSR timing, the host should be ready to receive two more data words after HDMARDY- is negated.*

Figure 41. Ultra DMA cycle timings (Host Pausing Read)

### 7.9.3 Host Terminating Read DMA

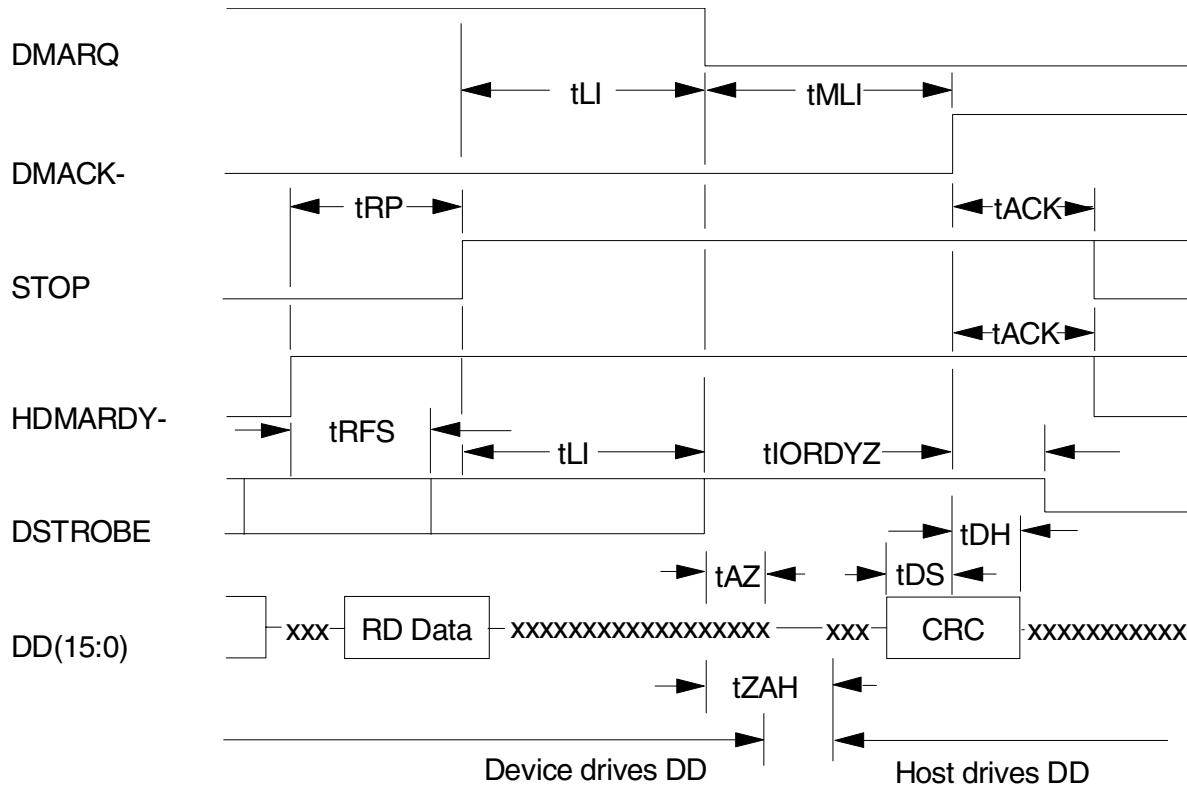

|         | PARAMETER DESCRIPTION                              | MODE 0   |          | MODE 1   |          | MODE 2   |          | MODE 3   |          | MODE 4   |          | MODE 5   |          |
|---------|--|----------|----------|----------|----------|----------|----------|----------|----------|----------|----------|----------|----------|
|         |  | MIN (ns) | MAX (ns) | MIN (ns) | MAX (ns) | MIN (ns) | MAX (ns) | MIN (ns) | MAX (ns) | MIN (ns) | MAX (ns) | MIN (ns) | MAX (ns) |
| tRFS    | HDMARDY- to final DSTROBE time                     | -        | 75       | -        | 70       | -        | 60       | -        | 60       | -        | 60       | -        | 50       |
| tRP     | Ready to pause time                                | 160      | -        | 125      | -        | 100      | -        | 100      | -        | 100      | -        | 85       | -        |
| tLI     | Limited interlock time                             | 0        | 150      | 0        | 150      | 0        | 150      | 0        | 100      | 0        | 100      | 0        | 75       |
| tAZ     | Maximum time allowed for output drivers to release | -        | 10       | -        | 10       | -        | 10       | -        | 10       | -        | 10       | -        | 10       |
| tZAH    | Minimum delay time required for output             | 20       | -        | 20       | -        | 20       | -        | 20       | -        | 20       | -        | 20       | -        |
| tMLI    | Interlock time with minimum                        | 20       | -        | 20       | -        | 20       | -        | 20       | -        | 20       | -        | 20       | -        |
| tDS     | CRC word setup time at device                      | 15       | -        | 10       | -        | 7        | -        | 7        | -        | 5        | -        | 4        | -        |
| tDH     | CRC word hold time at device                       | 5        | -        | 5        | -        | 5        | -        | 5        | -        | 5        | -        | 4.6      | -        |
| tACK    | Hold time for DMACK-                               | 20       | -        | 20       | -        | 20       | -        | 20       | -        | 20       | -        | 20       | -        |
| tIORDYZ | Maximum time before releasing IORDY                | -        | 20       | -        | 20       | -        | 20       | -        | 20       | -        | 20       | -        | 20       |

Figure 42. Ultra DMA cycle timings (Host Terminating Read)

## 7.9.4 Device Terminating Read DMA

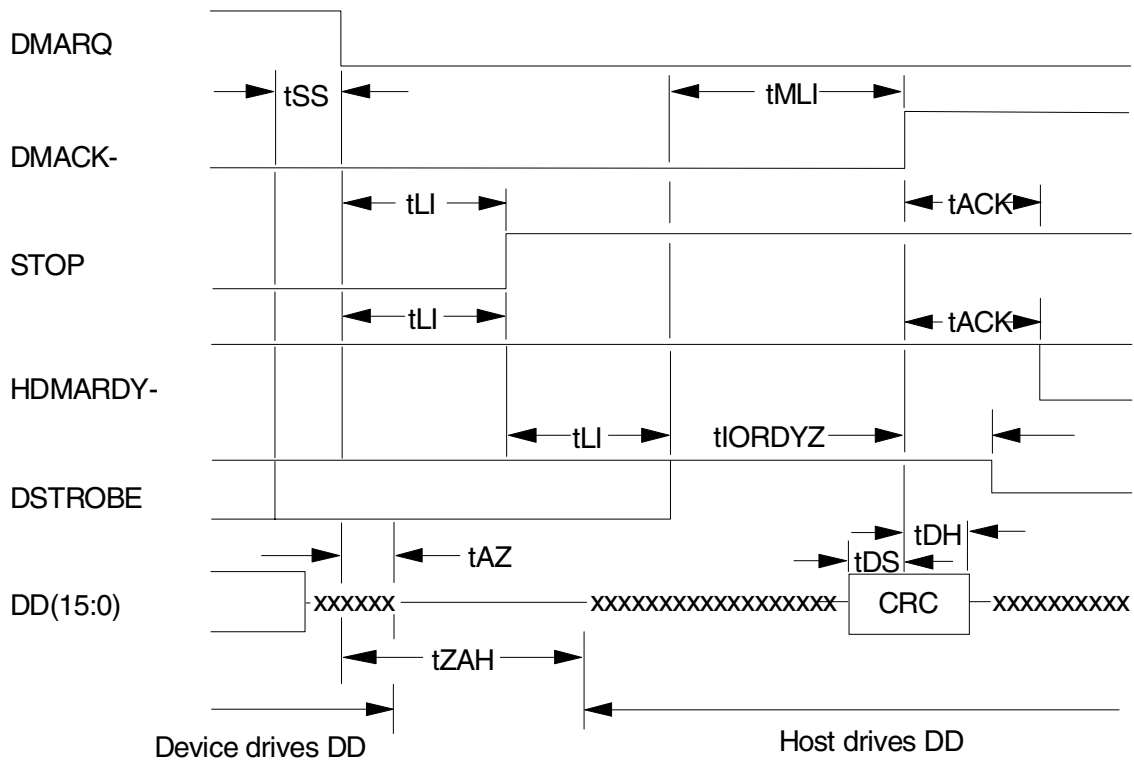

|              | PARAMETER DESCRIPTION                              | MODE 0   |          | MODE 1   |          | MODE 2   |          | MODE 3   |          | MODE 4   |          | MODE 5   |          |
|--------------|--|----------|----------|----------|----------|----------|----------|----------|----------|----------|----------|----------|----------|
|              |  | MIN (ns) | MAX (ns) | MIN (ns) | MAX (ns) | MIN (ns) | MAX (ns) | MIN (ns) | MAX (ns) | MIN (ns) | MAX (ns) | MIN (ns) | MAX (ns) |
| $t_{SS}$     | Time from $DSTROBE$ edge to negation of $DMARQ$    | 50       | -        | 50       | -        | 50       | -        | 50       | -        | 50       | -        | 50       | -        |
| $t_{LI}$     | Limited interlock time                             | 0        | 150      | 0        | 150      | 0        | 150      | 0        | 100      | 0        | 100      | 0        | 75       |
| $t_{AZ}$     | Maximum time allowed for output drivers to release | -        | 10       | -        | 10       | -        | 10       | -        | 10       | -        | 10       | -        | 10       |
| $t_{ZAH}$    | Maximum delay time required for output             | 20       | -        | 20       | -        | 20       | -        | 20       | -        | 20       | -        | 20       | -        |
| $t_{MLI}$    | Interlock time with minimum                        | 20       | -        | 20       | -        | 20       | -        | 20       | -        | 20       | -        | 20       | -        |
| $t_{DS}$     | CRC word setup time at device                      | 15       | -        | 10       | -        | 7        | -        | 7        | -        | 5        | -        | 4        | -        |
| $t_{DH}$     | CRC word hold time at device                       | 5        | -        | 5        | -        | 5        | -        | 5        | -        | 5        | -        | 4.6      | -        |
| $t_{ACK}$    | Hold time for $DMACK-$                             | 20       | -        | 20       | -        | 20       | -        | 20       | -        | 20       | -        | -        | -        |
| $t_{IORDYZ}$ | Maximum time before releasing $IORDY$              | -        | 20       | -        | 20       | -        | 20       | -        | 20       | -        | 20       | -        | -        |

Figure 43. Ultra DMA cycle timings (Device Terminating Read)

## 7.9.5 Initiating Write DMA

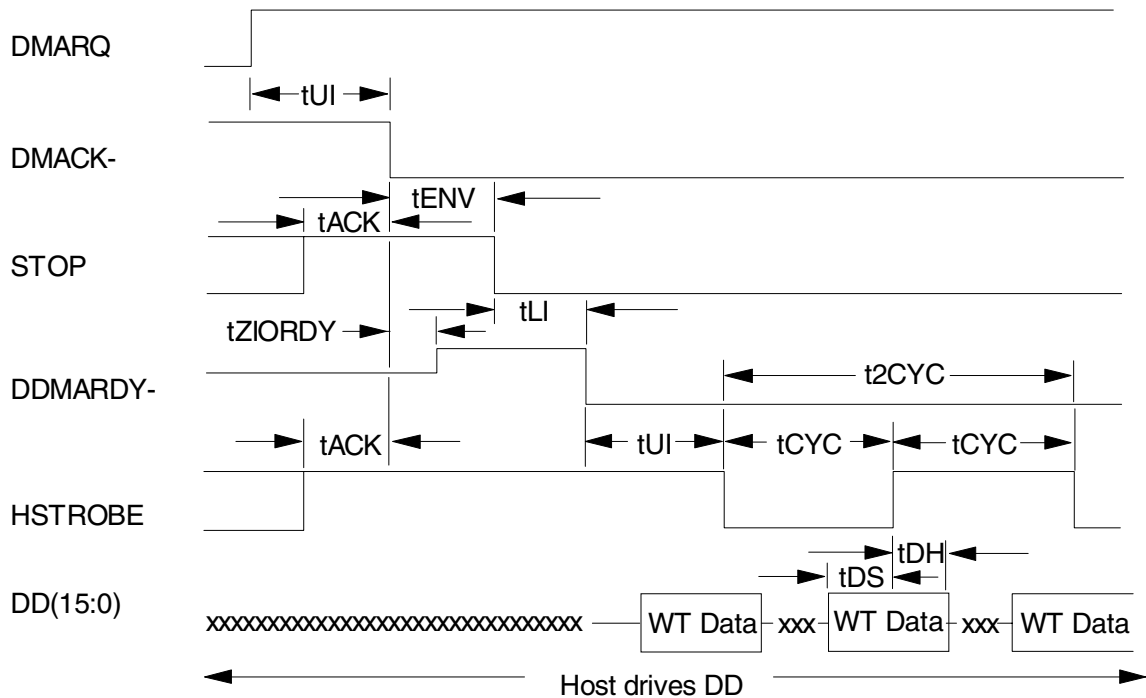

|         | PARAMETER DESCRIPTION             | MODE 0   |          | MODE 1   |          | MODE 2   |          | MODE 3   |          | MODE 4   |          | MODE 5   |          |
|---------|-----------------------------------|----------|----------|----------|----------|----------|----------|----------|----------|----------|----------|----------|----------|
|         |                                   | MIN (ns) | MAX (ns) | MIN (ns) | MAX (ns) | MIN (ns) | MAX (ns) | MIN (ns) | MAX (ns) | MIN (ns) | MAX (ns) | MIN (ns) | MAX (ns) |
| tUI     | Unlimited interlock time          | 0        | –        | 0        | –        | 0        | –        | 0        | –        | 0        | –        | 0        | –        |
| tACK    | Setup time for DMACK-             | 20       | –        | 20       | –        | 20       | –        | 20       | –        | 20       | –        | 20       | –        |
| tENV    | Envelope time                     | 20       | 70       | 20       | 70       | 20       | 70       | 20       | 55       | 20       | 55       | 20       | 55       |
| tZIORDY | Minimum time before driving IORDY | 0        | –        | 0        | –        | 0        | –        | 0        | –        | 0        | –        | 0        | –        |
| tLI     | Limited interlock time            | 0        | 150      | 0        | 150      | 0        | 150      | 0        | 100      | 0        | 100      | 0        | 75       |
| tCYC    | Cycle time                        | 112      | –        | 73       | –        | 54       | –        | 39       | –        | 25       | –        | 16.8     | –        |
| t2CYC   | Two cycle time                    | 230      | –        | 154      | –        | 115      | –        | 86       | –        | 57       | –        | 38       | –        |
| tDS     | Data setup time at device         | 15       | –        | 10       | –        | 7        | –        | 7        | –        | 5        | –        | 4        | –        |
| tDH     | Data Hold time at device          | 5        | –        | 5        | –        | 5        | –        | 5        | –        | 5        | –        | 4.6      | –        |

Figure 44. Ultra DMA cycle timings (Initiating Write)

## 7.9.6 Device Pausing Write DMA

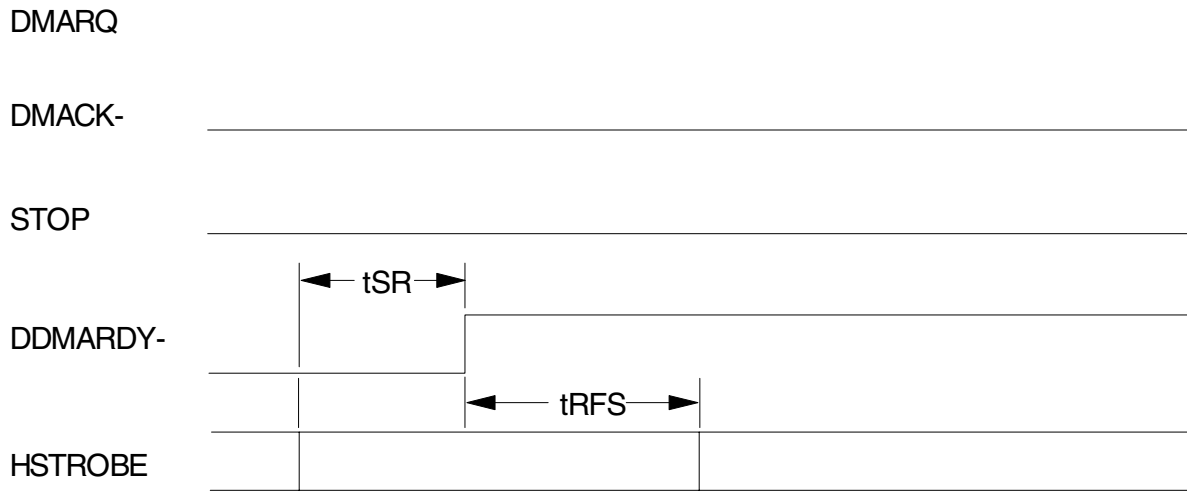

|      | PARAMETER DESCRIPTION          | MODE 0   |          | MODE 1   |          | MODE 2   |          | MODE 3   |          | MODE 4   |          | MODE 5   |          |
|------|--------------------------------|----------|----------|----------|----------|----------|----------|----------|----------|----------|----------|----------|----------|
|      |                                | MIN (ns) | MAX (ns) | MIN (ns) | MAX (ns) | MIN (ns) | MAX (ns) | MIN (ns) | MAX (ns) | MIN (ns) | MAX (ns) | MIN (ns) | MAX (ns) |
| tSR  | HSTROBE to DDMARDY- time       | –        | 50       | –        | 30       | –        | 20       | –        | –        | –        | –        | –        | –        |
| tRFS | DDMARDY- to final HSTROBE time | –        | 75       | –        | 70       | –        | 60       | –        | 60       | –        | 60       | –        | 50       |

*Note: When a device does not satisfy the tSR timing, the device is ready to receive two more data words after DDMARDY- is negated.*

Figure 45. Ultra DMA cycle timings (Device Pausing Write)

## 7.9.7 Device Terminating Write DMA

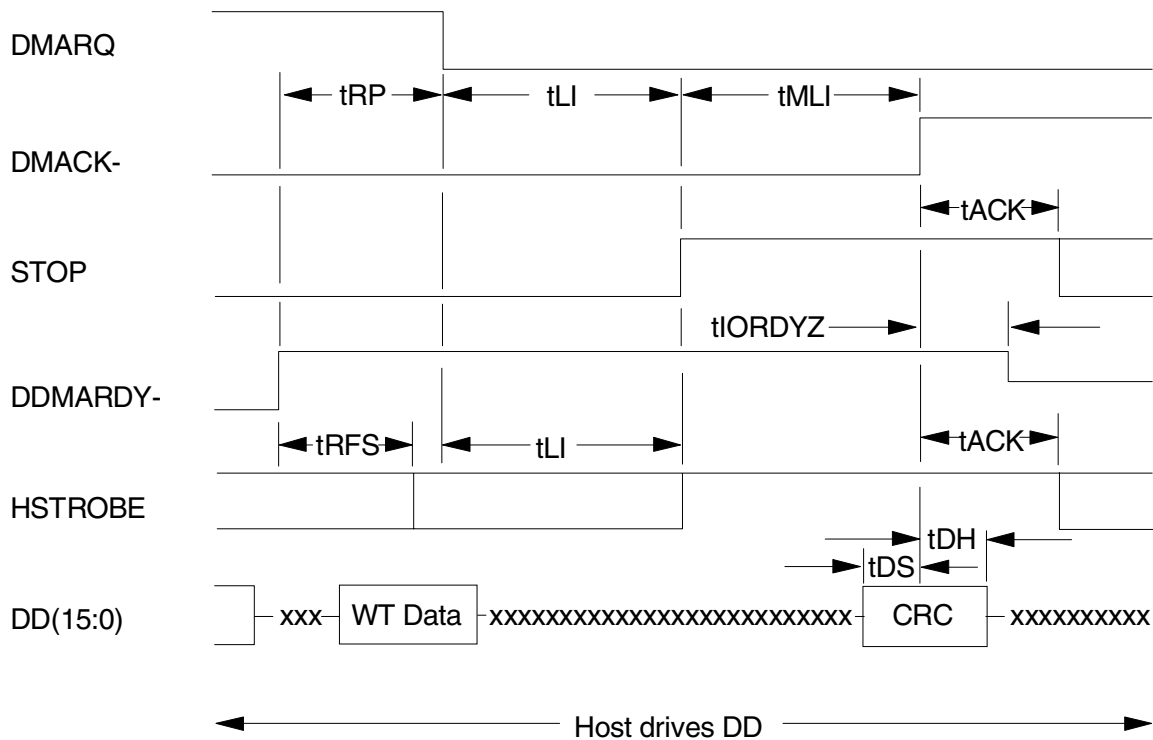

|         | PARAMETER DESCRIPTION               | MODE 0   |          | MODE 1   |          | MODE 2   |          | MODE 3   |          | MODE 4   |          | MODE 5   |          |
|---------|-------------------------------------|----------|----------|----------|----------|----------|----------|----------|----------|----------|----------|----------|----------|
|         |                                     | MIN (ns) | MAX (ns) | MIN (ns) | MAX (ns) | MIN (ns) | MAX (ns) | MIN (ns) | MAX (ns) | MIN (ns) | MAX (ns) | MIN (ns) | MAX (ns) |
| tRFS    | DDMARDY- to final HSTROBE time      | -        | 75       | -        | 70       | -        | 60       | -        | 60       | -        | 60       | -        | 50       |
| tRP     | Ready to pause time                 | 160      | -        | 125      | -        | 100      | -        | 100      | -        | 100      | -        | 85       | -        |
| tLI     | Limited interlock time              | 0        | 150      | 0        | 150      | 0        | 150      | 0        | 100      | 0        | 100      | 0        | 75       |
| tMLI    | Interlocking time with minimum      | 20       | -        | 20       | -        | 20       | -        | 20       | -        | 20       | -        | 20       | -        |
| tDS     | CRC word setup time at device       | 15       | -        | 10       | -        | 7        | -        | 7        | -        | 5        | -        | 4        | -        |
| tDH     | CRC word hold time at device        | 5        | -        | 5        | -        | 5        | -        | 5        | -        | 5        | -        | 4.6      | -        |
| tACK    | Hold time for DMACK-                | 20       | -        | 20       | -        | 20       | -        | 20       | -        | 20       | -        | 20       | -        |
| tIORDYZ | Maximum time before releasing IORDY | -        | 20       | -        | 20       | -        | 20       | -        | 20       | -        | 20       | -        | 20       |

Figure 46. Ultra DMA cycle timings (Device Terminating Write)

## 7.9.8 Host Terminating Write DMA

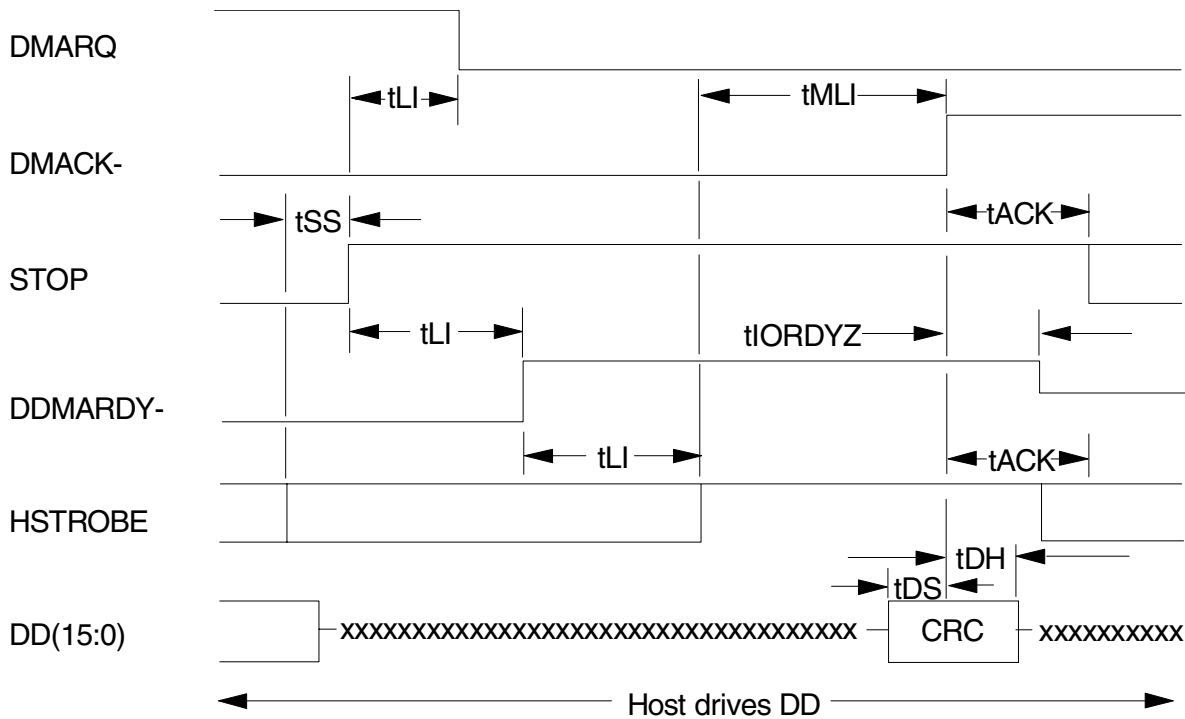

|         | PARAMETER DESCRIPTION                       | MODE 0   |          | MODE 1   |          | MODE 2   |          | MODE 3   |          | MODE 4   |          | MODE 5   |          |
|---------|---|----------|----------|----------|----------|----------|----------|----------|----------|----------|----------|----------|----------|
|         |   | MIN (ns) | MAX (ns) | MIN (ns) | MAX (ns) | MIN (ns) | MAX (ns) | MIN (ns) | MAX (ns) | MIN (ns) | MAX (ns) | MIN (ns) | MAX (ns) |
| tSS     | Time from HSTROBE edge to assertion of STOP | 50       | -        | 50       | -        | 50       | -        | 50       | -        | 50       | -        | 50       | -        |
| tLI     | Limited interlock time                      | 0        | 150      | 0        | 150      | 0        | 150      | 0        | 100      | 0        | 100      | 0        | 75       |
| tMLI    | Interlock time with minimum                 | 20       | -        | 20       | -        | 20       | -        | 20       | -        | 20       | -        | 20       | -        |
| tDS     | CRC word setup time at device               | 15       | -        | 10       | -        | 7        | -        | 7        | -        | 5        | -        | 4        | -        |
| tDH     | CRC word hold time at device                | 5        | -        | 5        | -        | 5        | -        | 5        | -        | 5        | -        | 4.6      | -        |
| tACK    | Hold time for DMACK-                        | 20       | -        | 20       | -        | 20       | -        | 20       | -        | 20       | -        | 20       | -        |
| tIORDYZ | Maximum time before releasing IORDY         | -        | 20       | -        | 20       | -        | 20       | -        | 20       | -        | 20       | -        | 20       |

Figure 47. Ultra DMA cycle timings (Host Terminating Write)

---

## 7.10 Drive address setting

A jumper placed on the interface connector determines the drive address. The three drive addresses are shown below.

---

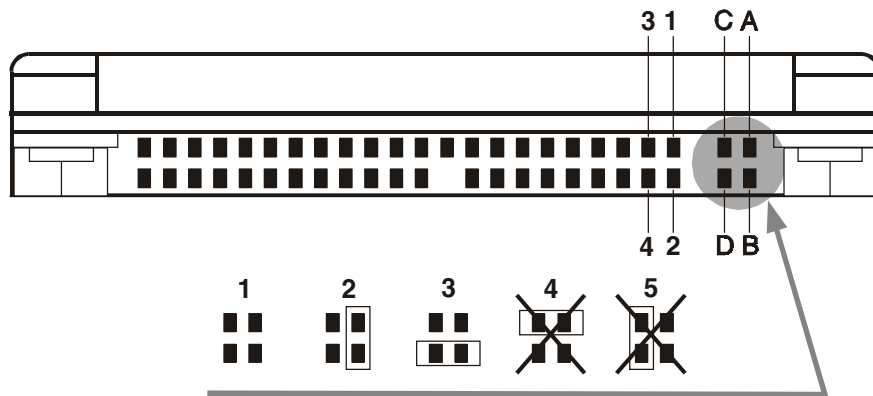

---

Figure 48. Drive address setting

- Setting 1—Device 0 (Master) (no jumper is used)
- Setting 2—Device 1 (Slave)
- Setting 3—Cable Select
- Setting 4—Never attach a jumper here
- Setting 5—Never attach a jumper here

When pin C is grounded, the drive does not spin up at POR.

When the drive address is Cable Select, the address depends on the condition of pin 28 of the AT interface cable. If pin 28 is ground (or low), the drive is a Master. If pin 28 is open (or logic high), the drive is a Slave.

### 7.10.1 Drive default address setting

The default setting of jumper at shipment is Setting 1: no jumper.

## 7.11 Addressing of HDD registers

The host addresses the drive through a set of registers called a Task File. These registers are mapped into the host's I/O space. Two chip select lines (CS0- and CS1-) and three address lines (DA00–02) are used to select one of these registers, while a DIOR- or DIOW- is provided at the specified time.

The chip select line CS0- is used to address the Command Block registers while the CS1- is used to address Control Block registers.

The following table shows the I/ O address map.

| CS0- | CS1- | DA02 | DA01 | DA00 | DIOR- = 0 (Read)               | DIOW- = 0 (Write)   |
|------|------|------|------|------|--------------------------------|---------------------|
|      |      |      |      |      | <b>Command Block Registers</b> |                     |
| 0    | 1    | 0    | 0    | 0    | Data Reg.                      | Data Reg.           |
| 0    | 1    | 0    | 0    | 1    | Error Reg.                     | Features Reg.       |
| 0    | 1    | 0    | 1    | 0    | Sector count Reg.              | Sector count Reg.   |
| 0    | 1    | 0    | 1    | 1    | Sector number Reg.             | Sector number Reg.  |
| 0    | 1    | 1    | 0    | 0    | Cylinder low Reg.              | Cylinder low Reg.   |
| 0    | 1    | 1    | 0    | 1    | Cylinder high Reg.             | Cylinder high Reg.  |
| 0    | 1    | 1    | 1    | 0    | Drive/Head Reg.                | Drive/Head Reg.     |
| 0    | 1    | 1    | 1    | 1    | Status Reg.                    | Command Reg.        |
|      |      |      |      |      | <b>Control Block Registers</b> |                     |
| 1    | 0    | 1    | 1    | 0    | Alt. Status Reg.               | Device control Reg. |
| 1    | 0    | 1    | 1    | 1    | Drive address Reg.             | –                   |

Figure 49. I/O address map

This page intentionally left blank.

---

## Part 2. Interface specification

This page intentionally left blank.

---

## 8.0 General

---

### 8.1 Introduction

This specification describes the host interface of the Hitachi Travelstar 60GH & 40GN.

The interface conforms to the Working Document of Information technology, AT Attachment with Packet Interface Extension (ATA/ATAPI-5) Revision 3, dated 29 February 2000, with certain limitations described in section 9.0, "Deviations From Standard" on page 65.

The drive supports the following new functions included by ATA/ATAPI-5 standards or newer standards:

- Device Configuration Overlay

The drive supports the following functions as Vendor Specific Functions:

- Address Offset Feature
- Format Unit Function
- ENABLE/DISABLE DELAYED WRITE
- SENSE CONDITION command

---

### 8.2 Terminology

|                      |  |
|----------------------|--|
| <b>Device</b>        | The Hitachi Travelstar 60GH & 40GN drive   |
| <b>Host</b>          | The system to which the device is attached   |
| <b>First Command</b> | The first command which is executed after the power on reset (also known as a hard reset) is the Standby mode command. |
| <b>INTRQ</b>         | Interrupt request (Device or Host)   |

This page intentionally left blank.

---

## 9.0 Deviations from standard

The device conforms to the referenced specifications, with deviations described below.

The interface conforms to the Working Document of Information Technology, AT Attachment with Packet Interface Extension (ATA/ATAPI-5) Revision 3, dated 29 February 2000, with the following deviation:

|                                 |   |
|---------------------------------|---|
| <b>Standby Timer</b>            | Standby timer is enabled by STANDBY command or IDLE command. The value in the Sector Count register shall be used to determine the time programmed into the Standby timer. If the Sector Count register is zero, the Standby timer is automatically set to 109 minutes.   |
| <b>Write Verify</b>             | WRITE VERIFY command does not include read verification after write operation. The function is the same as WRITE SECTORS command.   |
| <b>S.M.A.R.T. Return Status</b> | S.M.A.R.T. RETURN STATUS subcommand does not check advisory attributes. This means that the device will not report a threshold exceeded condition unless the prefailure attributes exceed their corresponding thresholds. For example, a Power-On Hours Attribute never results in a negative reliability status. |

This page intentionally left blank.

## 10.0 Registers

| Addresses               |      |     |     |     | Functions               |                  |
|-------------------------|------|-----|-----|-----|-------------------------|------------------|
| CS0-                    | CS1- | DA2 | DA1 | DA0 | READ (DIOR-)            | WRITE (DIOW-)    |
| N                       | N    | x   | x   | x   | Data bus high impedance | Not used         |
| Control block registers |      |     |     |     |                         |                  |
| N                       | A    | 0   | x   | x   | Data bus high impedance | Not used         |
| N                       | A    | 1   | 0   | x   | Data bus high impedance | Not used         |
| N                       | A    | 1   | 1   | 0   | Alternate Status        | Device Control   |
| N                       | A    | 1   | 1   | 1   | Device Address          | Not used         |
| Command block registers |      |     |     |     |                         |                  |
| A                       | N    | 0   | 0   | 0   | Data                    | Data             |
| A                       | N    | 0   | 0   | 1   | Error Register          | Features         |
| A                       | N    | 0   | 1   | 0   | Sector Count            | Sector Count     |
| A                       | N    | 0   | 1   | 1   | Sector Number           | Sector Number    |
| A                       | N    | 0   | 1   | 1   | * LBA bits 0-7          | * LBA bits 0-7   |
| A                       | N    | 1   | 0   | 0   | Cylinder Low            | Cylinder Low     |
| A                       | N    | 1   | 0   | 0   | * LBA bits 8-15         | * LBA bits 8-15  |
| A                       | N    | 1   | 0   | 1   | Cylinder High           | Cylinder High    |
| A                       | N    | 1   | 0   | 1   | * LBA bits 16-23        | * LBA bits 16-23 |
| A                       | N    | 1   | 1   | 0   | Device/Head.            | Device/Head      |
| A                       | N    | 1   | 1   | 0   | * LBA bits 24-27        | * LBA bits 24-27 |
| A                       | N    | 1   | 1   | 1   | Status                  | Command          |
| A                       | A    | x   | x   | x   | Invalid address         | Invalid address  |

Logic conventions:    A = signal asserted  
                               N = signal not asserted  
                               x = either A or N

\* = Mapping of registers in LBA mode

Figure 50. Register Set

Communication to or from the device is through an I/O Register that routes the input or output data to or from the registers addressed by the signals from the host (CS0-, CS1-, DA2, DA1, DA0, DIOR- and DIOW-).

The Command Block Registers are used for sending commands to the device or posting status from the device.

The Control Block Registers are used for device control and to post alternate status.

---

## 10.1 Alternate Status Register

---

| Alternate Status Register |     |    |     |     |     |     |     |
|---------------------------|-----|----|-----|-----|-----|-----|-----|
| 7                         | 6   | 5  | 4   | 3   | 2   | 1   | 0   |
| BSY                       | RDY | DF | DSC | DRQ | COR | IDX | ERR |

---

Figure 51. Alternate Status Register

This register contains the same information as the Status Register. The only difference between this register and the Status Register is that reading the Alternate Status Register does not imply an interrupt acknowledge or a clear of a pending interrupt. See 10.13, "Status Register" on page 72 for the definition of the bits in this register.

---

## 10.2 Command Register

This register contains the command code being sent to the device. Command execution begins immediately after this register is written. The command set is shown in Figure 72 on page 107. All other registers required for the command must be set up before writing to the Command Register.

---

## 10.3 Cylinder High Register

This register contains the high order bits of the starting cylinder address for any disk access. At the end of the command, this register is updated to reflect the current cylinder number.

In LBA Mode this register contains Bits 16–23. At the end of the command, this register is updated to reflect the current LBA Bits 16–23.

The cylinder number may be from zero to the number of cylinders minus one.

---

## 10.4 Cylinder Low Register

This register contains the low order 8 bits of the starting cylinder address for any disk access. At the end of the command, this register is updated to reflect the current cylinder number.

In LBA Mode this register contains Bits 8–15. At the end of the command, this register is updated to reflect the current LBA Bits 8–15.

The cylinder number may be from zero to the number of cylinders minus one (1).

---

## 10.5 Data Register

This register is used to transfer data blocks between the device data buffer and the host. It is also the register through which sector information is transferred on a Format Track command and the configuration information is transferred on an Identify Device command.

All data transfers are 16 bits wide, except for ECC byte transfers, which are 8 bits wide. Data transfers are PIO only.

The register contains valid data only when DRQ = 1 is in the Status Register.

---

## 10.6 Device Control Register

---

| Drive Control Register |   |   |   |   |      |      |   |
|------------------------|---|---|---|---|------|------|---|
| 7                      | 6 | 5 | 4 | 3 | 2    | 1    | 0 |
| -                      | - | - | - | 1 | SRST | -IEN | 0 |

---

Figure 52. Device Control Register

| Bit         | Definitions   |
|-------------|---|
| <b>SRST</b> | Software Reset. The device is held at reset when RST = 1. Setting RST = 0 again enables the device. To ensure that the device recognizes the reset, the host must set RST = 1 and wait for at least 5 $\mu$ s before setting RST = 0. |
| <b>-IEN</b> | Interrupt Enable. When IEN = 0, and the device is selected, the device interrupts to the host will be enabled. When IEN = 1, or the device is not selected, the device interrupts to the host will be disabled.                       |

---

## 10.7 Drive Address Register

---

| Drive Address Register |      |     |     |     |     |      |      |
|------------------------|------|-----|-----|-----|-----|------|------|
| 7                      | 6    | 5   | 4   | 3   | 2   | 1    | 0    |
| HIZ                    | -WTG | -H3 | -H2 | -H1 | -H0 | -DS1 | -DS0 |

---

Figure 53. Drive Address Register

This register contains the inverted drive select and head select addresses of the currently selected drive.

### Bit Definitions

- HIZ** High Impedance. This bit is not a device and will always be in a high impedance state.
- WTG** -Write Gate. This bit is 0 when writing to the disk device is in progress.
- H3, -H2, -H1, -H0** -Head Select. These four bits are the one's complement of the binary coded address of the currently selected head. Bit -H0 is the least significant.
- DS1** -Drive Select 1. The Drive Select bit for device 1 is active low. DS1 = 0 when device 1 (slave) is selected and active.
- DS0** -Drive Select 0. The Drive Select bit for device 0 is active low. DS0 = 0 when device 0 (master) is selected and active.

---

## 10.8 Device/Head Register

---

| Device/Head Register |   |   |     |     |     |     |     |
|----------------------|---|---|-----|-----|-----|-----|-----|
| 7                    | 6 | 5 | 4   | 3   | 2   | 1   | 0   |
| 1                    | L | 1 | DRV | HS3 | HS2 | HS1 | HS0 |

---

Figure 54. Device/Head Register

This register contains the device and head numbers.

### Bit Definitions

- L** Binary encoded address mode select. When L = 0, addressing is by CHS mode. When L = 1, addressing is by LBA mode.
- DRV** Device. When DRV = 0, device 0 (master) is selected. When DRV = 1, device 1 (Slave) is selected.
- HS3, HS2, HS0** Head Select. These four bits indicate the binary encoded address of the head. Bit HS0 is the least significant bit. At command completion, these bits are updated to reflect the currently selected head. The head number may be from zero to the number of heads minus one. In LBA mode, HS3 through HS0 contain bits 24–27 of the LBA. At command completion, these bits are updated to reflect the current LBA bits 24–27.

---

## 10.9 Error Register

---

| Error Register |     |   |      |   |      |       |      |
|----------------|-----|---|------|---|------|-------|------|
| 7              | 6   | 5 | 4    | 3 | 2    | 1     | 0    |
| CRC            | UNC | 0 | IDNF | 0 | ABRT | TKONF | AMNF |

---

Figure 55. Error Register

This register contains the status from the last command executed by the device or a diagnostic code. At the completion of any command, except Execute Device Diagnostic, the contents of this register are always valid even if ERR = 0 is in the Status Register.

Following a power on, a reset, or completion of an Execute Device Diagnostic command, this register contains a diagnostic code. See Figure 59 on page 75 for the definitions.

### Bit Definitions

- ICRCE (CRC)** Interface CRC Error. When CRC = 1, it indicates that a CRC error has occurred on the data bus during a Ultra DMA transfer.
- UNC** Uncorrectable Data Error. When UNC = 1 it indicates that an uncorrectable data error has been encountered.
- IDNF (IDN)** ID Not Found. When IDN = 1, it indicates that the requested sector's ID field could not be found.
- ABRT (ABT)** Aborted Command. When ABT = 1, it indicates that the requested command has been aborted due to a device status error or an invalid parameter in an output register.
- TKONF (TON)** Track 0 Not Found. When TON = 1, it indicates that track 0 was not found during a Recalibrate command.
- AMNF (AMN)** Address Mark Not Found. When AMN = 1, it indicates that the data address mark has not been found after finding the correct ID field for the requested sector.

---

## 10.10 Features Register

This register is command specific. This register is used with the Set Features command, the S.M.A.R.T. Function Set command, and the Format Unit command.

---

## 10.11 Sector Count Register

This register contains the number of sectors of data requested to be transferred on a read or write operation between the host and the device. If the value in the register is set to 0, a count of 256 sectors is specified.

If the register is zero at command completion, the command was successful. If it is not successfully completed, the register contains the number of sectors which need to be transferred in order to complete the request.

The contents of the register are defined differently on some commands. These definitions are given in section 13.0, "Command descriptions" on 107.

---

## 10.12 Sector Number Register

This register contains the starting sector number for any disk data access for the subsequent command. The sector number is from one to the maximum number of sectors per track.

In LBA mode, this register contains Bits 0–7. At the end of the command, this register is updated to reflect the current LBA Bits 0–7.

---

## 10.13 Status Register

---

| Status Register |      |    |     |     |     |     |     |
|-----------------|------|----|-----|-----|-----|-----|-----|
| 7               | 6    | 5  | 4   | 3   | 2   | 1   | 0   |
| BSY             | DRDY | DF | DSC | DRQ | COR | IDX | ERR |

---

Figure 56. Status Register

This register contains the device status. The contents of this register are updated whenever an error occurs and at the completion of each command.

If the host reads this register when an interrupt is pending, it is considered to be the interrupt acknowledge. Any pending interrupt is cleared whenever this register is read.

If BSY=1, no other bits in the register are valid.

### Bit Definitions

|                   |   |
|-------------------|---|
| <b>BSY</b>        | Busy. Bit BSY=1 whenever the device is accessing the registers. The host should not read or write any registers when BSY=1. If the host reads any register when BSY=1, the contents of the Status Register will be returned.  |
| <b>DRDY (RDY)</b> | Device Ready. When bit RDY=1 it indicates that the device is capable of responding to a command. Bit RDY will be set to 0 during power on until the device is ready to accept a command.  |
| <b>DF</b>         | Device Fault. If DF=1 it indicates that the device has detected a write fault condition. Bit DF is set to 0 after the Status Register is read by the host.  |
| <b>DSC</b>        | Device Seek Complete. If DSC=1, it indicates that a Seek has completed and the device head is settled over a track. Bit DSC is set to 0 by the device just before a Seek begins. When an error occurs, this bit is not changed until the Status Register is read by the host and at that time the bit again indicates the current Seek complete status. When the device enters into or is in Standby mode or Sleep mode, this bit is set by device in spite of the drive not spinning up. |
| <b>DRQ</b>        | Data Request. Bit DRQ=1 indicates that the device is ready to transfer a word or byte of data between the host and the device. The host should not write the Command register when DRQ=1.   |
| <b>CORR (COR)</b> | Corrected Data. Always 0.   |
| <b>IDX</b>        | Index. Bit IDX=1 once per revolution. Since IDX=1, only for a very short time during each revolution, the host may not see it set to 1 even if the host is reading the Status Register continuously. Therefore the host should not attempt to use IDX bit for timing purposes.  |
| <b>ERR</b>        | Error. Bit ERR=1 indicates that an error occurred during execution of the previous command. The Error Register should be read to determine the error type. The device sets bit ERR=0 when the next command is received from the host.   |

---

## 11.0 General operation descriptions

---

### 11.1 Reset response

ATA has the following three types of resets:

- Power On Reset (POR)** The device executes a series of electrical circuitry diagnostics, spins up the head disk assembly, tests speed and other mechanical parametric, and sets default values.
- Hard Reset (Hardware Reset)** The RESET signal is negated in the ATA Bus. The device resets the interface circuitry and sets the default values.
- Soft Reset (Software Reset)** The SRST bit in the Device Control Register is set and then is reset. The device resets the interface circuitry according to the Set Features requirement.

The actions of each reset are shown in Figure 57 on page 74.

|   | POR  | hard<br>reset | soft<br>reset |
|---|------|---------------|---------------|
| Aborting Host interface   | -    | o             | o             |
| Aborting Device operation   | -    | (*1)          | (*1)          |
| Initialization of hardware  | o    | x             | x             |
| Internal diagnostic   | o    | x             | x             |
| Starting or Spinning Up spindle motor   | (*6) | x             | x             |
| Initialization of registers (*2)  | o    | o             | o             |
| DASP- handshake   | o    | o             | x             |
| PDIAG- handshake  | o    | o             | o             |
| Reverting programmed parameters to default <ul style="list-style-type: none"> <li>• Number of CHS (set by Initialize Device Parameters)</li> <li>• Multiple mode</li> <li>• Write Cache</li> <li>• Delayed Write</li> <li>• Read look-ahead</li> <li>• ECC bytes</li> <li>• Volatile max. Address</li> <li>• Address offset mode</li> </ul> | o    | o             | (*3)          |
| Power mode  | (*6) | (*4)          | (*4)          |
| Reset Standby timer value (*5)  | o    | o             | o             |

o—execute

x—does not execute

**Notes.**

- (\*1). *Execute after the data in write cache has been written.*
- (\*2). *The default value on POR is shown in Figure 58 on page 75.*
- (\*3). *The Set Features command with Feature register = CCh enables the device to revert these parameters to the power on defaults.*
- (\*4). *In the case of sleep mode, the device goes to standby mode. In other cases, the device does not change current mode.*
- (\*5). *After reset the Standby timer value is set to 109 minutes.*
- (\*6). *Set according to the initial power mode selection.*

Figure 57. Reset response table

---

## 11.2 Register initialization

After a power on, a hard reset, or a software reset, the register values are initialized as shown in the table below.

---

| Register         | Default Value   |
|------------------|-----------------|
| Error            | Diagnostic Code |
| Sector Count     | 01h             |
| Sector Number    | 01h             |
| Cylinder Low     | 00h             |
| Cylinder High    | 00h             |
| Device/Head      | A0h             |
| Status           | 50h             |
| Alternate Status | 50h             |

---

Figure 58. Default Register Values

If an Execute Device Diagnostic command is carried out, if the system is powered on, or if a hard reset occurs, the system generates an Error Register diagnostic code. See the table below for a description of the codes.

---

| Code | Description                     |
|------|---------------------------------|
| 01h  | No error detected               |
| 02h  | Formatter device error          |
| 03h  | Sector buffer error             |
| 04h  | ECC circuitry error             |
| 05h  | Controller microprocessor error |
| 8xh  | Device 1 failed                 |

---

Figure 59. Diagnostic Codes

---

## 11.3 Diagnostic and Reset considerations

The Set Max password, the Set Max security mode and the Set Max unlock counter are not retained over a Power On Reset but are retained over a Hard Reset or Soft Reset.

For each Reset and Execute Device Diagnostic, the diagnostic is done as follows:

|                                   |  |
|-----------------------------------|--|
| <b>Power On Reset, Hard Reset</b> | DASP- is read by Device 0 to determine if Device 1 is present. If Device 1 is present Device 0 shall read PDIAG- to determine when it is valid to clear the BSY bit and whether Device 1 has powered on or reset without error, otherwise Device 0 clears the BSY bit whenever it is ready to accept commands. Device 0 may assert DASP- to indicate device activity. If Device 1 is not present, Device 0 does not Assert DASP- at POR. |
| <b>Soft Reset</b>                 | If Device 1 is present, Device 0 shall read PDIAG- to determine when it is valid to clear the BSY bit and whether Device 1 has reset without any errors; otherwise, Device 0 shall simply reset and clear the BSY bit. DASP- is asserted by Device 0 (and Device 1 if it is present) in order to indicate device active.   |
| <b>Execute Device Diagnostic</b>  | If Device 1 is present, Device 0 shall read PDIAG- to determine when it is valid to clear the BSY bit and if Device 1 passed or failed the EXECUTE DEVICE DIAGNOSTIC command; otherwise, Device 0 shall simply execute its diagnostics and then clear the BSY bit. DASP- is asserted by Device 0 (and Device 1 if it is present) in order to indicate that the device is active.   |

In each case – **Power On Reset [Hard Reset]**, **Soft Reset**, and the **Execute Device Diagnostic** command – the Device 0 Error register value is interpreted using the table below.

---

| Device 1 present? | PDIAG- Asserted? | Device 0 Passed | Error Register |
|-------------------|------------------|-----------------|----------------|
| Yes               | Yes              | Yes             | 01h            |
| Yes               | Yes              | No              | 0xh            |
| Yes               | No               | Yes             | 81h            |
| Yes               | No               | No              | 8xh            |
| No                | (not read)       | Yes             | 01h            |
| No                | (not read)       | No              | 0xh            |

The "x" indicates the appropriate Diagnostic Code for the Power on, RESET-, Soft Reset, or Device Diagnostic error.

---

Figure 60. Reset error register values

---

## 11.4 Power-off considerations

### 11.4.1 Load/Unload

Load/Unload is a functional mechanism of the hard disk drive. It is controlled by the drive microcode. Specifically, unloading of the heads is invoked by the following commands.

---

| Command           | Response    |
|-------------------|-------------|
| Standby           | UL -> Comp. |
| Standby Immediate | UL -> Comp. |
| Sleep             | UL -> Comp. |

| Reset      | Response  |
|------------|-----------|
| Soft Reset | Rdy (*1)  |
| Hard Reset | UL -> Rdy |

UL = unload  
Comp = complete  
Rdy = interface ready  
(\*1) Load/Unload condition is not changed by Soft Reset

---

Figure 61. Device behavior by ATA commands.

Load/unload is also invoked as one of the idle modes of the drive.

The specified start/stop life of the product assumes that load/unload is operated normally, NOT in emergency mode.

### 11.4.2 Emergency unload

When the drive power is interrupted with the heads still loaded, the microcode cannot operate and the normal 5V power is unavailable to unload the heads. In this case, normal unload is not possible, so the heads are unloaded by routing the back EMF of the spinning motor to the voice coil. The actuator velocity is greater than the normal case, and the unload process is inherently less controllable without a normal seek current profile.

Emergency unload is intended to be invoked in rare situations. Because this operation is inherently uncontrolled, it is more mechanically stressful than a normal unload.

A single emergency unload operation is more stressful than 100 normal unloads. Use of emergency unload reduces the start/stop life of the drive at a rate at least 100 times faster than that of normal unload and may damage the drive.

### 11.4.3 Required power-off sequence

When power is removed on most drives at an arbitrary time, problems can result. The following are examples of such problems:

- Data is lost from the write buffer
- If the drive is writing a sector, a partially-written sector with an incorrect ECC block results, the sector contents are destroyed, and reading that sector results in a hard error
- Heads may land in the data zone instead of the landing zone depending on the design of the drive

You may then turn off the drive in the following order:

1. Issue Standby Immediate or sleep command
2. Wait until COMMAND COMPLETE STATUS is returned. (It may take up to 350 ms in a typical case.)
3. Terminate power to drive

This power-down sequence should be followed for entry into any system power-down state, system suspend state, or system hibernation state. In a robustly designed system, emergency unload is limited to rare scenarios such as battery removal during operation.

---

## 11.5 Sector Addressing Mode

All addressing of data sectors recorded on the device's media is done by a logical sector address. The logical CHS address for the drive is different from the actual physical CHS location of the data sector on the disk media.

The drive supports both Logical CHS Addressing Mode and LBA Addressing Mode as the sector addressing mode.

The host system may select either the currently selected CHS translation addressing or LBA addressing on a command-by-command basis by using the L bit in the DEVICE/HEAD register. A host system must set the L bit to 1 if the host uses LBA Addressing mode.

### 11.5.1 Logical CHS addressing mode

The logical CHS addressing is made up of three fields: the cylinder number, the head number, and the sector number. Sectors are numbered from 1 to the maximum value allowed by the current CHS translation mode but cannot exceed 255 (0FFh). Heads are numbered from 0 to the maximum value allowed by the current CHS translation mode but cannot exceed 15 (0Fh). Cylinders are numbered from 0 to the maximum value allowed by the current CHS translation mode but cannot exceed 65535 (0FFFFh).

When the host selects a CHS translation mode using the INITIALIZE DEVICE PARAMETERS command, the host requests the number of sectors per logical track and the number of heads per logical cylinder. The device then computes the number of logical cylinders available in requested mode.

The default CHS translation mode is described in the Identify Device Information. The current CHS translation mode also is described in the Identify Device Information.

## 11.5.2 LBA addressing mode

Logical sectors on the device shall be linearly mapped with the first LBA addressed sector (sector 0) being the same sector as the first logical CHS addressed sector (cylinder 0, head 0, sector 1). Irrespective of the logical CHS translation mode currently in effect, the LBA address of a given logical sector does not change. The following formula is always true:

$$\text{LBA} = ((\text{cylinder} \times \text{heads\_per\_cylinder} + \text{heads}) \times \text{sectors\_per\_track}) + \text{sector} - 1$$

where `heads_per_cylinder` and `sectors_per_track` are the current translation mode values.

On LBA addressing mode, the LBA value is set to the following register:

|               |                       |
|---------------|-----------------------|
| Device/Head   | <- - - LBA bits 27–24 |
| Cylinder High | <- - - LBA bits 23–16 |
| Cylinder Low  | <- - - LBA bits 15–8  |
| Sector Number | <- - - LBA bits 7–0   |

---

## 11.6 Power management features

The power management feature set permits a host to modify the behavior in a manner which reduces the power required to operate. The power management feature set provides a set of commands and a timer that enables a device to implement low power consumption modes.

The drive implements the following set of functions:

1. A Standby timer
2. Idle command
3. Idle Immediate command
4. Sleep command
5. Standby command
6. Standby Immediate command

### 11.6.1 Power Mode

|                     |  |
|---------------------|--|
| <b>Sleep Mode</b>   | The lowest power consumption when the device is powered on occurs in Sleep Mode. When in sleep mode, the device requires a reset to be activated.                                      |
| <b>Standby Mode</b> | The device interface is capable of accepting commands, but since the media may not be immediately accessible, there is a delay while waiting for the spindle to reach operating speed. |
| <b>Idle Mode</b>    | Refer to 11.7, "Adaptive Battery Life Extender (ABLE-3) feature" on page 82.   |
| <b>Active Mode</b>  | The device is in execution of a command or accessing the disk media with the read look-ahead function or the write cache function.   |

### 11.6.2 Power management commands

The Check Power Mode command allows a host to determine if a device is currently in, going to, or leaving standby mode.

The Idle and Idle Immediate commands move a device to idle mode immediately from the active or standby modes. The idle command also sets the standby timer count and starts the standby timer.

The sleep command moves a device to sleep mode. The device's interface becomes inactive at the completion of the sleep command. A reset is required to move a device out of sleep mode. When a device exits sleep mode it will enter standby mode.

The Standby and Standby Immediate commands move a device to standby mode immediately from the active or idle modes. The standby command also sets the standby timer count.

### 11.6.3 Standby/Sleep command completion timing

1. Confirm the completion of writing cached data in the buffer to media.
2. Unload the heads on the ramp.
3. Set the DRDY bit and the DSC bit in Status Register.
4. Set the INTRQ (completion of the command).
5. Activate the spindle break to stop the spindle motor.
6. Wait until the spindle motor is stopped.
7. Perform the post process.

## 11.6.4 Standby timer

The standby timer provides a method for the device to automatically enter standby mode from either active or idle mode following a host programmed period of inactivity. If the device is in the active or idle mode, the device waits for the specified time period and if no command is received, the device automatically enters the standby mode.

If the value of the SECTOR COUNT register on Idle command or the Standby command is set to "00h", the device will automatically set the standby timer to 109 minutes.

## 11.6.5 Status

In the active, idle, and standby modes, the device shall have the RDY bit of the status register set. If the BSY bit is not set, the device shall be ready to accept any command.

In sleep mode, the device's interface is not active. A host shall not attempt to read the status of the device or issue commands to the device.

## 11.6.6 Interface Capability for Power Modes

Each power mode affects the physical interface as defined in the following table:

---

| Mode    | BSY | RDY | Interface active | Media    |
|---------|-----|-----|------------------|----------|
| Active  | x   | x   | Yes              | Active   |
| Idle    | o   | 1   | Yes              | Active   |
| Standby | o   | 1   | Yes              | Inactive |
| Sleep   | x   | x   | No               | Inactive |

---

Figure 62. Power conditions

Ready (RDY) is not a power condition. A device may post ready at the interface even though the media may not be accessible.

The interface is inactive in sleep mode, but the access to the interface registers and the validity of INTRQ is guaranteed for two seconds after the Sleep command is completed. After this period, the contents of interface registers may be lost. Since the contents of interface registers may be invalid, the host should NOT check the Status register nor the Alternate Status register prior to issuing a soft reset to wake up a device.

## 11.6.7 Initial Power Mode at Power On

After power on or hard reset the device goes to IDLE mode or STANDBY mode depending on the option. Refer to section 4.4.3, "Operating Modes" on page 17 for the initial power mode selection.

---

## 11.7 Advanced Power Management (ABLE-3) feature

This feature provides power saving without performance degradation. The Adaptive Battery Life Extender 3 (ABLE-3) technology intelligently manages transition among power modes within the device by monitoring access patterns of the host.

This technology has three idle modes; Performance Idle mode, Active Idle mode, and Low Power Idle mode.

This feature allows the host to select an advanced power management level. The advanced power management level is a scale from the lowest power consumption setting of 01h to the maximum performance level of FEh. Device performance may increase with increasing advanced power management levels. Device power consumption may increase with increasing advanced power management levels. The advanced power management levels contain discrete bands, described in the section of Set Feature command in detail.

This feature set uses the following functions:

- A SET FEATURES subcommand to enable Advanced Power Management
- A SET FEATURES subcommand to disable Advanced Power Management

The Advanced Power Management feature is independent of the Standby timer setting. If both Advanced Power Management level and the Standby timer are set, the device will go to the Standby state when the timer times out or the device's Advanced Power Management algorithm indicates that it is time to enter the Standby state.

The IDENTIFY DEVICE response word 83, bit 3 indicates that Advanced Power Management feature is supported if set. Word 86, bit 3 indicates that Advanced Power Management is enabled if set. Word 91, bits 7-0 contain the current Advanced Power Management level if Advanced Power Management is enabled.

### 11.7.1 Performance Idle Mode

This mode is usually entered immediately after Active mode command processing is complete, instead of conventional idle mode. In Performance Idle mode, all electronic components remain powered and full frequency servo remains operational. This provides instantaneous response to the next command. The duration of this mode is intelligently managed as described below.

### 11.7.2 Active Idle Mode

In this mode, power consumption is 45–55% less than that of Performance Idle mode. Additional electronics are powered off and the head is parked near the mid-diameter of the disk without servoing. Recovery time to Active mode is about 20 ms.

### 11.7.3 Low Power Idle Mode

Power consumption is 60–65% less than that of Performance Idle mode. The heads are unloaded on the ramp but the spindle is still rotated at the full speed. Recovery time to Active mode is about 300 ms.

### 11.7.4 Transition Time

The transition time is dynamically managed by the user's recent access pattern, instead of fixed times. The ABLE-3 algorithm monitors the interval between commands instead of the command frequency of ABLE-2. The algorithm supposes that the next command will come with the same command interval

distribution as the previous access pattern. The algorithm calculates the expected average saving energy and response delay for next command in several transition time case based on this assumption. And it selects the most effective transition time with the condition that the calculated response delay is shorter than the value calculated from the specified level by Set Feature Enable Advanced Power Management command.

The optimal time to enter Active Idle mode is variable depending on the recent behavior of the user. It is not possible to achieve the same level of Power savings with a fixed entry time into Active Idle because every user's data and access pattern is different. The optimum entry time changes over time.

The same algorithm works for entering into Low Power Idle mode and Standby mode, which consumes less power but needs more recovery time switching from this mode to Active mode.

---

## 11.8 S.M.A.R.T. Function

The intent of Self-monitoring, analysis, and reporting technology (S.M.A.R.T.) is to protect user data and prevent unscheduled system downtime that may be caused by predictable degradation and/or fault of the device. By monitoring and storing critical performance and calibration parameters, S.M.A.R.T. devices employ sophisticated data analysis algorithms to predict the likelihood of near-term degradation or fault condition. By alerting the host system of a negative reliability status condition, the host system can warn the user of the impending risk of a data loss and advise the user of appropriate action.

Since S.M.A.R.T. utilizes the internal device microprocessor and other device resources, there may be some small overhead associated with its operation. However, special care has been taken in the design of the S.M.A.R.T. algorithms to minimize the impact to host system performance. Actual impact of S.M.A.R.T. overhead is dependent on the specific device design and the usage patterns of the host system. To further ensure minimal impact to the user, S.M.A.R.T. capable devices are shipped from the device manufacturer's factory with the S.M.A.R.T. feature disabled. S.M.A.R.T. capable devices can be enabled by the system OEMs at time of system integration or in the field by after-market products.

### 11.8.1 Attributes

Attributes are the specific performance or calibration parameters that are used in analyzing the status of the device. Attributes are selected by the device manufacturer based on that attribute's ability to contribute to the prediction of degrading or faulty conditions for that particular device. The specific set of attributes being used and the identity of these attributes is vendor specific and proprietary.

### 11.8.2 Attribute values

Attribute values are used to represent the relative reliability of individual performance or calibration attributes. Higher attribute values indicate that the analysis algorithms being used by the device are predicting a lower probability of a degrading or fault condition existing. Accordingly, lower attribute values indicate that the analysis algorithms being used by the device are predicting a higher probability of a degrading or fault condition existing. There is no implied linear reliability relationship corresponding to the numerical relationship between different attribute values for any particular attribute.

### 11.8.3 Attribute thresholds

Each attribute value has a corresponding attribute threshold limit which is used for direct comparison to the attribute value to indicate the existence of a degrading or faulty condition. The numerical value of the attribute thresholds are determined by the device manufacturer through design and reliability testing and analysis. Each attribute threshold represents the lowest limit to which its corresponding attribute value can be equal while still retaining a positive reliability status. Attribute thresholds are set at the device manufacturer's factory and cannot be changed in the field. The valid range for attribute thresholds is from 1 through 253 decimal.

### 11.8.4 Threshold exceeded condition

If one or more attribute values are less than or equal to their corresponding attribute thresholds, then the device reliability status is negative, indicating an impending degrading or faulty condition.

### 11.8.5 S.M.A.R.T. commands

The S.M.A.R.T. commands provide access to attribute values, attribute thresholds and other logging and reporting information.

### **11.8.6 S.M.A.R.T. operation with power management modes**

The device saves attribute values automatically on every head unload timing except the emergency unload, even if the attribute auto save feature is not enabled. The head unload is done not only by Standby, Standby Immediate, or Sleep command or Hard Reset, but also by the automatic power saving functions like ABLE-3 or Standby timer. So basically it is not necessary for a host system to enable the attribute auto save feature, when it utilizes the power management. If the attribute auto save feature is enabled, attribute values will be saved after 30minutes passed since the last saving, besides above condition.

---

## 11.9 Security Mode Feature Set

Security Mode Feature Set is a powerful security feature. With a device lock password, a user can prevent unauthorized access to a device even if it is removed from the computer.

New commands are supported for this feature as listed below:

|                                  |         |
|----------------------------------|---------|
| <b>Security Set Password</b>     | ('F1'h) |
| <b>Security Unlock</b>           | ('F2'h) |
| <b>Security Erase Prepare</b>    | ('F3'h) |
| <b>Security Erase Unit</b>       | ('F4'h) |
| <b>Security Freeze Lock</b>      | ('F5'h) |
| <b>Security Disable Password</b> | ('F6'h) |

### 11.9.1 Security Mode

The following security modes are provided.

|                             |  |
|-----------------------------|--|
| <b>Device Locked Mode</b>   | The device disables media access commands after power on. Media access commands are enabled by either a Security Unlock command or a Security Erase Unit command.  |
| <b>Device Unlocked Mode</b> | The device enables all commands. If a password is not set this mode is entered after power on, otherwise it is entered by a Security Unlock or a Security Erase Unit command.  |
| <b>Device Frozen Mode</b>   | The device enables all commands except those which can update the device lock function, set/change password. The device enters this mode via a Security Freeze Lock command. It cannot quit this mode until power off. |

### 11.9.2 Security level

The following security levels are provided:

|                               |  |
|-------------------------------|--|
| <b>High level security</b>    | When the device lock function is enabled and the User Password is forgotten, the device can be unlocked via a Master Password.   |
| <b>Maximum level security</b> | When the device lock function is enabled and the User Password is forgotten, then only the Master Password with a Security Erase Unit command can unlock the device. Then user data is erased. |

### 11.9.3 Password

This function can have two types of passwords as described below.

|                        |  |
|------------------------|--|
| <b>Master Password</b> | When the Master Password is set, the device does NOT enable the Device Lock Function, and the device CANNOT be locked with the Master Password, but the Master Password can be used for unlocking the locked device. |
| <b>User Password</b>   | The User Password should be given or changed by a system user. When the User Password is set, the device enables the Device Lock Function, and then the device is locked on the next power on reset or hard reset.   |

The system manufacturer or dealer who intends to enable the device lock function for end users must set the master password even if only single level password protection is required. Otherwise, the 'default' master password which is set by Hitachi can unlock a device that is locked with a user password.

## 11.9.4 Master Password Revision Code

This Master Password Revision Code is set by Security Set Password command with the master password. And this revision code field is returned in the Identify Device command word 92. The valid revision codes are 0001h to FFFEh. The default value of Master Password Revision Code is FFFEh. Values 0000h and FFFFh are reserved.

## 11.9.5 Operation example

### 11.9.5.1 Master Password setting

The system manufacturer or dealer can set an initial Master Password using the Security Set Password command, without enabling the Device Lock Function.

### 11.9.5.2 User Password setting

When a User Password is set, the device will automatically enter lock mode the next time the device is powered on.

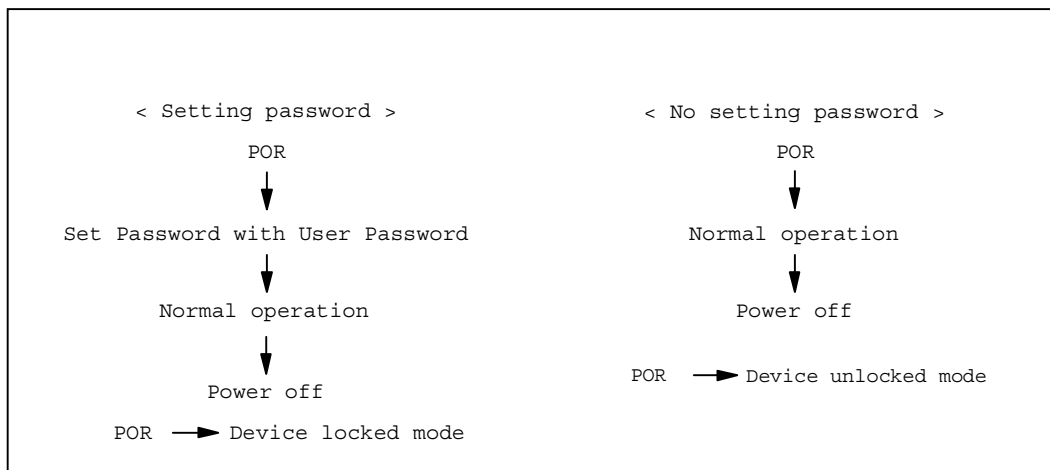
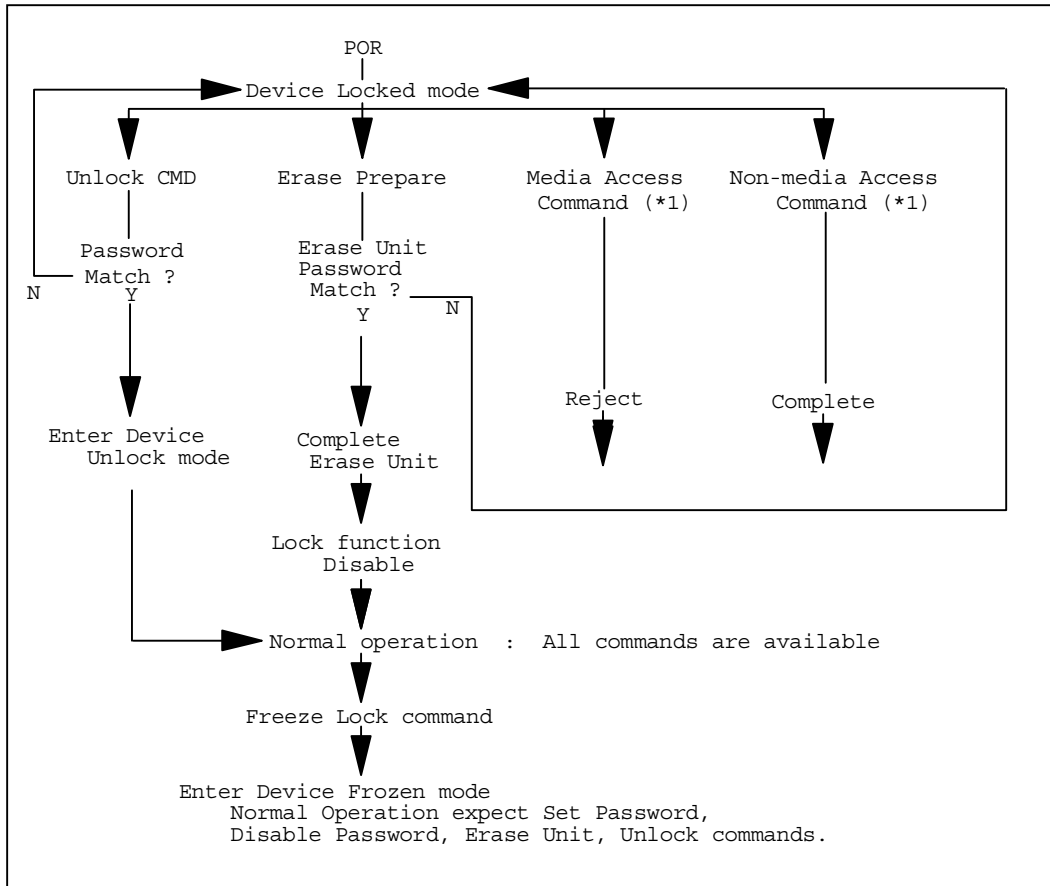

Figure 63. Initial setting

### 11.9.5.3 Operation from POR after user password is set

When Device Lock Function is enabled, the device rejects media access command until a Security Unlock command is successfully completed.



(\*1) — refers to the commands in Figure 66, "Command table for device lock operation" on 90 and 91.

Figure 64. Usual operation for POR

### 11.9.5.4 User Password lost

If the User Password is forgotten and High level security is set, the system user cannot access any data. However the device can be unlocked using the Master Password.

If a system user forgets the User Password and Maximum security level is set, data access is impossible. However the device can be unlocked using the Security Erase Unit command to unlock the device and erase all user data with the Master Password.

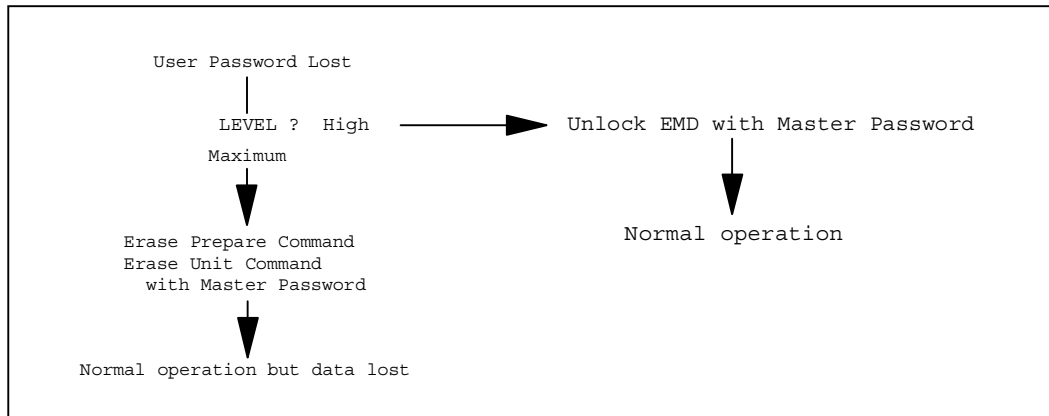

Figure 65. Password lost

### 11.9.5.5 Attempt limit for the SECURITY UNLOCK command

The SECURITY UNLOCK command has an attempt limit the purpose of which is to prevent someone from attempting to unlock the drive with various passwords numerous times.

The device counts the password mismatch. If the password does not match, the device counts it without distinguishing the Master password and the User password. If the count reaches 5, EXPIRE bit (bit 4) of Word 128 in Identify Device information is set, and then the SECURITY ERASE UNIT command and the SECURITY UNLOCK command are aborted until a hard reset or a power off. The count and EXPIRE bit are cleared after a power on reset or a hard reset.

## 11.9.6 Command table

This table shows the device's response to commands when the Security Mode Feature Set (Device lock function) is enabled.

| Command                          | Device Locked Mode | Device Unlocked Mode | Device Frozen Mode |
|----------------------------------|--------------------|----------------------|--------------------|
| Check Power Mode                 | o                  | o                    | o                  |
| Enable/Disable Delayed Write     | o                  | o                    | o                  |
| Device Configuration RESTORE     | x                  | o                    | o                  |
| Device Configuration FREEZE LOCK | o                  | o                    | o                  |
| Device Configuration IDENTIFY    | o                  | o                    | o                  |
| Device Configuration SET         | x                  | o                    | o                  |
| Execute Device Diagnostic        | o                  | o                    | o                  |
| Flush Cache                      | o                  | o                    | o                  |
| Format Track                     | x                  | o                    | o                  |
| Format Unit                      | x                  | o                    | o                  |
| Identify Device                  | o                  | o                    | o                  |
| Idle                             | o                  | o                    | o                  |
| Idle Immediate                   | o                  | o                    | o                  |
| Initialize Device Parameters     | o                  | o                    | o                  |
| Read Buffer                      | o                  | o                    | o                  |
| Read DMA                         | x                  | o                    | o                  |
| Read Long                        | x                  | o                    | o                  |
| Read Multiple                    | x                  | o                    | o                  |
| Read Native Max ADDRESS          | o                  | o                    | o                  |
| Read Sector(s)                   | x                  | o                    | o                  |
| Read Verify Sector(s)            | x                  | o                    | o                  |
| Recalibrate                      | o                  | o                    | o                  |
| Security Disable Password        | x                  | o                    | x                  |
| Security Erase Prepare           | o                  | o                    | o                  |
| Security Erase Unit              | o                  | o                    | x                  |
| Security Freeze Lock             | x                  | o                    | o                  |
| Security Set Password            | x                  | o                    | x                  |
| Security Unlock                  | o                  | o                    | x                  |
| Seek                             | o                  | o                    | o                  |
| Sense Condition                  | o                  | o                    | o                  |
| Set Features                     | o                  | o                    | o                  |
| Set Max ADDRESS                  | o                  | o                    | o                  |
| Set Max FREEZE LOCK              | o                  | o                    | o                  |
| Set Max LOCK                     | o                  | o                    | o                  |

Figure 66. Command table for device lock operation (1 of 2)

| <b>Command</b>                               | <b>Device Locked Mode</b> | <b>Device Unlocked Mode</b> | <b>Device Frozen Mode</b> |
|--|---------------------------|-----------------------------|---------------------------|
| Set Max SET PASSWORD                         | 0                         | 0                           | 0                         |
| Set Max UNLOCK                               | 0                         | 0                           | 0                         |
| Set Multiple Mode                            | 0                         | 0                           | 0                         |
| Sleep  | 0                         | 0                           | 0                         |
| S.M.A.R.T. Disable Operations                | 0                         | 0                           | 0                         |
| S.M.A.R.T. Enable/Disable automatic off-line | 0                         | 0                           | 0                         |
| S.M.A.R.T. Enable/Disable Attribute Autosave | 0                         | 0                           | 0                         |
| S.M.A.R.T. Enable Operations                 | 0                         | 0                           | 0                         |
| S.M.A.R.T. Execute Off-line Immediate        | 0                         | 0                           | 0                         |
| S.M.A.R.T. Read Attribute Values             | 0                         | 0                           | 0                         |
| S.M.A.R.T. Read Attribute Thresholds         | 0                         | 0                           | 0                         |
| S.M.A.R.T. Read log sector                   | 0                         | 0                           | 0                         |
| S.M.A.R.T. Write log sector                  | 0                         | 0                           | 0                         |
| S.M.A.R.T. Return Status                     | 0                         | 0                           | 0                         |
| S.M.A.R.T. Save Attribute Values             | 0                         | 0                           | 0                         |
| Standby                                      | 0                         | 0                           | 0                         |
| Standby Immediate                            | 0                         | 0                           | 0                         |
| Write Buffer                                 | 0                         | 0                           | 0                         |
| Write DMA                                    | x                         | 0                           | 0                         |
| Write Long                                   | x                         | 0                           | 0                         |
| Write Multiple                               | x                         | 0                           | 0                         |
| Write Sector(s)                              | x                         | 0                           | 0                         |
| Write Verify                                 | x                         | 0                           | 0                         |

Figure 67. Command table for device lock operation (2 of 2)

---

## 11.10 Protected Area Function

Protected Area Function is to provide a "protected area" which cannot be accessed via conventional methods. This protected area is used to contain critical system data such as BIOS or system management information. The contents of the entire system main memory may also be dumped into the protected area to resume after a system power off.

The LBA/CYL changed by the following commands affects the Identify Device Information.

Two commands are defined for this function:

**Read Native Max ADDRESS** ('F8'h)  
**Set Max ADDRESS** ('F9'h)

Four security extension commands are implemented as sub functions of the Set Max ADDRESS:

**Set Max SET PASSWORD**  
**Set Max LOCK**  
**Set Max FREEZE LOCK**  
**Set Max UNLOCK**

### 11.10.1 Example for operation (In LBA Mode)

Assumptions :

For easier understanding the following example uses actual values for LBA, size, etc. Since it is an example, these values will differ.

Device characteristics:

|                                    |                           |
|------------------------------------|---------------------------|
| Capacity (native)                  | 536,870,912 bytes (536MB) |
| Max LBA (native)                   | 1,048,575 (0FFFFFFh)      |
| Required size for protected area   | 8,388,608 bytes           |
| Required blocks for protected area | 16,384 (004000h)          |
| Customer usable device size        | 528,482,304 bytes (528MB) |
| Customer usable sector count       | 1,032,192 (0FC000h)       |
| LBA range for protected area       | 0FC000h to 0FFFFFFh       |

#### 1. Shipping drives from the drive manufacturer

When the drive is shipped from the manufacturer, the device has been tested to have a capacity of 536 MB, flagging the media defects not visible by the system.

#### 2. Preparing drives at system manufacturer

Special utility software is required to define the size of the protected area and to store the data in it. The sequence is:

Issue Read Native Max ADDRESS command to get the real device max of LBA/CYL. Returned value shows that native device Max LBA is 0FFFFFFh regardless of the current setting.

Make the entire device accessible, including the protected area, by setting the device Max LBA as 0FFFFFFh via Set Max ADDRESS command. The option could be either nonvolatile or volatile.

Test the sectors for protected area (LBA > = 0FC000h) if required.

Write information data such as BIOS code within the protected area.

Change maximum LBA using Set Max ADDRESS command to 0FBFFFh with nonvolatile option.

From this point, the protected area cannot be accessed until next Set Max ADDRESS command is issued. Any BIOS, device driver, or application software accesses the drive as if it is a 528 MB device because the device behaves like a 528 MB device.

3. Conventional usage without system software support:

Since the drive works as a 528 MB device, there is no special care required for normal use of this device.

4. Advanced usage using protected area.

The data in the protected area is accessed by the following steps.

1. Issue Read Native Max ADDRESS command to get the real device max LBA/CYL. Returned value shows that native device Max LBA is 0FFFFFFh regardless of the current setting.
2. Make entire device accessible, including the protected area, by setting device Max LBA as 0FFFFFFh via Set Max ADDRESS command with the volatile option. By using this option, unexpected power removal or reset will prevent the protected area from remaining accessible.
3. Read information data from protected area.
4. Issue hard reset or POR to inhibit any access to the protected area.

## 11.10.2 Set Max security extension commands

The Set Max SET PASSWORD command allows the host to define the password to be used during the current power on cycle. This password is not related to the password used for the Security Mode Feature set. When the password is set, the device is in the Set Max Unlocked mode.

This command requests a transfer of a single sector of data from the host. The following figure defines the content of this sector of information. The password is retained by the device until the next power cycle. When the device accepts this command, the device is in Set Max Unlocked mode.

---

| Word   | Content             |
|--------|---------------------|
| 0      | Reserved            |
| 1-16   | Password (32 bytes) |
| 17-255 | Reserved            |

---

Figure 68. Set Max SET PASSWORD data content

The Set Max LOCK command allows the host to disable the Set Max commands (except Set Max UNLOCK and Set Max FREEZE LOCK) until the next power cycle or the issuance and acceptance of the Set Max UNLOCK command. When this command is accepted, the device is in the Set Max Locked mode.

The Set Max UNLOCK command changes the device from the Set Max Locked mode to the Set Max Unlocked mode.

This command requests a transfer of a single sector of data from the host. The figure shown above defines the content of this sector of information. The password supplied in the sector of data transferred is compared with the stored Set Max password. If the password compare fails, then the device returns command aborted and decrements the unlock counter. On the acceptance of the Set Max LOCK command, this counter is set to a value of five and is decremented for each password mismatch when Set

Max UNLOCK is issued and the device is locked. When this counter reaches zero, then the Set Max UNLOCK command returns command aborted until a power cycle.

The Set Max FREEZE LOCK command allows the host to disable the SET MAX commands (including Set Max UNLOCK) until the next power cycle. When this command is accepted the device is in the Set Max Frozen mode.

The password, the Set Max security mode, and the unlock counter do not persist over a power cycle but persist over a hardware or software reset.

*NOTE: If this command is immediately preceded by a Read Native MAX ADDRESS command, it shall be interpreted as a Set Max ADDRESS command regardless of Feature register value.*

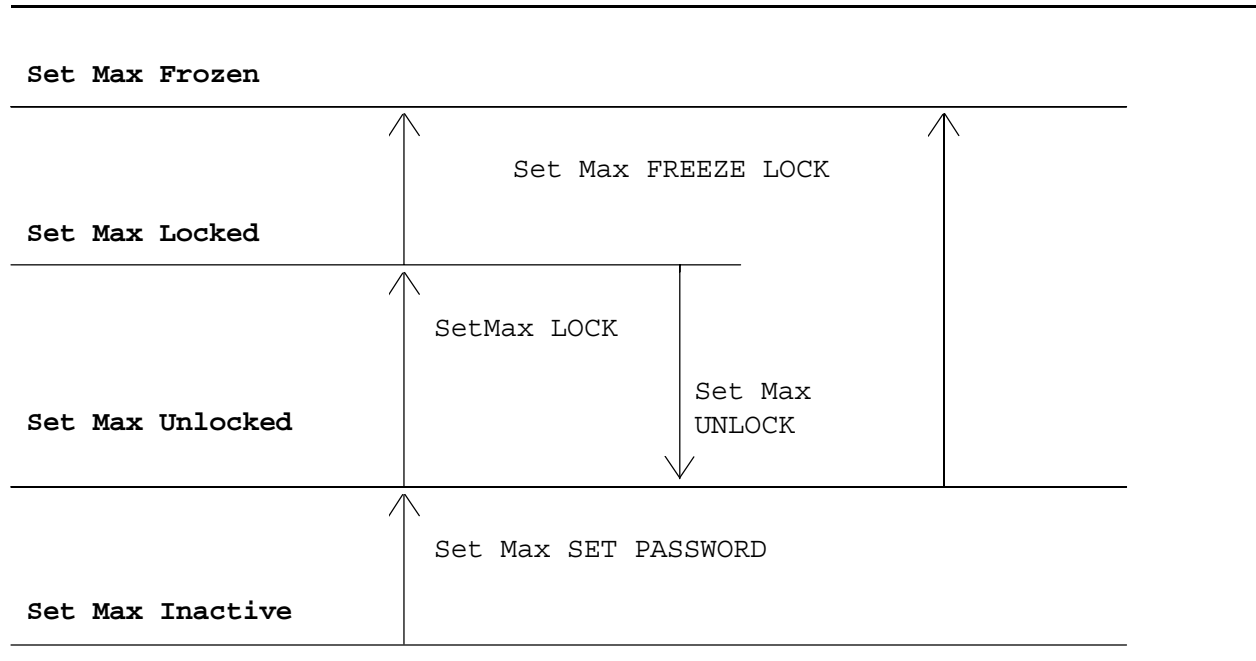

Figure 69. Set Max security mode transition

---

## 11.11 Address Offset Feature (vendor specific)

Computer systems perform initial code loading (booting) by reading from a predefined address on a disk drive. To allow an alternate bootable operating system to exist in a reserved area on a disk drive this feature provides a Set Features function to temporarily offset the drive address space. The offset address space wraps around so that the entire disk drive address space remains addressable in offset mode. The Set Max pointer is set to the end of the reserved area to protect the data in the user area when operating in offset mode. This protection can be removed by a Set Max Address command to move the Set Max pointer to the end of the drive. But any commands which access sectors across the original native maximum LBA are rejected with error, even if this protection is removed by a Set Max Address command.

### 11.11.1 Enable/Disable Address Offset Mode

Subcommand code 09h Enable Address Offset Mode offsets address Cylinder 0, Head 0, Sector 1, LBA 0, to the start of the nonvolatile protected area established using the Set Max Address command. The offset condition is cleared by Subcommand 89h Disable Address Offset Mode, Hardware reset or Power on Reset. If Reverting to Power on Defaults has been enabled by Set Features command, it is cleared by Soft reset as well. Upon entering offset mode the capacity of the drive returned in the Identify Device data is the size of the former protected area. A subsequent Set Max Address command with the address returned by the Read Max Address command allows access to the entire drive. Addresses wrap so the entire drive remains addressable.

If a nonvolatile protected area has not been established before the device receives a Set Features Enable Address Offset Mode command, the command fails with Abort error status.

Disable Address Offset Feature removes the address offset and sets the size of the drive reported by the Identify Device command back to the size specified in the last nonvolatile Set Max Address command.

---

Before Enable Address Offset Mode

A reserved area has been created using a non-volatile Set Max command.

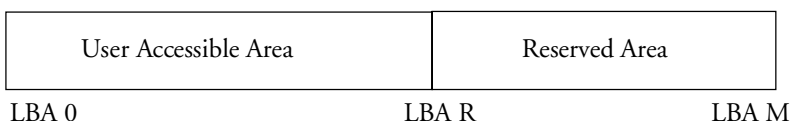

After Enable Address Offset Mode

The former reserved area is now the user accessible area.

The former user accessible area is now the reserved area.

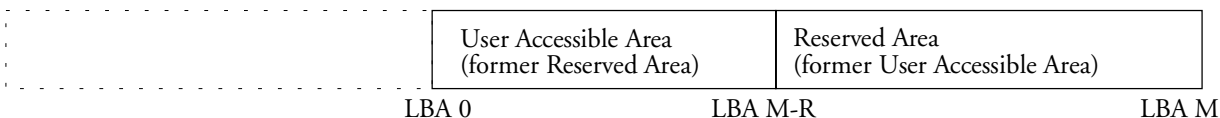

After Set Max Address Command using the Value Returned by Read Max Address

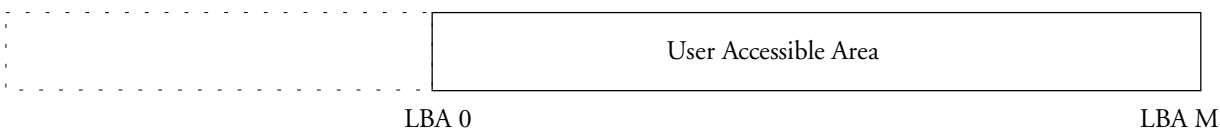

---

Figure 70. Device address map before and after Set Feature

### **11.11.2 Identify Device Data**

Identify Device data, word 83, bit 7 indicates the device supports the Address Offset Feature. Identify Device data, word 86, bit 7 indicates the device is in Address Offset mode.

### **11.11.3 Exceptions in Address Offset Mode**

Any commands which access sectors across the original native maximum LBA are rejected with error, even if the access protection is removed by a Set Max Address command.

Read Look Ahead operation is not carried out, even if it is enabled by the Set Feature command.

## 11.12 Seek Overlap

The drive provides accurate seek time measurement method. The seek command is usually used to measure the device seek time by accumulating execution time for a number of seek commands. With typical implementation of the seek command, this measurement must include the device and host command overhead. To eliminate this overhead, the drive overlaps the seek command as described below.

The first seek command completes before the actual seek operation is over. Then the device can receive the next seek command from the host. However, the actual seek operation for the next seek command starts right after completion of the actual seek operation for the first seek command. The execution of two seek commands overlaps excluding the actual seek operation.

With this overlap, total elapsed time for a number of seek commands is the total accumulated time for the actual seek operation plus one pre and post overhead. When the number of seeks is large, this overhead can be ignored.

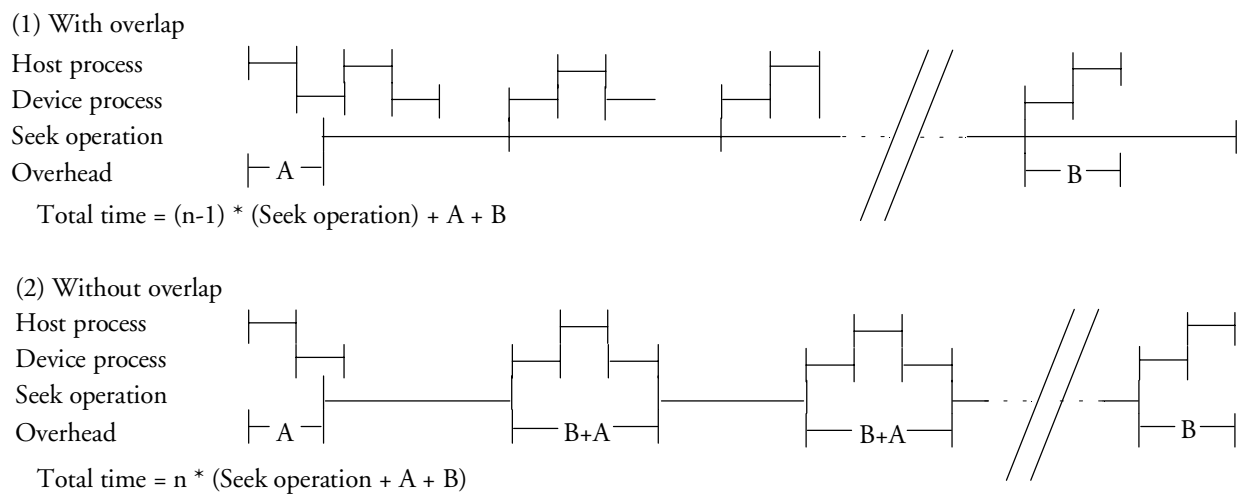

Figure 70. Seek overlap

---

## 11.13 Write Cache function

Write cache is a performance enhancement whereby the device reports completion of the write command (Write Sectors and Write Multiple) to the host as soon as the device has received all of the data in its buffer. The device assumes responsibility to write the data subsequently onto the disk.

- Even though writing data after completed acknowledgment of a write command, soft reset, or hard reset does not affect its operation, power off terminates writing operation immediately and unwritten data is lost.
- Flush cache, Soft reset, Standby, Standby Immediate, and Sleep are executed after the completion of writing to disk media on enabling write cache function. The host system can confirm the completion of write cache operation by issuing flush cache command, Soft reset, Standby command, Standby Immediate command, or Sleep command, and confirming the completion of the issued command.

---

## 11.14 Delayed Write function (vendor specific)

Delayed Write function is a power saving enhancement whereby the device delays the actual data writing into the media. When the device is in the power saving mode and the Write command (Write Sectors, Write Multiple, or Write DMA) comes from the host, the transferred data is not written into the media immediately, it is only stored into the cache buffer. When the cache buffer becomes full or reaches the predefined size or if any command except the Write command is issued, the operation to write the data from the cache buffer into the media is begun.

Power consumption can be reduced by Delayed Write. When Write commands come with a long interval, the device must exit from the power saving mode and enter into the power saving mode again without Delayed Write function. If Delayed Write is enabled, such power saving mode transition times can be reduced. As a result, the additional energy for power saving mode transition can be saved and the average power consumption of the device can be reduced.

However, the time elapsed from the completion of the Write command to the media write completion will be extended with Delayed Write function. If the power for the device is turned off during this time, the data which has not been written to the media is lost. Therefore, a command listed in the Write Cache Function section is issued before the power off to confirm whole cached data has been written into the media.

For the sake of safety, Delayed Write function is disabled at Power On Default. The Enable Delayed Write command is issued to the device to enable Delayed Write function at every Power On Reset or Hard Reset. The actions of each reset are shown in Figure 57 on page 74.

### 11.14.1 Enable/Disable Delayed Write command

Command code FAh with Feature register 07h enables Delayed Write function.

Command code FAh with Feature register 87h disables Delayed Write function.

Ensure that, even if Delayed Write function is enabled by this command, Delayed Write does not work when Write Cache function is disabled.

---

## 11.15 Reassign Function

The Reassign Function is used with read commands and write commands. The sectors of data for reassignment are prepared as the spare data sector. The one entry can register 256 consecutive sectors maximum.

This reassignment information is registered internally, and the information is available right after completing the reassign function. Also the information is used on the next power on reset or hard reset.

If the number of the spare sector reaches 0 sector, the reassign function will be disabled automatically.

The spare sectors for reassignment are located in a reserved area. As a result of reassignment, the physical location of logically sequenced sectors is dispersed.

### 11.15.1 Auto Reassign Function

The sectors that show some errors may be reallocated automatically when specific conditions are met. The spare sectors for reallocation are located in a reserved area. The conditions for auto-reallocation are described below.

#### **Nonrecovered write errors**

When a write operation can not be completed after the Error Recovery Procedure (ERP) is fully carried out, the sector(s) are reallocated to the spare location. An error is reported to the host system only when the write cache is disabled and the auto reallocation fails.

If the number of available spare sectors reaches 16 sectors, the write cache function will be disabled automatically.

#### **Nonrecovered read errors**

When a read operation fails after a defined ERP is fully carried out, a hard error is reported to the host system. This location is registered internally as a candidate for the reallocation. When a registered location is specified as a target of a write operation, a sequence of media verifications is performed automatically. When the result of this verification meets the criteria, this sector is reallocated.

#### **Recovered read errors**

When a read operation for a sector fails once and then is recovered at the specific ERP step, this sector of data is reallocated automatically. A media verification sequence may be run prior to the relocation according to the predefined conditions.

This page intentionally left blank.

---

## 12.0 Command protocol

The commands are grouped into different classes according to the protocols followed for command execution. The command classes with their associated protocols are defined below.

For all commands, the host must first check to see if BSY = 1, and should proceed no further unless and until BSY = 0. For all commands, the host must also wait for RDY = 1 before proceeding.

A device must maintain either BSY = 1 or DRQ = 1 at all times until the command is completed. The INTRQ signal is used by the device to signal most, but not all, times when the BSY bit is changed from 1 to 0 during command execution.

A command shall only be interrupted with a hardware or software reset. The result of writing to the Command register while BSY = 1 or DRQ = 1 is unpredictable and may result in data corruption. A command should only be interrupted by a reset at times when the host thinks there may be a problem, such as a device that is no longer responding.

Interrupts are cleared when the host reads the Status Register, issues a reset, or writes to the Command Register.

See Section 14.0, "Time-out values" on page 195 for the device time-out values.

---

## 12.1 Data In commands

These commands are:

- Identify Device
- Read Buffer
- Read Long
- Read Multiple
- Read Sectors
- S.M.A.R.T. Read Attribute Values
- S.M.A.R.T. Read Attribute Thresholds
- S.M.A.R.T. Read log sector

Execution includes the transfer of one or more 512 byte (> 512 bytes on Read Long) sectors of data from the device to the host.

1. The host writes any required parameters to the Features, Sector Count, Sector Number, Cylinder, and Device/Head Registers.
2. The host writes the command code to the Command Register.
3. For each sector (or block) of data to be transferred:
  - a. The device sets BSY = 1 and prepares for data transfer.
  - b. When a sector (or block) of data is available for transfer to the host, the device sets BSY = 0, sets DRQ = 1, and interrupts the host.
  - c. In response to the interrupt, the host reads the Status Register.
  - d. The device clears the interrupt in response to the Status Register being read.
  - e. The host reads one sector (or block) of data via the Data Register.

- f. The device sets DRQ = 0 after the sector (or block) has been transferred to the host.
4. For the Read Long command:
- a. The device sets BSY = 1 and prepares for data transfer.
  - b. When the sector of data is available for transfer to the host, the device sets BSY = 0 and DRQ = 1 and interrupts the host.
  - c. In response to the interrupt, the host reads the Status Register.
  - d. The device clears the interrupt in response to the Status Register being read.
  - e. The host reads the sector of data including ECC bytes via the Data Register.
  - f. The device sets DRQ = 0 after the sector has been transferred to the host.

The Read Multiple command transfers one block of data for each interrupt. The other commands transfer one sector of data for each interrupt.

Note that the status data for a sector of data is available in the Status Register before the sector is transferred to the host.

If the device detects an invalid parameter, then it will abort the command by setting BSY = 0, ERR = 1, ABT = 1, and interrupting the host.

If an error occurs, the device will set BSY = 0, ERR = 1, and DRQ = 1. The device will then store the error status in the Error Register and interrupt the host. The registers will contain the location of the sector in error. The error location will be reported using CHS mode or LBA mode. The mode is decided by the mode select bit (bit 6) of the Device/Head register upon issuing the command.

If an Uncorrectable Data Error (UNC = 1) occurs, the defective data will be transferred from the media to the sector buffer and will be available for transfer to the host at the host's option. In case of a Read Multiple command, the host should complete transfer of the block which includes the error from the sector buffer and terminate whatever type of error that occurred.

All data transfers to the host through the Data Register are 16 bits. The ECC bytes are an exception having only 8 bits.

---

## 12.2 Data Out commands

The following are Data Out commands:

- Device Configuration SET
- Format Track
- Security Disable Password
- Security Erase Unit
- Security Set Password
- Security Unlock
- Set Max SET PASSWORD
- Set Max UNLOCK
- S.M.A.R.T. Write log sector
- Write Buffer
- Write Long
- Write Multiple
- Write Sectors
- Write Verify

Execution includes the transfer of one or more 512 byte (> 512 bytes on Write Long) sectors of data from the host to the device.

1. The host writes any required parameters to the Features, Sector Count, Sector Number, Cylinder, and Device/Head Registers.
2. The host writes the command code to the Command Register.
3. The device sets BSY = 1.
4. For each sector (or block) of data to be transferred:
  - a. The device sets BSY = 0 and DRQ = 1 when it is ready to receive a sector (or block).
  - b. The host writes one sector (or block) of data via the Data Register.
  - c. The device sets BSY = 1 after it has received the sector (or block).
  - d. When the device has finished processing the sector (or block), it sets BSY = 0 and interrupts the host.
  - e. In response to the interrupt, the host reads the Status Register.
  - f. The device clears the interrupt in response to the Status Register being read.
5. For the Write Long command:
  - a. The device sets BSY = 0 and DRQ = 1 when it is ready to receive a sector.
  - b. The host writes one sector of data including ECC bytes via the Data Register.
  - c. The device sets BSY = 1 after it has received the sector.
  - d. After processing the sector of data the device sets BSY = 0 and interrupts the host.
  - e. In response to the interrupt, the host reads the Status Register.
  - f. The device clears the interrupt in response to the Status Register being read.

The Write Multiple command transfers one block of data for each interrupt. The other commands transfer one sector of data for each interrupt.

If the device detects an invalid parameter, then it will abort the command by setting BSY = 0, ERR = 1, ABT = 1, and interrupting the host.

If an uncorrectable error occurs, the device will set BSY = 0 and ERR = 1, store the error status in the Error Register, and interrupt the host. The registers will contain the location of the sector in error. The error location will be reported with CHS mode or LBA mode. The mode is decided by the mode select bit (bit 6) of the Device/Head register on issuing the command.

All data transfers to the host through the Data Register are 16 bits. The ECC bytes are an exception having only 8 bits.

---

## 12.3 Nondata commands

The following are Nondata commands:

- Check Power Mode
- Device Configuration FREEZE LOCK
- Device Configuration RESTORE
- Enable/Disable Delayed Write
- Execute Device Diagnostic
- Flush Cache
- Format Unit
- Idle
- Idle Immediate
- Initialize Device Parameters
- Read Native Max ADDRESS
- Read Verify Sectors
- Recalibrate
- Security Erase Prepare
- Security Freeze Lock
- Seek
- Sense Condition
- Set Features
- Set Max ADDRESS
- Set Max LOCK
- Set Max FREEZE LOCK
- Set Multiple Mode
- Sleep
- S.M.A.R.T. Disable Operations
- S.M.A.R.T. Enable/Disable Attribute Auto save
- S.M.A.R.T. Enable/Disable Automatic Off-line
- S.M.A.R.T. Enable Operations
- S.M.A.R.T. Execute Off-line Immediate
- S.M.A.R.T. Return Status
- S.M.A.R.T. Save Attribute Values
- Standby
- Standby Immediate

Execution of these commands involves no data transfer.

1. The host writes any required parameters to the Features, Sector Count, Sector Number, Cylinder, and Device/Head Registers.
2. The host writes the command code to the Command Register.
3. The device sets BSY = 1.
4. When the device has finished processing the command, it sets BSY = 0 and interrupts the host.
5. In response to the interrupt, the host reads the Status Register.
6. The device clears the interrupt in response to the Status Register being read.

---

## 12.4 DMA Data Transfer commands

These commands are:

- Read DMA
- Write DMA

Data transfers using DMA commands differ in two ways from PIO transfers:

- Data transfers are performed using the Slave DMA channel
- No intermediate sector interrupts are issued on multisector commands

Initiation of the DMA transfer commands is identical to the Read Sector or Write Sector commands with one exception: the host initializes the Slave DMA channel prior to issuing the command.

The interrupt handler for DMA transfers differs in two ways:

- No intermediate sector interrupts are issued on multisector commands.
- The host resets the DMA channel prior to reading status from the device.

The DMA protocol allows high performance multitasking operating systems to eliminate processor overhead associated with PIO transfers.

1. The host initializes the Slave DMA channel.
2. The host writes any required parameters to the Features, Sector Count, Sector Number, Cylinder, and Device/Head registers.
3. The host writes command code to the Command Register.
4. The device sets DMARQ when it is ready to transfer any part of the data.
5. The host transfers the data using the DMA transfer protocol currently in effect.
6. When all of the data has been transferred, the device generates an interrupt to the host.
7. The host resets the Slave DMA channel.
8. The host reads the Status Register and, optionally, the Error Register.

Refer to section 7.0, "Electrical interface specifications" on page 41 for further details.

## 13.0 Command descriptions

The table below shows the commands that are supported by the device. Figure 74 on page 113 shows the subcommands that are supported by each command or feature.

| Protocol | Command                          | Code<br>(Hex) | Binary Code Bit |   |   |   |   |   |   |   |
|----------|----------------------------------|---------------|-----------------|---|---|---|---|---|---|---|
|          |                                  |               | 7               | 6 | 5 | 4 | 3 | 2 | 1 | 0 |
| 3        | Check Power Mode                 | E5            | 1               | 1 | 1 | 0 | 0 | 1 | 0 | 1 |
| 3        | Check Power Mode*                | 98            | 1               | 0 | 0 | 1 | 1 | 0 | 0 | 0 |
| 3        | Device Configuration RESTORE     | B1            | 1               | 0 | 1 | 0 | 0 | 0 | 0 | 1 |
| 3        | Device Configuration FREEZE LOCK | B1            | 1               | 0 | 1 | 0 | 0 | 0 | 0 | 1 |
| 1        | Device Configuration IDENTIFY    | B1            | 1               | 0 | 1 | 0 | 0 | 0 | 0 | 1 |
| 2        | Device Configuration SET         | B1            | 1               | 0 | 1 | 0 | 0 | 0 | 0 | 1 |
| 3        | Enable/Disable Delayed Write     | FA            | 1               | 1 | 1 | 1 | 1 | 0 | 1 | 0 |
| 3        | Execute Device Diagnostic        | 90            | 1               | 0 | 0 | 1 | 0 | 0 | 0 | 0 |
| 3        | Flush Cache                      | E7            | 1               | 1 | 1 | 0 | 0 | 1 | 1 | 1 |
| 2        | Format Track                     | 50            | 0               | 1 | 0 | 1 | 0 | 0 | 0 | 0 |
| 3+       | Format Unit                      | F7            | 1               | 1 | 1 | 1 | 0 | 1 | 1 | 1 |
| 1        | Identify Device                  | EC            | 1               | 1 | 1 | 0 | 1 | 1 | 0 | 0 |
| 3        | Idle                             | E3            | 1               | 1 | 1 | 0 | 0 | 0 | 1 | 1 |
| 3        | Idle*                            | 97            | 1               | 0 | 0 | 1 | 0 | 1 | 1 | 1 |
| 3        | Idle Immediate                   | E1            | 1               | 1 | 1 | 0 | 0 | 0 | 0 | 1 |
| 3        | Idle Immediate*                  | 95            | 1               | 0 | 0 | 1 | 0 | 1 | 0 | 1 |
| 3        | Initialize Device Parameters     | 91            | 1               | 0 | 0 | 1 | 0 | 0 | 0 | 1 |
| 1        | Read Buffer                      | E4            | 1               | 1 | 1 | 0 | 0 | 1 | 0 | 0 |
| 4        | Read DMA                         | C8            | 1               | 1 | 0 | 0 | 1 | 0 | 0 | 0 |
| 4        | Read DMA                         | C9            | 1               | 1 | 0 | 0 | 1 | 0 | 0 | 1 |
| 1        | Read Long                        | 22            | 0               | 0 | 1 | 0 | 0 | 0 | 1 | 0 |
| 1        | Read Long                        | 23            | 0               | 0 | 1 | 0 | 0 | 0 | 1 | 1 |
| 1        | Read Multiple                    | C4            | 1               | 1 | 0 | 0 | 0 | 1 | 0 | 0 |
| 3        | Read Native Max ADDRESS          | F8            | 1               | 1 | 1 | 1 | 1 | 0 | 0 | 0 |
| 1        | Read Sectors                     | 20            | 0               | 0 | 1 | 0 | 0 | 0 | 0 | 0 |
| 1        | Read Sectors                     | 21            | 0               | 0 | 1 | 0 | 0 | 0 | 0 | 1 |
| 3        | Read Verify Sectors              | 40            | 0               | 1 | 0 | 0 | 0 | 0 | 0 | 0 |
| 3        | Read Verify Sectors              | 41            | 0               | 1 | 0 | 0 | 0 | 0 | 0 | 1 |
| 3        | Recalibrate                      | 1x            | 0               | 0 | 0 | 1 | - | - | - | - |
| 2        | Security Disable Password        | F6            | 1               | 1 | 1 | 1 | 1 | 0 | 1 | 0 |
| 3        | Security Erase Prepare           | F3            | 1               | 1 | 1 | 1 | 0 | 0 | 1 | 1 |
| 2        | Security Erase Unit              | F4            | 1               | 1 | 1 | 1 | 0 | 1 | 0 | 0 |
| 3        | Security Freeze Lock             | F5            | 1               | 1 | 1 | 1 | 0 | 1 | 0 | 1 |
| 2        | Security Set Password            | F1            | 1               | 1 | 1 | 1 | 0 | 0 | 0 | 1 |
| 2        | Security Unlock                  | F2            | 1               | 1 | 1 | 1 | 0 | 0 | 1 | 0 |
| 3        | Seek                             | 7x            | 0               | 1 | 1 | 1 | - | - | - | - |
| 3        | Sense Condition                  | F0            | 1               | 1 | 1 | 1 | 0 | 0 | 0 | 0 |
| 3        | Set Features                     | EF            | 1               | 1 | 1 | 0 | 1 | 1 | 1 | 1 |
| 3        | Set Max ADDRESS                  | F9            | 1               | 1 | 1 | 1 | 1 | 0 | 0 | 1 |
| 3        | Set Max FREEZE LOCK              | F9            | 1               | 1 | 1 | 1 | 1 | 0 | 0 | 1 |
| 3        | Set Max LOCK                     | F9            | 1               | 1 | 1 | 1 | 1 | 0 | 0 | 1 |
| 2        | Set Max SET PASSWORD             | F9            | 1               | 1 | 1 | 1 | 1 | 0 | 0 | 1 |

Figure 72. Command set (1 of 2)

| Protocol | Command  | Code<br>(Hex) | Binary Code Bit |   |   |   |   |   |   |   |
|----------|--|---------------|-----------------|---|---|---|---|---|---|---|
|          |  |               | 7               | 6 | 5 | 4 | 3 | 2 | 1 | 0 |
| 2        | Set Max UNLOCK                                   | F9            | 1               | 1 | 1 | 1 | 1 | 0 | 0 | 1 |
| 3        | Set Multiple Mode                                | C6            | 1               | 1 | 0 | 0 | 0 | 1 | 1 | 0 |
| 3        | Sleep  | E6            | 1               | 1 | 1 | 0 | 0 | 1 | 1 | 0 |
| 3        | Sleep*   | 99            | 1               | 0 | 0 | 1 | 1 | 0 | 0 | 1 |
| 3        | S.M.A.R.T. Disable Operations                    | B0            | 1               | 0 | 1 | 1 | 0 | 0 | 0 | 0 |
| 3        | S.M.A.R.T. Enable/Disable<br>Attribute Auto save | B0            | 1               | 0 | 1 | 1 | 0 | 0 | 0 | 0 |
| 3        | S.M.A.R.T. Enable/Disable<br>Automatic Off-line  | B0            | 1               | 0 | 1 | 1 | 0 | 0 | 0 | 0 |
| 3        | S.M.A.R.T. Enable Operations                     | B0            | 1               | 0 | 1 | 1 | 0 | 0 | 0 | 0 |
| 3        | S.M.A.R.T. Execute Off-line<br>Immediate         | B0            | 1               | 0 | 1 | 1 | 0 | 0 | 0 | 0 |
| 1        | S.M.A.R.T. Read Attribute Values                 | B0            | 1               | 0 | 1 | 1 | 0 | 0 | 0 | 0 |
| 1        | S.M.A.R.T. Read Attribute<br>Thresholds          | B0            | 1               | 0 | 1 | 1 | 0 | 0 | 0 | 0 |
| 1        | S.M.A.R.T. Read Log Sector                       | B0            | 1               | 0 | 1 | 1 | 0 | 0 | 0 | 0 |
| 3        | S.M.A.R.T. Return Status                         | B0            | 1               | 0 | 1 | 1 | 0 | 0 | 0 | 0 |
| 3        | S.M.A.R.T. Save Attribute Values                 | B0            | 1               | 0 | 1 | 1 | 0 | 0 | 0 | 0 |
| 2        | S.M.A.R.T. Write Log Sector                      | B0            | 1               | 0 | 1 | 1 | 0 | 0 | 0 | 0 |
| 3        | Standby  | E2            | 1               | 1 | 1 | 0 | 0 | 0 | 1 | 0 |
| 3        | Standby*   | 96            | 1               | 0 | 0 | 1 | 0 | 1 | 1 | 0 |
| 3        | Standby Immediate                                | E0            | 1               | 1 | 1 | 0 | 0 | 0 | 0 | 0 |
| 3        | Standby Immediate*                               | 94            | 1               | 0 | 0 | 1 | 0 | 1 | 0 | 0 |
| 2        | Write Buffer                                     | E8            | 1               | 1 | 1 | 0 | 1 | 0 | 0 | 0 |
| 4        | Write DMA  | CA            | 1               | 1 | 0 | 0 | 1 | 0 | 1 | 0 |
| 4        | Write DMA  | CB            | 1               | 1 | 0 | 0 | 1 | 0 | 1 | 1 |
| 2        | Write Long                                       | 32            | 0               | 0 | 1 | 1 | 0 | 0 | 1 | 0 |
| 2        | Write Long                                       | 33            | 0               | 0 | 1 | 1 | 0 | 0 | 1 | 1 |
| 2        | Write Multiple                                   | C5            | 1               | 1 | 0 | 0 | 0 | 1 | 0 | 1 |
| 2        | Write Sectors                                    | 30            | 0               | 0 | 1 | 1 | 0 | 0 | 0 | 0 |
| 2        | Write Sectors                                    | 31            | 0               | 0 | 1 | 1 | 0 | 0 | 0 | 1 |
| 2        | Write Verify                                     | 3C            | 0               | 0 | 1 | 1 | 1 | 1 | 0 | 0 |

Protocol: 1 : PIO data IN command  
2 : PIO data OUT command  
3 : Non data command  
4 : DMA command

Commands marked \* are alternate command codes for previously defined commands.

Figure 73. Command set (2 of 2)

| Command (Subcommand)                         | Command Code (Hex) | Feature Register (Hex) |
|--|--------------------|------------------------|
| (Delayed Write Function)                     |                    |                        |
| Enable Delayed Write function                | FA                 | 07                     |
| Disable Delayed Write function               | FA                 | 87                     |
| (S.M.A.R.T Function)                         |                    |                        |
| S.M.A.R.T. Read Attribute Values             | B0                 | D0                     |
| S.M.A.R.T. Read Attribute Thresholds         | B0                 | D1                     |
| S.M.A.R.T. Enable/Disable Attribute Autosave | B0                 | D2                     |
| S.M.A.R.T. Save Attribute Values             | B0                 | D3                     |
| S.M.A.R.T. Execute Off-line Immediate        | B0                 | D4                     |
| S.M.A.R.T. Read Log Sector                   | B0                 | D5                     |
| S.M.A.R.T. Write Log Sector                  | B0                 | D6                     |
| S.M.A.R.T. Enable Operations                 | B0                 | D8                     |
| S.M.A.R.T. Disable Operations                | B0                 | D9                     |
| S.M.A.R.T. Return Status                     | B0                 | DA                     |
| S.M.A.R.T. Enable/Disable Automatic Off-line | B0                 | DB                     |
| (Set Features)                               |                    |                        |
| Enable Write Cache                           | EF                 | 02                     |
| Set Transfer mode                            | EF                 | 03                     |
| Enable Advanced Power Management feature     | EF                 | 05                     |
| Enable Address Offset mode                   | EF                 | 09                     |
| 40 bytes of ECC apply on Read/Write Long     | EF                 | 44                     |
| Disable read look-ahead feature              | EF                 | 55                     |
| Disable reverting to power on defaults       | EF                 | 66                     |
| Disable write cache                          | EF                 | 82                     |
| Disable Advanced Power Management feature    | EF                 | 85                     |
| Disable Address Offset mode                  | EF                 | 89                     |
| Enable read look-ahead feature               | EF                 | AA                     |
| 4 bytes of ECC apply on Read/Write Long      | EF                 | BB                     |
| Enable reverting to power on defaults        | EF                 | CC                     |
| (Set Max Security Extension)                 |                    |                        |
| Set Max SET PASSWORD                         | F9                 | 01                     |
| Set Max LOCK                                 | F9                 | 02                     |
| Set Max UNLOCK                               | F9                 | 03                     |
| Set Max FREEZE LOCK                          | F9                 | 04                     |
| (Device Configuration Overlay)               |                    |                        |
| Device Configuration RESTORE                 | B1                 | C0                     |
| Device Configuration FREEZE LOCK             | B1                 | C1                     |
| Device Configuration IDENTIFY                | B1                 | C2                     |
| Device Configuration SET                     | B1                 | C3                     |

Figure 74. Command Set (Subcommand)

The following symbols are used in the command descriptions:

### Output Registers

- 0** This indicates that the bit must be set to 0.
- 1** This indicates that the bit must be set to 1.
- D** The device number bit. Indicates that the device number bit of the Device/Head Register should be specified. Zero selects the master device and one selects the slave device.
- H** Head number. This indicates that the head number part of the Device/Head Register is an output parameter and should be specified.
- L** LBA mode. This indicates the addressing mode. Zero specifies CHS mode and one specifies LBA addressing mode.
- R** Retry. Original meaning is already obsolete, there is no difference between 0 and 1. (Using 0 is recommended for future compatibility.)
- B** Option Bit. This indicates that the Option Bit of the Sector Count Register be specified. (This bit is used by Set Max ADDRESS command.)
- V** Valid. This indicates that the bit is part of an output parameter and should be specified.
- x** This indicates that the hex character is not used.
- This indicates that the bit is not used.

### Input Registers

- 0** This indicates that the bit is always set to 0.
- 1** This indicates that the bit is always set to 1.
- H** Head number. This indicates that the head number part of the Device/Head Register is an input parameter and will be set by the device.
- V** Valid. This indicates that the bit is part of an input parameter and will be set by the device to 0 or 1.
- N** Not recommended condition for start up. Indicates that the condition of the device is not recommended for start up.
- This indicates that the bit is not part of an input parameter.

The command descriptions show the contents of the Status and Error Registers after the device has completed processing the command and has interrupted the host.

## 13.1 Check Power Mode (E5h/98h)

| Command Block Output Registers |   |   |   |   |   |   |   | Command Block Input Registers |               |           |   |   |   |   |   |   |   |
|--------------------------------|---|---|---|---|---|---|---|-------------------------------|---------------|-----------|---|---|---|---|---|---|---|
| Register                       | 7 | 6 | 5 | 4 | 3 | 2 | 1 | 0                             | Register      | 7         | 6 | 5 | 4 | 3 | 2 | 1 | 0 |
| Data                           | - | - | - | - | - | - | - | -                             | Data          | -         | - | - | - | - | - | - | - |
| Feature                        | - | - | - | - | - | - | - | -                             | Error         | see below |   |   |   |   |   |   |   |
| Sector Count                   | - | - | - | - | - | - | - | -                             | Sector Count  | V         | V | V | V | V | V | V | V |
| Sector Number                  | - | - | - | - | - | - | - | -                             | Sector Number | -         | - | - | - | - | - | - | - |
| Cylinder Low                   | - | - | - | - | - | - | - | -                             | Cylinder Low  | -         | - | - | - | - | - | - | - |
| Cylinder High                  | - | - | - | - | - | - | - | -                             | Cylinder High | -         | - | - | - | - | - | - | - |
| Device/Head                    | 1 | - | 1 | D | - | - | - | -                             | Device/Head   | -         | - | - | - | - | - | - | - |
| Command                        | 1 | 1 | 1 | 0 | 0 | 1 | 0 | 1                             | Status        | see below |   |   |   |   |   |   |   |

| Error Register |     |   |     |   |     |     |     |
|----------------|-----|---|-----|---|-----|-----|-----|
| 7              | 6   | 5 | 4   | 3 | 2   | 1   | 0   |
| CRC            | UNC | 0 | IDN | 0 | ABT | T0N | AMN |
| 0              | 0   | 0 | 0   | 0 | V   | 0   | 0   |

| Status Register |     |    |     |     |     |     |     |
|-----------------|-----|----|-----|-----|-----|-----|-----|
| 7               | 6   | 5  | 4   | 3   | 2   | 1   | 0   |
| BSY             | RDY | DF | DSC | DRQ | COR | IDX | ERR |
| 0               | V   | 0  | -   | -   | 0   | -   | V   |

Figure 75. Check Power Mode command (E5h/98h)

The Check Power Mode command will report whether the device is spun up and the media is available for immediate access.

### Input parameters from the device

**Sector Count** This indicates the power mode code. The command returns FFh in the Sector Count Register if the spindle motor is at speed and the device is not in Standby or Sleep mode. Otherwise, the Sector Count Register is set to 0.

## 13.2 Device Configuration Overlay (B1h)

| Command Block Output Registers |   |   |   |   |   |   |   | Command Block Input Registers |               |           |   |   |   |   |   |   |   |
|--------------------------------|---|---|---|---|---|---|---|-------------------------------|---------------|-----------|---|---|---|---|---|---|---|
| Register                       | 7 | 6 | 5 | 4 | 3 | 2 | 1 | 0                             | Register      | 7         | 6 | 5 | 4 | 3 | 2 | 1 | 0 |
| Data                           | - | - | - | - | - | - | - | -                             | Data          | -         | - | - | - | - | - | - | - |
| Feature                        | 1 | 0 | 1 | 0 | V | V | V | V                             | Error         | see below |   |   |   |   |   |   |   |
| Sector Count                   | - | - | - | - | - | - | - | -                             | Sector Count  | V         | V | V | V | V | V | V | V |
| Sector Number                  | - | - | - | - | - | - | - | -                             | Sector Number | -         | - | - | - | - | - | - | - |
| Cylinder Low                   | - | - | - | - | - | - | - | -                             | Cylinder Low  | V         | V | V | V | V | V | V | V |
| Cylinder High                  | - | - | - | - | - | - | - | -                             | Cylinder High | V         | V | V | V | V | V | V | V |
| Device/Head                    | - | - | - | D | - | - | - | -                             | Device/Head   | -         | - | - | - | - | - | - | - |
| Command                        | 1 | 0 | 1 | 1 | 0 | 0 | 0 | 1                             | Status        | see below |   |   |   |   |   |   |   |

| Error Register |     |   |     |   |     |     |     |
|----------------|-----|---|-----|---|-----|-----|-----|
| 7              | 6   | 5 | 4   | 3 | 2   | 1   | 0   |
| CRC            | UNC | 0 | IDN | 0 | ABT | T0N | AMN |
| 0              | 0   | 0 | 0   | 0 | V   | 0   | 0   |

| Status Register |     |    |     |     |     |     |     |
|-----------------|-----|----|-----|-----|-----|-----|-----|
| 7               | 6   | 5  | 4   | 3   | 2   | 1   | 0   |
| BSY             | RDY | DF | DSC | DRQ | COR | IDX | ERR |
| V               | V   | V  | -   | V   | -   | -   | V   |

Figure 76. Check Power Mode Command (E5h/98h)

Individual Device Configuration Overlay feature set commands are identified by the value placed in the Features register. The table below shows these Features register values.

| Value | Command                          |
|-------|----------------------------------|
| C0h   | DEVICE CONFIGURATION RESTORE     |
| C1h   | DEVICE CONFIGURATION FREEZE LOCK |
| C2h   | DEVICE CONFIGURATION IDENTIFY    |
| C3h   | DEVICE CONFIGURATION SET         |
| other | Reserved                         |

Figure 77. Device Configuration Overlay Features register values

### 13.2.1 DEVICE CONFIGURATION RESTORE (subcommand C0h)

The DEVICE CONFIGURATION RESTORE command disables any setting previously made by a DEVICE CONFIGURATION SET command and returns the content of the IDENTIFY DEVICE or IDENTIFY PACKET DEVICE command response to the original settings as indicated by the data returned from the execution of a DEVICE CONFIGURATION IDENTIFY command.

## 13.2.2 DEVICE CONFIGURATION FREEZE LOCK (subcommand C1h)

The DEVICE CONFIGURATION FREEZE LOCK command prevents accidental modification of the Device Configuration Overlay settings. After successful execution of a DEVICE CONFIGURATION FREEZE LOCK command, all DEVICE CONFIGURATION SET, DEVICE CONFIGURATION FREEZE LOCK, DEVICE CONFIGURATION IDENTIFY, and DEVICE CONFIGURATION RESTORE commands are aborted by the device. The DEVICE CONFIGURATION FREEZE LOCK condition shall be cleared by a power-down. The DEVICE CONFIGURATION FREEZE LOCK condition shall not be cleared by hardware or software reset.

## 13.2.3 DEVICE CONFIGURATION IDENTIFY (subcommand C2h)

The DEVICE CONFIGURATION IDENTIFY command returns a 512 byte data structure via PIO data-in transfer. The content of this data structure indicates the selectable commands, modes, and feature sets that the device is capable of supporting. If a DEVICE CONFIGURATION SET command has been issued reducing the capabilities, the response to an IDENTIFY DEVICE or IDENTIFY PACKET DEVICE command will reflect the reduced set of capabilities, while the DEVICE CONFIGURATION IDENTIFY command will reflect the entire set of selectable capabilities.

The format of the Device Configuration Overlay data structure is shown on the next page.

## 13.2.4 DEVICE CONFIGURATION SET (subcommand C3h)

The DEVICE CONFIGURATION SET command allows a device manufacturer or a personal computer system manufacturer to reduce the set of optional commands, modes, or feature sets supported by a device as indicated by a DEVICE CONFIGURATION IDENTIFY command. The DEVICE CONFIGURATION SET command transfers an overlay that modifies some of the bits set in words 63, 82, 83, 84, and 88 of the IDENTIFY DEVICE command response. When the bits in these words are cleared, the device no longer support the indicated command, mode, or feature set. If a bit is set in the overlay transmitted by the device that is not set in the overlay received from a DEVICE CONFIGURATION IDENTIFY command, no action is taken for that bit.

The format of the overlay transmitted by the device is described in the table on the next page. The restrictions on changing these bits is described in the text following that table. If any of the bit modification restrictions described are violated or any setting is changed with DEVICE CONFIGURATION SET command, the device shall return command aborted. At that case, error reason code is returned to sector count register, invalid word location is returned to cylinder high register, and invalid bit location is returned to cylinder low register. The Definition of error information is shown on the next page.

### ERROR INFORMATION EXAMPLE 1:

After establishing a protected area with SET MAX address, if a user attempts to change maximum LBA address (DC SET or DC RESTORE), the device aborts that command and returns error reason code as below.

```
Cylinder high : 03h = word 3 is invalid
Cylinder low  : 00h this register is not assigned in this case
Sector count  : 06h = Protected area is now established
```

## ERROR INFORMATION EXAMPLE 2:

When the device is enabled and the Security feature is set, if the user attempts to disable that feature, the device aborts that command and returns an error reason code as below.

```
Cylinder high   : 07h = word 7 is invalid
Cylinder low    : 03h = bit 3 is invalid
Sector count    : 04h = now Security feature set is enabled
```

| Word  | Content   |
|-------|---|
| 0     | 0001h   Data Structure revision   |
| 1     | Multiword DMA modes supported<br>15-3   Reserved<br>2   1 = Multiword DMA mode 2 and below are supported<br>1   1 = Multiword DMA mode 1 and below are supported<br>0   1 = Multiword DMA mode 0 is supported   |
| 2     | Ultra DMA modes supported<br>15-6   Reserved<br>5   1 = Ultra DMA mode 5 and below are supported<br>4   1 = Ultra DMA mode 4 and below are supported<br>3   1 = Ultra DMA mode 3 and below are supported<br>2   1 = Ultra DMA mode 2 and below are supported<br>1   1 = Ultra DMA mode 1 and below are supported<br>0   1 = Ultra DMA mode 0 is supported |
| 3-6   | Maximum LBA address   |
| 7     | Command set/feature set supported<br>15-8   Reserved<br>7   1 = Host Protected Area feature set supported<br>6-4   Reserved<br>3   1 = Security feature set supported<br>2   1 = SMART error log supported<br>1   1 = SMART self-test supported<br>0   1 = SMART feature set supported  |
| 8-254 | Reserved  |
| 255   | Integrity word <see note below><br>15-8   Checksum<br>7-0   Signature (A5h)   |

Figure 78. Device Configuration Overlay Data structure

*Note:* Bits 7–0 of this word contain the value A5h. Bits 15–8 of this word contain the data structure checksum. The data structure checksum is the two's complement of the sum of all byte in words 0 through 254 and the byte consisting of bits 7–0 of word 255. Each byte is added with unsigned arithmetic, and overflow is ignored. The sum of all bytes is zero when the checksum is correct.

|               |  |
|---------------|--|
| Cylinder high | invalid word location  |
| Cylinder low  | invalid bit location   |
| Sector count  | error reason code & description<br>01h DCO feature is frozen<br>02h Device is now Security Locked mode<br>03h Device's feature is already modified with DCO<br>04h User attempt to disable any feature enabled<br>05h Device is now SET MAX Locked or Frozen mode<br>06h Protected area is now established<br>07h DCO is not supported<br>08h Subcommand code is invalid<br>FFh other reason |

Figure 79. DCO error information definition

## 13.3 Enable/Disable Delayed Write (FAh: vendor specific)

| Command Block Output Registers |   |   |   |   |   |   |   | Command Block Input Registers |               |           |   |   |   |   |   |   |   |
|--------------------------------|---|---|---|---|---|---|---|-------------------------------|---------------|-----------|---|---|---|---|---|---|---|
| Register                       | 7 | 6 | 5 | 4 | 3 | 2 | 1 | 0                             | Register      | 7         | 6 | 5 | 4 | 3 | 2 | 1 | 0 |
| Data                           | - | - | - | - | - | - | - | -                             | Data          | -         | - | - | - | - | - | - | - |
| Feature                        | V | V | V | V | V | V | V | V                             | Error         | see below |   |   |   |   |   |   |   |
| Sector Count                   | - | - | - | - | - | - | - | -                             | Sector Count  | -         | - | - | - | - | - | - | - |
| Sector Number                  | - | - | - | - | - | - | - | -                             | Sector Number | -         | - | - | - | - | - | - | - |
| Cylinder Low                   | - | - | - | - | - | - | - | -                             | Cylinder Low  | -         | - | - | - | - | - | - | - |
| Cylinder High                  | - | - | - | - | - | - | - | -                             | Cylinder High | -         | - | - | - | - | - | - | - |
| Device/Head                    | 1 | - | 1 | D | - | - | - | -                             | Device/Head   | -         | - | - | - | - | - | - | - |
| Command                        | 1 | 1 | 1 | 1 | 1 | 0 | 1 | 0                             | Status        | see below |   |   |   |   |   |   |   |

| Error Register |     |   |     |   |     |     |     |
|----------------|-----|---|-----|---|-----|-----|-----|
| 7              | 6   | 5 | 4   | 3 | 2   | 1   | 0   |
| CRC            | UNC | 0 | IDN | 0 | ABT | T0N | AMN |
| 0              | 0   | 0 | 0   | 0 | V   | 0   | 0   |

| Status Register |     |    |     |     |     |     |     |
|-----------------|-----|----|-----|-----|-----|-----|-----|
| 7               | 6   | 5  | 4   | 3   | 2   | 1   | 0   |
| BSY             | RDY | DF | DSC | DRQ | COR | IDX | ERR |
| 0               | 0   | 0  | -   | -   | 0   | -   | V   |

Figure 80. Enable/Disable Delayed Write command (FAh)

The Enable/Disable Delayed Write command sets if the Delayed Write function is enabled or disabled. Delayed Write function is enabled or disabled according to the feature register's value.

Even if the Delayed Write function is enabled by this command, Delayed Write does not work when the Write Cache function is disabled.

For details for this function refer to section 11.14, "Delayed Write Function (Vendor Specific)" on page 98.

### Output parameters to the device

**Feature** This is the destination code for this command.

**07H** is the Enable Delayed Write function

**87H** is the Disable Delayed Write function

## 13.4 Execute Device Diagnostic (90h)

| Command Block Output Registers |   |   |   |   |   |   |   | Command Block Input Registers |               |           |   |   |   |   |   |   |   |
|--------------------------------|---|---|---|---|---|---|---|-------------------------------|---------------|-----------|---|---|---|---|---|---|---|
| Register                       | 7 | 6 | 5 | 4 | 3 | 2 | 1 | 0                             | Register      | 7         | 6 | 5 | 4 | 3 | 2 | 1 | 0 |
| Data                           | - | - | - | - | - | - | - | -                             | Data          | -         | - | - | - | - | - | - | - |
| Feature                        | - | - | - | - | - | - | - | -                             | Error         | see below |   |   |   |   |   |   |   |
| Sector Count                   | - | - | - | - | - | - | - | -                             | Sector Count  | -         | - | - | - | - | - | - | - |
| Sector Number                  | - | - | - | - | - | - | - | -                             | Sector Number | -         | - | - | - | - | - | - | - |
| Cylinder Low                   | - | - | - | - | - | - | - | -                             | Cylinder Low  | -         | - | - | - | - | - | - | - |
| Cylinder High                  | - | - | - | - | - | - | - | -                             | Cylinder High | -         | - | - | - | - | - | - | - |
| Device/Head                    | 1 | - | 1 | - | - | - | - | -                             | Device/Head   | -         | - | - | - | - | - | - | - |
| Command                        | 1 | 0 | 0 | 1 | 0 | 0 | 0 | 0                             | Status        | see below |   |   |   |   |   |   |   |

| Error Register |     |   |     |   |     |     |     |
|----------------|-----|---|-----|---|-----|-----|-----|
| 7              | 6   | 5 | 4   | 3 | 2   | 1   | 0   |
| CRC            | UNC | 0 | IDN | 0 | ABT | TON | AMN |
| 0              | V   | V | V   | V | V   | V   | V   |

| Status Register |     |    |     |     |     |     |     |
|-----------------|-----|----|-----|-----|-----|-----|-----|
| 7               | 6   | 5  | 4   | 3   | 2   | 1   | 0   |
| BSY             | RDY | DF | DSC | DRQ | COR | IDX | ERR |
| 0               | 0   | 0  | -   | -   | 0   | -   | 0   |

Figure 81. Execute Device Diagnostic command (90h)

The Execute Device Diagnostic command performs the internal diagnostic tests implemented by the device. The results of the test are stored in the Error Register.

The normal Error Register bit definitions do not apply to this command. Instead, the register contains a diagnostic code. See Figure 59 on page 75 for the definition.

## 13.5 Flush Cache (E7h)

| Command Block Output Registers |   |   |   |   |   |   |   | Command Block Input Registers |               |           |   |   |   |   |   |   |   |
|--------------------------------|---|---|---|---|---|---|---|-------------------------------|---------------|-----------|---|---|---|---|---|---|---|
| Register                       | 7 | 6 | 5 | 4 | 3 | 2 | 1 | 0                             | Register      | 7         | 6 | 5 | 4 | 3 | 2 | 1 | 0 |
| Data                           | - | - | - | - | - | - | - | -                             | Data          | -         | - | - | - | - | - | - | - |
| Feature                        | - | - | - | - | - | - | - | -                             | Error         | see below |   |   |   |   |   |   |   |
| Sector Count                   | - | - | - | - | - | - | - | -                             | Sector Count  | -         | - | - | - | - | - | - | - |
| Sector Number                  | - | - | - | - | - | - | - | -                             | Sector Number | -         | - | - | - | - | - | - | - |
| Cylinder Low                   | - | - | - | - | - | - | - | -                             | Cylinder Low  | -         | - | - | - | - | - | - | - |
| Cylinder High                  | - | - | - | - | - | - | - | -                             | Cylinder High | -         | - | - | - | - | - | - | - |
| Device/Head                    | 1 | - | 1 | D | - | - | - | -                             | Device/Head   | -         | - | - | - | - | - | - | - |
| Command                        | 1 | 1 | 1 | 0 | 0 | 1 | 1 | 1                             | Status        | see below |   |   |   |   |   |   |   |

| Error Register |     |   |     |   |     |     |     |
|----------------|-----|---|-----|---|-----|-----|-----|
| 7              | 6   | 5 | 4   | 3 | 2   | 1   | 0   |
| CRC            | UNC | 0 | IDN | 0 | ABT | TON | AMN |
| 0              | 0   | 0 | 0   | 0 | V   | 0   | 0   |

| Status Register |     |    |     |     |     |     |     |
|-----------------|-----|----|-----|-----|-----|-----|-----|
| 7               | 6   | 5  | 4   | 3   | 2   | 1   | 0   |
| BSY             | RDY | DF | DSC | DRQ | COR | IDX | ERR |
| 0               | V   | 0  | V   | -   | 0   | -   | V   |

Figure 82. Flush Cache command (E7h)

This command causes the device to complete writing data from its cache.

The device returns a status of RDY = 1 and DSC = 1 (50h) after following sequence:

- Data in the write cache buffer is written to the disk media.

Return a successful completion

## 13.6 Format Track (50h: vendor specific)

| Command Block Output Registers |   |   |   |   |   |   |   | Command Block Input Registers |               |           |   |   |   |   |   |   |   |
|--------------------------------|---|---|---|---|---|---|---|-------------------------------|---------------|-----------|---|---|---|---|---|---|---|
| Register                       | 7 | 6 | 5 | 4 | 3 | 2 | 1 | 0                             | Register      | 7         | 6 | 5 | 4 | 3 | 2 | 1 | 0 |
| Data                           | - | - | - | - | - | - | - | -                             | Data          | -         | - | - | - | - | - | - | - |
| Feature                        | - | - | - | - | - | - | - | -                             | Error         | see below |   |   |   |   |   |   |   |
| Sector Count                   | - | - | - | - | - | - | - | -                             | Sector Count  | -         | - | - | - | - | - | - | - |
| Sector Number                  | V | V | V | V | V | V | V | V                             | Sector Number | V         | V | V | V | V | V | V | V |
| Cylinder Low                   | V | V | V | V | V | V | V | V                             | Cylinder Low  | V         | V | V | V | V | V | V | V |
| Cylinder High                  | V | V | V | V | V | V | V | V                             | Cylinder High | V         | V | V | V | V | V | V | V |
| Device/Head                    | 1 | L | 1 | D | H | H | H | H                             | Device/Head   | -         | - | - | - | H | H | H | H |
| Command                        | 0 | 1 | 0 | 1 | 0 | 0 | 0 | 0                             | Status        | see below |   |   |   |   |   |   |   |

| Error Register |     |   |     |   |     |     |     |
|----------------|-----|---|-----|---|-----|-----|-----|
| 7              | 6   | 5 | 4   | 3 | 2   | 1   | 0   |
| CRC            | UNC | 0 | IDN | 0 | ABT | TON | AMN |
| 0              | 0   | 0 | V   | 0 | V   | 0   | 0   |

| Status Register |     |    |     |     |     |     |     |
|-----------------|-----|----|-----|-----|-----|-----|-----|
| 7               | 6   | 5  | 4   | 3   | 2   | 1   | 0   |
| BSY             | RDY | DF | DSC | DRQ | COR | IDX | ERR |
| 0               | V   | V  | V   | -   | 0   | -   | V   |

Figure 83. Format Track command (50h)

The Format Track command formats a single logical track on the device. Each good sector of data on the track will be initialized to zero with the write operation. At this time, the read operation does not verify the correct initialization of the data sector. Any data previously stored on the track will be lost.

### Output parameters to the device

**Sector Number** In LBA mode this register specifies that LBA address bits 0–7 are to be formatted. (L = 1)

**Cylinder High/Low** This indicates the cylinder number of the track to be formatted. (L = 0)  
In LBA mode this register specifies that LBA address bits 8–15 (Low) and bits 16–23 (High) are to be formatted. (L = 1)

**H** This indicates the head number of the track to be formatted. (L = 0)  
In LBA mode this register specifies that LBA address bits 24–27 are to be formatted. (L = 1)

### Input parameters from the device

**Sector Number** In LBA mode this register specifies the current LBA address bits as 0–7 (L = 1).

**Cylinder High/Low** In LBA mode this register specifies the current LBA address bits as 8–15 (Low) and bits 16–23 (High).

**H** In LBA mode this register specifies the current LBA address bits as 24–27 (L = 1).  
In LBA mode this command formats a single logical track including the specified LBA.

## 13.7 Format Unit (F7h: vendor specific)

| Command Block Output Registers |   |   |   |   |   |   |   | Command Block Input Registers |               |           |   |   |   |   |   |   |   |
|--------------------------------|---|---|---|---|---|---|---|-------------------------------|---------------|-----------|---|---|---|---|---|---|---|
| Register                       | 7 | 6 | 5 | 4 | 3 | 2 | 1 | 0                             | Register      | 7         | 6 | 5 | 4 | 3 | 2 | 1 | 0 |
| Data                           | - | - | - | - | - | - | - | -                             | Data          | -         | - | - | - | - | - | - | - |
| Feature                        | V | V | V | V | V | V | V | V                             | Error         | see below |   |   |   |   |   |   |   |
| Sector Count                   | - | - | - | - | - | - | - | -                             | Sector Count  | -         | - | - | - | - | - | - | - |
| Sector Number                  | - | - | - | - | - | - | - | -                             | Sector Number | -         | - | - | - | - | - | - | - |
| Cylinder Low                   | - | - | - | - | - | - | - | -                             | Cylinder Low  | -         | - | - | - | - | - | - | - |
| Cylinder High                  | - | - | - | - | - | - | - | -                             | Cylinder High | -         | - | - | - | - | - | - | - |
| Device/Head                    | 1 | - | 1 | D | - | - | - | -                             | Device/Head   | -         | - | - | - | - | - | - | - |
| Command                        | 1 | 1 | 1 | 1 | 0 | 1 | 1 | 1                             | Status        | see below |   |   |   |   |   |   |   |

| Error Register |     |   |     |   |     |     |     |
|----------------|-----|---|-----|---|-----|-----|-----|
| 7              | 6   | 5 | 4   | 3 | 2   | 1   | 0   |
| CRC            | UNC | 0 | IDN | 0 | ABT | TON | AMN |
| 0              | 0   | 0 | V   | 0 | V   | 0   | 0   |

| Status Register |     |    |     |     |     |     |     |
|-----------------|-----|----|-----|-----|-----|-----|-----|
| 7               | 6   | 5  | 4   | 3   | 2   | 1   | 0   |
| BSY             | RDY | DF | DSC | DRQ | COR | IDX | ERR |
| 0               | V   | 0  | V   | -   | 0   | -   | V   |

Figure 84. Format Unit command (F7h)

The Format Unit command initializes all user data sectors after merging the reassigned sector location into the defect information of the device and clearing the reassign information. Both new reassign information and new defect information are available right after the completion of this command. They are also used on the next power on reset or hard reset. This command erases both previous information data from the device.

Note that the Format Unit command initializes from LBA 0 to Native MAX LBA. Host MAX LBA is set by Initialize Drive Parameter or Set MAX ADDRESS command is ignored. The protected area by Set MAX ADDRESS command is also initialized.

The Security Erase Prepare command should be completed immediately prior to the Format Unit command. If the device receives a Format Unit command without a prior Security Erase Prepare command, the device aborts the Format Unit command.

If the Feature register is NOT 11h, the device returns an Abort error to the host.

This command does not request a data transfer.

### Output parameters to the device

**Feature** This indicates the Destination code for this command.  
**11H** The merge reassigned location into the defect information.

The execution time of this command is shown below.

| <b>Model number</b> | <b>Execution time</b> |
|---------------------|-----------------------|
| IC25T060ATCS05      | 60 min                |
| IC25N040ATCS04      | 44 min                |
| IC25N030ATCS04      | 34 min                |
| IC25N020ATCS04      | 22 min                |
| IC25N010ATCS04      | 12 min                |

## 13.8 Identify Device (ECh)

| Command Block Output Registers |   |   |   |   |   |   |   | Command Block Input Registers |               |           |   |   |   |   |   |   |   |
|--------------------------------|---|---|---|---|---|---|---|-------------------------------|---------------|-----------|---|---|---|---|---|---|---|
| Register                       | 7 | 6 | 5 | 4 | 3 | 2 | 1 | 0                             | Register      | 7         | 6 | 5 | 4 | 3 | 2 | 1 | 0 |
| Data                           | - | - | - | - | - | - | - | -                             | Data          | -         | - | - | - | - | - | - | - |
| Feature                        | - | - | - | - | - | - | - | -                             | Error         | see below |   |   |   |   |   |   |   |
| Sector Count                   | - | - | - | - | - | - | - | -                             | Sector Count  | -         | - | - | - | - | - | - | - |
| Sector Number                  | - | - | - | - | - | - | - | -                             | Sector Number | -         | - | - | - | - | - | - | - |
| Cylinder Low                   | - | - | - | - | - | - | - | -                             | Cylinder Low  | -         | - | - | - | - | - | - | - |
| Cylinder High                  | - | - | - | - | - | - | - | -                             | Cylinder High | -         | - | - | - | - | - | - | - |
| Device/Head                    | 1 | - | 1 | D | - | - | - | -                             | Device/Head   | -         | - | - | - | - | - | - | - |
| Command                        | 1 | 1 | 1 | 0 | 1 | 1 | 0 | 0                             | Status        | see below |   |   |   |   |   |   |   |

| Error Register |     |   |     |   |     |     |     |
|----------------|-----|---|-----|---|-----|-----|-----|
| 7              | 6   | 5 | 4   | 3 | 2   | 1   | 0   |
| CRC            | UNC | 0 | IDN | 0 | ABT | TON | AMN |
| 0              | 0   | 0 | 0   | 0 | V   | 0   | 0   |

| Status Register |     |    |     |     |     |     |     |
|-----------------|-----|----|-----|-----|-----|-----|-----|
| 7               | 6   | 5  | 4   | 3   | 2   | 1   | 0   |
| BSY             | RDY | DF | DSC | DRQ | COR | IDX | ERR |
| 0               | V   | 0  | -   | -   | 0   | -   | V   |

Figure 85. Identify Device command (ECh)

The Identify Device command requests the device to transfer configuration information to the host. The device will transfer a sector to the host containing the information in Figure 86. beginning on page 123.

| Word    | Content                    | Description  |  |
|---------|----------------------------|--|--|
| 00      | 045AH                      | drive classification   |  |
|         |                            | bit assignments  |  |
|         |                            | 15(=0)   | 1=ATAPI device, 0=ATA device                 |
|         |                            | * 14(=0)   | 1=format speed tolerance gap required        |
|         |                            | * 13(=0)   | 1=track offset option available              |
|         |                            | * 12(=0)   | 1=data strobe offset option available        |
|         |                            | * 11(=0)   | 1=rotational speed tolerance > 0.5%          |
|         |                            | * 10(=1)   | 1=disk transfer rate > 10 Mbps               |
|         |                            | * 9(=0)  | 1=disk transfer rate > 5 Mbps but <= 10 Mbps |
|         |                            | * 8(=0)  | 1=disk transfer rate <= 5 Mbps               |
|         |                            | 7(=0)  | 1=removable cartridge drive                  |
|         |                            | 6(=1)  | 1=fixed drive                                |
|         |                            | * 5(=0)  | 1=spindle motor control option implemented   |
|         |                            | * 4(=1)  | 1=head switch time > 15 μs                   |
|         |                            | * 3(=1)  | 1=not MFM encoded                            |
| 2(=0)   | 1=identify data incomplete |  |  |
| * 1(=1) | 1=hard sectoring           |  |  |
| 0(=0)   | Reserved                   |  |  |
| 01      | (Note 1)                   | Number of cylinders in default translate mode  |  |
| 02      | C837H                      | SET FEATURES subcommand is not required to spin-up and IDENTIFY DEVICE response is complete  |  |
| 03      | (Note 1)                   | Number of heads in default translate mode  |  |
| 04      | 0 *                        | Reserved   |  |
| 05      | 0 *                        | Reserved   |  |
| 06      | 003FH                      | Number of sectors per track in default translate mode  |  |
| 07      | 0                          | Reserved   |  |
| 08      | 0                          | Reserved   |  |
| 09      | 0000H *                    | Reserved   |  |
| 10-19   | XXXX                       | Serial number in ASCII (0 = not specified)   |  |
| 20      | 0003H *                    | Controller type:<br>0003: dual ported, multiple sector buffer with look-ahead read   |  |
| 21      | (Note 1) *                 | Buffer size in 512-byte increments   |  |
| 22      | 00XXH *                    | Number of ECC bytes as currently selected via the set feature command  |  |
| 23-26   | XXXX                       | Micro code version in ASCII  |  |
| 27-46   | (Note 1)                   | Model number in ASCII  |  |
| 47      | 8010H                      | Maximum number of sectors that can be transferred per interrupt on Read and Write Multiple commands<br>15-8: (=80h)<br>7-0: Maximum number of sectors that can be transferred per interrupt. |  |

\* in Content field indicates the use of those parameters that are vendor specific.

Note 1. See Figure 93.

Figure 86. Identify device information. (Part 1 of 7)

| Word  | Content  | Description  |
|-------|----------|--|
| 48    | 0000H *  | Capable of double word I/O, '0000'= cannot perform   |
| 49    | 0F00H *  | Capabilities, bit assignments:<br>15-14 (=0) Reserved<br>13 (=0) Standby timer value are vendor specific<br>12 (=0) Reserved<br>11 (=1) IORDY Supported<br>10 (=1) IORDY can be disabled<br>9 (=1) Reserved<br>8 (=0) Reserved<br>7-0 (=0) Reserved  |
| 50    | 4000H    | Capabilities<br>15 (=0) 0=the contents of word 50 are valid<br>14 (=1) 1=the contents of word 50 are valid<br>13- 1 (=0) Reserved<br>0 (=0) 1=the device has a minimum Standby timer value that is device specific   |
| 51    | 0200H *  | PIO data transfer cycle timing mode  |
| 52    | 0200H *  | DMA data transfer cycle timing mode<br>Refer Word 62 and 63  |
| 53    | 0007H    | Validity flag of the word<br>15- 3 (=0) Reserved<br>2 (=1) 1=Word 88 is Valid<br>1 (=1) 1=Word 64-70 are Valid<br>0 (=1) 1=Word 54-58 are Valid  |
| 54    | XXXXH    | Number of current cylinders  |
| 55    | XXXXH    | Number of current heads  |
| 56    | XXXXH    | Number of current sectors per track  |
| 57-58 | XXXXH    | Current capacity in sectors<br>Word 57 specifies the low word of the capacity  |
| 59    | 0XXXXH   | Current Multiple setting. Bit assignments:<br>15- 9 (=0) Reserved<br>8 1= Multiple Sector Setting is Valid<br>7- 0 xxh = Current setting for number of sectors   |
| 60-61 | (Note 1) | Total Number of User Addressable Sectors<br>Word 60 specifies the low word of the number   |
| 62    | 0000H *  | Reserved   |
| 63    | XX07H    | Multiword DMA Transfer Capability<br>15-11 (=0) Reserved<br>10 1=Multiword DMA mode 2 is selected<br>9 1=Multiword DMA mode 1 is selected<br>8 1=Multiword DMA mode 0 is selected<br>7- 3 (=0) Reserved<br>2 1=Multiword DMA mode 2 is supported<br>1 1=Multiword DMA mode 1 is supported<br>0 1=Multiword DMA mode 0 is supported |

\* in Content field indicates the use of those parameters that are vendor specific.

Note 1. See Figure 93.

Figure 87. Identify device information. (Part 2 of 7)

| Word  | Content | Description  |
|-------|---------|--|
| 64    | 0003H   | Flow Control PIO Transfer Modes Supported<br>15- 8(=0) Reserved<br>7- 0(=3) Advanced PIO Transfer Modes Supported<br>'11' = PIO Mode 3 and 4 Supported   |
| 65    | 0078H   | Minimum Multiword DMA Transfer Cycle Time Per Word<br>15- 0(=78h) Cycle time in nanoseconds (120 ns, 16.6 MB/s)  |
| 66    | 0078H   | Manufacturer's Recommended Multiword DMA Transfer Cycle Time<br>15- 0(=78h) Cycle time in nanoseconds (120 ns, 16.6 MB/s)  |
| 67    | 00F0H   | Minimum PIO Transfer Cycle Time Without Flow Control<br>15- 0(=F0h) Cycle time in nanoseconds (240 ns, 8.3 MB/s)   |
| 68    | 0078H   | Minimum PIO Transfer Cycle Time With IORDY Flow Control<br>15- 0(=78h) Cycle time in nanoseconds (120 ns, 16.6 MB/s)   |
| 69-79 | 0000H   | Reserved   |
| 80    | 003CH   | Major version number<br>ATA-1, ATA-2, ATA-3 and ATA/ATAPI-4, ATA/ATAPI-5   |
| 81    | 0013H   | Minor version number<br>ATA/ATAPI-5 T13 1321D Revision 3   |
| 82    | 746BH   | Command set supported<br>15(=0) Reserved<br>14(=1) 1=NOP command supported<br>13(=1) 1=READ BUFFER command supported<br>12(=1) 1=WRITE BUFFER command supported<br>11(=0) Reserved<br>**10(=1) 1=Host Protected Area Feature Set supported<br>9(=0) 1=DEVICE RESET command supported<br>8(=0) 1=SERVICE interrupt supported<br>7(=0) 1=release interrupt supported<br>6(=1) 1=look-ahead supported<br>5(=1) 1=write cache supported<br>4(=0) 1=supported PACKET Command Feature Set<br>3(=1) 1=supported Power Management Feature Set<br>2(=0) 1=supported Removable Media Feature Set<br>** 1(=1) 1=supported Security Feature Set<br>** 0(=1) 1=supported S.M.A.R.T. Feature Set |

\* in Content field indicates the use of those parameters that are vendor specific.

\*\* indicates a feature that is able to be unsupported by the Device Configuration Overlay command.

Figure 88. Identify device information. (Part 3 of 7)

| Word | Content | Description   |
|------|---------|---|
| 83   | 49A8H   | Command set supported<br>15(=0) Always<br>14(=1) Always<br>13-12(=0) Reserved<br>11(=1) 1=Device Configuration Overlay command supported<br>10- 9(=0) Reserved<br>** 8(=1) 1=SET MAX security extension supported<br>** 7(=1) 1=Address Offset feature supported<br>6(=0) 1=SET FEATURES subcommand required to spin-up<br>5(=1) 1=Power-Up In Standby feature set supported<br>4(=0) 1=Removable Media Status Notification Feature Set supported<br>3(=1) 1=Advanced Power Management Feature Set supported<br>2(=0) 1=CFA Feature Set supported<br>1(=0) 1=READ/WRITE DMA QUEUED supported<br>0(=0) 1=DOWNLOAD MICROCODE command supported                        |
| 84   | 4003H   | Command set/feature supported extension<br>15(=0) Always<br>14(=1) Always<br>13- 2(=0) Reserved<br>** 1(=1) 1=SMART self-test supported<br>** 0(=1) 1=SMART error logging supported   |
| 85   | F4XXH   | Command set/feature enabled<br>15(=1) Reserved<br>14(=1) 1=NOP command supported<br>13(=1) 1=READ BUFFER command supported<br>12(=1) 1=WRITE BUFFER command supported<br>11(=0) Reserved<br>**10(=1) 1=Host Protected Area Feature Set supported<br>9(=0) 1=DEVICE RESET command supported<br>8(=0) 1=SERVICE interrupt enabled<br>7(=0) 1=release interrupt enabled<br>6(=X) 1=look-ahead enabled<br>5(=X) 1=write cache enabled<br>4(=0) 1=supports PACKET Command Feature Set<br>3(=X) 1=supports Power Management Feature Set<br>2(=0) 1=supports Removable Media Feature Set<br>1(=X) 1=Security Feature Set enabled<br>0(=X) 1=S.M.A.R.T. Feature Set enabled |

\* in Content field indicates the use of those parameters that are vendor specific.

\*\* indicates a feature that is able to be unsupported by the Device Configuration Overlay command.

Figure 89. Identify device information. (Part 4 of 7)

| Word | Content | Description  |
|------|---------|--|
| 86   | 0XXXH   | Command set/feature enabled<br>* 15-12(=0) Reserved<br>11(=1) 1=Device Configuration Overlay supported<br>* 10- 9(=0) Reserved<br>8(=X) 1=SET MAX security extension enabled<br>* 7(=X) 1=Address Offset mode enabled<br>6(=0) 1=SET FEATURES subcommand required to spin-up<br>5(=0) 1=Power-Up In Standby feature set has been<br>enabled via the SET FEATURES command<br>4(=0) 1=Removable Media Status Notification Feature<br>Set enabled<br>3(=X) 1=Advanced Power management Feature Set<br>enabled<br>2(=0) 1=CFA Feature Set supported<br>1(=0) 1=READ/WRITE DMA QUEUED command supported<br>0(=0) 1=DOWNLOAD MICROCODE command supported |
| 87   | 4003H   | Command set/feature enabled<br>15(=0) Always<br>14(=1) Always<br>13- 2(=0) Reserved<br>1(=1) 1=SMART self-test supported<br>0(=1) 1=SMART error logging supported  |
| 88   | XX3FH   | Ultra DMA Transfer mode (mode 5 supported)<br>15-14(=0) Reserved<br>13(=X) 1=UltraDMA mode 5 is selected<br>12(=X) 1=UltraDMA mode 4 is selected<br>11(=X) 1=UltraDMA mode 3 is selected<br>10(=X) 1=UltraDMA mode 2 is selected<br>9(=X) 1=UltraDMA mode 1 is selected<br>8(=X) 1=UltraDMA mode 0 is selected<br>7- 6(=0) Reserved<br>**5(=1) 1=UltraDMA mode 5 is selected<br>**4(=1) 1=UltraDMA mode 4 is supported<br>**3(=1) 1=UltraDMA mode 3 is supported<br>**2(=1) 1=UltraDMA mode 2 is supported<br>**1(=1) 1=UltraDMA mode 1 is supported<br>0(=1) 1=UltraDMA mode 0 is supported   |
| 89   | XXXXH   | Time required for security erase unit completion<br>Time= value (XXXXh)*2 [minutes]  |
| 90   | 0000H   | Time required for Enhance security erase completion<br>0000 : Not supported  |
| 91   | 40FEH   | Reserved   |
| 92   | XXXXH   | Current Master Password Revision Codes   |

\*\* indicates a feature that is able to be unsupported by the Device Configuration Overlay command.

Figure 90. Identify device information. (Part 5 of 7)

| Word   | Content | Description   |
|--------|---------|---|
| 93     | XXXXH   | <p>Hardware reset results</p> <p>15-13 Device detected result</p> <p>15(=0) Reserved</p> <p>14(=1) Always</p> <p>13(=X) 1=Device detected CBLID- above V<sub>iH</sub><br/>0=Device detected CBLID- below V<sub>iL</sub></p> <p>12- 8 Device 1 hardware reset result<br/>Device 0 clear these bits to 0</p> <p>12(=0) Reserved</p> <p>11(=X) 1=Device 1 passed diagnostic</p> <p>10-9(=X) how Device 1 determined the device number:<br/>00=Reserved<br/>01=a jumper was used<br/>10=the CSEL signal was used<br/>11=some other method used or method unknown</p> <p>8(=1) Always</p> <p>7- 0 Device 0 hardware reset result<br/>Device 1 clears these bits to 0</p> <p>7(=0) Reserved</p> <p>6(=X) 1=Semi-duplex mode is enabled</p> <p>5(=X) 1=Device 0 detected Device 1</p> <p>4(=X) 1=Device 1 passed diagnostic</p> <p>3(=X) 1=Device 0 passed diagnostic</p> <p>2-1(=X) how Device 0 determined the device number:<br/>00=Reserved<br/>01=a jumper was used<br/>10=the CSEL signal was used<br/>11=some other method used or the method unknown</p> <p>0(=1) Always</p> |
| 94-127 | 0000H   | Reserved  |
| 128    | 0XXXH   | <p>Security Mode Feature. Bit assignments</p> <p>15-9(=0) Reserved</p> <p>8(=X) Security Level: 1= Maximum, 0= High</p> <p>7-6(=0) Reserved</p> <p>5(=0) 1=Enhanced security erase supported</p> <p>4(=0) 1=Security count expired</p> <p>3(=0) 1=Security Frozen</p> <p>2(=0) 1=Security Locked</p> <p>1(=0) 1=Security Enabled</p> <p>**0(=0) 1=Security Support</p>  |

\* in Content field indicates the use of those parameters that are vendor specific.

\*\* indicates a feature that is able to be unsupported by the Device Configuration Overlay command.

Figure 91. Identify device information. (Part 6 of 7)

| Word    | Content | Description  |
|---------|---------|--|
| 129     | 000XH * | Current Set Feature Option. Bit assignments<br>15-4(=0) Reserved<br>3(=X) 1=Auto reassign enabled<br>2(=X) 1=Reverting enabled<br>1(=X) 1=Read Look-ahead enabled<br>0(=X) 1=Write Cache enabled |
| 130     | XXXXH * | Reserved   |
| 131     | 000XH * | Initial Power Mode Selection. Bit assignments<br>15-2(=0) Reserved<br>1(=1) Always<br>0(=X) Initial Power Mode: 1=Standby, 0=Idle  |
| 132-254 | 0000H * | Reserved   |
| 255     | XXA5H   | Integrity word<br>15-8(=XX) Checksum<br>7-0(=A5) Signature   |

Figure 92. Identify device information. (Part 7 of 7)

|                           |                 |
|---------------------------|-----------------|
| <b>Microcode revision</b> | <b>CAxOAxXX</b> |
|---------------------------|-----------------|

IC25T060ATCS05-0

|  |                  |
|--|------------------|
| Number of cylinders                      | 3FFFh            |
| Number of heads                          | 10h              |
| Buffer size                              | 0DD0h (=1,768KB) |
| Total number of user addressable sectors | 6FC7C80h         |

IC25N040ATCS04-0

|  |                  |
|--|------------------|
| Number of cylinders                      | 3FFFh            |
| Number of heads                          | 10h              |
| Buffer size                              | 0DD0h (=1,768KB) |
| Total number of user addressable sectors | 4A85300h         |

IC25N030ATCS04-0

|  |                  |
|--|------------------|
| Number of cylinders                      | 3FFFh            |
| Number of heads                          | 10h              |
| Buffer size                              | 0DD0h (=1,768KB) |
| Total number of user addressable sectors | 37E3E40h         |

IC25N020ATCS04-0

|  |                  |
|--|------------------|
| Number of cylinders                      | 3FFFh            |
| Number of heads                          | 10h              |
| Buffer size                              | 0DD0h (=1,768KB) |
| Total number of user addressable sectors | 2542980h         |

IC25N010ATCS04-0

|  |                  |
|--|------------------|
| Number of cylinders                      | 3FFFh            |
| Number of heads                          | 10h              |
| Buffer size                              | 0DD0h (=1,768KB) |
| Total number of user addressable sectors | 12BB230h         |

Figure 93. Number of cylinders/heads/sectors by model.

For the microcode revision refer to 13.8, "Identify Device (ECh)" on page 122. This is 8 characters in ASCII.

## 13.9 Idle (E3h/97h)

| Command Block Output Registers |   |   |   |   |   |   |   | Command Block Input Registers |               |           |   |   |   |   |   |   |   |
|--------------------------------|---|---|---|---|---|---|---|-------------------------------|---------------|-----------|---|---|---|---|---|---|---|
| Register                       | 7 | 6 | 5 | 4 | 3 | 2 | 1 | 0                             | Register      | 7         | 6 | 5 | 4 | 3 | 2 | 1 | 0 |
| Data                           | - | - | - | - | - | - | - | -                             | Data          | -         | - | - | - | - | - | - | - |
| Feature                        | - | - | - | - | - | - | - | -                             | Error         | see below |   |   |   |   |   |   |   |
| Sector Count                   | V | V | V | V | V | V | V | V                             | Sector Count  | -         | - | - | - | - | - | - | - |
| Sector Number                  | - | - | - | - | - | - | - | -                             | Sector Number | -         | - | - | - | - | - | - | - |
| Cylinder Low                   | - | - | - | - | - | - | - | -                             | Cylinder Low  | -         | - | - | - | - | - | - | - |
| Cylinder High                  | - | - | - | - | - | - | - | -                             | Cylinder High | -         | - | - | - | - | - | - | - |
| Device/Head                    | 1 | - | 1 | D | - | - | - | -                             | Device/Head   | -         | - | - | - | - | - | - | - |
| Command                        | 1 | 1 | 1 | 0 | 0 | 0 | 1 | 1                             | Status        | see below |   |   |   |   |   |   |   |

| Error Register |     |   |     |   |     |     |     |
|----------------|-----|---|-----|---|-----|-----|-----|
| 7              | 6   | 5 | 4   | 3 | 2   | 1   | 0   |
| CRC            | UNC | 0 | IDN | 0 | ABT | T0N | AMN |
| 0              | 0   | 0 | 0   | 0 | V   | 0   | 0   |

| Status Register |     |    |     |     |     |     |     |
|-----------------|-----|----|-----|-----|-----|-----|-----|
| 7               | 6   | 5  | 4   | 3   | 2   | 1   | 0   |
| BSY             | RDY | DF | DSC | DRQ | COR | IDX | ERR |
| 0               | V   | 0  | V   | -   | 0   | -   | V   |

Figure 94. Idle command (E3h/97h)

When the power save mode is Standby mode, the Idle command causes the device to enter Performance Idle mode immediately and sets the auto power down time-out Parameter (standby timer). At the set of the auto power down time-out parameter (standby timer) the point timer starts counting down. When the power save mode is already any idle mode, the device remains in that mode.

When the Idle mode is entered, the device is spun up to operating speed. If the device is already spinning, the spin up sequence is not executed.

During Idle mode the device is spinning and is ready to respond to host commands immediately.

### Input parameters to the device

**Sector Count** This indicates the Time-out Parameter. If it is zero, the time-out interval (Standby Timer) is NOT disabled and the time-out interval is set automatically for 109 minutes. If it is other than zero, the time-out interval is set for (Time-out Parameter × 5) seconds.

The device will enter Standby mode automatically if the time-out interval expires with no device access from the host. The time-out interval will be reinitialized if there is a device access before the time-out interval expires.

## 13.10 Idle Immediate (E1h/95h)

| Command Block Output Registers |   |   |   |   |   |   |   | Command Block Input Registers |               |           |   |   |   |   |   |   |   |
|--------------------------------|---|---|---|---|---|---|---|-------------------------------|---------------|-----------|---|---|---|---|---|---|---|
| Register                       | 7 | 6 | 5 | 4 | 3 | 2 | 1 | 0                             | Register      | 7         | 6 | 5 | 4 | 3 | 2 | 1 | 0 |
| Data                           | - | - | - | - | - | - | - | -                             | Data          | -         | - | - | - | - | - | - | - |
| Feature                        | - | - | - | - | - | - | - | -                             | Error         | see below |   |   |   |   |   |   |   |
| Sector Count                   | - | - | - | - | - | - | - | -                             | Sector Count  | -         | - | - | - | - | - | - | - |
| Sector Number                  | - | - | - | - | - | - | - | -                             | Sector Number | -         | - | - | - | - | - | - | - |
| Cylinder Low                   | - | - | - | - | - | - | - | -                             | Cylinder Low  | -         | - | - | - | - | - | - | - |
| Cylinder High                  | - | - | - | - | - | - | - | -                             | Cylinder High | -         | - | - | - | - | - | - | - |
| Device/Head                    | 1 | - | 1 | D | - | - | - | -                             | Device/Head   | -         | - | - | - | - | - | - | - |
| Command                        | 1 | 1 | 1 | 0 | 0 | 0 | 0 | 1                             | Status        | see below |   |   |   |   |   |   |   |

| Error Register |     |   |     |   |     |     |     |
|----------------|-----|---|-----|---|-----|-----|-----|
| 7              | 6   | 5 | 4   | 3 | 2   | 1   | 0   |
| CRC            | UNC | 0 | IDN | 0 | ABT | T0N | AMN |
| 0              | 0   | 0 | 0   | 0 | V   | 0   | 0   |

| Status Register |     |    |     |     |     |     |     |
|-----------------|-----|----|-----|-----|-----|-----|-----|
| 7               | 6   | 5  | 4   | 3   | 2   | 1   | 0   |
| BSY             | RDY | DF | DSC | DRQ | COR | IDX | ERR |
| 0               | V   | 0  | V   | -   | 0   | -   | V   |

Figure 95. Idle Immediate command (E1h/95h)

The Idle Immediate command causes the device to enter Performance Idle mode.

The device is spun up to operating speed. If the device is already spinning, the spin up sequence is not executed.

During Idle mode the device is spinning and ready to respond to the host commands immediately.

The Idle Immediate command will not affect the auto power down time-out parameter.

## 13.11 Initialize Device Parameters (91h)

| Command Block Output Registers |   |   |   |   |   |   |   | Command Block Input Registers |               |           |   |   |   |   |   |   |   |
|--------------------------------|---|---|---|---|---|---|---|-------------------------------|---------------|-----------|---|---|---|---|---|---|---|
| Register                       | 7 | 6 | 5 | 4 | 3 | 2 | 1 | 0                             | Register      | 7         | 6 | 5 | 4 | 3 | 2 | 1 | 0 |
| Data                           | - | - | - | - | - | - | - | -                             | Data          | -         | - | - | - | - | - | - | - |
| Feature                        | - | - | - | - | - | - | - | -                             | Error         | -         | - | - | - | - | - | - | - |
| Sector Count                   | V | V | V | V | V | V | V | V                             | Sector Count  | -         | - | - | - | - | - | - | - |
| Sector Number                  | - | - | - | - | - | - | - | -                             | Sector Number | -         | - | - | - | - | - | - | - |
| Cylinder Low                   | - | - | - | - | - | - | - | -                             | Cylinder Low  | -         | - | - | - | - | - | - | - |
| Cylinder High                  | - | - | - | - | - | - | - | -                             | Cylinder High | -         | - | - | - | - | - | - | - |
| Device/Head                    | 1 | - | 1 | D | H | H | H | H                             | Device/Head   | -         | - | - | - | - | - | - | - |
| Command                        | 1 | 0 | 0 | 1 | 0 | 0 | 0 | 1                             | Status        | see below |   |   |   |   |   |   |   |

| Error Register |     |   |     |   |     |     |     |
|----------------|-----|---|-----|---|-----|-----|-----|
| 7              | 6   | 5 | 4   | 3 | 2   | 1   | 0   |
| CRC            | UNC | 0 | IDN | 0 | ABT | T0N | AMN |
| 0              | 0   | 0 | 0   | 0 | V   | 0   | 0   |

| Status Register |     |    |     |     |     |     |     |
|-----------------|-----|----|-----|-----|-----|-----|-----|
| 7               | 6   | 5  | 4   | 3   | 2   | 1   | 0   |
| BSY             | RDY | DF | DSC | DRQ | COR | IDX | ERR |
| 0               | 0   | 0  | -   | -   | 0   | -   | V   |

Figure 96. Initialize Device Parameters command (91h)

The Initialize Device Parameters command enables the host to set the number of sectors per track and the number of heads minus 1, per cylinder. Words 54–58 in Identify Device Information reflects these parameters.

The parameters remain in effect until the following events occur:

- Another Initialize Device Parameters command is received.
- The device is powered off.
- A hard reset occurs.
- A soft reset occurs and the Set Feature option of CCh is set.

### Input parameters to the device

**Sector Count** This indicates the number of sectors per track. Zero (0) does not mean that there are 256 sectors per track. It means that there are no sectors per track.

**H** This indicates the number of heads minus 1 per cylinder. The minimum is 0 and the maximum is 15.

## 13.12 Read Buffer (E4h)

| Command Block Output Registers |   |   |   |   |   |   |   | Command Block Input Registers |               |           |   |   |   |   |   |   |   |
|--------------------------------|---|---|---|---|---|---|---|-------------------------------|---------------|-----------|---|---|---|---|---|---|---|
| Register                       | 7 | 6 | 5 | 4 | 3 | 2 | 1 | 0                             | Register      | 7         | 6 | 5 | 4 | 3 | 2 | 1 | 0 |
| Data                           | - | - | - | - | - | - | - | -                             | Data          | -         | - | - | - | - | - | - | - |
| Feature                        | - | - | - | - | - | - | - | -                             | Error         | see below |   |   |   |   |   |   |   |
| Sector Count                   | - | - | - | - | - | - | - | -                             | Sector Count  | -         | - | - | - | - | - | - | - |
| Sector Number                  | - | - | - | - | - | - | - | -                             | Sector Number | -         | - | - | - | - | - | - | - |
| Cylinder Low                   | - | - | - | - | - | - | - | -                             | Cylinder Low  | -         | - | - | - | - | - | - | - |
| Cylinder High                  | - | - | - | - | - | - | - | -                             | Cylinder High | -         | - | - | - | - | - | - | - |
| Device/Head                    | 1 | - | 1 | D | - | - | - | -                             | Device/Head   | -         | - | - | - | - | - | - | - |
| Command                        | 1 | 1 | 1 | 0 | 0 | 1 | 0 | 0                             | Status        | see below |   |   |   |   |   |   |   |

| Error Register |     |   |     |   |     |     |     |
|----------------|-----|---|-----|---|-----|-----|-----|
| 7              | 6   | 5 | 4   | 3 | 2   | 1   | 0   |
| CRC            | UNC | 0 | IDN | 0 | ABT | TON | AMN |
| 0              | 0   | 0 | 0   | 0 | V   | 0   | 0   |

| Status Register |     |    |     |     |     |     |     |
|-----------------|-----|----|-----|-----|-----|-----|-----|
| 7               | 6   | 5  | 4   | 3   | 2   | 1   | 0   |
| BSY             | RDY | DF | DSC | DRQ | COR | IDX | ERR |
| 0               | V   | 0  | -   | -   | 0   | -   | V   |

Figure 97. Read Buffer command (E4h)

The Read Buffer command transfers a sector of data from the sector buffer of the device to the host.

The sector is transferred through the Data Register 16 bits at a time.

The sector transferred will be from the same part of the buffer written to by the last Write Buffer command. The contents of the sector may be different if any reads or writes have occurred since the Write Buffer command was issued.

## 13.13 Read DMA (C8h/C9h)

| Command Block Output Registers |   |   |   |   |   |   |   | Command Block Input Registers |               |           |   |   |   |   |   |   |   |
|--------------------------------|---|---|---|---|---|---|---|-------------------------------|---------------|-----------|---|---|---|---|---|---|---|
| Register                       | 7 | 6 | 5 | 4 | 3 | 2 | 1 | 0                             | Register      | 7         | 6 | 5 | 4 | 3 | 2 | 1 | 0 |
| Data                           | - | - | - | - | - | - | - | -                             | Data          | -         | - | - | - | - | - | - | - |
| Feature                        | - | - | - | - | - | - | - | -                             | Error         | see below |   |   |   |   |   |   |   |
| Sector Count                   | V | V | V | V | V | V | V | V                             | Sector Count  | V         | V | V | V | V | V | V | V |
| Sector Number                  | V | V | V | V | V | V | V | V                             | Sector Number | V         | V | V | V | V | V | V | V |
| Cylinder Low                   | V | V | V | V | V | V | V | V                             | Cylinder Low  | V         | V | V | V | V | V | V | V |
| Cylinder High                  | V | V | V | V | V | V | V | V                             | Cylinder High | V         | V | V | V | V | V | V | V |
| Device/Head                    | 1 | L | 1 | D | H | H | H | H                             | Device/Head   | -         | - | - | - | H | H | H | H |
| Command                        | 1 | 1 | 0 | 0 | 1 | 0 | 0 | R                             | Status        | see below |   |   |   |   |   |   |   |

| Error Register |     |   |     |   |     |     |     |
|----------------|-----|---|-----|---|-----|-----|-----|
| 7              | 6   | 5 | 4   | 3 | 2   | 1   | 0   |
| CRC            | UNC | 0 | IDN | 0 | ABT | T0N | AMN |
| V              | V   | 0 | V   | 0 | V   | 0   | V   |

| Status Register |     |    |     |     |     |     |     |
|-----------------|-----|----|-----|-----|-----|-----|-----|
| 7               | 6   | 5  | 4   | 3   | 2   | 1   | 0   |
| BSY             | RDY | DF | DSC | DRQ | COR | IDX | ERR |
| 0               | V   | 0  | V   | -   | 0   | -   | V   |

Figure 98. Read DMA command (C8h/C9h)

The Read DMA command reads one or more sectors of data from disk media and then transfers the data from the device to the host. It transfers the sectors through the Data Register 16 bits at a time.

The host initializes a slave-DMA channel prior to issuing the command. The data transfers are qualified by the DMARQ and are performed by the slave-DMA channel. The device issues only one interrupt per command to indicate that the data transfer has terminated and that status is available.

If an uncorrectable error occurs, the read will be terminated at the failing sector.

### Output parameters to the device

- Sector Count** This indicates the number of continuous sectors to be transferred. If zero is specified, then 256 sectors will be transferred.
- Sector Number** This indicates the sector number of the first sector to be transferred. (L = 0). In LBA mode, this register specifies that LBA address bits 0–7 are to be transferred. (L = 1)
- Cylinder High/Low** This indicates the cylinder number of the first sector to be transferred. (L = 0) In LBA mode, this register specifies LBA address bits 8–15 (Low) and 16–23 (High) to be transferred. (L = 1)
- H** This indicates the head number of the first sector to be transferred. (L = 0) In LBA mode this register specifies the LBA bits 24–27 to be transferred. (L = 1)
- R** This indicates the retry bit, but this bit is ignored.

### **Input parameters from the device**

|                          |   |
|--------------------------|---|
| <b>Sector Count</b>      | This indicates the number of requested sectors not transferred. This will be zero, unless an unrecoverable error occurs.  |
| <b>Sector Number</b>     | This indicates the sector number of the last transferred sector. (L = 0)<br>In LBA mode this register contains the current LBA bits 0–7. (L = 1)                                |
| <b>Cylinder High/Low</b> | This indicates the cylinder number of the last transferred sector. (L = 0)<br>In LBA mode this register contains the current LBA bits 8–15 (Low) and bits 16–23 (High). (L = 1) |
| <b>H</b>                 | This indicates the head number of the sector to be transferred. (L = 0) In LBA mode this register contains the current LBA bits 24–27. (L = 1)                                  |

## 13.14 Read Long (22h/23h)

| Command Block Output Registers |   |   |   |   |   |   |   | Command Block Input Registers |               |           |   |   |   |   |   |   |   |
|--------------------------------|---|---|---|---|---|---|---|-------------------------------|---------------|-----------|---|---|---|---|---|---|---|
| Register                       | 7 | 6 | 5 | 4 | 3 | 2 | 1 | 0                             | Register      | 7         | 6 | 5 | 4 | 3 | 2 | 1 | 0 |
| Data                           | - | - | - | - | - | - | - | -                             | Data          | -         | - | - | - | - | - | - | - |
| Feature                        | - | - | - | - | - | - | - | -                             | Error         | see below |   |   |   |   |   |   |   |
| Sector Count                   | 0 | 0 | 0 | 0 | 0 | 0 | 0 | 1                             | Sector Count  | -         | - | - | - | - | - | - | V |
| Sector Number                  | V | V | V | V | V | V | V | V                             | Sector Number | V         | V | V | V | V | V | V | V |
| Cylinder Low                   | V | V | V | V | V | V | V | V                             | Cylinder Low  | V         | V | V | V | V | V | V | V |
| Cylinder High                  | V | V | V | V | V | V | V | V                             | Cylinder High | V         | V | V | V | V | V | V | V |
| Device/Head                    | 1 | L | 1 | D | H | H | H | H                             | Device/Head   | -         | - | - | - | H | H | H | H |
| Command                        | 0 | 0 | 1 | 0 | 0 | 0 | 1 | R                             | Status        | see below |   |   |   |   |   |   |   |

| Error Register |     |   |     |   |     |     |     |
|----------------|-----|---|-----|---|-----|-----|-----|
| 7              | 6   | 5 | 4   | 3 | 2   | 1   | 0   |
| CRC            | UNC | 0 | IDN | 0 | ABT | T0N | AMN |
| 0              | 0   | 0 | V   | 0 | V   | 0   | V   |

| Status Register |     |    |     |     |     |     |     |
|-----------------|-----|----|-----|-----|-----|-----|-----|
| 7               | 6   | 5  | 4   | 3   | 2   | 1   | 0   |
| BSY             | RDY | DF | DSC | DRQ | COR | IDX | ERR |
| 0               | V   | 0  | V   | 0   | 0   | -   | V   |

Figure 99. Read Long command (22h/23h)

The Read Long command reads the designated one sector of data and the ECC bytes from the disk media. It then transfers the data and ECC bytes from the device to the host.

After 512 bytes of data have been transferred, the device will keep setting DRQ = 1 to indicate that the device is ready to transfer the ECC bytes to the host. The data is transferred 16 bits at a time and the ECC bytes are transferred 8 bits at a time. The number of ECC bytes are 4 or 40 according to the setting of Set Feature option. The default setting is 4 bytes of ECC data.

The command makes a single attempt to read the data and does not check the data using ECC. Whatever is read is returned to the host.

### Output parameters to the device

- Sector Count** This indicates the number of continuous sectors to be transferred. The Sector Count must be set to one.
- Sector Number** This indicates the sector number of the sector to be transferred. (L = 0) In LBA mode, this register contains LBA bits 0–7. (L = 1)
- Cylinder High/Low** This indicates the cylinder number of the sector to be transferred. (L = 0) In LBA mode, this register contains LBA bits 8–15 (Low), 16–23 (High). (L = 1)
- H** This indicates the head number of the sector to be transferred. (L = 0) In LBA mode, this register contains LBA bits 24–27. (L = 1)

**R** This indicates the retry bit, but this bit is ignored.

**Input parameters from the device**

**Sector Count** This indicates the number of requested sectors not transferred.

**Sector Number** This indicates the sector number of the transferred sector. (L = 0) In LBA mode, this register contains current LBA bits 0–7. (L = 1)

**Cylinder High/Low** This indicates the cylinder number of the transferred sector. (L = 0) In LBA mode, this register contains current LBA bits 8–15 (Low), 16–23 (High). (L = 1)

**H** This indicates the head number of the transferred sector. (L = 0) In LBA mode, this register contains current LBA bits 24–27. (L = 1)

The device internally uses 40 bytes of ECC data on all data written or read from the disk. The 4 byte mode of operation is provided via an emulation. Use of the 40 byte ECC mode is recommended for testing the effectiveness and integrity of the ECC functions of the device.

## 13.15 Read Multiple (C4h)

| Command Block Output Registers |   |   |   |   |   |   |   | Command Block Input Registers |               |           |   |   |   |   |   |   |   |
|--------------------------------|---|---|---|---|---|---|---|-------------------------------|---------------|-----------|---|---|---|---|---|---|---|
| Register                       | 7 | 6 | 5 | 4 | 3 | 2 | 1 | 0                             | Register      | 7         | 6 | 5 | 4 | 3 | 2 | 1 | 0 |
| Data                           | - | - | - | - | - | - | - | -                             | Data          | -         | - | - | - | - | - | - | - |
| Feature                        | - | - | - | - | - | - | - | -                             | Error         | see below |   |   |   |   |   |   |   |
| Sector Count                   | V | V | V | V | V | V | V | V                             | Sector Count  | V         | V | V | V | V | V | V | V |
| Sector Number                  | V | V | V | V | V | V | V | V                             | Sector Number | V         | V | V | V | V | V | V | V |
| Cylinder Low                   | V | V | V | V | V | V | V | V                             | Cylinder Low  | V         | V | V | V | V | V | V | V |
| Cylinder High                  | V | V | V | V | V | V | V | V                             | Cylinder High | V         | V | V | V | V | V | V | V |
| Device/Head                    | 1 | L | 1 | D | H | H | H | H                             | Device/Head   | -         | - | - | - | H | H | H | H |
| Command                        | 1 | 1 | 0 | 0 | 0 | 1 | 0 | 0                             | Status        | see below |   |   |   |   |   |   |   |

| Error Register |     |   |     |   |     |     |     |
|----------------|-----|---|-----|---|-----|-----|-----|
| 7              | 6   | 5 | 4   | 3 | 2   | 1   | 0   |
| CRC            | UNC | 0 | IDN | 0 | ABT | T0N | AMN |
| 0              | V   | 0 | V   | 0 | V   | 0   | V   |

| Status Register |     |    |     |     |     |     |     |
|-----------------|-----|----|-----|-----|-----|-----|-----|
| 7               | 6   | 5  | 4   | 3   | 2   | 1   | 0   |
| BSY             | RDY | DF | DSC | DRQ | COR | IDX | ERR |
| 0               | V   | 0  | V   | -   | 0   | -   | V   |

Figure 100. Read Multiple command (C4h)

The Read Multiple command reads one or more sectors of data from disk media and then transfers the data from the device to the host.

The sectors are transferred through the Data Register 16 bits at a time. The command execution is identical to the Read Sectors command with one exception: an interrupt is generated for each block—as defined by the Set Multiple command—instead of for each sector.

### Output parameters to the device

- Sector Count** This indicates the number of continuous sectors to be transferred. If zero is specified, 256 sectors will be transferred.
- Sector Number** This indicates the sector number of the first sector to be transferred. (L = 0) In LBA mode, this register contains LBA bits 0–7. (L = 1)
- Cylinder High/Low** This indicates the cylinder number of the first sector to be transferred. (L = 0) In LBA mode this register contains LBA bits 8–15 (Low) and bits 16–23 (High). (L = 1)
- H** This indicates the head number of the first sector to be transferred. (L = 0) In LBA mode this register contains LBA bits 24–27. (L = 1)

### **Input parameters from the device**

|                          |   |
|--------------------------|---|
| <b>Sector Count</b>      | This indicates the number of requested sectors not transferred. This number is zero unless an unrecoverable error occurs.   |
| <b>Sector Number</b>     | This indicates the sector number of the last transferred sector. (L = 0) In LBA mode, this register contains the current LBA bits 0–7. (L = 1)                                |
| <b>Cylinder High/Low</b> | This indicates the cylinder number of the last transferred sector. (L = 0) In LBA mode, this register contains the current LBA bits 8–15 (Low) and bits 16–23 (High). (L = 1) |
| <b>H</b>                 | This indicates the head number of the last transferred sector. (L = 0) In LBA mode this register contains the current LBA bits 24–27. (L = 1)                                 |

## 13.16 Read Native Max ADDRESS (F8h)

| Command Block Output Registers |   |   |   |   |   |   |   | Command Block Input Registers |               |           |   |   |   |   |   |   |   |
|--------------------------------|---|---|---|---|---|---|---|-------------------------------|---------------|-----------|---|---|---|---|---|---|---|
| Register                       | 7 | 6 | 5 | 4 | 3 | 2 | 1 | 0                             | Register      | 7         | 6 | 5 | 4 | 3 | 2 | 1 | 0 |
| Data                           | - | - | - | - | - | - | - | -                             | Data          | -         | - | - | - | - | - | - | - |
| Feature                        | - | - | - | - | - | - | - | -                             | Error         | see below |   |   |   |   |   |   |   |
| Sector Count                   | - | - | - | - | - | - | - | -                             | Sector Count  | -         | - | - | - | - | - | - | - |
| Sector Number                  | - | - | - | - | - | - | - | -                             | Sector Number | V         | V | V | V | V | V | V | V |
| Cylinder Low                   | - | - | - | - | - | - | - | -                             | Cylinder Low  | V         | V | V | V | V | V | V | V |
| Cylinder High                  | - | - | - | - | - | - | - | -                             | Cylinder High | V         | V | V | V | V | V | V | V |
| Device/Head                    | 1 | L | 1 | D | - | - | - | -                             | Device/Head   | -         | - | - | - | H | H | H | H |
| Command                        | 1 | 1 | 1 | 1 | 1 | 0 | 0 | 0                             | Status        | see below |   |   |   |   |   |   |   |

| Error Register |     |   |     |   |     |     |     |
|----------------|-----|---|-----|---|-----|-----|-----|
| 7              | 6   | 5 | 4   | 3 | 2   | 1   | 0   |
| CRC            | UNC | 0 | IDN | 0 | ABT | T0N | AMN |
| 0              | 0   | 0 | 0   | 0 | V   | 0   | 0   |

| Status Register |     |    |     |     |     |     |     |
|-----------------|-----|----|-----|-----|-----|-----|-----|
| 7               | 6   | 5  | 4   | 3   | 2   | 1   | 0   |
| BSY             | RDY | DF | DSC | DRQ | COR | IDX | ERR |
| 0               | V   | 0  | -   | -   | 0   | -   | V   |

Figure 101. Read Native Max ADDRESS (F8h)

This command returns the native max LBA/CYL of the drive which is not effected by the Set Max ADDRESS command. Even if the Address Offset mode is enabled, the native max LBA/CYL is returned.

### Output parameters to the device

- L** LBA mode. This indicates the addressing mode. L = 0 specifies CHS mode and L = 1 specifies the LBA addressing mode.
- D** This is the device number bit. Indicates that the device number bit of the Device/Head Register should be specified. D = 0 selects the master device and D = 1 selects the slave device.
- Indicates that the bit is not used.

### Input parameters from the device

- Sector Number** In LBA mode this register contains the native max LBA bits 0–7. (L = 1)  
In CHS mode this register contains the native max sector number. (L = 0)
- Cylinder High/Low** In LBA mode this register contains the native max LBA bits 8–15 (Low) and bits 16–23 (High). (L = 1)  
In CHS mode this register contains the native max cylinder number. (L = 0)
- H** In LBA mode this register contains the native max LBA bits 24–27. (L = 1) In CHS mode this register contains the native maximum head number. (L = 0)

- V** Valid. Indicates that the bit is part of an input parameter and will be set to 0 or 1 by the device.
- This indicates that the bit is not used.

## 13.17 Read Sectors (20h/21h)

| Command Block Output Registers |   |   |   |   |   |   |   | Command Block Input Registers |               |           |   |   |   |   |   |   |   |
|--------------------------------|---|---|---|---|---|---|---|-------------------------------|---------------|-----------|---|---|---|---|---|---|---|
| Register                       | 7 | 6 | 5 | 4 | 3 | 2 | 1 | 0                             | Register      | 7         | 6 | 5 | 4 | 3 | 2 | 1 | 0 |
| Data                           | - | - | - | - | - | - | - | -                             | Data          | -         | - | - | - | - | - | - | - |
| Feature                        | - | - | - | - | - | - | - | -                             | Error         | see below |   |   |   |   |   |   |   |
| Sector Count                   | V | V | V | V | V | V | V | V                             | Sector Count  | V         | V | V | V | V | V | V | V |
| Sector Number                  | V | V | V | V | V | V | V | V                             | Sector Number | V         | V | V | V | V | V | V | V |
| Cylinder Low                   | V | V | V | V | V | V | V | V                             | Cylinder Low  | V         | V | V | V | V | V | V | V |
| Cylinder High                  | V | V | V | V | V | V | V | V                             | Cylinder High | V         | V | V | V | V | V | V | V |
| Device/Head                    | 1 | L | 1 | D | H | H | H | H                             | Device/Head   | -         | - | - | - | H | H | H | H |
| Command                        | 0 | 0 | 1 | 0 | 0 | 0 | 0 | R                             | Status        | see below |   |   |   |   |   |   |   |

| Error Register |     |   |     |   |     |     |     |
|----------------|-----|---|-----|---|-----|-----|-----|
| 7              | 6   | 5 | 4   | 3 | 2   | 1   | 0   |
| CRC            | UNC | 0 | IDN | 0 | ABT | T0N | AMN |
| 0              | V   | 0 | V   | 0 | V   | 0   | V   |

| Status Register |     |    |     |     |     |     |     |
|-----------------|-----|----|-----|-----|-----|-----|-----|
| 7               | 6   | 5  | 4   | 3   | 2   | 1   | 0   |
| BSY             | RDY | DF | DSC | DRQ | COR | IDX | ERR |
| 0               | V   | 0  | V   | -   | 0   | -   | V   |

Figure 102. Read Sectors command (20h/21h)

The Read Sectors command reads one or more sectors of data from disk media and then transfers the data from the device to the host.

The sectors are transferred through the Data Register 16 bits at a time. If an uncorrectable error occurs the read will be terminated at the failing sector.

### Output parameters to the device

- Sector Count** This indicates the number of continuous sectors to be transferred. If zero is specified, then 256 sectors will be transferred.
- Sector Number** This is the sector number of the first sector to be transferred. (L = 0)  
In LBA mode this register contains the LBA bits 0–7. (L = 1)
- Cylinder High/Low** This is the cylinder number of the first sector to be transferred. (L = 0)  
In LBA mode this register contains the LBA bits 8–15 (Low) and bits 16–23 (High). (L = 1)
- H** This is the head number of the first sector to be transferred. (L = 0)  
In LBA mode this register contains the LBA bits 24–27. (L = 1)
- R** This is the retry bit, but this bit is ignored.

### **Input parameters from the device**

|                          |  |
|--------------------------|--|
| <b>Sector Count</b>      | This is the number of requested sectors not transferred. This will be zero, unless an unrecoverable error occurs.  |
| <b>Sector Number</b>     | This is the sector number of the last transferred sector. (L = 0)<br>In LBA mode this register contains the current LBA bits 0–7. (L = 1)                                |
| <b>Cylinder High/Low</b> | This is the cylinder number of the last transferred sector. (L = 0)<br>In LBA mode this register contains the current LBA bits 8–15 (Low) and bits 16–23 (High). (L = 1) |
| <b>H</b>                 | This is the head number of the last transferred sector. (L = 0)<br>In LBA mode this register contains the current LBA bits 24–27. (L = 1)                                |

## 13.18 Read Verify Sectors (40h/41h)

| Command Block Output Registers |   |   |   |   |   |   |   | Command Block Input Registers |               |           |   |   |   |   |   |   |   |
|--------------------------------|---|---|---|---|---|---|---|-------------------------------|---------------|-----------|---|---|---|---|---|---|---|
| Register                       | 7 | 6 | 5 | 4 | 3 | 2 | 1 | 0                             | Register      | 7         | 6 | 5 | 4 | 3 | 2 | 1 | 0 |
| Data                           | - | - | - | - | - | - | - | -                             | Data          | -         | - | - | - | - | - | - | - |
| Feature                        | - | - | - | - | - | - | - | -                             | Error         | see below |   |   |   |   |   |   |   |
| Sector Count                   | V | V | V | V | V | V | V | V                             | Sector Count  | V         | V | V | V | V | V | V | V |
| Sector Number                  | V | V | V | V | V | V | V | V                             | Sector Number | V         | V | V | V | V | V | V | V |
| Cylinder Low                   | V | V | V | V | V | V | V | V                             | Cylinder Low  | V         | V | V | V | V | V | V | V |
| Cylinder High                  | V | V | V | V | V | V | V | V                             | Cylinder High | V         | V | V | V | V | V | V | V |
| Device/Head                    | 1 | L | 1 | D | H | H | H | H                             | Device/Head   | -         | - | - | - | H | H | H | H |
| Command                        | 0 | 0 | 1 | 0 | 0 | 0 | 0 | R                             | Status        | see below |   |   |   |   |   |   |   |

| Error Register |     |   |     |   |     |     |     |
|----------------|-----|---|-----|---|-----|-----|-----|
| 7              | 6   | 5 | 4   | 3 | 2   | 1   | 0   |
| CRC            | UNC | 0 | IDN | 0 | ABT | T0N | AMN |
| 0              | V   | 0 | V   | 0 | V   | 0   | V   |

| Status Register |     |    |     |     |     |     |     |
|-----------------|-----|----|-----|-----|-----|-----|-----|
| 7               | 6   | 5  | 4   | 3   | 2   | 1   | 0   |
| BSY             | RDY | DF | DSC | DRQ | COR | IDX | ERR |
| 0               | V   | 0  | V   | -   | 0   | -   | V   |

Figure 103. Read Verify Sectors command (40h/41h)

The Read Verify Sectors command verifies one or more sectors on the device. No data is transferred to the host.

The difference between the Read Sectors command and Read Verify Sectors command is that data is transferred to the host during a Read Sectors command and data is not transferred to the host during a Read Verify Sectors command.

If an uncorrectable error occurs, the read verify will be terminated at the failing sector.

### Output parameters to the device

**Sector Count** This is the number of continuous sectors to be verified. If zero is specified, 256 sectors will be verified.

**Sector Number** This is the sector number of the first sector to be transferred. (L = 0)  
In LBA mode this register contains the LBA bits 0–7. (L = 1)

**Cylinder High/Low** This is the cylinder number of the first sector to be transferred. (L = 0)  
In LBA mode this register contains the LBA bits 8–15 (Low) and bits 16–23 (High). (L = 1)

**H** This is the head number of the first sector to be transferred. (L = 0)  
In LBA mode this register contains the LBA bits 24–27. (L = 1)

**R** This is the retry bit, but this bit is ignored.

### **Input parameters from the device**

|                          |  |
|--------------------------|--|
| <b>Sector Count</b>      | This is the number of requested sectors not verified. This number will be zero unless an unrecoverable error occurs.   |
| <b>Sector Number</b>     | This is the sector number of the last transferred sector. (L = 0)<br>In LBA mode this register contains the current LBA bits 0–7. (L = 1)                                |
| <b>Cylinder High/Low</b> | This is the cylinder number of the last transferred sector. (L = 0)<br>In LBA mode this register contains the current LBA bits 8–15 (Low) and bits 16–23 (High). (L = 1) |
| <b>H</b>                 | This is the head number of the last transferred sector. (L = 0)<br>In LBA mode this register contains the current LBA bits 24–27. (L = 1)                                |

## 13.19 Recalibrate (1xh)

| Command Block Output Registers |   |   |   |   |   |   |   | Command Block Input Registers |               |           |   |   |   |   |   |   |   |
|--------------------------------|---|---|---|---|---|---|---|-------------------------------|---------------|-----------|---|---|---|---|---|---|---|
| Register                       | 7 | 6 | 5 | 4 | 3 | 2 | 1 | 0                             | Register      | 7         | 6 | 5 | 4 | 3 | 2 | 1 | 0 |
| Data                           | - | - | - | - | - | - | - | -                             | Data          | -         | - | - | - | - | - | - | - |
| Feature                        | - | - | - | - | - | - | - | -                             | Error         | see below |   |   |   |   |   |   |   |
| Sector Count                   | - | - | - | - | - | - | - | -                             | Sector Count  | -         | - | - | - | - | - | - | - |
| Sector Number                  | - | - | - | - | - | - | - | -                             | Sector Number | -         | - | - | - | - | - | - | - |
| Cylinder Low                   | - | - | - | - | - | - | - | -                             | Cylinder Low  | -         | - | - | - | - | - | - | - |
| Cylinder High                  | - | - | - | - | - | - | - | -                             | Cylinder High | -         | - | - | - | - | - | - | - |
| Device/Head                    | 1 | - | 1 | D | - | - | - | -                             | Device/Head   | -         | - | - | - | - | - | - | - |
| Command                        | 0 | 0 | 0 | 1 | - | - | - | -                             | Status        | see below |   |   |   |   |   |   |   |

| Error Register |     |   |     |   |     |     |     |
|----------------|-----|---|-----|---|-----|-----|-----|
| 7              | 6   | 5 | 4   | 3 | 2   | 1   | 0   |
| CRC            | UNC | 0 | IDN | 0 | ABT | T0N | AMN |
| 0              | 0   | 0 | 0   | 0 | V   | V   | 0   |

| Status Register |     |    |     |     |     |     |     |
|-----------------|-----|----|-----|-----|-----|-----|-----|
| 7               | 6   | 5  | 4   | 3   | 2   | 1   | 0   |
| BSY             | RDY | DF | DSC | DRQ | COR | IDX | ERR |
| 0               | V   | 0  | V   | -   | 0   | -   | V   |

Figure 104. Recalibrate command (1xh)

The Recalibrate command moves the read/write heads from anywhere on the disk to cylinder 0.

If the device cannot reach cylinder 0, T0N (Track 0 Not Found) will be set in the Error Register.

## 13.20 Security Disable Password (F6h)

| Command Block Output Registers |   |   |   |   |   |   |   | Command Block Input Registers |               |           |   |   |   |   |   |   |   |
|--------------------------------|---|---|---|---|---|---|---|-------------------------------|---------------|-----------|---|---|---|---|---|---|---|
| Register                       | 7 | 6 | 5 | 4 | 3 | 2 | 1 | 0                             | Register      | 7         | 6 | 5 | 4 | 3 | 2 | 1 | 0 |
| Data                           | - | - | - | - | - | - | - | -                             | Data          | -         | - | - | - | - | - | - | - |
| Feature                        | - | - | - | - | - | - | - | -                             | Error         | see below |   |   |   |   |   |   |   |
| Sector Count                   | - | - | - | - | - | - | - | -                             | Sector Count  | -         | - | - | - | - | - | - | - |
| Sector Number                  | - | - | - | - | - | - | - | -                             | Sector Number | -         | - | - | - | - | - | - | - |
| Cylinder Low                   | - | - | - | - | - | - | - | -                             | Cylinder Low  | -         | - | - | - | - | - | - | - |
| Cylinder High                  | - | - | - | - | - | - | - | -                             | Cylinder High | -         | - | - | - | - | - | - | - |
| Device/Head                    | 1 | - | 1 | D | - | - | - | -                             | Device/Head   | -         | - | - | - | - | - | - | - |
| Command                        | 1 | 1 | 1 | 1 | 0 | 1 | 1 | 0                             | Status        | see below |   |   |   |   |   |   |   |

| Error Register |     |   |     |   |     |     |     |
|----------------|-----|---|-----|---|-----|-----|-----|
| 7              | 6   | 5 | 4   | 3 | 2   | 1   | 0   |
| CRC            | UNC | 0 | IDN | 0 | ABT | T0N | AMN |
| 0              | 0   | 0 | 0   | 0 | V   | 0   | 0   |

| Status Register |     |    |     |     |     |     |     |
|-----------------|-----|----|-----|-----|-----|-----|-----|
| 7               | 6   | 5  | 4   | 3   | 2   | 1   | 0   |
| BSY             | RDY | DF | DSC | DRQ | COR | IDX | ERR |
| 0               | V   | 0  | V   | -   | 0   | -   | V   |

Figure 105. Security Disable Password command (F6h)

The Security Disable Password command disables the security mode feature (device lock function).

The Security Disable Password command requests a transfer of a single sector of data from the host including information specified in Figure 106. The device then checks the transferred password. If the User Password or Master Password matches the given password, the device disables the security mode feature (device lock function). This command does not change the Master Password which may be reactivated later by setting User Password. This command should be executed in device unlock mode.

| Word   | Description   |
|--------|---|
| 00     | Control word<br>bit 0 : Identifier (1–Master, 0–User)<br>bits 1–15 : Reserved |
| 01–16  | Password (32 bytes)   |
| 17–255 | Reserved  |

Figure 106. Password Information for Security Disable Password command

The device will compare the password sent from this host with that specified in the control word.

**Identifier** Zero indicates that the device should check the supplied password against the user password stored internally. One indicates that the device should check the given password against the master password stored internally.

## 13.21 Security Erase Prepare (F3h)

| Command Block Output Registers |   |   |   |   |   |   |   | Command Block Input Registers |               |           |   |   |   |   |   |   |   |
|--------------------------------|---|---|---|---|---|---|---|-------------------------------|---------------|-----------|---|---|---|---|---|---|---|
| Register                       | 7 | 6 | 5 | 4 | 3 | 2 | 1 | 0                             | Register      | 7         | 6 | 5 | 4 | 3 | 2 | 1 | 0 |
| Data                           | - | - | - | - | - | - | - | -                             | Data          | -         | - | - | - | - | - | - | - |
| Feature                        | - | - | - | - | - | - | - | -                             | Error         | see below |   |   |   |   |   |   |   |
| Sector Count                   | - | - | - | - | - | - | - | -                             | Sector Count  | -         | - | - | - | - | - | - | - |
| Sector Number                  | - | - | - | - | - | - | - | -                             | Sector Number | -         | - | - | - | - | - | - | - |
| Cylinder Low                   | - | - | - | - | - | - | - | -                             | Cylinder Low  | -         | - | - | - | - | - | - | - |
| Cylinder High                  | - | - | - | - | - | - | - | -                             | Cylinder High | -         | - | - | - | - | - | - | - |
| Device/Head                    | 1 | - | 1 | D | - | - | - | -                             | Device/Head   | -         | - | - | - | - | - | - | - |
| Command                        | 1 | 1 | 1 | 1 | 0 | 0 | 1 | 1                             | Status        | see below |   |   |   |   |   |   |   |

| Error Register |     |   |     |   |     |     |     |
|----------------|-----|---|-----|---|-----|-----|-----|
| 7              | 6   | 5 | 4   | 3 | 2   | 1   | 0   |
| CRC            | UNC | 0 | IDN | 0 | ABT | T0N | AMN |
| 0              | 0   | 0 | 0   | 0 | V   | 0   | 0   |

| Status Register |     |    |     |     |     |     |     |
|-----------------|-----|----|-----|-----|-----|-----|-----|
| 7               | 6   | 5  | 4   | 3   | 2   | 1   | 0   |
| BSY             | RDY | DF | DSC | DRQ | COR | IDX | ERR |
| 0               | V   | 0  | V   | -   | 0   | -   | V   |

Figure 107. Security Erase Prepare command (F3h)

The Security Erase Prepare command must be issued immediately before the Security Erase Unit command to enable device erasing and unlocking.

The Security Erase Prepare Command must be issued immediately before the Format Unit Command. This command is to prevent accidental erasure of the device.

This command does not request the transfer of data.

## 13.22 Security Erase Unit (F4h)

| Command Block Output Registers |   |   |   |   |   |   |   | Command Block Input Registers |               |           |   |   |   |   |   |   |   |
|--------------------------------|---|---|---|---|---|---|---|-------------------------------|---------------|-----------|---|---|---|---|---|---|---|
| Register                       | 7 | 6 | 5 | 4 | 3 | 2 | 1 | 0                             | Register      | 7         | 6 | 5 | 4 | 3 | 2 | 1 | 0 |
| Data                           | - | - | - | - | - | - | - | -                             | Data          | -         | - | - | - | - | - | - | - |
| Feature                        | - | - | - | - | - | - | - | -                             | Error         | see below |   |   |   |   |   |   |   |
| Sector Count                   | - | - | - | - | - | - | - | -                             | Sector Count  | -         | - | - | - | - | - | - | - |
| Sector Number                  | - | - | - | - | - | - | - | -                             | Sector Number | -         | - | - | - | - | - | - | - |
| Cylinder Low                   | - | - | - | - | - | - | - | -                             | Cylinder Low  | -         | - | - | - | - | - | - | - |
| Cylinder High                  | - | - | - | - | - | - | - | -                             | Cylinder High | -         | - | - | - | - | - | - | - |
| Device/Head                    | 1 | - | 1 | D | - | - | - | -                             | Device/Head   | -         | - | - | - | - | - | - | - |
| Command                        | 1 | 1 | 1 | 1 | 0 | 1 | 0 | 0                             | Status        | see below |   |   |   |   |   |   |   |

| Error Register |     |   |     |   |     |     |     |
|----------------|-----|---|-----|---|-----|-----|-----|
| 7              | 6   | 5 | 4   | 3 | 2   | 1   | 0   |
| CRC            | UNC | 0 | IDN | 0 | ABT | T0N | AMN |
| 0              | 0   | 0 | V   | 0 | V   | 0   | 0   |

| Status Register |     |    |     |     |     |     |     |
|-----------------|-----|----|-----|-----|-----|-----|-----|
| 7               | 6   | 5  | 4   | 3   | 2   | 1   | 0   |
| BSY             | RDY | DF | DSC | DRQ | COR | IDX | ERR |
| 0               | V   | 0  | V   | -   | 0   | -   | V   |

Figure 108. Security Erase Unit command (F4h)

The Security Erase Unit command initializes all user data sectors and then disables the device lock function.

Note that the Security Erase Unit command initializes from LBA 0 to Native MAX LBA. The Host MAX LBA is set by the Initialize Drive Parameter or the Set MAX ADDRESS command is ignored. The protected area by the Set MAX ADDRESS command is also initialized.

This command requests the transfer of a single sector of data from the host including information specified in Figure 109.

If the password does not match, the device rejects the command with an Aborted error.

| Word   | Description  |
|--------|--|
| 00     | Control Word<br>bit 0 : Identifier (1- Master, 0- User)<br>bit 1-15 : Reserved |
| 01-16  | Password ( 32 bytes )  |
| 17-255 | Reserved   |

Figure 109. Erase Unit information

**Identifier** Zero indicates that the device should check the supplied password against the user password stored internally. One indicates that the device should check the given password against the master password stored internally.

The Security Erase Unit command erases all user data and disables the security mode feature (device lock function). After completing of this command, all the user data will be initialized to zero with a write operation. At this time, the data write is not verified with a read operation to determine if the data sector is initialized correctly. At this time the defective sector information and the reassigned sector information for the device are not updated. The security erase prepare command should be completed immediately prior to the Security Erase Unit command. If the device receives a Security Erase Unit command without a prior Security Erase Prepare command the device aborts the security erase unit command.

This command disables the security mode feature (device lock function), however, the master password is still stored internally within the device and may be reactivated later when a new user password is set. If you execute this command on disabling the security mode feature (device lock function), the password sent by the host is NOT compared with the Master Password and the User Password. The device only erases all user data.

The execution time of this command is shown below.

|                |        |
|----------------|--------|
| IC25T060ATCS05 | 60 min |
| IC25N040ATCS04 | 44 min |
| IC25N030ATCS04 | 34 min |
| IC25N020ATCS04 | 22 min |
| IC25N010ATCS04 | 12 min |

## 13.23 Security Freeze Lock (F5h)

| Command Block Output Registers |   |   |   |   |   |   |   | Command Block Input Registers |               |           |   |   |   |   |   |   |   |
|--------------------------------|---|---|---|---|---|---|---|-------------------------------|---------------|-----------|---|---|---|---|---|---|---|
| Register                       | 7 | 6 | 5 | 4 | 3 | 2 | 1 | 0                             | Register      | 7         | 6 | 5 | 4 | 3 | 2 | 1 | 0 |
| Data                           | - | - | - | - | - | - | - | -                             | Data          | -         | - | - | - | - | - | - | - |
| Feature                        | - | - | - | - | - | - | - | -                             | Error         | see below |   |   |   |   |   |   |   |
| Sector Count                   | - | - | - | - | - | - | - | -                             | Sector Count  | -         | - | - | - | - | - | - | - |
| Sector Number                  | - | - | - | - | - | - | - | -                             | Sector Number | -         | - | - | - | - | - | - | - |
| Cylinder Low                   | - | - | - | - | - | - | - | -                             | Cylinder Low  | -         | - | - | - | - | - | - | - |
| Cylinder High                  | - | - | - | - | - | - | - | -                             | Cylinder High | -         | - | - | - | - | - | - | - |
| Device/Head                    | 1 | - | 1 | D | - | - | - | -                             | Device/Head   | -         | - | - | - | - | - | - | - |
| Command                        | 1 | 1 | 1 | 1 | 0 | 1 | 0 | 1                             | Status        | see below |   |   |   |   |   |   |   |

| Error Register |     |   |     |   |     |     |     |
|----------------|-----|---|-----|---|-----|-----|-----|
| 7              | 6   | 5 | 4   | 3 | 2   | 1   | 0   |
| CRC            | UNC | 0 | IDN | 0 | ABT | T0N | AMN |
| 0              | 0   | 0 | 0   | 0 | V   | 0   | 0   |

| Status Register |     |    |     |     |     |     |     |
|-----------------|-----|----|-----|-----|-----|-----|-----|
| 7               | 6   | 5  | 4   | 3   | 2   | 1   | 0   |
| BSY             | RDY | DF | DSC | DRQ | COR | IDX | ERR |
| 0               | V   | 0  | -   | -   | 0   | -   | V   |

Figure 110. Security Freeze Lock command (F5h)

The Security Freeze Lock Command allows the device to enter frozen mode immediately.

After this command is completed, the command which updates Security Mode Feature (Device Lock Function) is rejected.

Frozen mode is quit only by a Power off.

The following commands are rejected when the device is in frozen mode. Refer to Figure 65 on page 90.

- Security Set Password
- Security Unlock
- Security Disable Password
- Security Erase Unit

## 13.24 Security Set Password (F1h)

| Command Block Output Registers |   |   |   |   |   |   |   | Command Block Input Registers |               |           |   |   |   |   |   |   |   |
|--------------------------------|---|---|---|---|---|---|---|-------------------------------|---------------|-----------|---|---|---|---|---|---|---|
| Register                       | 7 | 6 | 5 | 4 | 3 | 2 | 1 | 0                             | Register      | 7         | 6 | 5 | 4 | 3 | 2 | 1 | 0 |
| Data                           | - | - | - | - | - | - | - | -                             | Data          | -         | - | - | - | - | - | - | - |
| Feature                        | - | - | - | - | - | - | - | -                             | Error         | see below |   |   |   |   |   |   |   |
| Sector Count                   | - | - | - | - | - | - | - | -                             | Sector Count  | -         | - | - | - | - | - | - | - |
| Sector Number                  | - | - | - | - | - | - | - | -                             | Sector Number | -         | - | - | - | - | - | - | - |
| Cylinder Low                   | - | - | - | - | - | - | - | -                             | Cylinder Low  | -         | - | - | - | - | - | - | - |
| Cylinder High                  | - | - | - | - | - | - | - | -                             | Cylinder High | -         | - | - | - | - | - | - | - |
| Device/Head                    | 1 | - | 1 | D | - | - | - | -                             | Device/Head   | -         | - | - | - | - | - | - | - |
| Command                        | 1 | 1 | 1 | 1 | 0 | 0 | 0 | 1                             | Status        | see below |   |   |   |   |   |   |   |

| Error Register |     |   |     |   |     |     |     |
|----------------|-----|---|-----|---|-----|-----|-----|
| 7              | 6   | 5 | 4   | 3 | 2   | 1   | 0   |
| CRC            | UNC | 0 | IDN | 0 | ABT | T0N | AMN |
| 0              | 0   | 0 | 0   | 0 | V   | 0   | 0   |

| Status Register |     |    |     |     |     |     |     |
|-----------------|-----|----|-----|-----|-----|-----|-----|
| 7               | 6   | 5  | 4   | 3   | 2   | 1   | 0   |
| BSY             | RDY | DF | DSC | DRQ | COR | IDX | ERR |
| 0               | V   | 0  | -   | -   | 0   | -   | V   |

Figure 111. Security Set Password command (F1h)

The Security Set Password command enables the security mode feature (device lock function) and sets the master password or the user password.

The security mode feature (device lock function) is enabled by this command and the device is not locked immediately. The device is locked after the next power on reset or hard reset. When the MASTER password is set by this command, the master password is registered internally. The device is NOT locked after next power on reset or hard reset.

This command requests a transfer of a single sector of data from the host including the information specified in Figure 112 on page 154.

The data transferred controls the function of this command.

| Word   | Description  |
|--------|--|
| 00     | Control Word<br>bit 0 : Identifier (1-Master, 0-User)<br>bit 1-7 : Reserved<br>bit 8 : Security level (1-Maximum, 0-High)<br>bit 9-15 : Reserved |
| 01-16  | Password ( 32 bytes )  |
| 17-18  | Master Password Revision Code (valid if<br>Word 0 bit 0 = 1)   |
| 19-255 | Reserved   |

Figure 112. Security Set Password information

**Identifier** Zero indicates that the device should check the supplied password against the user password stored internally. One indicates that the device should check the given password against the master password stored internally.

**Security Level** A zero indicates a High level, a one indicates a Maximum level. If the host sets the High level and the password is forgotten then the Master Password can be used to unlock the device. If the host sets the Maximum level and the user password is forgotten, only a Security Erase Prepare/Security Unit command can unlock the device and all data will be lost.

**Password** The 32 bytes are always significant in the text of the password.

**Master Password Revision Code**

The Revision Code field is set with Master password. If Identifier is User, the Revision Code is not set. The Revision Code field is returned in Identify Device word 92. The valid Revision Codes are 0000h to FFFDh. The Default Master Password Revision Code is FFFEh. The code FFFFh is reserved.

The setting of the Identifier and Security level bits interact as follows:

**Identifier = User / Security level = High**

The password supplied with the command will be saved as the new user password. The security mode feature (lock function) will be enabled from the next power on. The drive may then be unlocked by either the user password or the previously set master password.

**Identifier = Master / Security level = High**

This combination will set a master password but will NOT enable the security mode feature (lock function).

**Identifier = User / Security level = Maximum**

The password supplied with the command will be saved as the new user password. The security mode feature (lock function) will be enabled from the next power on. The drive may then be unlocked by only the user password. The master password previously set is still stored in the drive but may NOT be used to unlock the device.

**Identifier = Master / Security level = Maximum**

This combination will set a master password but will NOT enable the security mode feature (lock function).

## 13.25 Security Unlock (F2h)

| Command Block Output Registers |   |   |   |   |   |   |   | Command Block Input Registers |               |           |   |   |   |   |   |   |   |
|--------------------------------|---|---|---|---|---|---|---|-------------------------------|---------------|-----------|---|---|---|---|---|---|---|
| Register                       | 7 | 6 | 5 | 4 | 3 | 2 | 1 | 0                             | Register      | 7         | 6 | 5 | 4 | 3 | 2 | 1 | 0 |
| Data                           | - | - | - | - | - | - | - | -                             | Data          | -         | - | - | - | - | - | - | - |
| Feature                        | - | - | - | - | - | - | - | -                             | Error         | see below |   |   |   |   |   |   |   |
| Sector Count                   | - | - | - | - | - | - | - | -                             | Sector Count  | -         | - | - | - | - | - | - | - |
| Sector Number                  | - | - | - | - | - | - | - | -                             | Sector Number | -         | - | - | - | - | - | - | - |
| Cylinder Low                   | - | - | - | - | - | - | - | -                             | Cylinder Low  | -         | - | - | - | - | - | - | - |
| Cylinder High                  | - | - | - | - | - | - | - | -                             | Cylinder High | -         | - | - | - | - | - | - | - |
| Device/Head                    | 1 | - | 1 | D | - | - | - | -                             | Device/Head   | -         | - | - | - | - | - | - | - |
| Command                        | 1 | 1 | 1 | 1 | 0 | 0 | 1 | 0                             | Status        | see below |   |   |   |   |   |   |   |

| Error Register |     |   |     |   |     |     |     |
|----------------|-----|---|-----|---|-----|-----|-----|
| 7              | 6   | 5 | 4   | 3 | 2   | 1   | 0   |
| CRC            | UNC | 0 | IDN | 0 | ABT | T0N | AMN |
| 0              | V   | 0 | 0   | 0 | V   | 0   | 0   |

| Status Register |     |    |     |     |     |     |     |
|-----------------|-----|----|-----|-----|-----|-----|-----|
| 7               | 6   | 5  | 4   | 3   | 2   | 1   | 0   |
| BSY             | RDY | DF | DSC | DRQ | COR | IDX | ERR |
| 0               | V   | 0  | -   | -   | 0   | -   | V   |

Figure 113. Security Unlock command (F2h)

This command unlocks the password and causes the device to enter device unlock mode. If a power on reset or hard reset is done without executing the Security Disable Password command after this command is completed, the device will be in device lock mode. The password has not been changed yet.

The Security Unlock command requests to transfer a single sector of data from the host including information specified in Figure 114 on page 156.

If the Identifier bit is set to master and the drive is in high security mode then the password supplied will be compared with the stored master password. If the drive is in maximum security mode then the security unlock will be rejected.

If the Identifier bit is set to user, then the drive compares the supplied password with the stored user password.

If the password compare fails then the device returns an abort error to the host and decrements the unlock attempt counter. This counter is initially set to 5 and is decremented for each password mismatch. When this counter reaches zero, all password protected commands are rejected until there is a hard reset or a power off.

| Word   | Description  |
|--------|--|
| 00     | Control Word<br>bit 0 : Identifier (1- Master, 0- User)<br>bit 1-15 : Reserved |
| 01-16  | Password ( 32 bytes )  |
| 17-255 | Reserved   |

Figure 114. Security Unlock information

**Identifier**                    A zero indicates that the device regards Password as the User Password. A one indicates that the device regards Password as the Master Password.

The user can detect if the attempt to unlock the device has failed due to a mismatched password since this is the only reason that an abort error will be returned by the drive AFTER the password information has been sent to the device. If an abort error is returned by the device BEFORE the password data has been sent to the drive, then another problem exists.

## 13.26 Seek (7xh)

| Command Block Output Registers |   |   |   |   |   |   |   | Command Block Input Registers |               |           |   |   |   |   |   |   |   |
|--------------------------------|---|---|---|---|---|---|---|-------------------------------|---------------|-----------|---|---|---|---|---|---|---|
| Register                       | 7 | 6 | 5 | 4 | 3 | 2 | 1 | 0                             | Register      | 7         | 6 | 5 | 4 | 3 | 2 | 1 | 0 |
| Data                           | - | - | - | - | - | - | - | -                             | Data          | -         | - | - | - | - | - | - | - |
| Feature                        | - | - | - | - | - | - | - | -                             | Error         | see below |   |   |   |   |   |   |   |
| Sector Count                   | - | - | - | - | - | - | - | -                             | Sector Count  | -         | - | - | - | - | - | - | - |
| Sector Number                  | V | V | V | V | V | V | V | V                             | Sector Number | V         | V | V | V | V | V | V | V |
| Cylinder Low                   | V | V | V | V | V | V | V | V                             | Cylinder Low  | V         | V | V | V | V | V | V | V |
| Cylinder High                  | V | V | V | V | V | V | V | V                             | Cylinder High | V         | V | V | V | V | V | V | V |
| Device/Head                    | 1 | L | 1 | D | H | H | H | H                             | Device/Head   | -         | - | - | - | H | H | H | H |
| Command                        | 0 | 1 | 1 | 1 | - | - | - | -                             | Status        | see below |   |   |   |   |   |   |   |

| Error Register |     |   |     |   |     |     |     |
|----------------|-----|---|-----|---|-----|-----|-----|
| 7              | 6   | 5 | 4   | 3 | 2   | 1   | 0   |
| CRC            | UNC | 0 | IDN | 0 | ABT | T0N | AMN |
| 0              | 0   | 0 | V   | 0 | V   | 0   | 0   |

| Status Register |     |    |     |     |     |     |     |
|-----------------|-----|----|-----|-----|-----|-----|-----|
| 7               | 6   | 5  | 4   | 3   | 2   | 1   | 0   |
| BSY             | RDY | DF | DSC | DRQ | COR | IDX | ERR |
| 0               | V   | 0  | V   | -   | 0   | -   | V   |

Figure 115. Seek command (7xh)

The Seek command initiates a seek to the designated track and selects the designated head. The device does not need to be formatted for a seek to execute properly.

### Output parameters to the device

**Sector Number** In LBA mode this register specifies the LBA address bits 0–7 for seek. (L = 1)

**Cylinder High/Low** This is the cylinder number of the seek. In LBA mode this register specifies the LBA address bits 8–15 (Low) and bits 16–23 (High) for seek. (L = 1)

**H** This indicates the head number of the seek. In LBA mode this register specifies the LBA address bits 24–27 for seek. (L = 1)

### Input parameters from the device

**Sector Number** In LBA mode this register contains the current LBA bits 0–7. (L = 1)

**Cylinder High/Low** In LBA mode this register contains the current LBA bits 8–15 (Low) and bits 16–23 (High). (L = 1)

**H** In LBA mode this register contains the current LBA bits 24–27. (L = 1)

## 13.27 Sense Condition (F0h: vendor specific)

| Command Block Output Registers |   |   |   |   |   |   |   | Command Block Input Registers |               |           |   |   |   |   |   |   |   |
|--------------------------------|---|---|---|---|---|---|---|-------------------------------|---------------|-----------|---|---|---|---|---|---|---|
| Register                       | 7 | 6 | 5 | 4 | 3 | 2 | 1 | 0                             | Register      | 7         | 6 | 5 | 4 | 3 | 2 | 1 | 0 |
| Data                           | - | - | - | - | - | - | - | -                             | Data          | -         | - | - | - | - | - | - | - |
| Feature                        | 0 | 0 | 0 | 0 | 0 | 0 | 0 | 1                             | Error         | see below |   |   |   |   |   |   |   |
| Sector Count                   | - | - | - | - | - | - | - | -                             | Sector Count  | V         | V | V | V | V | V | V | V |
| Sector Number                  | - | - | - | - | - | - | - | -                             | Sector Number | -         | - | - | - | - | - | - | N |
| Cylinder Low                   | - | - | - | - | - | - | - | -                             | Cylinder Low  | -         | - | - | - | - | - | - | - |
| Cylinder High                  | - | - | - | - | - | - | - | -                             | Cylinder High | -         | - | - | - | - | - | - | - |
| Device/Head                    | 1 | - | 1 | D | - | - | - | -                             | Device/Head   | -         | - | - | D | - | - | - | - |
| Command                        | 1 | 1 | 1 | 1 | 0 | 0 | 0 | 0                             | Status        | see below |   |   |   |   |   |   |   |

| Error Register |     |   |     |   |     |     |     |
|----------------|-----|---|-----|---|-----|-----|-----|
| 7              | 6   | 5 | 4   | 3 | 2   | 1   | 0   |
| CRC            | UNC | 0 | IDN | 0 | ABT | T0N | AMN |
| 0              | 0   | 0 | V   | 0 | V   | 0   | 0   |

| Status Register |     |    |     |     |     |     |     |
|-----------------|-----|----|-----|-----|-----|-----|-----|
| 7               | 6   | 5  | 4   | 3   | 2   | 1   | 0   |
| BSY             | RDY | DF | DSC | DRQ | COR | IDX | ERR |
| V               | V   | V  | -   | V   | -   | -   | V   |

Figure 116. Sense Condition Command (F0h)

The Sense Condition command is used to sense temperature in a device. This command is executable without spinning up even if a device is started with No Spin Up option. If this command is issued at the temperature out of range which is specified for operating condition, the error might be returned with IDN bit 1.

### Input parameters to the device

**Feature** The Feature register must be set to 01h. All other values are rejected with setting ABORT bit in status register.

### Input parameters from the device

**Sector Count** The Sector Count register contains result value.

#### Value Description

00h Temperature is equal to or lower than  $-20^{\circ}\text{C}$   
 01h–FEh Temperature is  $(\text{Value}/2 - 20)^{\circ}\text{C}$   
 FFh Temperature is higher than  $107^{\circ}\text{C}$

**N** Not recommendable condition for start up. If over stressed condition is detected, this bit will be set to one.

## 13.28 Set Features (EFh)

| Command Block Output Registers |            |   |   |   |   |   |   | Command Block Input Registers |               |           |   |   |   |   |   |   |   |
|--------------------------------|------------|---|---|---|---|---|---|-------------------------------|---------------|-----------|---|---|---|---|---|---|---|
| Register                       | 7          | 6 | 5 | 4 | 3 | 2 | 1 | 0                             | Register      | 7         | 6 | 5 | 4 | 3 | 2 | 1 | 0 |
| Data                           | -          | - | - | - | - | - | - | -                             | Data          | -         | - | - | - | - | - | - | - |
| Feature                        | V          | V | V | V | V | V | V | V                             | Error         | see below |   |   |   |   |   |   |   |
| Sector Count                   | see note 1 |   |   |   |   |   |   |                               | Sector Count  | -         | - | - | - | - | - | - | - |
| Sector Number                  | -          | - | - | - | - | - | - | -                             | Sector Number | -         | - | - | - | - | - | - | - |
| Cylinder Low                   | -          | - | - | - | - | - | - | -                             | Cylinder Low  | -         | - | - | - | - | - | - | - |
| Cylinder High                  | -          | - | - | - | - | - | - | -                             | Cylinder High | -         | - | - | - | - | - | - | - |
| Device/Head                    | 1          | - | 1 | D | - | - | - | -                             | Device/Head   | -         | - | - | - | - | - | - | - |
| Command                        | 1          | 1 | 1 | 0 | 1 | 1 | 1 | 1                             | Status        | see below |   |   |   |   |   |   |   |

| Error Register |     |   |     |   |     |     |     |
|----------------|-----|---|-----|---|-----|-----|-----|
| 7              | 6   | 5 | 4   | 3 | 2   | 1   | 0   |
| CRC            | UNC | 0 | IDN | 0 | ABT | T0N | AMN |
| 0              | 0   | 0 | 0   | 0 | V   | 0   | 0   |

| Status Register |     |    |     |     |     |     |     |
|-----------------|-----|----|-----|-----|-----|-----|-----|
| 7               | 6   | 5  | 4   | 3   | 2   | 1   | 0   |
| BSY             | RDY | DF | DSC | DRQ | COR | IDX | ERR |
| 0               | V   | 0  | -   | -   | 0   | -   | V   |

Figure 117. Set Features command (EFh)

The Set Feature command establishes the following parameters which affect the execution of certain features as shown in the table below.

ABT will be set to 1 in the Error Register if the Feature register contains any undefined values.

After the power on reset or hard reset the device is set to the following features as default.

|                                |         |
|--------------------------------|---------|
| Write cache                    | Enable  |
| ECC bytes                      | 4 bytes |
| Read look-ahead                | Enable  |
| Reverting to power on defaults | Disable |
| Address Offset mode            | Disable |

## Output parameters to the device

| Feature    | Destination code for this command.                        |
|------------|---|
| <b>02H</b> | Enable write cache (See note 2)                           |
| <b>03H</b> | Set transfer mode based on value in sector count register |
| <b>05H</b> | Enable Advanced Power Management                          |
| <b>09H</b> | Enable Address Offset mode                                |
| <b>44H</b> | 40 bytes of ECC apply on Read Long/Write Long commands    |
| <b>55H</b> | Disable read look-ahead feature                           |
| <b>66H</b> | Disable reverting to power on defaults                    |
| <b>82H</b> | Disable write cache                                       |
| <b>85H</b> | Disable Advanced Power Management (See note 3)            |
| <b>89H</b> | Disable Address Offset mode                               |
| <b>AAH</b> | Enable read look-ahead feature                            |
| <b>BBH</b> | 4 bytes of ECC apply on Read Long/Write Long commands     |
| <b>CCH</b> | Enable reverting to power on defaults                     |

*Note 1. When the Feature register is 03h (= Set Transfer mode) the Sector Count Register specifies the transfer mechanism. The upper 5 bits define the type of transfer and the low order 3 bits encode the mode value.*

|   |  |
|---|--|
| PIO Default Transfer Mode               | 00000 000                              |
| PIO Default Transfer Mode,Disable IORDY | 00000 001                              |
| PIO Flow Control Transfer Mode x        | 00001 nnn (nnn=000,001,010,011,100)    |
| Multiword DMA mode x                    | 00100 nnn (nnn=000,001,010)            |
| Ultra DMA mode x                        | 01000 nnn<br>(nnn=000,001,010,011,100) |

*When the Feature register is 05h (= Enable Advanced Power Management) the Sector Count Register specifies the Advanced Power Management level.*

|          |   |
|----------|---|
| C0h-FEh  | The deepest Power Saving mode is Active Idle    |
| 80h-BFh  | The deepest Power Saving mode is Low power Idle |
| 01h-7Fh  | The deepest Power Saving mode is Standby        |
| 00h, FFh | Aborted   |

*Note 2. If the number of auto reassigned sectors reaches the device's reassignment capacity, the write cache function will be automatically disabled. Although the device still accepts the Set Features command (with Feature register = 02h) without error, the write cache function will remain disabled. For the current write cache function status, refer to the Identify Device Information (129 word) by the Identify Device command.*

*Hard reset or power off must not be done during the first 5 seconds after write command completion when write cache is enabled.*

*Note 3. When the Feature register is 85h (= Disable Advanced Power Management) the deepest Power Saving mode becomes Active Idle.*

## 13.29 Set Max ADDRESS (F9h)

| Command Block Output Registers |   |   |   |   |   |   |   | Command Block Input Registers |               |           |   |   |   |   |   |   |   |
|--------------------------------|---|---|---|---|---|---|---|-------------------------------|---------------|-----------|---|---|---|---|---|---|---|
| Register                       | 7 | 6 | 5 | 4 | 3 | 2 | 1 | 0                             | Register      | 7         | 6 | 5 | 4 | 3 | 2 | 1 | 0 |
| Data                           | - | - | - | - | - | - | - | -                             | Data          | -         | - | - | - | - | - | - | - |
| Feature                        | V | V | V | V | V | V | V | V                             | Error         | see below |   |   |   |   |   |   |   |
| Sector Count                   | - | - | - | - | - | - | - | B                             | Sector Count  | -         | - | - | - | - | - | - | - |
| Sector Number                  | V | V | V | V | V | V | V | V                             | Sector Number | V         | V | V | V | V | V | V | V |
| Cylinder Low                   | V | V | V | V | V | V | V | V                             | Cylinder Low  | V         | V | V | V | V | V | V | V |
| Cylinder High                  | V | V | V | V | V | V | V | V                             | Cylinder High | V         | V | V | V | V | V | V | V |
| Device/Head                    | 1 | L | 1 | D | H | H | H | H                             | Device/Head   | -         | - | - | - | H | H | H | H |
| Command                        | 1 | 1 | 1 | 1 | 1 | 0 | 0 | 1                             | Status        | see below |   |   |   |   |   |   |   |

| Error Register |     |   |     |   |     |     |     |
|----------------|-----|---|-----|---|-----|-----|-----|
| 7              | 6   | 5 | 4   | 3 | 2   | 1   | 0   |
| CRC            | UNC | 0 | IDN | 0 | ABT | T0N | AMN |
| 0              | 0   | 0 | 0   | 0 | V   | 0   | 0   |

| Status Register |     |    |     |     |     |     |     |
|-----------------|-----|----|-----|-----|-----|-----|-----|
| 7               | 6   | 5  | 4   | 3   | 2   | 1   | 0   |
| BSY             | RDY | DF | DSC | DRQ | COR | IDX | ERR |
| 0               | V   | 0  | -   | -   | 0   | -   | V   |

Figure 118. Set Max ADDRESS (F9h)

The Set Max ADDRESS command overwrites the max LBA/CYL of the drive in a range of actual device capacities. Once the device receives this command, all accesses beyond that LBA/CYL are rejected by setting the ABORT bit in the status register. Identify the device command and Identify the device DMA command returns the LBA/CYL which is set via this command as a default value.

This command implement SET MAX security extension commands as subcommands. But regardless of Feature register value, the case this command is immediately preceded by a Read Native Max ADDRESS command, it is interpreted as a Set Max ADDRESS command.

The Read Native Max ADDRESS command should be issued and completed immediately prior to issuing the Set Max ADDRESS command. If it is not, this command is interpreted as a Set Max security extension command which is designated by feature register.

If Set Max security mode is in the Locked or Frozen, the Set Max ADDRESS command is aborted. For more information, see section 11.10.2, "Set Max security extension commands" on page 93.

In CHS mode, Cylinder High, Cylinder Low specify the maximum cylinder number. The Head number of DEVICE/HEAD and Sector Number are ignored. The default value (see default CHS in Identify device information) is used for that.

In LBA mode, the Head number of DEVICE/HEAD, the Cylinder High, the Cylinder Low, and the Sector Number specify the max LBA. This command will set this LBA as the max LBA of the device.

### Output parameters to the device

**Feature** Destination code for this command

**01h** SET MAX SET PASSWORD

**02h** SET MAX LOCK

**03h** SET MAX UNLOCK

**04h** SET MAX FREEZE LOCK

When the Set Max ADDRESS command is executed, this register is ignored.

**B** This indicates the option bit for selection whether nonvolatile or volatile. B = 0 is the volatile condition. When B = 1, MAX LBA/CYL—which is set by the Set Max ADDRESS command—is preserved by POR and HARD RESET. When B = 0, MAX LBA/CYL—which is set by Set Max ADDRESS command—will be lost by POR and HARD RESET. B = 1 is not valid when the device is in Address Offset mode and the command is aborted.

**Sector Number** In LBA mode this register contains LBA bits 0–7 which are to be input. (L = 1) In CHS mode this register is ignored. (L = 0)

**Cylinder High/Low** In LBA mode this register contains LBA bits 8–15 (Low) and bits 16–23 (High) which are to be set. (L = 1)

**H** In LBA mode this register contains LBA bits 24–27 which are to be input. (L = 1) In CHS mode this register is ignored. (L = 0)

**L** This indicates the LBA addressing mode. L = 0 specifies the CHS mode and L = 1 specifies the LBA addressing mode.

**D** This indicates the device number bit. The device number bit of the Device/Head should be specified. D = 0 selects the master device and D = 1 selects the slave device.

### Input parameters from the device

**Sector Number** In LBA mode this register contains the Adjusted max. LBA bits 0–7. (L = 1) In CHS mode this register contains the maximum sector number (= 63). (L = 0)

**Cylinder High/Low** In LBA mode this register contains the Adjusted max. LBA bits 8–15 (Low) and bits 16–23 (High). (L = 1)  
In CHS mode this register contains the max cylinder number which is set. (L = 0)

**H** In LBA mode this register contains the Adjusted max. LBA bits 24–27. (L = 1) In CHS mode this register contains the maximum head number (= 15). (L = 0)

## 13.30 Set Multiple (C6h)

| Command Block Output Registers |   |   |   |   |   |   |   | Command Block Input Registers |               |           |   |   |   |   |   |   |   |
|--------------------------------|---|---|---|---|---|---|---|-------------------------------|---------------|-----------|---|---|---|---|---|---|---|
| Register                       | 7 | 6 | 5 | 4 | 3 | 2 | 1 | 0                             | Register      | 7         | 6 | 5 | 4 | 3 | 2 | 1 | 0 |
| Data                           | - | - | - | - | - | - | - | -                             | Data          | -         | - | - | - | - | - | - | - |
| Feature                        | - | - | - | - | - | - | - | -                             | Error         | see below |   |   |   |   |   |   |   |
| Sector Count                   | V | V | V | V | V | V | V | V                             | Sector Count  | -         | - | - | - | - | - | - | - |
| Sector Number                  | - | - | - | - | - | - | - | -                             | Sector Number | -         | - | - | - | - | - | - | - |
| Cylinder Low                   | - | - | - | - | - | - | - | -                             | Cylinder Low  | -         | - | - | - | - | - | - | - |
| Cylinder High                  | - | - | - | - | - | - | - | -                             | Cylinder High | -         | - | - | - | - | - | - | - |
| Device/Head                    | 1 | - | 1 | D | - | - | - | -                             | Device/Head   | -         | - | - | - | - | - | - | - |
| Command                        | 1 | 1 | 0 | 0 | 0 | 1 | 1 | 0                             | Status        | see below |   |   |   |   |   |   |   |

| Error Register |     |   |     |   |     |     |     |
|----------------|-----|---|-----|---|-----|-----|-----|
| 7              | 6   | 5 | 4   | 3 | 2   | 1   | 0   |
| CRC            | UNC | 0 | IDN | 0 | ABT | T0N | AMN |
| 0              | 0   | 0 | 0   | 0 | V   | 0   | 0   |

| Status Register |     |    |     |     |     |     |     |
|-----------------|-----|----|-----|-----|-----|-----|-----|
| 7               | 6   | 5  | 4   | 3   | 2   | 1   | 0   |
| BSY             | RDY | DF | DSC | DRQ | COR | IDX | ERR |
| 0               | V   | 0  | -   | -   | 0   | -   | V   |

Figure 119. Set Multiple command (C6h)

The Set Multiple command enables the device to perform Read and Write Multiple commands and establishes the block size for these commands. The block size is the number of sectors to be transferred for each interrupt.

The default block size after power up or hard reset is 0. The Read Multiple and Write Multiple commands are disabled.

If an invalid block size is specified, an Abort error will be returned to the host. The Read Multiple and Write Multiple commands will be disabled.

### Output parameters to the device

**Sector Count.** This indicates the block size to be used for the Read Multiple and the Write Multiple commands. Valid block sizes can be selected from 0, 2, 4, 8 or 16. If 0 is specified, then the Read Multiple and the Write Multiple commands are disabled.

## 13.31 Sleep (E6h/99h)

| Command Block Output Registers |   |   |   |   |   |   |   | Command Block Input Registers |               |           |   |   |   |   |   |   |   |
|--------------------------------|---|---|---|---|---|---|---|-------------------------------|---------------|-----------|---|---|---|---|---|---|---|
| Register                       | 7 | 6 | 5 | 4 | 3 | 2 | 1 | 0                             | Register      | 7         | 6 | 5 | 4 | 3 | 2 | 1 | 0 |
| Data                           | - | - | - | - | - | - | - | -                             | Data          | -         | - | - | - | - | - | - | - |
| Feature                        | - | - | - | - | - | - | - | -                             | Error         | see below |   |   |   |   |   |   |   |
| Sector Count                   | - | - | - | - | - | - | - | -                             | Sector Count  | -         | - | - | - | - | - | - | - |
| Sector Number                  | - | - | - | - | - | - | - | -                             | Sector Number | -         | - | - | - | - | - | - | - |
| Cylinder Low                   | - | - | - | - | - | - | - | -                             | Cylinder Low  | -         | - | - | - | - | - | - | - |
| Cylinder High                  | - | - | - | - | - | - | - | -                             | Cylinder High | -         | - | - | - | - | - | - | - |
| Device/Head                    | 1 | - | 1 | D | - | - | - | -                             | Device/Head   | -         | - | - | - | - | - | - | - |
| Command                        | 1 | 1 | 1 | 0 | 0 | 1 | 1 | 0                             | Status        | see below |   |   |   |   |   |   |   |

| Error Register |     |   |     |   |     |     |     |
|----------------|-----|---|-----|---|-----|-----|-----|
| 7              | 6   | 5 | 4   | 3 | 2   | 1   | 0   |
| CRC            | UNC | 0 | IDN | 0 | ABT | TON | AMN |
| 0              | 0   | 0 | 0   | 0 | V   | 0   | 0   |

| Status Register |     |    |     |     |     |     |     |
|-----------------|-----|----|-----|-----|-----|-----|-----|
| 7               | 6   | 5  | 4   | 3   | 2   | 1   | 0   |
| BSY             | RDY | DF | DSC | DRQ | COR | IDX | ERR |
| 0               | V   | 0  | V   | -   | 0   | -   | V   |

Figure 120. Sleep command (E6h/99h)

This command is the only way to cause the device to enter Sleep Mode.

When this command is issued, the device confirms the completion of the cached write commands before it asserts INTRQ. Then the device is spun down, and the interface becomes inactive. The only way to recover from Sleep Mode is with a software reset or a hardware reset.

The use of hardware reset to recover from Sleep Mode may be incompatible with continued operation of the host system.

If the device is already spun down, the spin down sequence is not executed.

## 13.32 S.M.A.R.T. Function Set (B0h)

| Command Block Output Registers |   |   |   |   |   |   |   | Command Block Input Registers |               |           |   |   |   |   |   |   |   |
|--------------------------------|---|---|---|---|---|---|---|-------------------------------|---------------|-----------|---|---|---|---|---|---|---|
| Register                       | 7 | 6 | 5 | 4 | 3 | 2 | 1 | 0                             | Register      | 7         | 6 | 5 | 4 | 3 | 2 | 1 | 0 |
| Data                           | - | - | - | - | - | - | - | -                             | Data          | -         | - | - | - | - | - | - | - |
| Feature                        | V | V | V | V | V | V | V | V                             | Error         | see below |   |   |   |   |   |   |   |
| Sector Count                   | V | V | V | V | V | V | V | V                             | Sector Count  | -         | - | - | - | - | - | - | - |
| Sector Number                  | - | - | - | - | - | - | - | -                             | Sector Number | -         | - | - | - | - | - | - | - |
| Cylinder Low                   | 0 | 1 | 0 | 0 | 1 | 1 | 1 | 1                             | Cylinder Low  | -         | - | - | - | - | - | - | - |
| Cylinder High                  | 1 | 1 | 0 | 0 | 0 | 0 | 1 | 0                             | Cylinder High | -         | - | - | - | - | - | - | - |
| Device/Head                    | 1 | - | 1 | D | - | - | - | -                             | Device/Head   | -         | - | - | - | - | - | - | - |
| Command                        | 1 | 0 | 1 | 1 | 0 | 0 | 0 | 0                             | Status        | see below |   |   |   |   |   |   |   |

| Error Register |     |   |     |   |     |     |     |
|----------------|-----|---|-----|---|-----|-----|-----|
| 7              | 6   | 5 | 4   | 3 | 2   | 1   | 0   |
| CRC            | UNC | 0 | IDN | 0 | ABT | T0N | AMN |
| 0              | 0   | 0 | 0   | 0 | V   | 0   | 0   |

| Status Register |     |    |     |     |     |     |     |
|-----------------|-----|----|-----|-----|-----|-----|-----|
| 7               | 6   | 5  | 4   | 3   | 2   | 1   | 0   |
| BSY             | RDY | DF | DSC | DRQ | COR | IDX | ERR |
| 0               | V   | 0  | V   | -   | 0   | -   | V   |

Figure 121. S.M.A.R.T. Function Set command (B0h)

The S.M.A.R.T. Function Set command provides access to the Attribute Values, the Attribute Thresholds, and other low level subcommands that can be used for logging and reporting purposes and to accommodate special user needs. The S.M.A.R.T. Function Set command has several separate subcommands which are selectable via the device's Features Register when the S.M.A.R.T. Function Set command is issued by the host.

In order to select a subcommand the host must write the subcommand code to the device's Features Register before issuing the S.M.A.R.T. Function Set command. The subcommands and their respective codes are listed below.

| Code       | Subcommand                                   |
|------------|--|
| <b>D0h</b> | S.M.A.R.T. Read Attribute Values             |
| <b>D1h</b> | S.M.A.R.T. Read Attribute Thresholds         |
| <b>D2h</b> | S.M.A.R.T. Enable/disable Attribute Autosave |
| <b>D3h</b> | S.M.A.R.T. Save Attribute Values             |
| <b>D4h</b> | S.M.A.R.T. Execute Off-line Immediate        |
| <b>D5h</b> | S.M.A.R.T. Read Log Sector                   |
| <b>D6h</b> | S.M.A.R.T. Write Log Sector                  |
| <b>D8h</b> | S.M.A.R.T. Enable Operations                 |
| <b>D9h</b> | S.M.A.R.T. Disable Operations                |
| <b>DAh</b> | S.M.A.R.T. Return Status                     |
| <b>DBh</b> | S.M.A.R.T. Enable/Disable Automatic Off-line |

## **13.32.1 S.M.A.R.T. Function Subcommands**

### **13.32.1.1 S.M.A.R.T. Read Attribute Values (subcommand D0h)**

This subcommand returns the device's Attribute Values to the host. Upon receipt of the S.M.A.R.T. Read Attribute Values subcommand from the host, the device asserts BSY, saves any updated Attribute Values to the Attribute Data sectors, asserts DRQ, clears BSY, asserts INTRQ, and then waits for the host to transfer the 512 bytes of Attribute Value information from the device via the Data Register.

### **13.32.1.2 S.M.A.R.T. Read Attribute Thresholds (subcommand D1h)**

This subcommand returns the device's Attribute Thresholds to the host. Upon receipt of the S.M.A.R.T. Read Attribute Thresholds subcommand from the host, the device asserts BSY, reads the Attribute Thresholds from the Attribute Threshold sectors, asserts DRQ, clears BSY, asserts INTRQ, and then waits for the host to transfer the 512 bytes of Attribute Thresholds information from the device via the Data Register.

### **13.32.1.3 S.M.A.R.T. Enable/Disable Attribute Autosave (subcommand D2h)**

This subcommand enables and disables the attribute auto save feature of the device. The S.M.A.R.T. Enable/Disable Attribute Autosave subcommand allows the device to automatically save its updated Attribute Values to the Attribute Data Sector at the timing of the first transition to Active idle mode and after 30 minutes after the last saving of Attribute Values. This subcommand causes the auto save feature to be disabled. The state of the Attribute Autosave feature—either enabled or disabled—will be preserved by the device across the power cycle.

A value of 00h—written by the host into the device's Sector Count Register before issuing the S.M.A.R.T. Enable/Disable Attribute Autosave subcommand—will cause this feature to be disabled. Disabling this feature does not preclude the device from saving Attribute Values to the Attribute Data sectors during some other normal operation such as during a power-up or a power-down.

A value of F1h—written by the host into the device's Sector Count Register before issuing the S.M.A.R.T. Enable/Disable Attribute Autosave subcommand—will cause this feature to be enabled. Any other nonzero value written by the host into this register before issuing the S.M.A.R.T. Enable/Disable Attribute Autosave subcommand will not change the current Autosave status. The device will respond with the error code specified in Figure 133 on page 181.

The S.M.A.R.T. Disable Operations subcommand disables the auto save feature along with the device's S.M.A.R.T. operations.

Upon the receipt of the subcommand from the host, the device asserts BSY, enables or disables the Autosave feature, clears BSY, and asserts INTRQ.

### **13.32.1.4 S.M.A.R.T. Save Attribute Values (subcommand D3h)**

This subcommand causes the device to immediately save any updated Attribute Values to the device's Attribute Data sector regardless of the state of the Attribute Autosave feature. Upon receipt of the S.M.A.R.T. Save Attribute Values subcommand from the host, the device asserts BSY, writes any updated Attribute Values to the Attribute Data sector, clears BSY, and asserts INTRQ.

### 13.32.1.5 S.M.A.R.T. Execute Off-line Immediate (subcommand D4h)

This subcommand causes the device to immediately initiate the set of activities that collect Attribute data in an off-line mode (off-line routine) or execute a self-test routine in either captive or off-line mode. The Sector Number register shall be set to specify the operation to be executed.

| Sector Number | Operation to be executed   |
|---------------|--|
| 0             | Execute S.M.A.R.T. off-line data collection routine immediately            |
| 1             | Execute S.M.A.R.T. Short self-test routine immediately in off-line mode    |
| 2             | Execute S.M.A.R.T. Extended self-test routine immediately in off-line mode |
| 127           | Abort off-line mode self-test routine                                      |
| 129           | Execute S.M.A.R.T. Short self-test routine immediately in captive mode     |
| 130           | Execute S.M.A.R.T. Extended self-test routine immediately in captive mode  |

**Off-line mode:** The device executes command completion before executing the specified routine. During execution of the routine the device will not set BSY nor clear DRDY. If the device is in the process of performing its routine and is interrupted by a new command from the host, the device will abort or suspend its routine and service the host within two seconds after receipt of the new command. After servicing the interrupting command, the device will resume its routine automatically or not start its routine depending on the interrupting command.

**Captive mode:** When executing self-test in captive mode, the device sets BSY to one and executes the specified self-test routine after receipt of the command. At the end of the routine, the device sets the execution result in the Self-test execution status byte (Figure 123 on page 170) and ATA registers—see definitions below—and then executes the command completion.

|                 |   |
|-----------------|---|
| <b>Status</b>   | Set ERR to one when the self-test has failed  |
| <b>Error</b>    | Set ABRT to one when the self-test has failed |
| <b>Cyl Low</b>  | Set to F4h when the self-test has failed      |
| <b>Cyl High</b> | Set to 2Ch when the self-test has failed      |

### 13.32.1.6 S.M.A.R.T. Read Log Sector (subcommand D5h)

This command returns the specified log sector contents to the host.

The 512 bytes of data are returned at a command and the Sector Count value shall be set to one. The Sector Number shall be set to specify the log sector address.

| Log sector address | Content                  | Type       |
|--------------------|--------------------------|------------|
| 01h                | S.M.A.R.T. Error Log     | Read Only  |
| 06h                | S.M.A.R.T. Self-test Log | Read Only  |
| 80h-9Fh            | Host vendor specific     | Read/Write |

Figure 122. Log sector addresses

### 13.32.1.7 S.M.A.R.T. Write Log Sector (subcommand D6h)

This command writes 512 bytes of data to the specified log sector.

The 512 bytes of data are transferred at a command and the Sector Count value shall be set to one. The Sector Number shall be set to specify the log sector address (Figure 121). If a Read Only log sector is specified, the device returns ABRT error.

### **13.32.1.8 S.M.A.R.T. Enable Operations (subcommand D8h)**

This subcommand enables access to all S.M.A.R.T. capabilities within the device. Prior to receipt of a S.M.A.R.T. Enable Operations subcommand, Attribute Values are neither monitored nor saved by the device. The state of S.M.A.R.T.—either enabled or disabled—will be preserved by the device across power cycles. Once enabled, the receipt of subsequent S.M.A.R.T. Enable Operations subcommands will not affect any of the Attribute Values.

Upon receipt of the S.M.A.R.T. Enable Operations subcommand from the host, the device asserts BSY, enables S.M.A.R.T. capabilities and functions, clears BSY, and asserts INTRQ.

### **13.32.1.9 S.M.A.R.T. Disable Operations (subcommand D9h)**

This subcommand disables all S.M.A.R.T. capabilities within the device including the device's attribute auto save feature. After receipt of this subcommand the device disables all S.M.A.R.T. operations. Non self-preserved Attribute Values will no longer be monitored. The state of S.M.A.R.T.—either enabled or disabled—is preserved by the device across power cycles. Note that this subcommand does not preclude the device's power mode attribute auto saving.

Upon receipt of the S.M.A.R.T. Disable Operations subcommand from the host, the device asserts BSY, disables S.M.A.R.T. capabilities and functions, clears BSY, and asserts INTRQ.

After receipt of the device of the S.M.A.R.T. Disable Operations subcommand from the host, all other S.M.A.R.T. subcommands—with the exception of S.M.A.R.T. Enable Operations—are disabled, and invalid and will be aborted by the device—including the S.M.A.R.T. Disable Operations subcommand—returning the error code as specified in Figure 133 on page 181.

Any Attribute Values accumulated and saved to volatile memory prior to receipt of the S.M.A.R.T. Disable Operations command will be preserved in the device's Attribute Data Sectors. If the device is re-enabled, these Attribute Values will be updated, as needed, upon receipt of a S.M.A.R.T. Read Attribute Values or a S.M.A.R.T. Save Attribute Values command.

### **13.32.1.10 S.M.A.R.T. Return Status (subcommand DAh)**

This subcommand is used to communicate the reliability status of the device to the host's request. Upon receipt of the S.M.A.R.T. Return Status subcommand the device asserts BSY, saves any updated Attribute Values to the reserved sector, and compares the updated Attribute Values to the Attribute Thresholds.

If the device does not detect a Threshold Exceeded Condition, or detects a Threshold Exceeded Condition but involving attributes are advisory, the device loads 4Fh into the Cylinder Low register, C2h into the Cylinder High register, clears BSY, and asserts INTRQ.

If the device detects a Threshold Exceeded Condition for prefailure attributes, the device loads F4h into the Cylinder Low register, 2Ch into the Cylinder High register, clears BSY, and asserts INTRQ. Advisory attributes never result in a negative reliability condition.

### **13.32.1.11 S.M.A.R.T. Enable/Disable Automatic Off-line (subcommand DBh)**

This subcommand enables and disables the optional feature that cause the device to perform the set of off-line data collection activities that automatically collect attribute data in an off-line mode and then save this data to the device's nonvolatile memory. This subcommand may either cause the device to automatically initiate or resume performance of its off-line data collection activities or cause the automatic off-line data collection feature to be disabled. This subcommand also enables and disables the off-line read scanning feature that cause the device to perform the entire read scanning with defect reallocation as the part of the off-line data collection activities.

The Sector Count register shall be set to specify the feature to be enabled or disabled:

| <b>Sector Count</b> | <b>Feature Description</b>     |
|---------------------|--------------------------------|
| 00h                 | Disable Automatic Off-line     |
| 01h                 | Disable Off-line Read Scanning |
| F8h                 | Enable Automatic Off-line      |
| F9h                 | Enable Off-line Read Scanning  |

A value of zero written by the host into the device's Sector Count register before issuing this subcommand shall cause the automatic off-line data collection feature to be disabled. Disabling this feature does not preclude the device from saving attribute values to nonvolatile memory during some other normal operation such as during a power-on, during a power-off sequence, or during an error recovery sequence.

A value of one written by the host into the device's Sector Count register before issuing this subcommand shall cause the off-line read scanning feature to be disabled. The Device does not perform the off-line read scanning at the off-line data collection activities which is initiated by the S.M.A.R.T. Execute Off-line Immediate (Subcommand D4h) or automatically if the off-line read scanning feature is disabled.

A value of F8h written by the host into the device's Sector Count register before issuing this subcommand shall cause the automatic Off-line data collection feature to be enabled.

A value of F9 written by the host into the device's Sector Count register before issuing this subcommand shall cause the off-line read scanning feature to be enabled. The Device perform the off-line read scanning at the off-line data collection activities which is initiated by the S.M.A.R.T. Execute Off-line Immediate (Subcommand D4h) even if the automatic off-line feature is disabled.

Any other nonzero value written by the host into this register before issuing this subcommand is vendor specific and will not change the current Automatic Off-Line Data Collection and Off-line Read Scanning status. However, the device may respond with the error code specified in Figure 133 on page 181.

## 13.32.2 Device Attributes Data Structure

The following defines the 512 bytes that make up the Attribute Value information. This data structure is accessed by the host in its entirety using the S.M.A.R.T. Read Attribute Values subcommand. All multibyte fields shown in these data structures follow the ATA/ATAPI-5 specification for byte ordering, namely, that the least significant byte occupies the lowest numbered byte address location in the field.

| Description   | Byte | Offset | Format | Value |
|---|------|--------|--------|-------|
| Data Structure Revision Number                                      | 2    | 00h    | binary | 0010h |
| 1st Device Attribute  | 12   | 02h    | (*1)   | (*2)  |
| ↑   | ↑    | ↑      | ↑      | ↑     |
| 30th Device Attribute   | 12   | 15Eh   | (*1)   | (*2)  |
| Off-line data collection status                                     | 1    | 16Ah   | (*1)   | (*2)  |
| Self-test execution status  | 1    | 16Bh   | (*1)   | (*2)  |
| Total time in seconds to complete off-line data collection activity | 2    | 16Ch   | (*1)   | (*2)  |
| Current segment pointer   | 1    | 16Eh   | (*1)   | (*2)  |
| Off-line data collection capability                                 | 1    | 16Fh   | (*1)   | 1Bh   |
| S.M.A.R.T. capability   | 2    | 170h   | (*1)   | 0003h |
| S.M.A.R.T. device error logging capability                          | 1    | 172h   | (*1)   | 01h   |
| Self-test failure check point                                       | 1    | 173h   | (*1)   | (*2)  |
| Short self-test completion time in minutes                          | 1    | 174h   | (*1)   | (*2)  |
| Extended self-test completion time in minutes                       | 1    | 175h   | (*1)   | (*2)  |
| Reserved  | 12   | 176h   |        | (*3)  |
| Vendor specific   | 125  | 182h   |        | (*3)  |
| Data structure checksum   | 1    | 1FFh   | (*1)   | (*2)  |
|   | 512  |        |        |       |

(\*1) – See following definitions

(\*2) – This value varies due to actual operating condition.

(\*3) – Filled with 00h.

Figure 123. Device Attribute Data Structure

### 13.32.2.1 Data Structure Revision Number

The Data Structure Revision Number identifies which version of this data structure is implemented by the device. This revision number will be set to 0005h. This revision number identifies both the Attribute Value and Attribute Threshold Data structures.

### 13.32.2.2 Individual Attribute Data Structure

The following defines the 12 bytes that make up the information for each Attribute entry in the Device Attribute Data Structure.

| Description   | Byte | Offset | Value     |
|---|------|--------|-----------|
| Attribute ID Number (01h to FFh)                                  | 1    | 00h    | binary    |
| Status Flags  | 2    | 01h    | bit flags |
| Bit 0    Pre-Failure/Advisory                                     |      |        |           |
| Bit 1    On-line Collection                                       |      |        |           |
| Bit 2-5  Reserved (may be either 0 or 1)                          |      |        |           |
| Bit 6-15 Reserved (all 0)   |      |        |           |
| Attribute Value (valid values from 01h to FEh)                    | 1    | 03h    | binary    |
| 00h invalid for attribute value -not to be used                   |      |        |           |
| 01h minimum value   |      |        |           |
| 64h initial value for all attributes prior to any data collection |      |        |           |
| FDh maximum value   |      |        |           |
| FEh value is not valid  |      |        |           |
| FFh invalid for attribute value-not to be used                    |      |        |           |
| Reserved (may not be 0)   | 1    | 04h    | binary    |
| Reserved (may not be 0)   | 6    | 05h    | binary    |
| Reserved (00h)  | 1    | 0Bh    | binary    |
| Total Bytes   | 12   |        |           |

Figure 124. Individual Attribute Data Structure

**Attribute ID Numbers:** Any nonzero value in the Attribute ID Number indicates an active attribute. The device supports following Attribute ID Numbers. The names marked with (\*) indicate that the corresponding Attribute Values can be either collected on-line or off-line.

| ID  | Attribute Name  |
|-----|---|
| 0   | Indicates that this entry in the data structure is not used |
| 1   | Raw Read Error Rate (*)                                     |
| 2   | Throughput Performance (*)                                  |
| 3   | Spin Up Time  |
| 4   | Start/Stop Count  |
| 5   | Reallocated Sector Count                                    |
| 7   | Seek Error Rate   |
| 8   | Seek Time Performance (*)                                   |
| 9   | Power-On Hours Count  |
| 10  | Spin Retry Count  |
| 12  | Device Power Cycle Count                                    |
| 191 | Gsense Error Rate   |
| 192 | Power Off Retract Count                                     |
| 193 | Load/Unload Cycle Count                                     |
| 194 | Device Temperature  |

- 196**      Reallocation Event Count
- 197**      Current Pending Sector Count
- 198**      Off-Line Scan Uncorrectable Sector Count
- 199**      Ultra DMA CRC Error Count

**Status Flag definitions:**

| Bit  | Flag Name                    | Definition  |
|------|------------------------------|---|
| 0    | Pre-Failure/<br>Advisory bit | If bit = 0, an Attribute Value less than or equal to its corresponding Attribute Threshold indicates an Advisory condition where the usage or age of the device has exceeded its intended design life period.<br>If bit = 1, an Attribute Value less than or equal to its corresponding Attribute Threshold indicates a Pre-Failure condition where imminent loss of data is being predicted. |
| 1    | On-Line<br>Collective bit    | If bit = 0, the Attribute Value is updated only during Off-Line testing.<br>If bit = 1, the Attribute Value is updated during On-Line testing or during both On-Line and Off-Line testing.  |
| 2-5  | Reserved bits                | May either be 0 or 1  |
| 6-15 | Reserved bits                | Always 0  |

Figure 125. Status Flag definitions

**Normalized values:** The device will perform conversion of the raw Attribute Values to transform them into normalized values which the host can then compare with the Threshold values. A Threshold is the excursion limit for a normalized Attribute Value. In normalizing the raw data, the device will perform any necessary statistical validity checks to ensure that an instantaneous raw value is not improperly reflected in the normalized Attribute Value (i.e., one read error in the first 10 reads being interpreted as exceeding the read error rate threshold when the subsequent 1 billion reads all execute without error). The end points for the normalized values for all Attributes will be 1 (01h) at the low end and 100 (64h) at the high end for the device. For Performance and Error Rate Attributes, values greater than 100 are also possible. The maximum value possible is 253 (FDh).

**13.32.2.3 Off-Line Data Collection Status**

The value of this byte defines the current status of the off-line activities of the device. Bit 7 indicates an Automatic Off-line Data Collection Status.

- Bit 7            Automatic Off-line Data Collection Status**
- 0**            Automatic Off-line Data Collection is disabled.
  - 1**            Automatic Off-line Data Collection is enabled.

Bits 0–6 represent a hexadecimal status value reported by the device.

- | <b>Value</b> | <b>Definition</b>                       |
|--------------|---|
| <b>0</b>     | Off-line data collection never started. |

- 2 All segments completed without errors. In this case the current segment pointer is equal to the total segments required.
- 4 Off-line data collection is suspended by the interrupting command.
- 5 Off-line data collecting is aborted by the interrupting command.
- 6 Off-line data collection is aborted with a fatal error.

### 13.32.2.4 Self-test execution status

| <b>Bit</b> | <b>Definition</b>   |
|------------|---|
| 0-3        | Percent Self-test remaining. An approximation of the percent of the self-test routine remaining until completion given in ten percent increments. Valid values are 0 through 9. |
| 4-7        | Current Self-test execution status.   |
| 0          | The self-test routine completed without error or has never been run.  |
| 1          | The self-test routine was aborted by the host.  |
| 2          | The self-test routine was interrupted by the host with a hard or soft reset.  |
| 3          | The device was unable to complete the self-test routine due to a fatal error or unknown test error.   |
| 4          | The self-test routine was completed with an unknown element failure.  |
| 5          | The self-test routine was completed with an electrical element failure.   |
| 6          | The self-test routine was completed with a servo element failure.   |
| 7          | The self-test routine was completed with a read element failure.  |
| 15         | The self-test routine is in progress.   |

### 13.32.2.5 Total time in seconds to complete off-line data collection activity

This field tells the host how many seconds the device requires to complete the off-line data collection activity.

### 13.32.2.6 Current segment pointer

This byte is a counter indicating the next segment to execute as an off-line data collection activity. Because the number of segments is 1, 01h is always returned in this field.

### 13.32.2.7 Off-line data collection capability

#### Bit Definition

- 0 Execute Off-line Immediate implemented bit
  - 0 S.M.A.R.T. Execute Off-line Immediate subcommand is not implemented
  - 1 S.M.A.R.T. Execute Off-line Immediate subcommand is implemented
- 1 Enable/disable Automatic Off-line implemented bit
  - 0 S.M.A.R.T. Enable/disable Automatic Off-line subcommand is not implemented
  - 1 S.M.A.R.T. Enable/disable Automatic Off-line subcommand is implemented

- 2** Abort/restart off-line by host bit
  - 0** The device will suspend off-line data collection activity after an interrupting command and resume it after a vendor specific event
  - 1** The device will abort off-line data collection activity upon receipt of a new command
- 3** Off-line Read Scanning implemented bit
  - 0** The device does not support Off-line Read Scanning
  - 1** The device supports Off-line Read Scanning
- 4** Self-test implemented bit
  - 0** Self-test routine is not implemented
  - 1** Self-test routine is implemented
- 5-7** Reserved (0)

### 13.32.2.8 S.M.A.R.T. Capability

This word of bit flags describes the S.M.A.R.T. capabilities of the device. The device will return 03h indicating that the device will save its Attribute Values prior to going into a power saving mode and supports the S.M.A.R.T. ENABLE/DISABLE ATTRIBUTE AUTOSAVE command.

#### Bit Definition

- 0** Pre-power mode attribute saving capability. If bit = 1, the device will save its Attribute Values prior to going into a power saving mode (Standby or Sleep mode).
- 1** Attribute auto save capability. If bit = 1, the device supports the S.M.A.R.T. ENABLE/DISABLE ATTRIBUTE AUTOSAVE command.
- 2-15** Reserved (0)

### 13.32.2.9 Error logging capability

#### Bit Definition

- 7-1** Reserved (0)
- 0** The Error Logging support bit. If bit = 1, the device supports the Error Logging

### 13.32.2.10 Self-test failure check point

This byte indicates the section of self-test where the device detected a failure.

### 13.32.2.11 Self-test completion time

These bytes are the minimum time in minutes to complete the self-test.

### 13.32.2.12 Data Structure Checksum

The Data Structure Checksum is the 2's complement of the result of a simple 8-bit addition of the first 511 bytes in the data structure.

### 13.32.3 Device Attribute Thresholds data structure

The following defines the 512 bytes that make up the Attribute Threshold information. This data structure is accessed by the host in its entirety using the S.M.A.R.T. Read Attribute Thresholds. All multibyte fields shown in these data structures follow the ATA/ATAPI-5 specification for byte ordering, that is, that the least significant byte occupies the lowest numbered byte address location in the field.

The sequence of active Attribute Thresholds will appear in the same order as their corresponding Attribute Values.

---

| Description                    | Byte | Offset | Format | Value |
|--------------------------------|------|--------|--------|-------|
| Data Structure Revision Number | 2    | 00h    | binary | 0010h |
| 1st Device Attribute           | 12   | 02h    | (*1)   | (*2)  |
| ...                            | ..   |        |        |       |
| ...                            | ..   |        |        |       |
| 30th Device Attribute          | 12   | 15Eh   | (*1)   | (*2)  |
| Reserved                       | 18   | 16Ah   |        | (*3)  |
| Vendor specific                | 131  | 17Ch   |        | (*3)  |
| Data structure checksum        | 1    | 1FFh   |        | (*2)  |
|                                | 512  |        |        |       |

(\*1) - See the following definitions

(\*2) - Value varies by actual operating condition

(\*3) - Filled with 00h

---

Figure 126. Device Attribute Thresholds Data Structure

#### 13.32.3.1 Data Structure Revision Number

This value is the same as the value used in the Device Attributes Values Data Structure.

### 13.32.3.2 Individual Thresholds Data Structure

The following defines the 12 bytes that make up the information for each Threshold entry in the Device Attribute Thresholds Data Structure. Attribute entries in the Individual Threshold Data Structure are in the same order and correspond to the entries in the Individual Attribute Data Structure.

---

| Description  | Byte | Offset | Format |
|--|------|--------|--------|
| Attribute ID Number (01h to FFh)   | 1    | 00h    | binary |
| Attribute Threshold (for comparison with Attribute Values from 00h to FFh) | 1    | 01h    | binary |
| 00h – "always passing" threshold value to be used for code test purposes   |      |        |        |
| 01h – minimum value for normal operation                                   |      |        |        |
| FDh – maximum value for normal operation                                   |      |        |        |
| FEh – invalid for threshold value  |      |        |        |
| FFh – "always failing" threshold value to be used for code test purposes   |      |        |        |
| Reserved (00h)   | 10   | 02h    | binary |
| Total Bytes  | 12   |        |        |

---

Figure 127. Individual Threshold Data Structure

### 13.32.3.3 Attribute ID Numbers

Attribute ID Numbers supported by the device are the same as Attribute Values Data Structures.

### 13.32.3.4 Attribute Threshold

These values are preset at the factory and are not meant to be changeable. However, the host might use the "S.M.A.R.T. Write Attribute Threshold" subcommand to override these preset values in the Threshold sectors.

### 13.32.3.5 Data Structure Checksum

The Data Structure Checksum is the 2's compliment of the result of a simple 8-bit addition of the first 511 bytes in the data structure.

## 13.32.4 S.M.A.R.T. error log sector

The following defines the 512 bytes that make up the S.M.A.R.T. error log sector. All multibyte fields shown in these data structures follow the ATA/ATAPI-5 specifications for byte ordering.

---

| Description                  | Byte | Offset |
|------------------------------|------|--------|
| S.M.A.R.T. error log version | 1    | 00h    |
| Error log pointer            | 1    | 01h    |
| 1st error log data structure | 90   | 02h    |
| 2nd error log data structure | 90   | 5Ch    |
| 3rd error log data structure | 90   | B6h    |
| 4th error log data structure | 90   | 110h   |
| 5th error log data structure | 90   | 16Ah   |
| Device error count           | 2    | 1C4h   |
| Reserved                     | 57   | 1C6h   |
| Data structure checksum      | 1    | 1FFh   |
|                              | 512  |        |

---

Figure 128. S.M.A.R.T. error log sector

### 13.32.4.1 S.M.A.R.T. error log version

This value is set to 01h.

### 13.32.4.2 Error log pointer

This points to the most recent error log data structure. Only values 1 through 5 are valid.

### 13.32.4.3 Device error count

This field contains the total number of errors. The value will not roll over.

### 13.32.4.4 Error log data structure

The data format of each error log structure is shown below.

---

| Description                | Byte | Offset |
|----------------------------|------|--------|
| 1st command data structure | 12   | 00h    |
| 2nd command data structure | 12   | 0Ch    |
| 3rd command data structure | 12   | 18h    |
| 4th command data structure | 12   | 24h    |
| 5th command data structure | 12   | 30h    |
| Error data structure       | 30   | 3Ch    |
|                            | 90   |        |

---

Figure 129. Error log data structure

**Command data structure:** Data format of each command data structure is shown below.

---

| Description                             | Byte | Offset |
|---|------|--------|
| Device Control register                 | 1    | 00h    |
| Features register                       | 1    | 01h    |
| Sector count register                   | 1    | 02h    |
| Sector number register                  | 1    | 03h    |
| Cylinder Low register                   | 1    | 04h    |
| Cylinder High register                  | 1    | 05h    |
| Device/Head register                    | 1    | 06h    |
| Command register                        | 1    | 07h    |
| Time stamp (milliseconds from Power On) | 4    | 08h    |
|   | 12   |        |

---

Figure 130. Command data structure

### 13.32.4.5 Error data structure

Data format of error data structure is shown below.

---

| Description                           | Byte | Offset |
|---------------------------------------|------|--------|
| Reserved                              | 1    | 00h    |
| Error register                        | 1    | 01h    |
| Sector count register                 | 1    | 02h    |
| Sector number register                | 1    | 03h    |
| Cylinder Low register                 | 1    | 04h    |
| Cylinder High register                | 1    | 05h    |
| Device/Head register                  | 1    | 06h    |
| Status register                       | 1    | 07h    |
| Extended error data (vendor specific) | 19   | 08h    |
| State                                 | 1    | 1Bh    |
| Life time stamp (hours)               | 2    | 1Ch    |
|                                       | 30   |        |

---

Figure 131. Error data structure

State field contains a value indicating the device state when command was issued to the device.

| Value   | State                            |
|---------|----------------------------------|
| x0h     | Unknown                          |
| x1h     | Sleep                            |
| x2h     | Standby                          |
| x3h     | Active/Idle                      |
| x4h     | S.M.A.R.T. Off-line or Self-test |
| x5h–xAh | Reserved                         |
| xBh–xFh | Vendor specific                  |

*Note: The value of the x is vendor specific.*

### 13.32.5 Self-test log data structure

The following defines the 512 bytes that make up the Self-test log sector. All multibyte fields shown in these data structures follow the ATA/ATAPI-5 specifications for byte ordering.

---

| Description                   | Byte | Offset    |
|-------------------------------|------|-----------|
| Data structure revision       | 2    | 00h       |
| Self-test number              | 1    | n*18h+02h |
| Self-test execution status    | 1    | n*18h+03h |
| Life time power on hours      | 2    | n*18h+04h |
| Self-test failure check point | 1    | n*18h+06h |
| LBA of first failure          | 4    | n*18h+07h |
| Vendor specific               | 15   | n*18h+08h |
| ...                           |      |           |
| Vendor specific               | 2    | 1FAh      |
| Self-test log pointer         | 1    | 1FCh      |
| Reserved                      | 2    | 1FDh      |
| Data structure checksum       | 1    | 1FFh      |
|                               | 512  |           |

*Note:* N is 0 through 20

---

Figure 132. Self-test log data structure

The data structure contains the descriptor of the Self-test that the device has performed. Each descriptor is 24 bytes long and the self-test data structure is capable to contain up to 21 descriptors.

After 21 descriptors has been recorded, the oldest descriptor will be overwritten with the new descriptor.

The self-test log pointer points to the most recent descriptor. When there is no descriptor, the value is 0. When there are descriptor(s), the value is 1 through 21.

## 13.32.6 Error reporting

The following table shows the values returned in the Status and Error Registers when specific error conditions are encountered by a device.

| Error condition  | Status Register | Error Register |
|--|-----------------|----------------|
| A S.M.A.R.T. FUNCTION SET command was received by the device without the required key being loaded into the Cylinder High and Cylinder Low registers.                  | 51h             | 04h            |
| A S.M.A.R.T. FUNCTION SET command was received by the device with a subcommand value in the Features Register that is either invalid or not supported by this device.  | 51h             | 04h            |
| A S.M.A.R.T. FUNCTION SET command subcommand other than S.M.A.R.T. ENABLE OPERATIONS was received by the device while the device was in a "S.M.A.R.T. Disabled" state. | 51h             | 04h            |
| The device is unable to read its Attribute Values or Attribute Thresholds data structure   | 51h             | 10h or 40h     |
| The device is unable to write to its Attribute Values data structure.  | 51h             | 10h or 01h     |

Figure 133. S.M.A.R.T. Error Codes

## 13.33 Standby (E2h/96h)

| Command Block Output Registers |   |   |   |   |   |   |   | Command Block Input Registers |               |           |   |   |   |   |   |   |   |
|--------------------------------|---|---|---|---|---|---|---|-------------------------------|---------------|-----------|---|---|---|---|---|---|---|
| Register                       | 7 | 6 | 5 | 4 | 3 | 2 | 1 | 0                             | Register      | 7         | 6 | 5 | 4 | 3 | 2 | 1 | 0 |
| Data                           | - | - | - | - | - | - | - | -                             | Data          | -         | - | - | - | - | - | - | - |
| Feature                        | - | - | - | - | - | - | - | -                             | Error         | see below |   |   |   |   |   |   |   |
| Sector Count                   | V | V | V | V | V | V | V | V                             | Sector Count  | -         | - | - | - | - | - | - | - |
| Sector Number                  | - | - | - | - | - | - | - | -                             | Sector Number | -         | - | - | - | - | - | - | - |
| Cylinder Low                   | - | - | - | - | - | - | - | -                             | Cylinder Low  | -         | - | - | - | - | - | - | - |
| Cylinder High                  | - | - | - | - | - | - | - | -                             | Cylinder High | -         | - | - | - | - | - | - | - |
| Device/Head                    | 1 | - | 1 | D | - | - | - | -                             | Device/Head   | -         | - | - | - | - | - | - | - |
| Command                        | 1 | 1 | 1 | 0 | 0 | 0 | 1 | 0                             | Status        | see below |   |   |   |   |   |   |   |

| Error Register |     |   |     |   |     |     |     |
|----------------|-----|---|-----|---|-----|-----|-----|
| 7              | 6   | 5 | 4   | 3 | 2   | 1   | 0   |
| CRC            | UNC | 0 | IDN | 0 | ABT | TON | AMN |
| 0              | 0   | 0 | 0   | 0 | V   | 0   | 0   |

| Status Register |     |    |     |     |     |     |     |
|-----------------|-----|----|-----|-----|-----|-----|-----|
| 7               | 6   | 5  | 4   | 3   | 2   | 1   | 0   |
| BSY             | RDY | DF | DSC | DRQ | COR | IDX | ERR |
| 0               | V   | 0  | V   | -   | 0   | -   | V   |

Figure 134. Standby command (E2h/96h)

The Standby command causes the device to enter the Standby Mode immediately and to set the auto power down time-out parameter (standby timer).

When this command is issued, the device confirms the completion of the cached write commands before it asserts the INTRQ. Following the INTRQ the interface remains active and the device is spun down. If the device is already spun down, the spin down sequence is not executed.

During the Standby mode the device will respond to commands, however there will be a delay while waiting for the spindle to reach operating speed.

The timer starts counting down when the device returns to Idle mode.

### Output parameters to the device

**Sector Count** The Time-out Parameter. If it is zero, the time-out interval (Standby Timer) is NOT disabled but is automatically set to 109 minutes. If it is other than zero the time-out interval is set for (Time-out Parameter × 5) seconds.

When the automatic power down sequence is enabled, the device will enter the Standby mode automatically if the time-out interval expires with no device access from the host. The time-out interval will be reinitialized if there is a device access before the time-out interval expires.

## 13.34 Standby Immediate (E0h/94h)

| Command Block Output Registers |   |   |   |   |   |   |   | Command Block Input Registers |               |           |   |   |   |   |   |   |   |
|--------------------------------|---|---|---|---|---|---|---|-------------------------------|---------------|-----------|---|---|---|---|---|---|---|
| Register                       | 7 | 6 | 5 | 4 | 3 | 2 | 1 | 0                             | Register      | 7         | 6 | 5 | 4 | 3 | 2 | 1 | 0 |
| Data                           | - | - | - | - | - | - | - | -                             | Data          | -         | - | - | - | - | - | - | - |
| Feature                        | - | - | - | - | - | - | - | -                             | Error         | see below |   |   |   |   |   |   |   |
| Sector Count                   | - | - | - | - | - | - | - | -                             | Sector Count  | -         | - | - | - | - | - | - | - |
| Sector Number                  | - | - | - | - | - | - | - | -                             | Sector Number | -         | - | - | - | - | - | - | - |
| Cylinder Low                   | - | - | - | - | - | - | - | -                             | Cylinder Low  | -         | - | - | - | - | - | - | - |
| Cylinder High                  | - | - | - | - | - | - | - | -                             | Cylinder High | -         | - | - | - | - | - | - | - |
| Device/Head                    | 1 | - | 1 | D | - | - | - | -                             | Device/Head   | -         | - | - | - | - | - | - | - |
| Command                        | 1 | 1 | 1 | 0 | 0 | 0 | 0 | 0                             | Status        | see below |   |   |   |   |   |   |   |

| Error Register |     |   |     |   |     |     |     |
|----------------|-----|---|-----|---|-----|-----|-----|
| 7              | 6   | 5 | 4   | 3 | 2   | 1   | 0   |
| CRC            | UNC | 0 | IDN | 0 | ABT | T0N | AMN |
| 0              | 0   | 0 | 0   | 0 | V   | 0   | 0   |

| Status Register |     |    |     |     |     |     |     |
|-----------------|-----|----|-----|-----|-----|-----|-----|
| 7               | 6   | 5  | 4   | 3   | 2   | 1   | 0   |
| BSY             | RDY | DF | DSC | DRQ | COR | IDX | ERR |
| 0               | V   | 0  | V   | -   | 0   | -   | V   |

Figure 135. Standby Immediate command (E0h/94h)

The Standby Immediate command causes the device to enter the Standby mode immediately.

When this command is issued, the device confirms the completion of the cached write commands before it asserts the INTRQ. Following the INTRQ the interface remains active and the device is spun down. If the device is already spun down, the spin down sequence is not executed.

During the Standby mode the device will respond to commands, however there will be a delay while waiting for the spindle to reach operating speed.

The Standby Immediate command will not affect the auto power down time-out parameter.

## 13.35 Write Buffer (E8h)

| Command Block Output Registers |   |   |   |   |   |   |   | Command Block Input Registers |               |           |   |   |   |   |   |   |   |
|--------------------------------|---|---|---|---|---|---|---|-------------------------------|---------------|-----------|---|---|---|---|---|---|---|
| Register                       | 7 | 6 | 5 | 4 | 3 | 2 | 1 | 0                             | Register      | 7         | 6 | 5 | 4 | 3 | 2 | 1 | 0 |
| Data                           | - | - | - | - | - | - | - | -                             | Data          | -         | - | - | - | - | - | - | - |
| Feature                        | - | - | - | - | - | - | - | -                             | Error         | see below |   |   |   |   |   |   |   |
| Sector Count                   | - | - | - | - | - | - | - | -                             | Sector Count  | -         | - | - | - | - | - | - | - |
| Sector Number                  | - | - | - | - | - | - | - | -                             | Sector Number | -         | - | - | - | - | - | - | - |
| Cylinder Low                   | - | - | - | - | - | - | - | -                             | Cylinder Low  | -         | - | - | - | - | - | - | - |
| Cylinder High                  | - | - | - | - | - | - | - | -                             | Cylinder High | -         | - | - | - | - | - | - | - |
| Device/Head                    | 1 | - | 1 | D | - | - | - | -                             | Device/Head   | -         | - | - | - | - | - | - | - |
| Command                        | 1 | 1 | 1 | 0 | 1 | 0 | 0 | 0                             | Status        | see below |   |   |   |   |   |   |   |

| Error Register |     |   |     |   |     |     |     |
|----------------|-----|---|-----|---|-----|-----|-----|
| 7              | 6   | 5 | 4   | 3 | 2   | 1   | 0   |
| CRC            | UNC | 0 | IDN | 0 | ABT | T0N | AMN |
| 0              | 0   | 0 | 0   | 0 | V   | 0   | 0   |

| Status Register |     |    |     |     |     |     |     |
|-----------------|-----|----|-----|-----|-----|-----|-----|
| 7               | 6   | 5  | 4   | 3   | 2   | 1   | 0   |
| BSY             | RDY | DF | DSC | DRQ | COR | IDX | ERR |
| 0               | V   | 0  | -   | -   | 0   | -   | V   |

Figure 136. Write Buffer command (E8h)

The Write Buffer command transfers a sector of data from the host to the sector buffer of the device. The sectors of data are transferred through the Data Register 16 bits at a time.

The Read Buffer and Write Buffer commands are synchronized such that sequential Write Buffer and Read Buffer commands access the same 512 byte within the buffer.

## 13.36 Write DMA (CAh/CBh)

| Command Block Output Registers |   |   |   |   |   |   |   | Command Block Input Registers |               |           |   |   |   |   |   |   |   |
|--------------------------------|---|---|---|---|---|---|---|-------------------------------|---------------|-----------|---|---|---|---|---|---|---|
| Register                       | 7 | 6 | 5 | 4 | 3 | 2 | 1 | 0                             | Register      | 7         | 6 | 5 | 4 | 3 | 2 | 1 | 0 |
| Data                           | - | - | - | - | - | - | - | -                             | Data          | -         | - | - | - | - | - | - | - |
| Feature                        | - | - | - | - | - | - | - | -                             | Error         | see below |   |   |   |   |   |   |   |
| Sector Count                   | V | V | V | V | V | V | V | V                             | Sector Count  | V         | V | V | V | V | V | V | V |
| Sector Number                  | V | V | V | V | V | V | V | V                             | Sector Number | V         | V | V | V | V | V | V | V |
| Cylinder Low                   | V | V | V | V | V | V | V | V                             | Cylinder Low  | V         | V | V | V | V | V | V | V |
| Cylinder High                  | V | V | V | V | V | V | V | V                             | Cylinder High | V         | V | V | V | V | V | V | V |
| Device/Head                    | 1 | L | 1 | D | H | H | H | H                             | Device/Head   | -         | - | - | - | H | H | H | H |
| Command                        | 1 | 1 | 0 | 0 | 1 | 0 | 1 | R                             | Status        | see below |   |   |   |   |   |   |   |

| Error Register |     |   |     |   |     |     |     |
|----------------|-----|---|-----|---|-----|-----|-----|
| 7              | 6   | 5 | 4   | 3 | 2   | 1   | 0   |
| CRC            | UNC | 0 | IDN | 0 | ABT | T0N | AMN |
| V              | 0   | 0 | V   | 0 | V   | 0   | 0   |

| Status Register |     |    |     |     |     |     |     |
|-----------------|-----|----|-----|-----|-----|-----|-----|
| 7               | 6   | 5  | 4   | 3   | 2   | 1   | 0   |
| BSY             | RDY | DF | DSC | DRQ | COR | IDX | ERR |
| 0               | V   | V  | V   | -   | 0   | -   | V   |

Figure 137. Write DMA command (CAh/CBh)

The Write DMA command transfers one or more sectors of data from the host to the device and then the data is written to the disk media.

The sectors of data are transferred through the Data Register 16 bits at a time.

The host initializes a slave-DMA channel prior to issuing the command. Data transfers are qualified by DMARQ and are performed by the slave-DMA channel. The device issues only one interrupt per command to indicate that data transfer has terminated and status is available.

If an uncorrectable error occurs, the write will be terminated at the failing sector.

### Output parameters to the device

**Sector Count** This indicates the number of continuous sectors to be transferred. If zero is specified, then 256 sectors will be transferred.

**Sector Number** This indicates the sector number of the first sector to be transferred. (L = 0)  
In LBA mode this register contains the LBA bits 0–7. (L = 1)

**Cylinder High/Low** This indicates number of the first sector to be transferred. (L = 0)  
In LBA mode this register contains the LBA bits 8–15 (Low) and bits 16–23 (High). (L = 1)

**H** This indicates the head number of the first sector to be transferred. (L = 0)  
In LBA mode this register contains the LBA bits 24–27. (L = 1)

**R** This indicates the retry bit, but this bit is ignored.

**Input parameters from the device**

**Sector Count** This indicates the number of requested sectors not transferred. The Sector Count will be zero unless an unrecoverable error occurs.

**Sector Number** This indicates the sector number of the last transferred sector. (L = 0)  
In LBA mode this register contains the current LBA bits 0–7. (L = 1)

**Cylinder High/Low** This indicates the cylinder number of the last transferred sector. (L = 0)  
In LBA mode this register contains the current LBA bits 8–15 (Low) and bits 16–23 (High). (L = 1)

**H** This indicates the head number of the last transferred sector. (L = 0)  
In LBA mode this register contains the current LBA bits 24–27. (L = 1)

## 13.37 Write Long (32h/33h)

| Command Block Output Registers |   |   |   |   |   |   |   | Command Block Input Registers |               |           |   |   |   |   |   |   |   |   |
|--------------------------------|---|---|---|---|---|---|---|-------------------------------|---------------|-----------|---|---|---|---|---|---|---|---|
| Register                       | 7 | 6 | 5 | 4 | 3 | 2 | 1 | 0                             | Register      | 7         | 6 | 5 | 4 | 3 | 2 | 1 | 0 |   |
| Data                           | - | - | - | - | - | - | - | -                             | Data          | -         | - | - | - | - | - | - | - |   |
| Feature                        | - | - | - | - | - | - | - | -                             | Error         | see below |   |   |   |   |   |   |   |   |
| Sector Count                   | 0 | 0 | 0 | 0 | 0 | 0 | 0 | 1                             | Sector Count  | -         | - | - | - | - | - | - | - | V |
| Sector Number                  | V | V | V | V | V | V | V | V                             | Sector Number | V         | V | V | V | V | V | V | V | V |
| Cylinder Low                   | V | V | V | V | V | V | V | V                             | Cylinder Low  | V         | V | V | V | V | V | V | V | V |
| Cylinder High                  | V | V | V | V | V | V | V | V                             | Cylinder High | V         | V | V | V | V | V | V | V | V |
| Device/Head                    | 1 | L | 1 | D | H | H | H | H                             | Device/Head   | -         | - | - | - | H | H | H | H |   |
| Command                        | 0 | 0 | 1 | 1 | 0 | 0 | 1 | R                             | Status        | see below |   |   |   |   |   |   |   |   |

| Error Register |     |   |     |   |     |     |     |
|----------------|-----|---|-----|---|-----|-----|-----|
| 7              | 6   | 5 | 4   | 3 | 2   | 1   | 0   |
| CRC            | UNC | 0 | IDN | 0 | ABT | T0N | AMN |
| 0              | 0   | 0 | V   | 0 | V   | 0   | 0   |

| Status Register |     |    |     |     |     |     |     |
|-----------------|-----|----|-----|-----|-----|-----|-----|
| 7               | 6   | 5  | 4   | 3   | 2   | 1   | 0   |
| BSY             | RDY | DF | DSC | DRQ | COR | IDX | ERR |
| 0               | V   | V  | V   | -   | 0   | -   | V   |

Figure 138. Write Long command (32h/33h)

The Write Long command transfers the data and the ECC bytes of the designated one sector from the host to the device, then the data and the ECC bytes are written to the disk media.

After 512 bytes of data have been transferred, the device will keep setting DRQ = 1 to indicate that the device is ready to receive the ECC bytes from the host. The data is transferred 16 bits at a time and the ECC bytes are transferred 8 bits at a time. The number of ECC bytes are either 4 or 40 according to setting of the Set Feature option. The default number after power on is 4 bytes.

### Output parameters to the device

**Sector Count** This indicates the number of continuous sectors to be transferred. The Sector Count must be set to one.

**Sector Number** This indicates the sector number of the sector to be transferred. (L = 0)  
In LBA mode this register contains the LBA bits 0–7. (L = 1)

**Cylinder High/Low** This indicates the cylinder number of the sector to be transferred. (L = 0)  
In LBA mode this register contains the LBA bits 8–15 (Low) and bits 16–23 (High). (L = 1)

- H** This indicates the head number of the sector to be transferred. (L = 0)  
In LBA mode this register contains the LBA bits 24–27. (L = 1)
- R** The retry bit, but this bit is ignored.

**Input parameters from the device**

- Sector Count** This indicates the number of requested sectors not transferred.
- Sector Number** This indicates the sector number of the sector to be transferred. (L = 0)  
In LBA mode this register contains the current LBA bits 0–7. (L = 1)
- Cylinder High/Low** This indicates the cylinder number of the sector to be transferred. (L = 0)  
In LBA mode this register contains current the LBA bits 8–15 (Low) and bits 16–23 (High). (L = 1)
- H** This indicates the head number of the sector to be transferred. (L = 0)  
In LBA mode this register contains current the LBA bits 24–27. (L = 1)

The drive internally uses 40 bytes of ECC on all data read or writes. The 4-byte mode of operation is provided via an emulation technique. As a consequence of this emulation it is recommended that 40 byte ECC mode is used for all tests to confirm the operation of the ECC hardware of the drive. Unexpected results may occur if such testing is performed using 4-byte mode.

## 13.38 Write Multiple (C5h)

| Command Block Output Registers |   |   |   |   |   |   |   | Command Block Input Registers |               |           |   |   |   |   |   |   |   |
|--------------------------------|---|---|---|---|---|---|---|-------------------------------|---------------|-----------|---|---|---|---|---|---|---|
| Register                       | 7 | 6 | 5 | 4 | 3 | 2 | 1 | 0                             | Register      | 7         | 6 | 5 | 4 | 3 | 2 | 1 | 0 |
| Data                           | - | - | - | - | - | - | - | -                             | Data          | -         | - | - | - | - | - | - | - |
| Feature                        | - | - | - | - | - | - | - | -                             | Error         | see below |   |   |   |   |   |   |   |
| Sector Count                   | V | V | V | V | V | V | V | V                             | Sector Count  | V         | V | V | V | V | V | V | V |
| Sector Number                  | V | V | V | V | V | V | V | V                             | Sector Number | V         | V | V | V | V | V | V | V |
| Cylinder Low                   | V | V | V | V | V | V | V | V                             | Cylinder Low  | V         | V | V | V | V | V | V | V |
| Cylinder High                  | V | V | V | V | V | V | V | V                             | Cylinder High | V         | V | V | V | V | V | V | V |
| Device/Head                    | 1 | L | 1 | D | H | H | H | H                             | Device/Head   | -         | - | - | - | H | H | H | H |
| Command                        | 1 | 1 | 0 | 0 | 0 | 1 | 0 | 1                             | Status        | see below |   |   |   |   |   |   |   |

| Error Register |     |   |     |   |     |     |     |
|----------------|-----|---|-----|---|-----|-----|-----|
| 7              | 6   | 5 | 4   | 3 | 2   | 1   | 0   |
| CRC            | UNC | 0 | IDN | 0 | ABT | T0N | AMN |
| 0              | 0   | 0 | V   | 0 | V   | 0   | 0   |

| Status Register |     |    |     |     |     |     |     |
|-----------------|-----|----|-----|-----|-----|-----|-----|
| 7               | 6   | 5  | 4   | 3   | 2   | 1   | 0   |
| BSY             | RDY | DF | DSC | DRQ | COR | IDX | ERR |
| 0               | V   | V  | V   | -   | 0   | -   | V   |

Figure 139. Write Multiple command (C5h)

The Write Multiple command transfers one or more sectors from the host to the device. The data is then written to the disk media.

Command execution is identical to the Write Sectors command except that an interrupt is generated for each block as defined by the Set Multiple command instead of for each sector. The sectors are transferred through the Data Register 16 bits at a time.

### Output parameters to the device

**Sector Count** This indicates the number of continuous sectors to be transferred. If the Sector Count of zero is specified, 256 sectors will be transferred.

**Sector Number** This indicates the sector number of the first sector to be transferred. (L = 0)  
In LBA mode this register contains the LBA bits 0–7. (L = 1)

**Cylinder High/Low** This indicates the cylinder number of the first sector to be transferred. (L = 0)  
In LBA mode this register contains the LBA bits 8–15 (Low) and bits 16–23 (High). (L = 1)

**H** This indicates the head number of the first sector to be transferred. (L = 0)  
In LBA mode this register contains the LBA bits 24–27. (L = 1)

### Input parameters from the device

|                          |   |
|--------------------------|---|
| <b>Sector Count</b>      | This indicates the number of requested sectors not transferred. The Sector Count will be zero, unless an unrecoverable error occurs.  |
| <b>Sector Number</b>     | This indicates the sector number of the last transferred sector. (L = 0)<br>In LBA mode this register contains current the LBA bits 0–7. (L = 1)                                |
| <b>Cylinder High/Low</b> | This indicates the cylinder number of the last transferred sector. (L = 0)<br>In LBA mode this register contains the current LBA bits 8–15 (Low) and bits 16–23 (High). (L = 1) |
| <b>H</b>                 | This indicates the head number of the last transferred sector. (L = 0)<br>In LBA mode this register contains current the LBA bits 24–27. (L = 1)                                |

## 13.39 Write Sectors (30h/31h)

| Command Block Output Registers |   |   |   |   |   |   |   | Command Block Input Registers |               |           |   |   |   |   |   |   |   |
|--------------------------------|---|---|---|---|---|---|---|-------------------------------|---------------|-----------|---|---|---|---|---|---|---|
| Register                       | 7 | 6 | 5 | 4 | 3 | 2 | 1 | 0                             | Register      | 7         | 6 | 5 | 4 | 3 | 2 | 1 | 0 |
| Data                           | - | - | - | - | - | - | - | -                             | Data          | -         | - | - | - | - | - | - | - |
| Feature                        | - | - | - | - | - | - | - | -                             | Error         | see below |   |   |   |   |   |   |   |
| Sector Count                   | V | V | V | V | V | V | V | V                             | Sector Count  | V         | V | V | V | V | V | V | V |
| Sector Number                  | V | V | V | V | V | V | V | V                             | Sector Number | V         | V | V | V | V | V | V | V |
| Cylinder Low                   | V | V | V | V | V | V | V | V                             | Cylinder Low  | V         | V | V | V | V | V | V | V |
| Cylinder High                  | V | V | V | V | V | V | V | V                             | Cylinder High | V         | V | V | V | V | V | V | V |
| Device/Head                    | 1 | L | 1 | D | H | H | H | H                             | Device/Head   | -         | - | - | - | H | H | H | H |
| Command                        | 0 | 0 | 1 | 1 | 0 | 0 | 0 | R                             | Status        | see below |   |   |   |   |   |   |   |

| Error Register |     |   |     |   |     |     |     |
|----------------|-----|---|-----|---|-----|-----|-----|
| 7              | 6   | 5 | 4   | 3 | 2   | 1   | 0   |
| CRC            | UNC | 0 | IDN | 0 | ABT | T0N | AMN |
| 0              | 0   | 0 | V   | 0 | V   | 0   | 0   |

| Status Register |     |    |     |     |     |     |     |
|-----------------|-----|----|-----|-----|-----|-----|-----|
| 7               | 6   | 5  | 4   | 3   | 2   | 1   | 0   |
| BSY             | RDY | DF | DSC | DRQ | COR | IDX | ERR |
| 0               | V   | V  | V   | -   | 0   | -   | V   |

Figure 140. Write Sectors command (30h/31h)

The Write Sectors command transfers one or more sectors from the host to the device. The data is then written to the disk media.

The sectors are transferred through the Data Register 16 bits at a time.

If an uncorrectable error occurs, the write will be terminated at the failing sector, when the auto reassign function is disable.

### Output parameters to the device

**Sector Count** This indicates the number of continuous sectors to be transferred. If the Sector Count of zero is specified, 256 sectors will be transferred.

**Sector Number** This indicates the sector number of the first sector to be transferred. (L = 0)  
In LBA mode this register contains the LBA bits 0–7. (L = 1)

**Cylinder High/Low** This indicates the cylinder number of the first sector to be transferred. (L = 0)  
In LBA mode this register contains the LBA bits 8–15 (Low) and bits 16–23 (High). (L = 1)

**H** This indicates the head number of the first sector to be transferred. (L = 0)  
In LBA mode this register contains the LBA bits 24–27. (L = 1)

**R** This indicates the retry bit, but this bit is ignored.

### Input parameters from the device

|                          |   |
|--------------------------|---|
| <b>Sector Count</b>      | This indicates the number of requested sectors not transferred. The Sector Count will be zero unless an unrecoverable error occurs.   |
| <b>Sector Number</b>     | This indicates the sector number of the last transferred sector. (L = 0)<br>In LBA mode this register contains the current LBA bits 0–7. (L = 1)                                |
| <b>Cylinder High/Low</b> | This indicates the cylinder number of the last transferred sector. (L = 0)<br>In LBA mode this register contains the current LBA bits 8–15 (Low) and bits 16–23 (High). (L = 1) |
| <b>H</b>                 | This indicates the head number of the last transferred sector. (L = 0)<br>In LBA mode this register contains the current LBA bits 24–27. (L = 1)                                |

---

## **13.40 Write Verify (3Ch: vendor specific)**

In the implementation of the drive the Write Verify command is exactly the same as the Write Sectors command (30h). Read verification is not performed after the write operation.

Refer to 13.39, "Write Sectors Command" on page 191 for parameters.

This page intentionally left blank.

## 14.0 Time-out values

The timing of BSY and DRQ in Status Register are shown in the table below.

|                           | INTERVAL                            | START                                     | STOP   | TIME-OUT                |
|---------------------------|-------------------------------------|---|--|-------------------------|
| Power On                  | Device Busy After Power On          | Power On                                  | Status Register BSY=1                        | 400 ns                  |
|                           | Device Ready After Power On         | Power On                                  | Status Register BSY=1 and RDY=1              | 31 sec                  |
| Software Reset            | Device Busy After Software Reset    | Device Control Register RST=1             | Status Register BSY=1                        | 400 ns                  |
|                           | Device Ready After Software Reset   | Device Control Register RST=0 After RST=1 | Status Register BSY=0 and RDY=1              | 31 sec                  |
| Hard Reset                | Device Busy After Hard Reset        | Bus RESET Signal Asserted                 | Status Register BSY=1                        | 400 ns                  |
|                           | Device Ready After Hard Reset       | Bus RESET Signal Asserted                 | Status Register BSY=0 and RDY=1              | 31 sec                  |
| Data In Command           | Device Busy After Command Code Out  | OUT To Command Register                   | Status Register BSY=1                        | 400 ns                  |
|                           | Interrupt, DRQ For Data Transfer In | Status Register BSY=1                     | Status Register BSY=0 and DRQ=1, Interrupt   | 30 sec                  |
|                           | Device Busy After Data Transfer In  | 256th Read From Data Register             | Status Register BSY=1                        | 10 $\mu$ s              |
| Data Out Command          | Device Busy After Command Code Out  | OUT to Command Register                   | Status Register BSY=1                        | 400 ns                  |
|                           | Data Request For Data Transfer Out  | Status Register BSY=1                     | Status Register BSY=0 and DRQ=1              | 700 $\mu$ s<br>(Note 3) |
|                           | Device Busy After Data Transfer Out | 256th Write From Data Register            | Status Register BSY=1                        | 5 $\mu$ s               |
|                           | Interrupt For Data Transfer Out     | Status Register BSY=1                     | Status Register BSY=0 and RDY=1<br>Interrupt | 30 sec<br>(Note 1)      |
| Non-Data Command          | Device Busy After Command Code Out  | OUT to Command Register                   | Status Register BSY=1                        | 400 ns                  |
|                           | Interrupt For Command Complete      | Status Register BSY=1                     | Interrupt                                    | 30 sec<br>(Note 2)      |
| DMA Data Transfer Command | Device Busy After Command Code Out  | OUT to Command Register                   | Status Register BSY=1                        | 400 ns                  |

Figure 141. Time-out values

Command category is referred to in section 12.0, "Command protocol" on page 101.

We recommend that the host system execute Soft reset and then retry to issue the command if the host system time-out would occur for the device.

*Note 1.* For SECURITY ERASE UNIT command, the execution time is referred to 13.22, "Security Erase Unit (F4h)" on page 150.

*Note 2.* For FORMAT UNIT command, the execution time is referred to 13.7, "Format Unit (F7h: Vendor Specific)" on page 120.

*Note 3.* When the initial power mode at power on is Standby mode, and when the following commands are issued by the host as First Command, the command's time-out value of the field is 10 seconds:

- Security Disable Password
- Security Erase Unit
- Security Set Password
- Security Unlock.

## 15.0 Appendix

### 15.1 Commands Support Coverage

The table below compares the command support coverage of the Hitachi Travelstar 60GH & 40GN with the ATA-5 defined command set. The third column indicates the capability of the Hitachi Travelstar 60GH & 40GN for those commands.

| Command Code | Command Name                    | Implementation for Hitachi Travelstar 60GH & 40GN | ATA-5 Category Type |
|--------------|---------------------------------|---|---------------------|
| 00h          | NOP                             | No  | Optional            |
| 03h          | CFA REQUEST EXTENDED ERROR CODE | No  | Optional (Note 7)   |
| 08h          | DEVICE RESET                    | No  | Optional (Note 7)   |
| 1xh          | RECALIBRATE                     | Yes   | Obsoleted           |
| 20h          | READ SECTOR(S)                  | Yes   | Mandatory           |
| 21h          | READ SECTOR(S)                  | Yes   | Obsoleted           |
| 22h          | READ LONG                       | Yes   | Obsoleted           |
| 23h          | READ LONG                       | Yes   | Obsoleted           |
| 30h          | WRITE SECTOR(S)                 | Yes   | Mandatory           |
| 31h          | WRITE SECTOR(S)                 | Yes   | Obsoleted           |
| 32h          | WRITE LONG                      | Yes   | Obsoleted           |
| 33h          | WRITE LONG                      | Yes   | Obsoleted           |
| 38h          | CFA TRANSLATE SECTORS W/O ERASE | No  | Optional (Note 7)   |
| 3Ch          | WRITE VERIFY (2)                | Vendor specific                                   | Obsoleted           |
| 40h          | READ VERIFY SECTOR(S)           | Yes   | Mandatory           |
| 41h          | READ VERIFY SECTOR(S)           | Yes   | Obsoleted           |
| 50h          | FORMAT TRACK                    | Yes   | Obsoleted           |
| 7xh          | SEEK                            | Yes   | Mandatory           |
| 87h          | CFA TRANSLATE SECTORS           | No  | Optional            |
| 90h          | EXECUTE DEVICE DIAGNOSTIC       | Yes   | Mandatory           |
| 91h          | INITIALIZE DEVICE PARAMETERS    | Yes   | Mandatory           |
| 92h          | DOWNLOAD MICROCODE              | Reserved  | Optional            |
| 94h-99h      | Reserved                        | Reserved  | Reserved            |
| A0h          | PACKET                          | No  | Not to be used      |
| A1h          | IDENTIFY PACKET DEVICE          | No  | Not to be used      |
| A2H          | SERVICE                         | No  | Not to be used      |
| B0h          | S.M.A.R.T. FUNCTION SET         | Yes   | Optional (Note 5)   |
| C0h          | CFA ERASE SECTORS               | No  | Optional            |
| C4h          | READ MULTIPLE                   | Yes   | Mandatory           |
| C5h          | WRITE MULTIPLE                  | Yes   | Mandatory           |
| C6h          | SET MULTIPLE MODE               | Yes   | Mandatory           |
| C7h          | READ DMA QUEUED                 | No  | Optional            |
| C8h          | READ DMA                        | Yes   | Mandatory           |
| C9h          | READ DMA                        | Yes   | Obsoleted           |

Figure 142. Command coverage (1 of 2)

| Command Code | Command Name                  | Implementation for Hitachi Travelstar 60GH & 40GN | ATA-5 Command Type |
|--------------|-------------------------------|---|--------------------|
| CAh          | WRITE DMA                     | Yes   | Mandatory          |
| CBh          | WRITE DMA                     | Yes   | Obsoleted          |
| CCh          | WRITE DMA QUEUED              | No  | Optional           |
| CDh          | CFA WRITE MULTIPLE W/O ERASE  | No  | Optional (Note 7)  |
| DAh          | GET MEDIA STATUS              | No  | Optional (Note 7)  |
| DEh          | MEDIA LOCK                    | No  | Optional (Note 7)  |
| DFh          | MEDIA UNLOCK                  | No  | Optional (Note 7)  |
| E0h          | STANDBY IMMEDIATE             | Yes   | Mandatory          |
| E1h          | IDLE IMMEDIATE                | Yes   | Mandatory          |
| E2h          | STANDBY                       | Yes   | Mandatory          |
| E3h          | IDLE                          | Yes   | Mandatory          |
| E4h          | READ BUFFER                   | Yes   | Optional           |
| E5h          | CHECK POWER MODE              | Yes   | Mandatory          |
| E6h          | SLEEP                         | Yes   | Mandatory          |
| E7h          | FLUSH CACHE                   | Yes   | Mandatory          |
| E8h          | WRITE BUFFER                  | Yes   | Optional           |
| ECh          | IDENTIFY DEVICE               | Yes   | Mandatory          |
| EDh          | MEDIA EJECT                   | No  | Optional (Note 7)  |
| EEh          | IDENTIFY DEVICE DMA           | No  | Obsoleted          |
| EFh          | SET FEATURES                  | Yes   | Mandatory          |
| F0h          | SENSE CONDITION               | Vendor specific                                   | Vendor specific    |
| F1h          | SECURITY SET PASSWORD         | Yes   | Optional (Note 6)  |
| F2h          | SECURITY UNLOCK               | Yes   | Optional (Note 6)  |
| F3h          | SECURITY ERASE PREPARE        | Yes   | Optional (Note 6)  |
| F4h          | SECURITY ERASE UNIT           | Yes   | Optional (Note 6)  |
| F5h          | SECURITY FREEZE LOCK          | Yes   | Optional (Note 6)  |
| F6h          | SECURITY DISABLE PASSWORD     | Yes   | Optional (Note 6)  |
| F7h          | FORMAT UNIT                   | Vendor specific                                   | Vendor specific    |
| F8h          | READ NATIVE MAX ADDRESS       | Yes   | Optional           |
| F9h          | SET MAX ADDRESS               | Yes   | Optional           |
| FAh          | ENABLE/DISABLE DELAYED WRITE  | Yes   | Vendor specific    |
| FB-FFh       | Vendor specific               | Reserved  | Vendor specific    |
|              | Reserved: all remaining codes | Reserved  | Reserved           |

Figure 143. Command coverage (2 of 2)

*Note 1.* These commands have two command codes and appear in this table twice, once for each command code.

*Note 2.* The WRITE VERIFY command implemented vendor specific. The operation is the same as WRITE SECTORS and verification is not performed.

*Note 3.* Protected Area Feature Set

*Note 4.* Power Management Feature Set

*Note 5.* S.M.A.R.T. Function Set

*Note 6.* Security Mode Feature Set

*Note 7.* Removable

## 15.2 SET FEATURES Command Support Coverage

The following table provides a list of Feature Registers, Feature Names, and implementation for the Hitachi Travelstar 60GH & 40GN. The third column indicates whether or not the Hitachi Travelstar 60GH & 40GN has the capability of executing the command in comparison to the ATA-4 defined command set. For detailed operation, refer to section 13.28, "Set Features (EFh)" on page 159.

| Features Register | Features Name                          | Implementation for Hitachi Travelstar 60GH & 40GN |
|-------------------|--|---|
| 02h               | Enable write cache                     | Yes   |
| 03h               | Set transfer mode                      | Yes   |
| 05h               | Enable Advanced Power Management       | Yes   |
| 09h               | Enable Address Offset mode             | Yes   |
| 44h               | Set vendor specific bytes ECC          | Yes   |
| 55h               | Disable read look-ahead feature        | Yes   |
| 5Dh               | Enable release interrupt               | No  |
| 5Eh               | Enable SERVICE interrupt               | No  |
| 66h               | Disable reverting to power on defaults | Yes   |
| 82h               | Disable write cache                    | Yes   |
| 85h               | Disable Advanced Power Management      | Yes   |
| 89h               | Disable Address Offset mode            | Yes   |
| 95h               | Enable Media Status Notification       | No  |
| AAh               | Enable read look-ahead feature         | Yes   |
| BBh               | Set 4 bytes ECC                        | Yes   |
| CCh               | Enable reverting to power on defaults  | Yes   |
| DDh               | Disable release interrupt              | No  |
| EEh               | Disable SERVICE interrupt              | No  |
| others            | Reserved                               | Reserved  |

Figure 144. SET FEATURES command coverage

---

## **15.3 Changes from Hitachi Travelstar 48GH, 30GN & 15GN**

The Hitachi Travelstar 60GH & 40GN has changed one feature present in the Hitachi Travelstar 48GH, 30GN & 15GN:

- The identify device information data.

---

# Index

## A

- ABLE-3, 82
- ABRT, 71
- Active Idle mode, 82
- Adaptive Power Management Feature
  - Low Power Idle Mode, 82
- Address Offset Feature, 95
- Address setting, 58
- Advanced Power Management, 82
- Advanced Power Management Feature
  - Active Idle Mode, 82
  - Performance Idle Mode, 82
  - Transition Time, 82
- Auto Reassign Function, 99
  - Nonrecovered read errors, 99
  - Recovered read errors, 99
- Automatic power down sequence, 182
- Average latency, 16
- Average seek time, 15

## C

- Check Power Mode, 111
- Command
  - Check Power Mode (E5h/98h), 111
  - Enable/Disable Delayed Write (FAh), 116
  - Execute Device Diagnostic (90h), 117
  - Flush Cache (E7h), 118
  - Format Track (50h), 119
  - Identify Device (ECh), 122
  - Idle (E3h/97h), 131
  - Idle Immediate (E1h/95h), 132
  - Initialize Device Parameters (91h), 133
  - Read Buffer (E4h), 134
  - Read DMA (C8h/C9h), 135
  - Read Long (22h/23h), 137
  - Read Multiple (C4h), 139
  - Read Native Max ADDRESS (F8h), 141
  - Read Sectors (20h/21h), 143
  - Read Verify Sectors (40h/41h), 145
  - Recalibrate (1xh), 147
  - S.M.A.R.T. Function Set (B0h), 165
  - Security Disable Password (F6h), 148
  - Security Erase Prepare (F3h), 149
  - Security Erase Unit (F4h), 150
  - Security Freeze Lock (F5h), 152
  - Security Set Password (F1h), 153
  - Security Unlock (F2h), 155
  - Seek (7xh), 157

- Set Features (EFh), 159
- Set Max ADDRESS (F9h), 161
- Set Multiple (C6h), 163
- Sleep (E6h/99h), 164
- Standby (E2h/96h), 182
- Standby Immediate (E0h/94h), 183
- Write Buffer (E8h), 184
- Write DMA (CAh/CBh), 185
- Write Long (32h/33h), 187
- Write Multiple (C5h), 189
- Write Sectors (30h/31h), 191
- Write Verify (3Ch), 193
- Command descriptions, 107
- Command protocol, 101
- Command table, 90
- Commands Support Coverage, 197
- Conductive noise, 24

## D

- DC power requirements, 25
- Default Register Values, 75
- Delayed Write, 98
- Device Attribute Data Structure, 170
- Diagnostic Codes, 75
- Drive ready time, 16

## E

- Electromagnetic compatibility, 39
- Enable/Disable Delayed Write command, 98
- Environmental condition, 23
- Error Register
  - Diagnostic Codes, 75
- Example for operation (In LBA Mode), 92
- Execute Device Diagnostic, 117

## F

- Flush Cache, 118
- Format Track, 119
- Format Unit (F7h: vendor specific), 120
- Full stroke seek, 15

## I

- Identify Device, 101, 122
- Idle, 105, 131
- Idle Immediate, 132
- Individual Attribute Data Structure, 171
- Initial Power Mode at Power On, 81
- Initialize Device Parameters, 133
- Interface Capability for Power Modes, 81
- Interface logic signal levels, 47

## M

Magnetic flux density limits, 24  
Master Password, 86  
Master Password Revision Code, 87

## N

Nonrecovered read errors, 99  
Nonrecovered write errors, 20, 99

## O

Operating modes, 17

## P

Performance Idle mode, 82  
PIO timings, 48  
Power management, 80  
Power Management Feature  
    Initial Power Mode at Power On, 81  
    Power Management Commands, 80  
    Power mode, 80  
    Standby timer, 81  
    Standby/sleep command completion timing, 80  
    Status, 81  
Power-off considerations, 77  
    Emergency unload, 77  
    Load/Unload, 77  
    Required power-off sequence, 78

Protected Area, 92

## R

Radiation noise, 24  
Read Buffer, 101  
Read Buffer (E4h), 134  
Read DMA, 106, 135  
Read Long, 101, 137  
Read Multiple, 101, 139  
Read Native Max ADDRESS, 105, 141  
Read Sectors, 101, 143  
Read Verify Sectors, 105, 145  
Reassign Function, 99  
Recalibrate, 105, 147  
Recovered read errors, 20, 99  
Register  
    Alternate status register, 68  
    Command register, 68  
    Cylinder high register, 68  
    Cylinder low register, 68  
    Data register, 69  
    Device control register, 69  
    Device/head register, 70  
    Drive address register, 70  
    Error register, 71  
    Features register, 71  
    Sector Count Register, 71

Sector Number Register, 72

Status Register, 72

Register Set, 67

Reset

    Diagnostic and reset considerations, 76

    Register initialization, 75

Reset error register values, 76

Reset timings, 47

## S

S.M.A.R.T.

    S.M.A.R.T. operation with power management modes, 85

S.M.A.R.T. Capability, 174

S.M.A.R.T. function, 84

    Attribute thresholds, 84

    Attribute values, 84

    Attributes, 84

    S.M.A.R.T. commands, 84

    Threshold exceeded condition, 84

S.M.A.R.T. Function Set, 165

S.M.A.R.T. Function Subcommands, 166

Safety, 40

Sector Addressing Mode, 78

    LBA addressing mode, 79

    Logical CHS addressing mode, 78

Security, 86

Security Disable Password, 103, 148

Security Erase Prepare, 105, 149

Security Erase Unit, 103, 150

Security Freeze Lock, 105, 152

Security Mode Feature Set, 86

Security Set Password, 103, 153

SECURITY UNLOCK, 89, 103, 155

Seek, 105, 157

Seek Overlap, 97

Service life and usage condition, 28

Set Features, 105, 159

SET FEATURES Command Support Coverage, 199

Set Max ADDRESS, 105, 161

Set Multiple, 163

Set Multiple Mode, 105

Shock, 34

Single track seek time, 16

Sleep, 17, 105, 164

SMART Disable Operations, 105

SMART Enable Operations, 105

SMART Enable/Disable Attribute Autosave, 105

SMART Execute Off-line Immediate, 105

SMART Read Attribute Thresholds, 101

SMART Read Attribute Values, 101

SMART Return Status, 105

SMART Save Attribute Values, 105

Sound power level, 37  
Standby, 105, 182  
Standby Immediate, 105, 183  
Standby timer, 81  
Standby/Sleep command completion timing, 80

## *T*

Table of signals, 42  
Time-out interval, 131  
Time-out Parameter, 131, 132  
Time-out values, 195

## *U*

User Password, 86

## *V*

Vibration, 34

## *W*

Write Buffer, 103, 184  
Write Cache, 19, 98  
Write DMA, 106, 185  
Write Long, 103, 187  
Write Multiple, 103, 189  
Write Sectors, 103, 191  
Write Verify, 103, 193

---

© Copyright Hitachi Global Storage Technologies

Hitachi Global Storage Technologies  
5600 Cottle Road  
San Jose, CA 95193

Produced in the United States

1/03

All rights reserved Travelstar™ is a trademark of Hitachi Global Storage Technologies.

Microsoft, Windows XP, and Windows are trademarks of Microsoft Corporation in the United States, other countries, or both.

Other product names are trademarks or registered trademarks of their respective companies.

References in this publication to Hitachi Global Storage Technologies products, programs or services do not imply that Hitachi Global Storage Technologies intends to make these available in all countries in which Hitachi Global Storage Technologies operates.

Product information is provided for information purposes only and does not constitute a warranty.

Information is true as of the date of publication and is subject to change. Actual results may vary.

This publication is for general guidance only. Photographs may show design models.

13 January 2003

---