



Product summary

Ultrastar 9LZX & 18ZX

Multi-mode SE/LVD



Models: DRVS-09V
DRVS-09D
DRVS-18V
DRVS-18D

IBM has introduced a new range of Low Voltage Differential (Ultra2 SCSI) drives intended for advanced storage applications which demand fast access to large amounts of data.

The Ultrastar 9LZX and 18ZX offer a rotational speed of 10,020 RPM, embedded sector servo, S.M.A.R.T., PRML, and a minimum sustained data transfer rate of 15.2MB/sec.

Applications

- Technical/commercial workstations
- Network servers
- Mass storage arrays
- High-end personal computers
- Large scale imaging and graphics
- Video servers
- Video editing

Features

- 9.1GB & 18.2GB formatted capacity (512 bytes/sector)
- Industry standard interface
 - 68 pin ANSI SCSI-3
 - 80 pin ANSI SCSI-3
- 15.2 - 20.3 MB/sec sustained data transfer rate
- 23.4 - 30.46 MB/sec media transfer rate (peak)
- Rotational speed 10,020 RPM
- Average seek time 5.3 ms (9.1GB) 6.5ms (18.2GB)
- Latency 2.99 ms
- 4 MByte multi-segmented cache buffer
- Low command overhead
- Read ahead caching
- ECC on the fly (EOTF)
- No-ID sector formatting
- PRML data channel
- Predictive Failure Analysis (S.M.A.R.T. compliant)

Benefits

- Range of capacities to meet the need for increasing storage requirements
- Fast interface data rates
 - 40MB/sec (Fast 20) & 80MB/sec (Fast 40) data transfer speed
- High data rate across entire disk surface
- Fast access to data
- Fast data retrieval in single and multi-tasking applications
- Improved data throughput
- More data stored per track, increased sustained data transfer rate
- High reliability and availability

Connectors

The electrical connectors are located as shown.

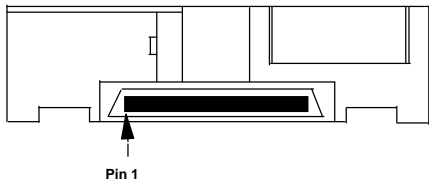

Electrical connectors (rear view) 80 pin SCA models.

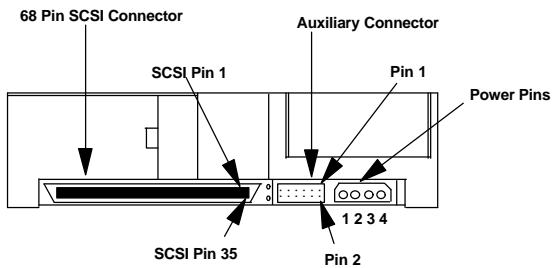

Electrical connectors (rear view) 68 pin models.

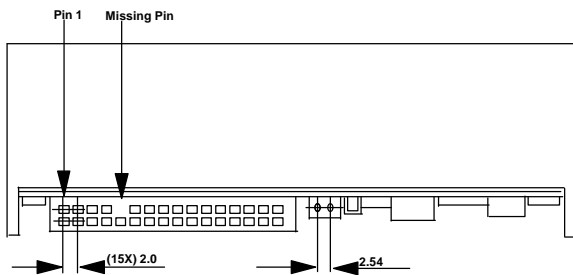

Jumper pin locations (front view) all models.
*Not available on 80 pin SCA.

Note: See electrical interface specifications for power pin assignment.

The DC power connector is designed to mate with AMP part 5-917593-9 (80 pin) and the Molex connector part 87360-0001 (68 pin). Equivalent connectors may be used. Pin assignments are shown below, as viewed from the rear of the drive.

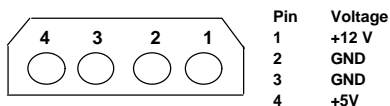

Option Block

Jumper Settings

Jumper position and function are shown below. Pin pitch is 2mm. Termination power enable has a pin pitch of 2.54mm.

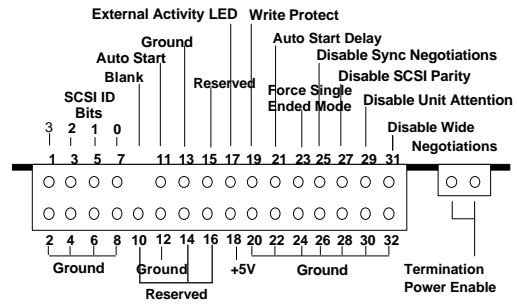

68 pin front jumper block and TermPower block.

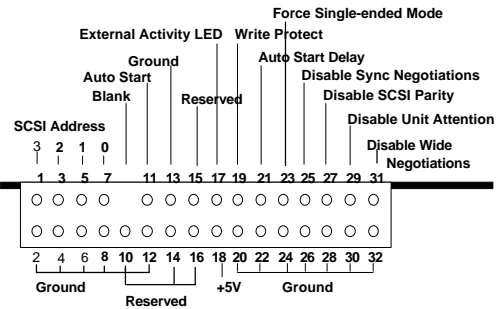

80 pin SCA-2 front option jumper block.

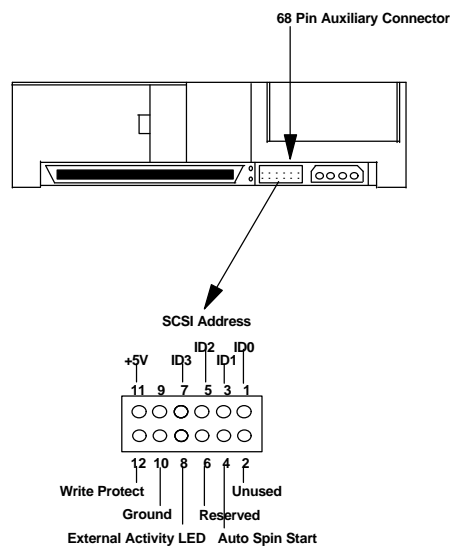

SCSI ID (address) pins

Note: In the address determination tables, “off” means a jumper is not in place and “on” means a jumper is in place.

Bit 3	Bit 2	Bit 1	Bit 0	Address
off	off	off	off	0
off	off	off	on	1
off	off	on	off	2
off	off	on	on	3
off	on	off	off	4
off	on	off	on	5
off	on	on	off	6
off	on	on	on	7
on	off	off	off	8
on	off	off	on	9
on	off	on	off	10
on	off	on	on	11
on	on	off	off	12
on	on	off	on	13
on	on	on	off	14
on	on	on	on	15

Address determination for 68 and 80 pin models.

Auto Start and Delay pins

The Auto Start and Auto Start Delay pins control when and how the drive can spin up and come ready. When configured for Auto Start, the motor spins up after power is applied without the need for a SCSI Start Unit command. (The drive will delay its start time by a period of time multiplied by its own SCSI address.) When the drive is not configured for Auto-Startup, a SCSI Start Unit command is required to make the drive spin and be ready for media access operations.

68 pin interface model			Drive behavior
Auto start delay	Auto start	Auto startup mode	Delay (sec) multiplier
off	off	no	n/a
off	on	yes	0
on	off	yes	10
on	on	yes	4

80 pin interface model			Drive behavior
Auto start delay	Auto start	Auto startup mode	Delay (sec) multiplier
off	off	yes	0
off	on	no	n/a
on	off	yes	10
on	on	no	n/a

The above tables show Auto-Startup Modes that can be selected by Auto Start/Delay pin combinations.

External Activity (LED) pins

The LED pins can be used to drive an external Light Emitting Diode. Please refer to the LED pin section of the Interface Specification for a detailed functional description of this pin, which is controlled by Mode Select (Page 0). Up to 33mA (5%) of TTL level LED drive capability is provided. The electronics card provides current limiting for the LED. The LED Anode may be tied to the +5V source provided on pin 18 of the Front Option Jumper Block, pin 11 of the Auxiliary connector on the 68 pin Unitized connector, or the 5V power source on the 80 pin SCA model. The LED Cathode is then

connected to the External Activity pin to complete the circuit.
Note: 68 pin and 80 pin SCA SCSI models have two sets of pins, a set on the front and a set on the back, that are connected to the same LED driver circuit. The combined drive capability is stated above.

Write Protect pin

If the Write Protect pin is jumpered to ground, SCSI commands that alter the customer data area portion of the media will not be performed. The state of this pin is monitored on a per command basis. Refer to the Interface Specification for functional details.



ATTENTION: The drive must be protected against electrostatic discharge especially when being handled. The safest way to avoid damage is to put the drive in an anti-static bag before ESD wrist straps, etc. are removed.

Drives should only be shipped in approved containers. Severe damage can be caused to the drive if the packaging does not adequately protect against the shock levels induced when a box is dropped. Consult your IBM representative if you do not have an approved shipping container.

Disable T.I. Sync. Negotiation pin

If a Disable Target Initiated Synchronous Negotiation pin is grounded, an Initiator is required to start a negotiation handshake if synchronous and/or wide (double byte) SCSI transfers are desired. Please refer to the Interface Specification for more details on this feature.

Disable SCSI Parity pin

Grounding this pin will disable SCSI Parity Checking.

Disable Unit Attention pin

Grounding this pin will disable the drive from building Unit Attention Sense information for commands immediately following a Power On Reset (POR) or SCSI Bus Reset. Any pending Unit Attention conditions will also be cleared at POR or SCSI Reset times.

Disable Wide Negotiations

Jumpering pins 31 and 32 will cause the 80 pin SCA or the 68 pin differential to operate in a single byte mode. The drive will not negotiate for wide (double byte) operation.

Mode Select options

Certain parameters are alterable using the SCSI Mode Select command. This allows certain drive characteristics to be modified to optimize performance on a particular system. Refer to the Functional Specification for a detailed definition of Mode Select parameters.

Data organization

Model	9.1GB	18.2GB
Disks	5	10
User data heads	10	20

Seek times (in milliseconds)

Single Cylinder	Read	0.7
	Write	1.5
Average (weighted)	Read	5.6
	Write	6.8
Full stroke	Read	12
	Write	13.5

User capacity for several block lengths

User bytes /logical block	User bytes /drive (9.1GB)	User bytes /drive (18.2GB)
512	9,179,493,376	18,370,117,120
514	9,202,516,192	18,416,206,230
520	9,076,016,560	18,162,921,400
522	9,104,602,896	18,220,135,950
524	9,082,973,032	18,176,834,260
528	9,132,334,464	18,275,640,240
536	9,153,823,008	18,318,612,040
732	9,497,032,416	19,005,468,660

DC power requirement limits

The following voltage specifications apply at the drive power connector. There are no special power on/off sequencing requirements.

+5 volt supply	+5% during run and spin up
+12 volt supply	+5% during run ±5 to 7% during spin up

Power supply current +5VDC

	9.1GB Pop. mean	18.2GB Pop. mean
Idle average	.76A±10%	.76A±10%

Power supply current ±12VDC

	9.1GB Pop. mean	18.2GB Pop. mean
Idle average	.66A ±10%	1.18A ±10%
Seek peak (maximum)	2.1A	2.7A
Spin-up	2.0A	3.50A

Notes:

- 5V current is given with termination power provided by the using system.
- The current at start is the total 12 volt current required (i.e. the motor start current, module current and voice coil retract current).

Externally generated ripple (as seen at power connector)

Voltage	Maximum	Notes
+5V DC	250mV peak-to-peak	0-20MHz
+12V DC	650mV peak-to-peak	0 - 100Hz
	400mV peak-to-peak	100 - 5,000Hz
	250mV peak-to-peak	5KHz - 20MHz

During drive start up and seeking, 12 volt ripple is generated by the drive (referred to as dynamic loading). If the power of several drives is daisy chained together, the power supply ripple as well as the dynamic loading of other drives must remain within the regulation tolerance window of ±5%. A more desirable method of power distribution is a common supply with separate power leads to each drive.

Hot Plug/Unplug support

The Ultrastar 9LZX & 18ZX support Hot Plug/Unplug. Refer to the Hardware Functional Specification for more details. Hot plugging the SCSI bus may cause glitches on the bus. To minimize the possibility of glitching, plug in the SCSI bus before the power is applied. The supplies must not go over the upper voltage limits during hot plugging. This means that proper ESD protection must be used during the plugging event. Be cautious not to exceed shock limits while hotplugging or unplugging.

SCSI bus connectors

68 pin SCSI signal connector

68 pin models use a Molex connector (PN 87360-0001) that is compatible with the ANSI SCSI "P" connector specifications. It can transfer data in both 8 bit (Narrow) and 16 bit (Wide) modes.

80 pin Single Connector Attachment

80 pin SCA-2 models use an AMP connector (PN 5-917593-9) that is compatible with the specification of "Single Connector Attachment for Small SCSI Disk Drives" SFF-8046 draft document, revision 2.7. It can transfer data in both 8 bit (narrow) and 16 bit (wide) modes.

Note: The SCA-2 connector is not mechanically compatible with the 68 pin "P" connector as defined in the ANSI SCSI standard. This connector is intended for direct backplane attachment and is not intended to be cable attached to the bus.

SCSI bus cable

Low Voltage Differential models permit cable lengths of up to 12 meters (39.4 feet) when operating in LVD mode. Cables must meet the requirements for LVD cables set forth in the Information Technology SCSI Parallel 2 (SPI-2) standard under "Cable Requirements".

Single-ended models permit cable lengths of up to 6 meters (19.68 feet). It should be noted however, that users who plan to use "Fast" data transfers with single-ended models should follow all of the ANSI SCSI guidelines for single-ended "Fast" operations. This may include a cable length of less than 6 meters.

SCA-2 connector models are not designed for direct cable attachment due to the combination of power and SCSI bus signals. "Fast" data transfers with SCA models should follow all of the ANSI SCSI guidelines for single-ended "Fast" operations.

Differential models permit cable lengths of up to 25 meters (82.02 feet). Cables must meet the requirements for differential cables as set forth in the ANSI SCSI standard under "Cable Requirements - Differential Cable". The ANSI SCSI standard states that any stub from the main cable must not exceed 0.1 meters for single-ended or LVD cables. The Ultrastar 9LZX & 18ZX have maximum internal stub lengths of 0.06 meters on all LVD and single-ended SCSI signals. To remain compliant with the standard, the SCSI bus cable must not add more than 0.05 meters additional stub length to any of the LVD and single-ended SCSI signals.

Models

DRVS model number	GB capacity (at 512 Byte)	SCSI pins	SCSI electrical signal type
09V	9.1	68	LVD
09D	9.1	80	LVD
		SCA-2	
18V	18.2	68	LVD
18D	18.2	80	LVD
		SCA-2	

Note: 68 pin SCSI connector models offer an 8/16 bit SCSI bus using the SCSI "P" connector which supports Wide data transfers. 80 pin SCSI connector models offer an 8/16 bit SCSI bus using the SCA-2 connector. All models support Fast and SCSI-3 Fast 20 data transfers.

SCSI bus terminators (optional)

The using system is responsible for making sure that all required signals are terminated at both ends of the cable. Active termination is not supplied on the Ultrastar 9LZX & 18ZX drives. Termination must be provided externally. Some external terminator possibilities are listed below.

68 pin model terminators

Data Mate DM2750-01-LVD (LVD only)
Amphenol 497040001 (Multimode)

SCSI bus termination power

Termination power is an option for systems that require it. In order to use the termination power, the user needs to install a jumper between pins 1 and 2 of the TermPower Block. The jumper should only be installed on one device, which should be the last device on the SCSI bus, 68 pin models can source up to 2.0 Amps of current at 5.0 Volts (+5%) for termination power.

SCSI bus termination power short circuit protection

The ANSI SCSI specification recommends devices that optionally supply TERMPWR to include current limiting protection for accidental short circuits. It also recommends that the maximum current available for TERMPWR should not exceed 2 Amps. UL has a different requirement called the 8 Amp rule. This rule states

that when a power source leaves an enclosure (like SCSI TERMPWR in the SCSI cable), it must trip 8 Amps of current within 1 minute. The drive limits current to 2.0 Amps through the use of a resettable fuse mounted on the electronics card. Systems may also provide short circuit protection for drive supplied TERMPWR by limiting the current of the 5V power it supplies to the drive.

Operating environment

The drive operates within its performance limits when the following environment is maintained. Product life calculations are based on the nominal environment for a typical application.

Humidity	
Operating	5% to 90% non-condensing
Storage	5% to 90% non-condensing
Shipping	5% to 95% (applies at the packaged level)

Wet Bulb Temperature	
Operating	80 °F (26.7 °C) maximum
Shipping/Storage	85 °F (29.4 °C) maximum

Elevation	
Operating/Storage	-1000 to 10,000 feet (-304.8 to 3,048 meters)
Shipping	-1,000 to 40,000 feet (-304.8 to 12,192 meters)

Temperature	
Operating ambient	5 to 50 °C (41 to 122 °F)
Operating disk enclosure	5 to 65 °C (41 to 149 °F)
Storage	1 to 65 °C (34 to 149 °F)
Shipping	-40 to 65 °C (-40 to 149 °F)

Temperature gradient	
Operating	36 °F (20 °C per hour)
Shipping/Storage	Below condensation

These temperature limits are extremely important and must not be exceeded at the worst case drive and system operating conditions with the drive randomly seeking, reading, and writing.

Start and stop times

Time	Nominal (sec.)	Worst case (sec.)
Model	9.1GB	9.1GB
Power Up	2.5	3
Start-Up	15.6	23.8
Spin-Up	9.5	14
Servo	5.6	4.2
Recal		
Bats2	0.5	1
/Reassign		

Time	Nominal (sec.)	Worst case (sec.)
Model	18.2GB	18.2GB
Power Up	2.5	3
Start-Up	20.9	29.1
Spin-Up	10.5	14
Servo	9.9	9.5
Recal		
Bats2	0.5	1
/Reassign		

All times in seconds.

Bring-up sequence times and stop time

See chart below.

Note: If a SCSI Reset is issued while the drive is in either a Power-Up or Startup sequence, that same sequence starts again, in all other cases when a SCSI Reset is issued, the present state of the motor is not altered.

Note: BATS is the abbreviation for Basic Assurance Tests. Start-up sequence spins up the spindle motor, uploads code, performs BATS2 (verifies read/write hardware), resumes "Reassign in Progress" operations, and more. For more information on the start-up sequence, refer to the Interface Specification.

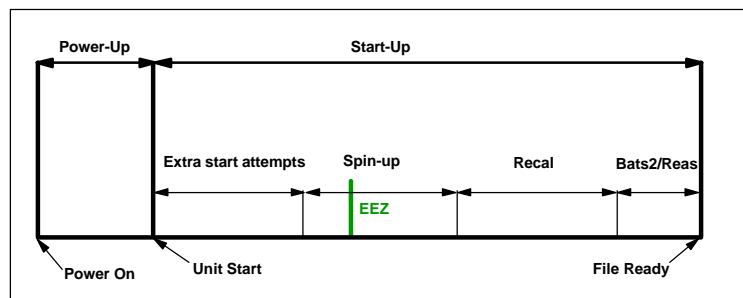

Mechanical Specifications

Weight

The 9.1GB model weighs approximately 1.46 pounds (0.67 kg), the 18.2GB model approximately 2.29 pounds (1.03 kg).

Dimensions	Inches	S.I. Metric
Height (9.1GB)	1	25.70mm
Width (9.1GB)	4	101.60mm
Depth (9.1GB)	5.75	146.75mm
Height (18.2GB)	1.63	41.48mm
Width (18.2GB)	4	101.60mm
Depth (18.2GB)	5.75	146.75mm

*Nominal weights and dimensions provided for reference only. Weight tolerance is $\pm 10\%$.

Vibration and shock

Operating/nonoperating vibration

Due to the complexity of this subject, we recommend that users contact the distributor to discuss how to perform the required measurements if they believe this to be an area which requires evaluation.

Operating shock

No permanent damage will occur to the drive when subjected to a 10 G half sine wave shock pulse of 11 ms duration. The shock pulses are applied in each of three mutually perpendicular axes, one axis at a time.

Nonoperating shock

Translational Shock

1.0" and 1.6" models will not suffer hard errors or acoustic degradation if the unpackaged drive is subjected to a 180 in/sec velocity change square pulse shock of 50 Gs or less applied to all three axes, one direction at a time.

1.0" models will not suffer hard errors or acoustic degradation if the unpackaged drive is subjected to a 2 ms half sine pulse shock of 150 Gs or less applied to all three axes, one direction at a time.

1.6" models will not suffer hard errors if the unpackaged drive is subjected to a 2 ms half sine pulse shock of 140 Gs or less applied to all three axes, one direction at a time.

Rotational Shock

The actuator will remain latched in the disk landing zone if the unpackaged drive is subjected to a

2 ms half sine wave shock less than 15,000 radians per second squared applied to the XY plane.

Clearances

A minimum of 2mm clearance should be given to the bottom surface, with the exception of a 10 mm maximum diameter area around the bottom mounting holes.

There should be 7mm of clearance between Ultrastar drives that are mounted with their top sides facing each other. Drives from other manufacturers may require additional spacing due to stray magnetic fields.

For proper cooling it is suggested that a minimum clearance of 7 mm be provided under the drive and on top of the drive.

Mounting

Refer to the Hardware/Functional Specification Drive Mounting Guidelines for more details on how to mount the drive. The diagrams below show the location of mounting holes. The drive has both side and bottom mounting holes and can be mounted with any surface facing down.

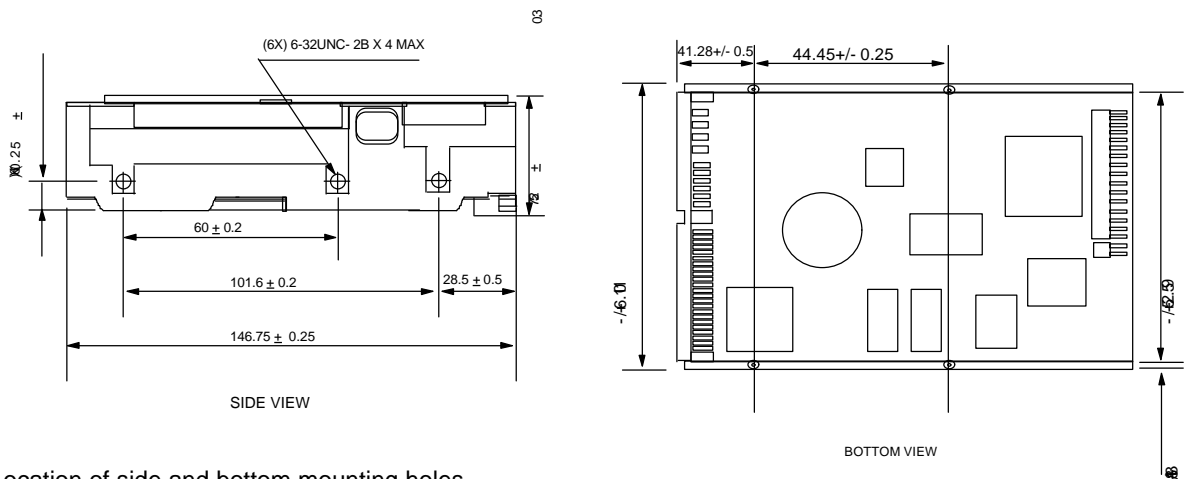

Location of side and bottom mounting holes.

Note: All measurements are in millimeters. Clearance is 7mm.

The maximum allowable penetration of the mounting screws is 4.0mm. Screws longer than 4.0mm may cause permanent damage to the drive.

The recommended torque to be applied to the mounting screws is 0.8 Newton-meters \pm 0.2 Newton-meters.

Grounding requirements of the disk enclosure

The disk enclosure is at power supply ground potential. It is allowable for the user mounting scheme to common the disk enclosure to frame ground potential or to leave it isolated from frame ground. The drive mounting frame must be within 150 millivolts of the drive's power supply ground. At no time should more than 20 milliamps of current (0 to 230 Mhz) be injected into the disk enclosure.

Temperature measurements

Following is a list of measurement points and their temperatures. Maximum temperature must not be exceeded at the worst case drive

and system operating conditions with the drive reading and writing at the maximum system operations per second rate.

	Maximum	Optimum
Disk enclosure top	149 °F (65 °C)	122 °F (50 °C)
Disk enclosure bottom	149 °F (65 °C)	122 °F (50 °C)
Channel module ¹	203 °F (95 °C)	167 °F (75 °C)
SCSI module	194 °F (90 °C)	158 °F (70 °C)
Micro-processor module	176 °F (80 °C)	140 °F (60 °C)
Controller module	194 °F (90 °C)	158 °F (70 °C)
Spindle motor driver module	194 °F (90 °C)	158 °F (70 °C)

¹ For continuous read applications, the channel module will run at higher temperatures and will require additional cooling.

Note: Maximum recommended temperatures are for nominal ambient temperature.

Module temperature measurement notes:

1. Center on the top surface of the module.
2. When making module temperature measurements, if copper tape is used to attach temperature sensors, it should be no larger than 6 mm square.
3. A thermal sensor is fitted to the electronics card. Several temperature thresholds are continuously monitored and the results updated in the drive log. This provides a thermal history and does not interrupt drive operation.

Note: The diagrams below show the location of the modules on the bottom side of the card and the measurement locations on the bottom or top of the casting.

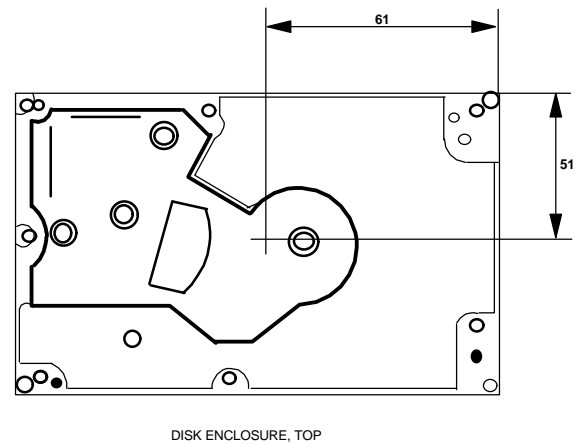
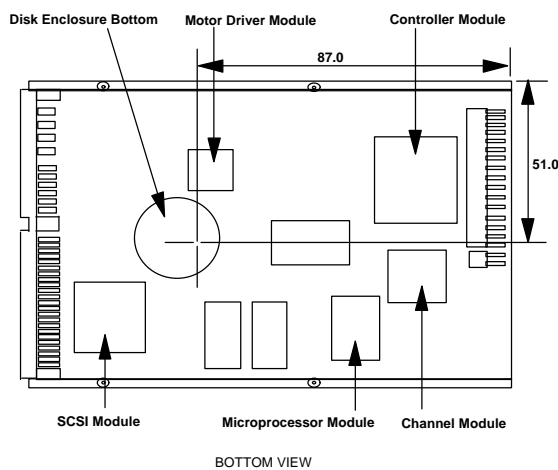



© International Business Machines Corporation 2000

www.ibm.com/harddrive

IBM Hard Disk Drive Technical Support Center

Dept. WCN
3605 Highway 52 North
Rochester, MN 55901
Telephone: 888.IBM.5214 or 507.286.5825
Fax: 507.253.DRIVE
E-mail: drive@us.ibm.com

Singapore Technical Support Center

Telephone: 1800.418.9595 or 65.6418.9595
E-mail: drive@sg.ibm.com

IBM Storage Systems Division

5600 Cottle Road
San Jose, CA 95193
www.ibm.com/storage

Asia-Pacific Headquarters: 65.320.1234

European Headquarters: 44.01.705.561.871

Japan Sales Branch Office: 81.46645.1039

Printed in the United States of America
04-2000

All Rights Reserved

IBM, No-ID, and Predictive Failure Analysis are the registered trademarks of International Business Machines Corporation.

AMP is a trademark of AMP Incorporated.
DATA MATE is a trademark of AMP Incorporated.
Molex is a trademark of Molex Incorporated.

Other company, product, and service names may be trademarks or service marks of others.

Produced by the IBM Hard Disk Drive Technical Support Center.

Hardware/Functional Specification, version 2.20
Parallel SCSI Disk Drive Logical Interface Specification, release 1.1

This product summary is not a substitute for the full production specification, which should be used when detailed information is required.

Product Description data represents IBM's design objectives and is provided for comparative purposes; actual results may vary based on a variety of factors. This product data does not constitute a warranty. Questions regarding IBM's warranty terms or methodology used to derive this data should be referred to the IBM Hard Disk Drive Technical Support Center. Data subject to change without notice.

Date: 06 April 2000