



# Quick installation guide

## Ultrastar 36LP

Ultra 160 SCSI

Models: DPSS-336950  
 DPSS-318350  
 DPSS-309170



### Handling precautions

- Do not open the electrostatic discharge (ESD) bag containing the drive until required.
- Do not apply pressure on the drive during handling or installation.
- To prevent damage from impact or vibration always set the drive down gently.
- Handle the drive carefully by the edges. Do not touch the exposed printed circuit board or any electronic components.
- Do not cover the breather hole! Covering the breather hole may result in loss of data.
- Save the packaging materials including the ESD bag in the event that the drive must be returned.

### Installing the drive

1. Backup all data.
2. Record the serial number and part number of your hard drive for future reference.
3. Turn off the computer and remove the computer system cover.
4. Before handling the hard disk drive, discharge any static electricity from yourself and your clothing. With one hand touch an unpainted metal surface on your computer chassis, then touch the ESD bag with the other hand for a minimum of two seconds. Remove the hard drive from the ESD bag.
5. Unplug the computer.
6. Assign a SCSI address to the drive by installing a jumper on one or more ID bits on jumper block J-4. Refer to the following illustrations. In the table opposite, 'X' means that a jumper is placed on that ID bit position.

### Front option jumper blocks J-4 and J-6

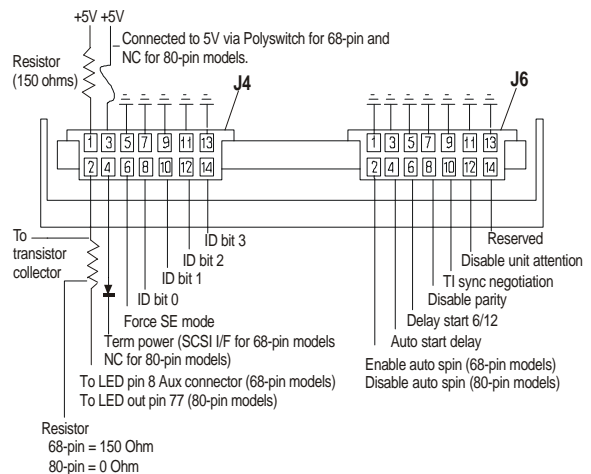

Address	Bit 0	Bit 1	Bit 2	Bit 3
0*				
1	X			
2		X		
3	X	X		
4			X	
5	X		X	
6**		X	X	
7***	X	X	X	
8				X
9	X			X
10		X		X
11	X	X		X
12			X	X
13	X		X	X
14		X	X	X
15	X	X	X	X

\* Shipping default for 80 pin models  
 \*\* Shipping default for 68 pin models  
 \*\*\* Normally reserved for host adapter

7. Select the desired options and install the appropriate jumpers.

SPECIAL NOTES:

- For this drive to operate in LVD mode all SCSI devices including the SCSI bus host adapter must be LVD devices.
  - The drive is designed to detect if the SCSI bus is LVD or SE. The drive will function based upon the mode that it detects. If for some reason the drive cannot detect a SE mode bus, place a jumper on pins 5 and 6 of jumper block J-4 to force SE mode.
  - On 68 pin drives termination power must be provided. In most cases it is provided by the host adapter. If it is not provided by the host adapter, install a jumper on pins 3 and 4 of jumper block J-4 to enable termination power. (The 80 pin drive does not provide termination power.)
8. For a 68 pin drive attach the power cable and ensure that one end of the SCSI cable is connected to the host adapter. Attach a terminator to the end of the SCSI cable furthest from the host adapter. If the drive is the only device on the SCSI cable, attach it to the cable connector closest to the terminator. Additional drives may be attached to any unused connector. (The 80 pin drive is plugged into server backplanes and requires no cables.)
  9. Using the appropriate brackets or rails, mount the drive with any of its six surfaces facing down. Retrieve any loose screws or parts from within the computer.
  10. Ensure the proper routing of cable(s).
  11. Plug in your computer. Do not turn it on.
  12. Insert the operating system (OS) setup diskette into the floppy drive.
  13. Turn on your computer.
    - If the system boots up, turn off your computer and replace the cover.
    - If your system does not boot up, turn off your computer and check all connections and settings. Turn on and boot the system.
    - If the system still fails to boot up, turn off your computer and remove the new drive to return the system to its original configuration. Contact the IBM Technology Group Support Center.

2. At the DOS prompt type **FDISK**, press [ENTER], and follow the instructions on the screen.
3. To format the primary system drive, type **FORMAT C:/S** at the DOS command prompt and press [ENTER]. The /S parameter makes C: the operating system startup drive.
4. To format a second drive (not C:), type **FORMAT X:** (where X is the drive letter assigned by FDISK) at the DOS prompt and press [ENTER].
5. Remove the diskette and restart your computer. The partitioning and formatting is complete.
6. Install the operating system.



© International Business Machines Corporation 1999

[www.ibm.com/harddrive](http://www.ibm.com/harddrive)

**IBM Technology Group Support Center**  
Telephone: 888.426.5214 or 507.286.5825  
E-mail: [drive@us.ibm.com](mailto:drive@us.ibm.com)

**Singapore Technology Group Support Center**  
Telephone: 1800.418.9595 or 65.6.418.9595  
E-mail: [drive@sg.ibm.com](mailto:drive@sg.ibm.com)

**UK Technology Group Support Center**  
Telephone: 44.1475.898.125  
E-mail: [drive@uk.ibm.com](mailto:drive@uk.ibm.com)

**Germany Technology Group Support Center**  
Telephone: 49.7032.153050  
E-mail: [drive@de.ibm.com](mailto:drive@de.ibm.com)

**IBM Systems Storage Division**  
5600 Cottle Road  
San Jose CA 95193  
[www.ibm.com/storage](http://www.ibm.com/storage)

Printed in the United States of America  
12-99  
All Rights Reserved

IBM is the registered trademark and Ultrastar is the trademark of International Business Machines Corporation.

Other company, product, and service names may be trademarks or service marks of others.

Produced by the IBM Technology Group Support Center.

Hard Disk Drive Specifications for Ultrastar 36LP (Revision 1.0)

Product Description data represents IBM's design objectives and is provided for comparative purposes; actual results may vary based on a variety of factors. This product data does not constitute a warranty. Questions regarding IBM's warranty terms or methodology used to derive this data should be referred to the IBM Technology Group Support Center. Data subject to change without notice.

Date: 9th December, 1999

---

### **Partitioning and formatting (using DOS 5.0 or later)**

*CAUTION: Partitioning and formatting will destroy any previous data. When partitioning and formatting a drive in a system with more than one drive, be sure that you select the correct hard drive.*

1. With the OS setup diskette inserted in the floppy drive, turn on the computer.