



OEM HARD DISK DRIVE SPECIFICATIONS

for

DCXA-208100 / 210000 (8 / 10 GB)

2.5-Inch Hard Disk Drive with ATA Interface

Revision (1.0)



OEM HARD DISK DRIVE SPECIFICATIONS

for

DCXA-208100 / 210000 (8 / 10 GB)

2.5-Inch Hard Disk Drive with ATA Interface

Revision (1.0)

1st Edition (0.1) S25L-2427-00 (Sep 18, 1998) Preliminary
2nd Edition (0.2) S25L-2427-01 (Oct 23, 1998) Preliminary
3rd Edition (1.0) S25L-2427-02 (Dec 11, 1998)

The following paragraph does not apply to the United Kingdom or any country where such provisions are inconsistent with local law: INTERNATIONAL BUSINESS MACHINES CORPORATION PROVIDES THIS PUBLICATION "AS IS" WITHOUT WARRANTY OF ANY KIND, EITHER EXPRESS OR IMPLIED, INCLUDING, BUT NOT LIMITED TO, THE IMPLIED WARRANTIES OF MERCHANTABILITY OR FITNESS FOR A PARTICULAR PURPOSE. Some states do not allow disclaimer or express or implied warranties in certain transactions, therefore, this statement may not apply to you.

This publication could include technical inaccuracies or typographical errors. Changes are periodically made to the information herein; these changes will be incorporated in new editions of the publication. IBM may make improvements and/or changes in the product(s) and/or the program(s) described in this publication at any time.

It is possible that this publication may contain reference to, or information about, IBM products (machines and programs), programming, or services that are not announced in your country. Such references or information must not be construed to mean that IBM intends to announce such IBM products, programming, or services in your country.

Technical information about this product is available by contacting with local IBM representative or the following.

Tel:+1-507-253-4110 / Fax:+1-507-253-4111 ----- U.S.A
Tel:+81-466-45-1441 / Fax:+81-466-45-1045 ----- Japan
Tel:+44-1705-561567 / Fax:+44-1705-210266 ----- England
Tel:+49-6131-845050 / Fax:+49-6131-846442 ----- Germany
Internet: <http://www.storage.ibm.com/oem>

IBM may have patents or pending patent applications covering subject matter in this document. The furnishing of this document does not give you any license to these patents. You can send license inquiries, in writing, to the IBM Director of Commercial Relations, IBM Corporation, Armonk, NY 10577.

© Copyright International Business Machines Corporation 1998. All rights reserved.

Note to U.S. Government Users — Documentation related to restricted rights — Use, duplication or disclosure is subject to restrictions set forth in GSA ADP Schedule Contract with IBM Corp.

Contents

1.0 General	1
1.1 Glossary	1
1.2 General Caution	1
1.2.1 Caution of usage	2
2.0 General Features	5
<hr/>	
Part 1. Functional Specification	7
3.0 Drive Characteristics	9
3.1 Logical Drive Format	9
3.2 Data Sheet	9
3.3 Performance Characteristics	10
3.3.1 Command Processing	10
3.3.2 Average Seek Time (Including Settling)	10
3.3.3 Single Track Seek Time	11
3.3.4 Full Stroke Seek	11
3.3.5 Average Latency	11
3.3.6 Drive Ready Time	12
3.3.7 Operating Modes.	13
4.0 Data Integrity	15
4.1 Data Loss by Power Off	15
4.2 Write Cache	15
4.3 Equipment Status	15
4.4 WRITE Safety	16
4.5 Data buffer test	16
4.6 Error Recovery	16
4.7 Automatic Reallocation	16
4.7.1 Non Recovered Write Errors	16
4.7.2 Non Recovered Read Errors	16
4.7.3 Recovered Read Errors	16
5.0 Specification	17
5.1 Environment	17
5.1.1 Temperature and Humidity	17
5.1.2 Magnetic Fields	18
5.2 DC Power Requirements	19
5.2.1 Start Up Current	20
5.3 Reliability	21
5.3.1 Data Reliability	21
5.3.2 Failure Prediction (S.M.A.R.T.)	21
5.3.3 Cable Noise Interference	21
5.3.4 Service Life and Usage Condition	21
5.3.5 Preventive Maintenance	21
5.3.6 Load/Unload	22
5.4 Mechanical Specifications	24
5.4.1 Mechanical Dimensions and Weight	24
5.4.2 Hole Locations	24
5.4.3 Mounting Orientation	25

5.5	Vibration and Shock	26
5.5.1	Operating Vibration	26
5.5.2	Non-Operating Vibration	26
5.5.3	Operating Shock	27
5.5.4	Non-Operating Shock	27
5.6	Acoustics	28
5.6.1	Sound Power Level	28
5.6.2	Discrete Tone Penalty	29
5.7	Identification	30
5.7.1	Labels	30
5.8	Electromagnetic Compatibility	30
5.8.1	CE Mark	30
5.8.2	C-Tick Mark	30
5.9	Safety	31
5.9.1	Underwriters Lab(UL) Approval	31
5.9.2	Canadian Standards Authority(CSA) Approval	31
5.9.3	IEC Compliance	31
5.9.4	German Safety Mark	31
5.9.5	Flammability	31
5.9.6	Secondary Circuit Protection	31
5.10	Packaging	31
6.0	Electrical Interface Specifications	33
6.1	Cabling	33
6.2	Interface Connector	33
6.2.1	Signal Definition	34
6.3	Interface Logic Signal Levels	37
6.4	Reset timings	38
6.5	PIO Timings	39
6.5.1	DMA Timings (Single Word)	40
6.5.2	DMA Timings (Multiword)	41
6.5.3	Ultra DMA Timings	42
6.6	Drive Address Setting	50
6.6.1	Default Setting	50
6.7	Addressing of drive Registers	51
<hr/>		
Part 2.	ATA Interface Specification	53
7.0	General	55
7.1	Introduction	55
7.2	Terminology	55
8.0	Deviations From Standard	57
9.0	Registers	59
9.1	Alternate Status Register	60
9.2	Command Register	60
9.3	Cylinder High Register	60
9.4	Cylinder Low Register	60
9.5	Data Register	61
9.6	Device Control Register	61
9.7	Drive Address Register	61
9.8	Device/Head Register	62
9.9	Error Register	62

9.10	Features Register	63
9.11	Sector Count Register	63
9.12	Sector Number Register	63
9.13	Status Register	63
10.0	General Operation Descriptions	65
10.1	Reset Response	65
10.1.1	Register Initialization	67
10.2	Diagnostic and Reset considerations	68
10.3	Sector Addressing Mode	69
10.3.1	Logical CHS Addressing Mode	69
10.3.2	LBA Addressing Mode	69
10.4	Power Management Feature	70
10.4.1	Power Mode	70
10.4.2	Power Management Commands	70
10.4.3	Standby/Sleep command completion timing	70
10.4.4	Standby timer	71
10.4.5	Status	71
10.4.6	Interface Capability for Power Modes	71
10.4.7	Initial Power Mode at Power On	71
10.5	Advanced Power Management Feature (ABLE-3)	72
10.5.1	Performance Idle mode	72
10.5.2	Active Idle mode	72
10.5.3	Low Power Idle mode	72
10.5.4	Transition Time	72
10.6	S.M.A.R.T. Function	74
10.6.1	Attributes	74
10.6.2	Attribute values	74
10.6.3	Attribute thresholds	74
10.6.4	Threshold exceeded condition	74
10.6.5	S.M.A.R.T. commands	74
10.6.6	S.M.A.R.T. operation with power management modes	75
10.7	Security Mode Feature Set	76
10.7.1	Security mode	76
10.7.2	Security level	76
10.7.3	Password	76
10.7.4	Operation example	77
10.7.5	Command Table	80
10.8	Protected Area Function	82
10.8.1	Example for operation (In LBA mode)	82
10.9	Address Offset Feature (Vendor Specific)	84
10.9.1	Enable/Disable Address Offset Mode	84
10.9.2	Identify Device Data	85
10.9.3	Exceptions in Address Offset Mode	85
10.10	Write Cache Function	86
10.11	Reassign Function	87
10.11.1	Auto Reassign Function	87
11.0	Command Protocol	89
11.1	Data In Commands	89
11.2	Data Out Commands	90
11.3	Non-Data Commands	92
11.4	DMA Data Transfer Commands	93
12.0	Command Descriptions	95

12.1	Check Power Mode (E5h/98h)	99
12.2	Execute Device Diagnostic (90h)	100
12.3	Flush Cache (E7h)	101
12.4	Format Track (50h: Vendor Specific)	102
12.5	Format Unit (F7h: Vendor Specific)	104
12.6	Identify Device (ECh)	106
12.7	Identify Device DMA (EEh)	112
12.8	Idle (E3h/97h)	113
12.9	Idle Immediate (E1h/95h)	114
12.10	Initialize Device Parameters (91h)	115
12.11	Read Buffer (E4h)	116
12.12	Read DMA (C8h/C9h)	117
12.13	Read Long (22h/23h)	119
12.14	Read Multiple (C4h)	121
12.15	Read Native Max Address (F8h)	123
12.16	Read Sectors (20h/21h)	125
12.17	Read Verify Sectors (40h/41h)	127
12.18	Recalibrate (1xh)	129
12.19	Security Disable Password (F6h)	130
12.20	Security Erase Prepare (F3h)	131
12.21	Security Erase Unit (F4h)	132
12.22	Security Freeze Lock (F5h)	134
12.23	Security Set Password (F1h)	135
12.24	Security Unlock (F2h)	137
12.25	Seek (7xh)	139
12.26	Set Features (EFh)	140
12.27	Set Max Address (F9h)	142
12.28	Set Multiple (C6h)	144
12.29	Sleep (E6h/99h)	145
12.30	S.M.A.R.T. Function Set (B0h)	146
12.30.2	Device Attributes Data Structure	149
12.30.3	Device Attribute Thresholds Data Structure	155
12.30.4	Error Reporting	157
12.31	Standby (E2h/96h)	159
12.32	Standby Immediate (E0h/94h)	160
12.33	Write Buffer (E8h)	161
12.34	Write DMA (CAh/CBh)	162
12.35	Write Long (32h/33h)	164
12.36	Write Multiple (C5h)	166
12.37	Write Sectors (30h/31h)	168
12.38	Write Verify (3Ch: Vendor Specific)	170
13.0	Timeout Values	171
14.0	Appendix	173
14.1	Commands Support Coverage	173
14.2	SET FEATURES Command Support Coverage	175
Index		177

1.0 General

This document describes the specifications of the following IBM 2.5-inch, ATA interface hard disk drives:

- DCXA-208100 (8190 MB)
- DCXA-210000 (10050 MB)

Note: The specifications are subject to change without notice.

1.1 Glossary

<i>Word</i>	<i>Meaning</i>
Kbpi	1 000 Bit Per Inch
Mbps	1 000 000 Bit per second
GB	1 000 000 000 bytes
MB	1 000 000 bytes
KB	1 000 bytes
32 KB	32 x 1 024 bytes
64 KB	64 x 1 024 bytes
Mb/sq.in	1 000 000 bits per square inch
MLC	Machine Level Control
DFT	Drive Fitness Test
TBD	To Be Defined

1.2 General Caution

- Do not apply pressing force on the top cover (See Figure 1 on page 2).
- Do not cover the breathing hole on the top cover (See Figure 2 on page 3).
- Do not touch the interface connector pins and the surface of printed circuit board.
- The drive can be easily damaged by shocks or ESD (Electric Static Discharge), so any damages applied to the drive after taking out from shipping package and opening ESD protective bag are user's responsibilities.

1.2.1 Caution of usage

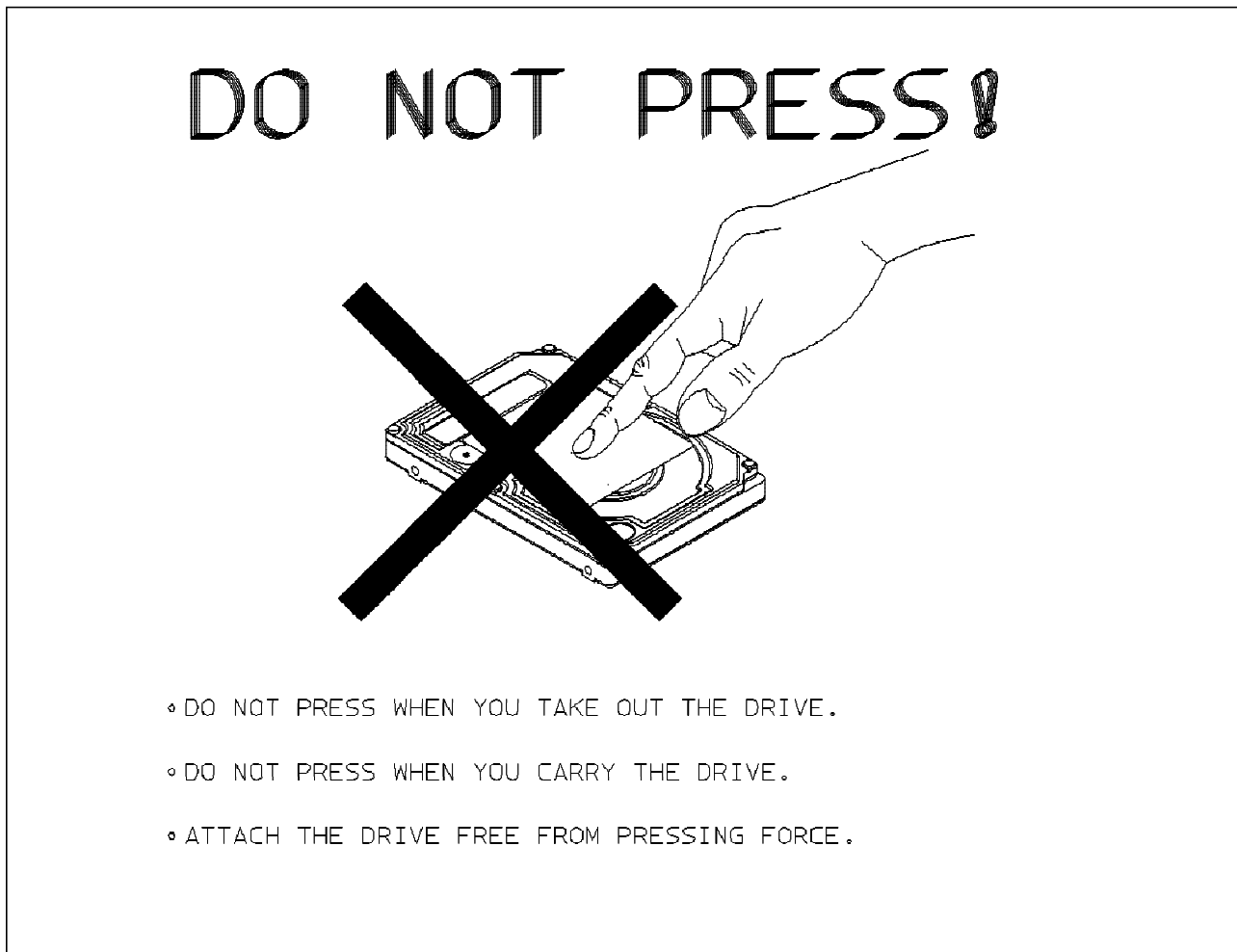
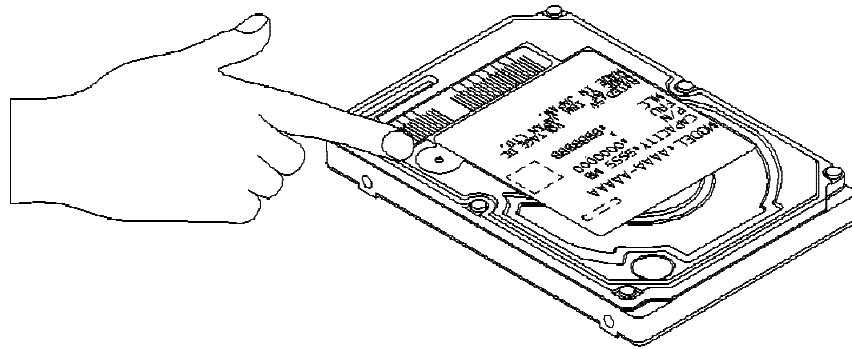

Figure 1. Handling caution of DCXA-208100 / 210000

DO NOT COVER THIS HOLE



COVERING THIS HOLE WILL RESULT LOSS OF DATA.

Figure 2. Breathing hole caution of DCXA-208100 / 210000

2.0 General Features

- 2.5-inch, 12.5mm Height MCC Compliance
- 10050MB / 8190MB formatted capacity
- 512 bytes/sector
- AT Interface (Enhanced IDE) conforming to ATA-4
- Integrated controller
- No-ID recording format
- PRML channel
- Multi Zone Recording
- On The Fly correction : 12 Bytes/sector
- 420KB Segmented Buffer for Read and Write
- Host data transfer speed.
 - 16.6 MB/sec : PIO Mode-4
 - 33.3 MB/sec : Ultra DMA Mode-2
- Media data transfer rate 118.0 (outer zone) - 69.0 (inner zone) Mbit/sec
- Average seek time 12 milliseconds for read
- Closed-loop actuator servo (Embedded Sector Servo)
- Rotary voice coil motor actuator
- Load / Unload mechanism
- Adaptive power save control (0.65 Watt at low-power idle state)
- 2.8 sec Power on to ready
- Shock
 - Non-operation : 600G/2ms
 - Operation : 125G/2ms
- Address Offset Feature to support DFT implementation

Note: Mounting screw position is

- Incompatible with DBOA/DMCA/DCRA/DSOA/DPRA-2xxxx.
- Compatible with DTNA/DLGA/DDLA/DTCA/DPLA/DYKA/DYLA/DADA/
DKLA/DBCA/DCYA-2xxxxx.

Part 1. Functional Specification

3.0 Drive Characteristics

This chapter provides the characteristics of the drives.

3.1 Logical Drive Format

The customer usable data capacity is as shown below.

Figure 3. Drive Parameter		
Descriptions	DCXA-208100	DCXA-210000
Logical Head Number	16	16
Logical Sectors/Track	63	63
Logical Cylinder Number	15880	16383
Logical Sector Size	512	512
Total Customer Usable Data Sectors	16,007,040	19,640,880
Total Customer Usable Data Bytes	8190 MB 8,195,604,480	10050 MB 10,056,130,560

3.2 Data Sheet

Figure 4. Data Sheet	
Media transfer rate [Mb/sec]	69.0 - 118.0
Interface transfer rate [MB/sec]	33.3 MB/sec Max (Ultra DMA Mode-2) 16.6 MB/sec Max (PIO-4)
Data buffer size [KB]	420 KB (Read / Write)
Rotational speed [RPM]	4200
Average latency [msec]	7.1
Recording density [Kbpi]	283.2 Maximum
Track density [TPI]	19,900
Areal density [Gb/sq.in.]	5.6 Maximum
Number of zone	12
Number of disks	3
Number of heads	5 / 6
Servo design method	Embedded sector servo

3.3 Performance Characteristics

File performance is characterized by the following parameters:

- Command Overhead
- Mechanical Positioning
 - Seek Time
 - Latency
- Data Transfer Speed
- Buffering Operation

Note: All the above parameters contribute to a file performance. There are other parameters which contribute to the performance on the actual system. This specification tries to define the essential file characteristics, not the system throughput which is dependent on the system and the application.

The following table gives a **typical value** of each parameter. The detail descriptions are followed in the next sections.

Function	Typical
Average Random Seek Time For Read	12 msec
Average Random Seek Time For Write	14 msec
Rotational Speed	4200 rpm
Power On To Ready	2.8 sec
Command Overhead	1.0 msec
Disk-Buffer Data Transfer	118.0 - 69.0 Mbit/sec
Buffer-Host Data Transfer	16.6 MB/sec (PIO Mode-4) 33.3 MB/sec (Ultra DMA Mode-2)

Figure 5. Performance Parameter

3.3.1 Command Processing

Command overhead time is defined as the total time from when the command is received by the drive to the start of motion of the actuator.

3.3.2 Average Seek Time (Including Settling)

Command Type	Typical	Max
Read	12 msec	16 msec
Write	14 msec	17 msec

Figure 6. Mechanical Positioning Performance

'Typical' and 'Max' are given throughout the performance specification by;

Typical Average of the drive population tested at nominal environmental and voltage conditions.

Max Maximum value measured on any one drive over the full range of the environmental and voltage conditions. (See section on Environment and D.C. Power Requirements.)

The seek time is measured from the start of motion of the actuator to the start of a **reliable read or write operation**. Reliable read or write implies that error correction/recovery is not employed to correct for arrival problems. The Average Seek Time is measured as the weighted average of all possible seek combinations.

$$\text{Weighted Average} = \frac{\sum_{n=1}^{\text{max}} (\text{max} + 1 - n) (\text{Tn.in} + \text{Tn.out})}{(\text{max} + 1) (\text{max})}$$

Where:

- max = Maximum Seek Length
- n = Seek Length (1 to max)
- Tn.in = Inward measured seek time for a n track seek
- Tn.out = Outward measured seek time for a n track seek

3.3.3 Single Track Seek Time

Function	Typical	Max
READ	2.5 msec	4.0 msec
Write	3.0 msec	4.5 msec

Figure 7. Single Track Seek Time

The single track seek time includes settling time but does not include command overhead.

Single track seek is measured as the average of one (1) single track seek from every track in both directions (inward and outward).

3.3.4 Full Stroke Seek

Function	Typical	Max
Read	23.0 msec	30.0 msec
Write	24.0 msec	31.0 msec

Figure 8. Full Stroke Seek Time

Full stroke seek is measured as the average of 1000 full stroke seeks.

3.3.5 Average Latency

RPM	Time for a revolution	Average Latency
4200	14.3 msec	7.1 msec

Figure 9. Latency Time

3.3.6 Drive Ready Time

Condition	Typical	Max
Power On To Ready	2.8 sec	9.5 sec

Figure 10. Drive Ready Time

- Ready** The condition in which the drive is able to perform a media access command (e.g. read, write) immediately.
- Power On** This includes the time required for the internal self diagnostics.

3.3.7 Operating Modes.

Operating mode	Description
Spin-Up	: Start up time period from spindle stop or power down.
Seek	: Seek operation mode
Write	: Write operation mode
Read	: Read operation mode
Performance idle	: The device is capable of responding immediately to media access requests. All electronic components remain powered and full frequency servo remains operational.
Active idle	: The device is capable of responding immediately to media access requests. Some circuitry including servo system and R/W electronics are in power saving mode. The head is parked near the mid-diameter of disk without servoing. A device in Active idle mode may take longer to complete the execution of a command because it has to activate that circuitry.
Low power idle	: Head is unloaded on the ramp position. Spindle motor is rotating at full speed.
Standby	: The device interface is capable of accepting commands. Spindle motor is stopped. All circuitry except host interface are in power saving mode. The execution of commands is delayed until spindle becomes ready.
Sleep	: The device requires a soft reset or a hard reset to be activated. All electronics including spindle motor and host interface are shut off.

Figure 11. Operating Mode

3.3.7.1 Mode Transition Time.

From	To	Transition Time
Standby	Idle	1.8 sec typ, 9.5 sec max.

Figure 12. Mode Transition Time

3.3.7.2 Operating mode at power on

The device goes to Idle mode after power on or hard reset as an initial state. Initial state may be changed to Standby mode using pin C on the interface connector. Refer to 6.6, “ Drive Address Setting” on page 50 for detail.

3.3.7.3 Adaptive power save control

The transient timing from active mode to Idle mode is adaptively controlled to the access pattern of the host system.

4.0 Data Integrity

4.1 Data Loss by Power Off

- The drive retains recorded data under all non-write operations.
- No more than one sector can be lost by power down during write operation while write cache is disabled.
- Power off during write operation may make an incomplete sector which will report hard data error when read. The sector can be recovered by a re-write operation.
- Hard reset does not cause any data loss.

4.2 Write Cache

- Power off while write cache is enabled may cause loss of data which are remaining in the cache and have not been flushed onto the disk media.
This means that there is a possibility that power off even after write command completion may cause loss of data.
- There are ways to check if all data in the write cache have been flushed onto the disk. Checking just before power off is recommended to prevent data loss.
 - To confirm successful completion of Software Reset.
 - To confirm successful completion of Flush Cache command.
 - To confirm successful completion of Check Power Mode command.
 - To confirm successful completion of Standby command.
 - To confirm successful completion of Standby Immediate command.
 - To confirm successful completion of Sleep command.

Note: For **Power Off Sequence**, refer to 5.3.6, “Load/Unload” on page 22.

4.3 Equipment Status

Equipment status is available to the host system any time the drive is not ready to read, write, or seek. This status normally exists at power-on time and will be maintained until the following conditions are satisfied:

- Access recalibration/tuning is complete.
- Spindle speed meets requirements for reliable operation.
- Self-check of drive is complete.

Appropriate error status is made available to the host system if any of the following conditions occur after the drive has once become ready:

- Spindle speed outside requirements for reliable operation.
- Occurrence of a Write Fault condition.

4.4 WRITE Safety

The drive ensures that the data is written into the disk media properly. Following conditions are monitored during a write operation. When one of those conditions exceeds the criteria, the write operation is terminated and automatic retry sequence will be invoked.

- Head off track
- External shock
- Low supply voltage
- Spindle speed tolerance

4.5 Data buffer test

The data buffer is tested at Power-on-reset and when a drive self-test is requested by the host. The tests are consisted of write/read '00'x and 'ff'x pattern on all buffer.

4.6 Error Recovery

Errors occurring on the drive are handled by the error recovery procedure.

Errors that are uncorrectable after application of the error recovery procedures are reported to the host system as non-recoverable errors.

4.7 Automatic Reallocation

The sectors that show some errors may be reallocated automatically when specific conditions are met. The drive does not report for auto-reallocation to the host system. The conditions for auto-reallocation are described below.

4.7.1 Non Recovered Write Errors

When a write operation can not be completed after the Error Recovery Procedure (ERP) is fully carried out, the sector(s) are reallocated to the spare location. An error is reported to the host system only when the write cache is disabled and the auto reallocation is failed.

4.7.2 Non Recovered Read Errors

When a read operation is failed after defined ERP is fully carried out, a hard error is reported to the host system. This location is registered internally as a candidate for the reallocation. When a registered location is specified as a target of a write operation, a sequence of media verification is performed automatically. When the result of this verification meets the criteria, this sector is reallocated.

4.7.3 Recovered Read Errors

When a read operation for a sector failed once then recovered at the specific ERP step, this sector is reallocated automatically. A media verification sequence may be run prior to the reallocation according to the pre-defined conditions.

5.0 Specification

5.1 Environment

5.1.1 Temperature and Humidity

Figure 13. Environmental Condition	
Operating Conditions	
Temperature	5 to 55 [°C] (See note)
Relative Humidity	8 to 90 [% RH]
Maximum Wet Bulb Temperature	29.4 [°C]
Maximum Temperature Gradient	20 [°C/Hour]
Altitude	-300 to 3000 [m]
Non-Operating Conditions	
Temperature	-40 to 65 [°C]
Relative Humidity	5 to 95 [% RH]
Maximum Wet Bulb Temperature	40 [°C]
Maximum Temperature Gradient	20 [°C/Hour]
Altitude	-300 to 12,000 [m]
Note:	
The system has to provide sufficient ventilation to maintain a surface temperature below 60 °C at the center of the top cover of the drive.	
Non-condensing should be kept at any time.	
Maximum storage period with shipping package is one year.	

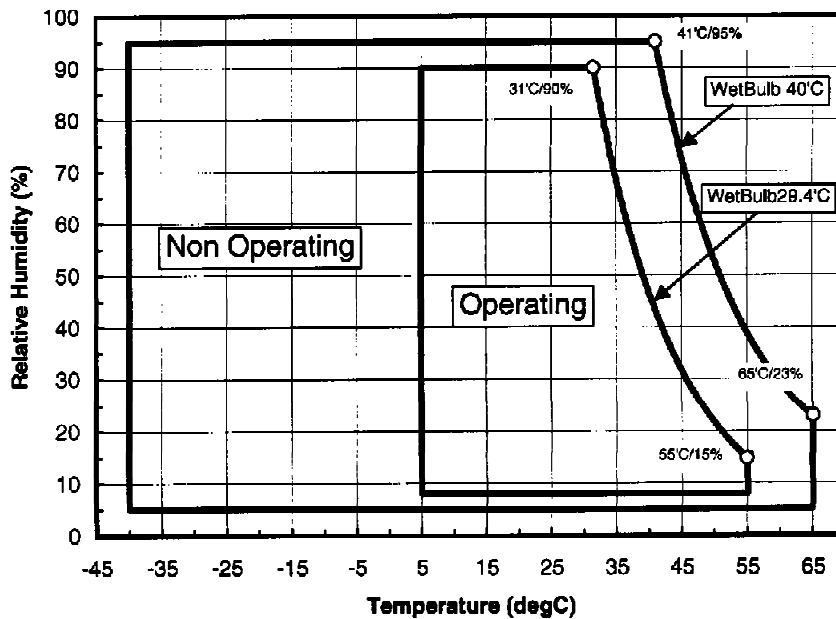

Figure 14. Limits of Temperature and Humidity

5.1.2 Magnetic Fields

The disk drive will withstand radiation & conductive noise within the limits shown below.

5.1.2.1 Radiation Noise

The disk drive shall work without degradation of the soft error rate under the following Magnetic Flux Density Limits at the enclosure surface.

Frequency (KHz)	Limits (Gauss rms)
0 - 60	5.0
61 - 100	2.5
101 - 200	1.0
201 - 400	0.5

Figure 15. Magnetic Flux Density Limits

5.1.2.2 Conductive Noise

The disk drive shall work without degradation of the soft error rate, with an AC current of up to 45 mA(p-p), in the frequency range from DC to 20 MHz, injected through any two of the mounting screw holes of the drive via 50ohm resistor.

5.2 DC Power Requirements

Connection to the product should be made in isolated secondary circuits (SELV). The voltage specifications are applied at the power connector of the drive.

Item	Requirements	Notes
Nominal Supply	+ 5 Volt	
Power Supply Ripple (0- 20Mhz)	100 mv p-p max	*1
Tolerance	+/- 5 %	*2
Supply Current	Pop.Mean (Nominal Condition)	
Low-power Idle Average	0.13 A RMS typical (0.65 W)	
Active Idle Average	0.19 A RMS typical (0.95 W)	
Performance Idle Average	0.37 A RMS typical (1.85 W)	*3
Read average	0.42 A RMS typical (2.1 W)	*4
Write average	0.44 A RMS typical (2.2 W)	
Seek average	0.46 A RMS typical (2.3 W)	*5
Standby	0.05 A RMS typical (0.25 W)	
Sleep	0.02 A RMS typical (0.1 W)	
Start up(maximum peak)	0.94 A RMS typical (4.7 W)	*6
(average from power on to ready)	0.66 A RMS typical (3.3 W)	
Supply Rise Time	7 - 100 ms	

Figure 16. Power Requirement

Notes:

- (*1) The maximum fixed disk ripple is measured at 5V input of the drive.
- (*2) The disk drive shall not incur damage for an over voltage condition of +25 % (maximum duration of 20 ms) on the 5-volt nominal supply.
- (*3) The idle current is specified at an inner track.
- (*4) The read/write current is specified based on three operations of 63 sector read/write per 100 msec.
- (*5) The seek average current is specified based on three operations per 100 msec.
- (*6) The typical current wave form at start up is shown in Figure 17 on page 20.

5.2.1 Start Up Current

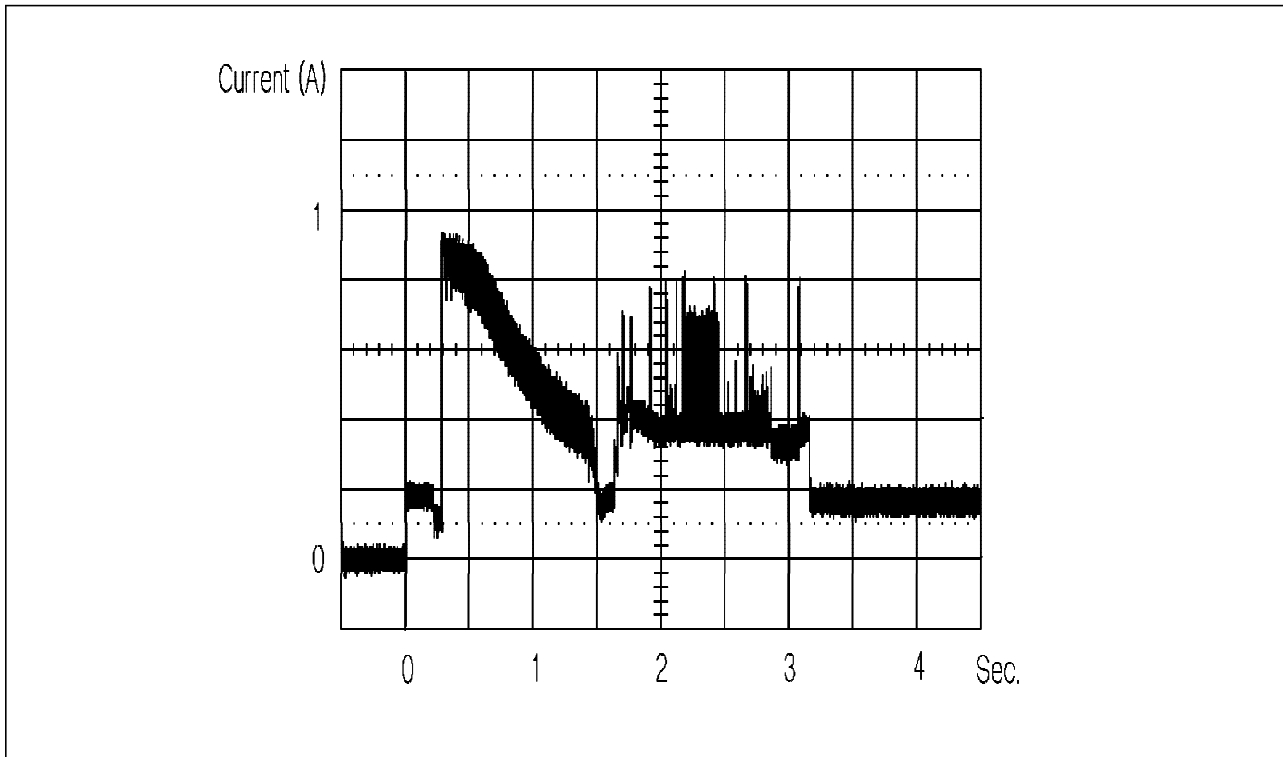

Figure 17. Typical current wave form at start up.

5.3 Reliability

5.3.1 Data Reliability

- Probability of not recovering data 1 in 10¹³ bits read
- ECC implementation
 - On-The-Fly correction, performed as a part of read channel function, recovers up to 9 symbols of error in 1 sector. (1 symbol is 8 bits.)
 - Off-line correction, performed as a part of retry procedure in the drive, recovers up to 12 symbols of error in 1 sector.

5.3.2 Failure Prediction (S.M.A.R.T.)

DCXA-2xxxxx supports S.M.A.R.T. function. The details are described in 10.6, “S.M.A.R.T. Function” on page 74 and 12.30, “S.M.A.R.T. Function Set (B0h)” on page 146.

5.3.3 Cable Noise Interference

To avoid any degradation of performance throughput or error when the interface cable is routed on top or comes in contact with the HDA assembly, the drive must be grounded electrically to the system frame by four screws. The common mode noise or voltage level difference between the system frame and power cable ground or AT interface cable ground should be in the allowable level specified in the power requirement section.

5.3.4 Service Life and Usage Condition

The drive is designed to be used under the following conditions.

- Within specifications of Shock, Vibration, Temperature, Humidity, Altitude, and Magnetic Field.
- ESD protective handling.
- Without covering breathing hole on top cover.
- Without pressing top cover.
- Less than 250 power-on hours per month.
- Seeking/Writing/Reading operation be less than 20% of power-on hours.
- The power requirements be satisfied.
- Drive frame be grounded electrically to the system through four screws.
- Mounting with recommended screw depth and torque.
- Interface physical and electrical requirements be satisfied per ATA-4.
- Power off sequence according to 5.3.6.2, “ Required Power-Off Sequence” on page 22.

Service life of DCXA-2xxxxx is approximately 5 years or 15,000 power-on hours, whichever comes first.¹

Actual product life and failure rate depend on duty cycle and environmental conditions.

Consult your IBM representative for reliability estimate if atypical operating conditions are anticipated.

5.3.5 Preventive Maintenance

None.

¹ This does not represent any warranty nor warranty period. Applicable warranty and warranty period are covered by purchase agreement.

5.3.6 Load/Unload

The product supports a minimum of 300,000 normal load/unloads.

Load/unload is a functional mechanism of the HDD. It is controlled by the drive microcode. Specifically, unloading of the heads is invoked by the commands:

- Soft Reset
- Standby
- Standby Immediate
- Sleep

Load/unload is also invoked as one of the idle modes of the drive.

The specified start/stop life of the product assumes that load/unload is operated normally, **not in emergency mode**.

5.3.6.1 Emergency Unload

When HDD power is interrupted while the heads are still loaded, the microcode cannot operate and the normal 5v power is unavailable to unload the heads. In this case, normal unload is not possible, so the heads are unloaded by routing the back-EMF of the spinning motor to the voice coil. The actuator velocity is greater than the normal case, and the unload process is inherently less controllable without a normal seek current profile.

Emergency unload is intended to be invoked in rare situations. Because this operation is inherently uncontrolled, it is more mechanically stressful than a normal unload.

DCXA-2xxxxx supports a minimum of 20,000 emergency unloads.

5.3.6.2 Required Power-Off Sequence

The required BIOS sequence for removing power from DCXA-2xxxxx is:

- Step 1: Issue one of the following commands.
 - Soft Reset
 - Standby
 - Standby Immediate
 - Sleep

Note: Do **not** use Flush Cache command for power off sequence, because the command does not invoke Unload.

- Step 2: **Wait** until **Command Complete** Status is returned.

In typical case, it takes 350ms for the command completion, however, BIOS time out value needs to be 30sec considering error recovery time. Refer to 13.0, “Timeout Values” on page 171 for time out values.

- Step 3: Terminate power to HDD.

This power-down sequence should be followed for entry into any system power-down state, or system suspend state, or system hibernation state. In a robustly designed system, emergency unload is limited to rare scenarios such as battery removal during operation.

5.3.6.3 Power Switch Design Considerations

In systems that use DCXA-2xxxxx consideration should be given to the design of the system power switch.

IBM recommends that the switch operate under control of the Bios, as opposed to being 'hard wired'. The same recommendation is made for 'cover-close' switches. When a hard wired switch is turned off, emergency unload occurs, as well as the problems cited in 4.1, "Data Loss by Power Off" on page 15 and 4.2, "Write Cache" on page 15.

5.3.6.4 Test Considerations

Start/stop testing is classically performed to verify head/disk durability. In the case of DCXA-2xxxxx the heads do not land on the disk, so this type of test should be viewed as a test of the load/unload function.

Start/Stop testing should be done **by commands** through the interface, **Not by power cycling** the drive. Simple power cycling of DCXA-2xxxxx invokes the emergency unload mechanism, and subjects the HDD to non-typical mechanical stress.

Power cycling testing may be required to test the boot-up function of the system. In this case IBM recommends that the power-off portion of the cycle contain the sequence specified in 5.3.6.2, "Required Power-Off Sequence" on page 22. Again, if this is not done, the emergency unload function is invoked and non-typical stress results.

5.4 Mechanical Specifications

5.4.1 Mechanical Dimensions and Weight

The following chart describes the dimensions for the 2.5" hard disk drive form factor.

	DCXA-208100 / DCXA-210000
Height (mm)	12.7 +0.0/-0.5
Width (mm)	69.85 ± 0.25
Length (mm)	100.2 ± 0.25
Weight (gram)	137 Typical (140 Max)

Figure 18. Physical Dimension and Weight

5.4.2 Hole Locations

The Figure 19 on page 24 shows the outline of DCXA-2xxxxx which includes the hole locations.

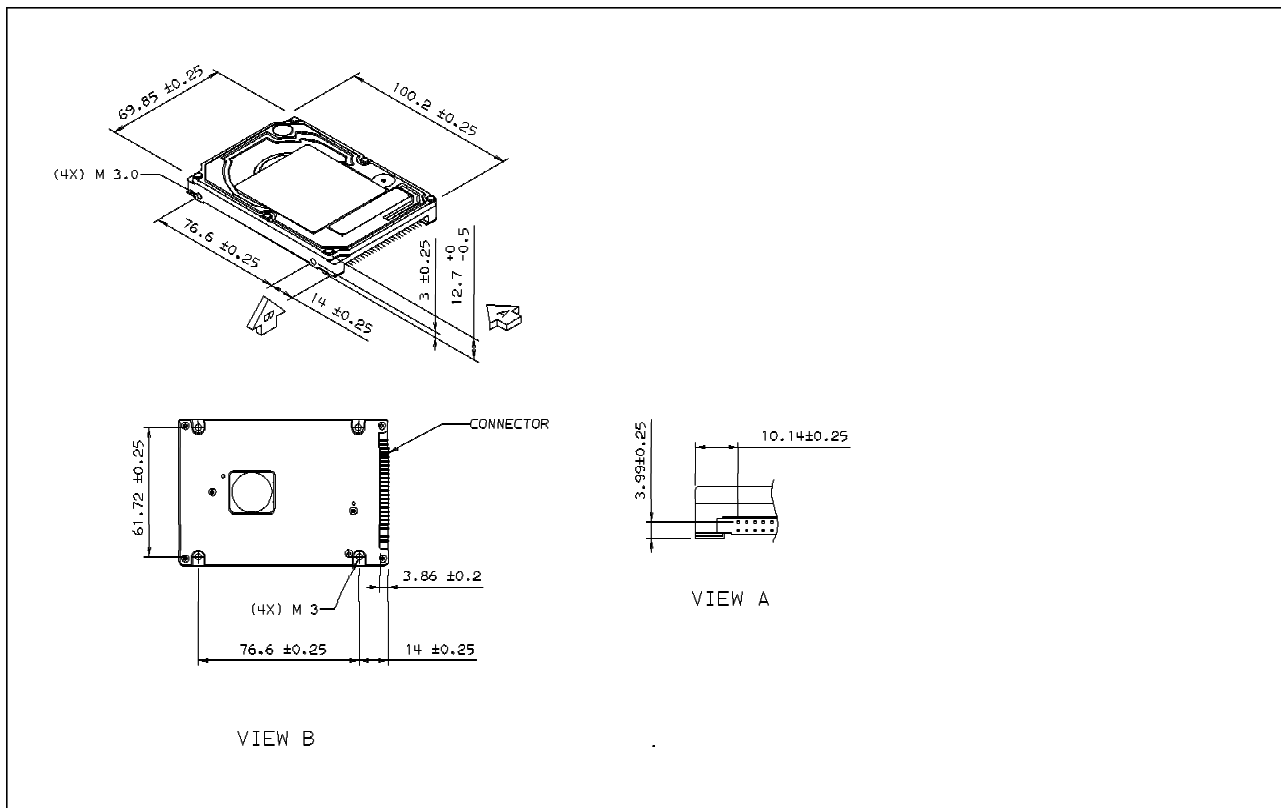

Figure 19. Outline of DCXA-2xxxxx

5.4.3 Mounting Orientation

The drive will operate in all axes (6 directions). The drive will operate within the specified error rates when tilted ± 5 degree from these positions.

Performance and error rate will stay within specification limits if the drive is operated in the other permissible orientations from which it was formatted. Thus a drive formatted in a horizontal orientation will be able to run vertically and vice versa.

The recommended mounting screw torque is 3.0 +/- 0.5 kgf.cm.

The recommended mounting screw depth is 3.0 +/- 0.3 mm for bottom and 3.5 +/- 0.5 mm for horizontal mounting.

The system is responsible for mounting the drive securely enough to prevent excessive motion or vibration of the drive at seek operation or spindle rotation, using appropriate screws or equivalent mounting hardware.

5.5 Vibration and Shock

All vibration and shock measurements in this section shall be for the disk drive without the mounting attachments for the systems. The input level shall be applied to the normal drive mounting points. Vibration test and shock test are to be conducted by mounting the drive to the table using the bottom four screws.

5.5.1 Operating Vibration

The disk drive will operate without a hard error while being subjected to the following vibration levels.

5.5.1.1 Random Vibration

The measurements are carried out with vibration test level 0.67G RMS (Root Mean Square) during 30 minutes of random vibration using the power spectrum density (PSD) as follows.

Random vibration PSD profile Breakpoint

5 Hz	2.0 x E-5	g**2/Hz
17 Hz	1.1 x E-3	
45 Hz	1.1 x E-3	
48 Hz	8.0 x E-3	
62 Hz	8.0 x E-3	
65 Hz	1.0 x E-3	
150 Hz	1.0 x E-3	
200 Hz	5.0 x E-4	
500 Hz	5.0 x E-4	

The specified levels are measured at the mounting points.

5.5.1.2 Swept Sine Vibration

- 1 G (Zero to peak), 5 to 500 to 5 Hz sine wave
- 2.0 oct/min sweep rate

5.5.2 Non-Operating Vibration

5.5.2.1 Random Vibration

The test consists of a random vibration applied in each of three mutually perpendicular axes with the time duration of 15 minutes per axis. The PSD levels for the test simulates the shipping and relocation environment which is shown below.

Hz	Random Vibration PSD Profile Breakpoints (Non-Operating)			
Hz	2.5	5	40	500
G**2/Hz	0.001	0.03	0.018	0.018

Overall RMS level of vibration is 3.01G (RMS).

5.5.2.2 Swept Sine Vibration

- 25.4mm (peak to peak) displacement, 5 to 10 to 5 Hz
- 5 G (zero to peak), 10 to 500 to 10 Hz sine wave
- 0.5 oct/min sweep rate

5.5.3 Operating Shock

The hard disk drive meets the following criteria while operating in the conditions described below. The shock test consists of ten shock inputs in each axis and direction for a total of 60. There must be a minimum 3 seconds delay between shock pulses. Soft errors and automatic retries are allowed during the test.

No data loss or permanent damage : 125G/2msec half-sine shock pulse, 10G/11msec half-sine shock pulse

The input level shall be applied to the normal disk drive subsystem mounting points, as mounted in normal system use.

5.5.4 Non-Operating Shock

The disk drive must withstand with no damage or degradation of performance, a 120G half-sine wave shock pulse of 11 ms duration and a 600G half-sine wave shock pulse of 1 ms duration on six sides when heads are parked. (When the power is not applied to the unit, the heads are automatically located on the parked position.)

All shocks shall be applied in each direction of the drive's three mutually perpendicular axes, one axis at a time. Input levels shall be measured at the frame of the disk drive.

5.6 Acoustics

5.6.1 Sound Power Level

The criteria of A-weighted sound power level is described below.

Measurements are to be taken in accordance with ISO 7779. The mean of 40 drives is to be less than the typical value. Each drive is to be less than the maximum value. Drives are to meet this requirement in both board down orientations.

A-weighted Sound Power (Bels)	Typical	Maximum
Idle	3.3	3.6
Operating	3.6	3.9

Background power levels of the acoustic test chamber for each octave band are to be recorded.

Sound power tests are to be conducted with the drive supported by spacers so that the lower surface of the drive be located at 25 +/- 3mm height from the chamber floor. No sound absorbing material shall be used.

The acoustical characteristics of the disk drive are measured under the following conditions.

Idle mode :

Power on, disks spinning, track following, unit ready to receive and respond to control line commands.

Operating mode :

Continuous random cylinder selection and seek operation of actuator with a dwell time at each cylinder. Seek rate for the drive can be calculated as shown below.

$$N_s = 0.4 / (T_t + T_1)$$

where:

- N_s : Average seek rate in seeks/s.
 T_t : Published seek time from one random track to another without including rotational latency.
 T_1 : Equivalent time, in seconds, for the drive to rotate by half a revolution.

5.6.2 Discrete Tone Penalty

Discrete tone penalties are added to the A-weighted sound power (L_w) with following formula only when determining compliance.

$$L_{wt(spec)} = L_w + 0.1 * P_t + 0.3 < 4.0 \text{ (Bels)}$$

where:

L_w : A-weighted sound power level.

P_t : Value of discrete tone penalty = $dL_t - 6.0$ (dBA)

dL_t : Tone-to-noise ratio taken in accordance with ISO 7779. at each octave band.

5.7 Identification

5.7.1 Labels

The following labels are affixed to every disk drive .

1. A label placed on the top of the HDA containing the statement 'Made by IBM' or equivalent, Part No., EC No. and FRU No.
2. A bar code label placed on the disk drive based on user request. The location on the disk drive is to be designated in the drawing.
3. Labels containing the vendor's name, disk drive model number, serial number, place of manufacture and UL/CSA logos.

5.8 Electromagnetic Compatibility

The drive, when installed in a suitable enclosure and exercised with a random accessing routine at maximum data rate, shall meet the worldwide EMC requirements listed below.

IBM will provide technical support to assist users in complying with the EMC requirements.

- United States Federal Communications Commission (FCC) Rules and Regulations (Class B), Part 15.
- European Economic Community (EEC) directive number 76/889 related to the control of radio frequency interference and the Verband Deutscher Elektrotechniker (VDE) requirements of Germany (GOP).

5.8.1 CE Mark

The product is certified for compliance to EC directive 89/336/EEC. CE marking for the certification appears on the drive.

5.8.2 C-Tick Mark

The product complies with the following Australian EMC standard.

- Limits and methods of measurement of radio disturbance characteristics of information technology equipment, AS/NZS 3548:1995 Class B.

5.9 Safety

5.9.1 Underwriters Lab(UL) Approval

DCXA-2xxxxx complies with UL 1950:1995+A1.

5.9.2 Canadian Standards Authority(CSA) Approval

DCXA-2xxxxx complies with CSA C22.2 950-M1995.

5.9.3 IEC Compliance

DCXA-2xxxxx complies with IEC 950:1991+A1-4.

5.9.4 German Safety Mark

DCXA-2xxxxx are approved by TUV on Test Requirement:

EN 60 950:1992+A1-4.

5.9.5 Flammability

Printed Circuit boards used in this product are made of material with a UL recognized flammability rating of V-1 or better. The flammability rating is marked or etched on the board. All other parts not considered electrical components are made of material with a UL recognized flammability rating of V-1 or better except minor mechanical parts.

5.9.6 Secondary Circuit Protection

This product utilizes printed circuit wiring that must be protected against the possibility of sustained combustion due to circuit or component failure. Adequate secondary over current protection is the responsibility of the using system.

User must protect the drive from it's electrical short circuit problem. 10 A limit is required for safety purpose.

5.10 Packaging

Drives will be shipped in appropriate containers and placed on pallets.

Drives are shipped in ESD protective bags.

6.0 Electrical Interface Specifications

6.1 Cabling

The maximum cable length from the host system to the drive plus circuit pattern length in the host system shall not exceed 18 inches.

6.2 Interface Connector

The signal connector for AT Attachment is designed to mate with Dupont part number 69764-044 or equivalent.

Figure 21 and Figure 19 show the connector location and physical pin location.

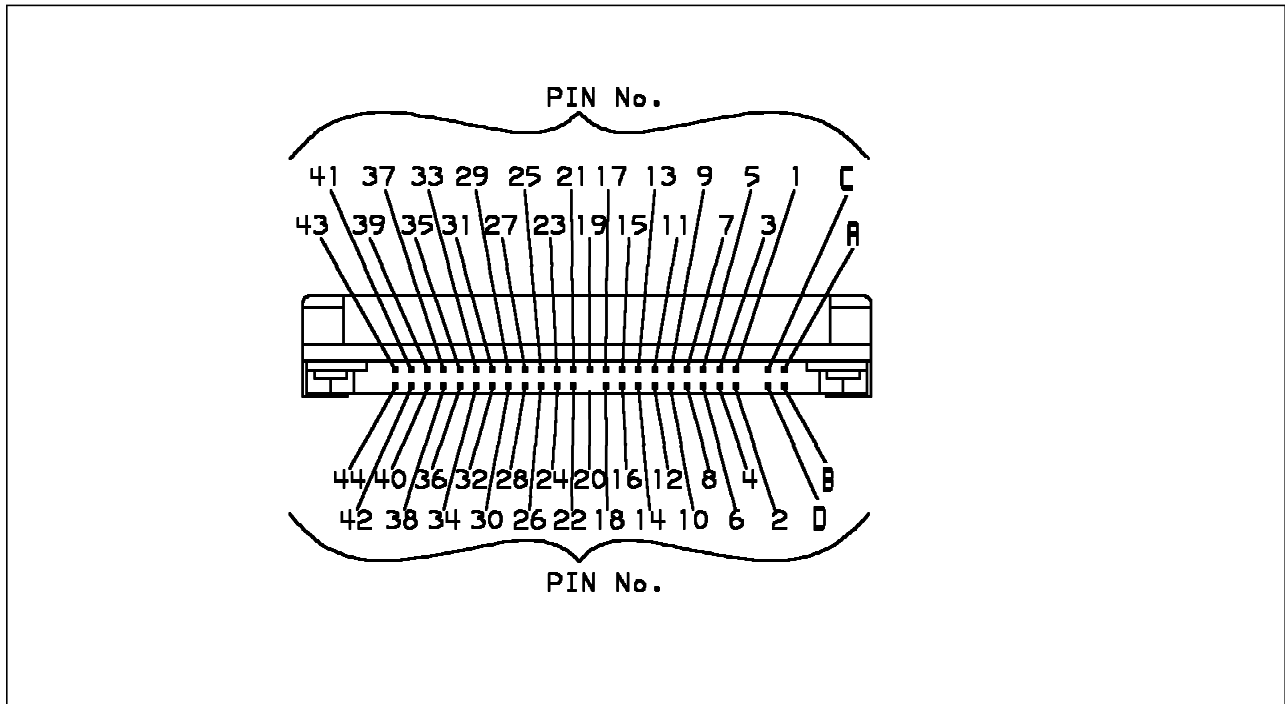

Figure 21. AT Attachment connector of DCXA-2xxxxx

Note 1 : Pin position 20 is left blank for correct connector insertion.

Note 2 : Pin position A,B,C,D are used for drive address setting. (Refer to Figure 36 on page 50 for address setting.)

6.2.1 Signal Definition

The pin assignments of interface signals are listed as follows:

PIN	SIGNAL	I/O	Type	PIN	SIGNAL	I/O	Type
01	-RESET	I	TTL	02	GND		
03	DD07	I/O	3-state	04	DD08	I/O	3-state
05	DD06	I/O	3-state	06	DD09	I/O	3-state
07	DD05	I/O	3-state	08	DD10	I/O	3-state
09	DD04	I/O	3-state	10	DD11	I/O	3-state
11	DD03	I/O	3-state	12	DD12	I/O	3-state
13	DD02	I/O	3-state	14	DD13	I/O	3-state
15	DD01	I/O	3-state	16	DD14	I/O	3-state
17	DD00	I/O	3-state	18	DD15	I/O	3-state
19	GND			(20)	Key		
21	DMARQ	0	3-state	22	GND		
23	-DIOW(*)	I	TTL	24	GND		
25	-DIOR(*)	I	TTL	26	GND		
27	IORDY(*)	0	OD	28	CSEL	I	TTL
29	-DMACK	I	TTL	30	GND		
31	INTRQ	0	3-state	32	-IOCS16	0	OD
33	DA01	I	TTL	34	-PDIAG	I/O	OD
35	DA00	I	TTL	36	DA02	I	TTL
37	-CS0	I	TTL	38	-CS1	I	TTL
39	-DASP	I/O	OD	40	GND		
41	+5V Logic	PWR		42	+5V MOTOR	PWR	
43	GND			44	(Resv)		

Figure 22. Table of signals

Notes:

1. "O" designates an output from the Drive.
2. "I" designates an input to the Drive.
3. "I/O" designates an input/output common.
4. "OD" designates Open-Drain output.
5. The signal lines marked with (*) are redefined during the Ultra DMA protocol to provide special functions. These lines change from the conventional to special definitions at the moment the Host decides to allow a DMA burst, if the Ultra DMA transfer mode was previously chosen via SetFeatures. The Drive becomes aware of this change upon assertion of the -DMACK line. These lines revert back to their original definitions upon the deassertion of -DMACK at the termination of the DMA burst.

	Special Definition (for Ultra DMA)	Conventional Definition
Write Operation	-DDMARDY HSTROBE STOP	IORDY -DIOR -DIOW
Read Operation	-HDMARDY DSTROBE STOP	-DIOR IORDY -DIOW

Figure 23. Signal Special Definitions for Ultra DMA

6. "PWR" designates a power supply to the drive.

7. "(Resv)" designates reserved pin which must be left unconnected.

- DD00-DD15** 16-bit bi-directional data bus between the host and the HDD. The lower 8 lines, DD00-07, are used for Register and ECC access. All 16 lines, DD00-15, are used for data transfer. These are 3-State lines with 24 mA current sink capability.
- DA00-DA02** Address used to select the individual register in the HDD.
- CS0** Chip select signal generated from the Host address bus. When active, one of the Command Block Registers (Data, Error{Features when written}, Sector Count, Sector Number, Cylinder Low, Cylinder High, Drive/Head and Status{Command when written} register) can be selected. (See Figure 37 on page 51.)
- CS1** Chip select signal generated from the Host address bus. When active, one of the Control Block Registers (Alternate Status{Device Control when written} and Drive Address register) can be selected. (See Figure 37 on page 51.)
- RESET** This line is used to reset the HDD. It shall be kept Low logic state during power up and kept High thereafter.
- DIOW** Its rising edge holds data from the host data bus to a register or data register of the HDD.
- DIOR** When low, this signal enables data from a register or data register of the drive onto data bus. The data on the bus shall be latched on the rising edge of -DIOR.
- INTRQ** Interrupt is enabled only when the drive is selected, and the host activates the -IEN bit in the Device Control Reg. Otherwise, this signal is in high impedance state regardless of the state of the IRQ bit. The interrupt is set when the IRQ bit is set by the drive CPU. IRQ is reset to zero by a host read of the status register or a write to the Command Reg. This signal is a 3-State line with 24 mA sink capability.
- IOCS16** Indication to the host that a 16-bit wide data register has been addressed and that the drive is prepared to send or receive a 16-bit wide data word. This signal is an Open-Drain output with 24 mA sink capability and an external resistor is needed to pull this line to 5 volts.
- DASP** This is a time-multiplexed signal which indicates that a drive is active, or that device 1 is present. This signal is driven by Open-Drain driver and internally pulled-up to 5 volts through a 10k Ω resistor.
During Power-On initialization or after -RESET is negated, -DASP shall be asserted by Device 1 within 400 msec to indicate that device 1 is present. Device 0 shall allow up to 450msec for device 1 to assert -DASP. If device 1 is not present, device 0 may assert -DASP to drive a LED indicator.
-DASP shall be negated following acceptance of the first valid command by device 1.
Anytime after negation of -DASP, either drive may assert -DASP to indicate that a drive is active.
- PDIAG** This signal shall be asserted by device 1 to indicate to device 0 that it has completed diagnostics. This line is pulled-up to 5 volts in the HDD through a 10k Ω resistor.
Following a Power On Reset, software reset or -RESET, drive 1 shall negate -PDIAG within 1 msec (to indicate to device 0 that it is busy). Drive 1 shall then assert -PDIAG within 30 seconds to indicate that it is no longer busy, and is able to provide status.
Following the receipt of a valid Execute Drive Diagnostics command, device 1 shall negate -PDIAG within 1 msec to indicate to device 0 that it is busy and has not yet passed its drive diagnostics. If device 1 is present then device 0 shall wait up to 6 seconds from the receipt of a valid Execute Drive Diagnostics command for drive 1 to assert -PDIAG. Device 1 should clear BSY before asserting -PDIAG, as -PDIAG is used to indicate that device 1 has passed its diagnostics and is ready to post status.
If -DASP was not asserted by device 1 during reset initialization, device 0 shall post its own status immediately after it completes diagnostics, and clear the device 1 Status register to

00h. Device 0 may be unable to accept commands until it has finished its reset procedure and is ready (DRDY=1).

CSEL (Cable Select)

This signal is monitored to determine the drive address, 0 or 1, when the jumper on the interface connector is at Position-3. (See Figure 36 on page 50.)

- When CSEL is ground or a low level, the drive works as address 0.
- When CSEL is open or a high level, the drive works as address 1.

The signal level of CSEL to one drive should be different from the signal level to another drive on the same AT interface cable to avoid drive address 0-0 or 1-1 configuration.

KEY

Pin position 20 has no connection pin. It is recommended to close the respective position of the cable connector in order to avoid incorrect insertion by mistake.

IORDY

Indication to host that the drive is ready to complete current I/O cycle. This line is driven low at the falling edge of -DIOR or -DIOW, when HDD needs some additional WAIT cycle(s) to extend PIO cycle. This line can be connected to host IORDY signal in order to insert WAIT state(s) in the host PIO cycle. This is an Open-Drain output with 24 mA sink capability.

5V Power

There are two input pins for +5V power supply, "+5V Logic" and "+5V Motor". "+5V Logic" is connected to the internal logic circuits and "+5V Motor" is connected to the spindle motor and motor driver. It is possible to turn on and off "+5V Logic" by an external switch circuit to reduce power consumption to the least possible. In this mode, a voltage drop out due to the motor spin up current can be reduced by connecting "+5V Motor" line into the system power source directly. If the host system while the HDD is disconnected from power line shall be isolated by Three-State line drivers. Internal leakage through ESD protection circuit may pull down LPUL (Least Positive Up Level) of logic signal below the spec. Use both lines in parallel, for regular HDD application. 5 volts.

-DMACK

This signal shall be used by the host in response to DMARQ to either acknowledge that data has been accepted, or that data is available.

This signal is internally pulled-up to 5Volt through 15 K ohm resistor and the tolerance of the resistor value is -50% to +100%.

DMARQ

This signal, used for DMA data transfers between host and drive, shall be asserted by the drive when it is ready to transfer data to or from the host. The direction of data transfer is controlled by -HIOR and -HIOW. This signal is used on a handshake manner with -DMACK. This signal is a 3-state line with 24mA sink capability and internally pulled-down to GND through 10 kΩ resistor.

-HDMARDY (Ultra DMA)

This signal is used only for Ultra DMA data transfers between host and drive.

-HDMARDY is a flow control signal for Ultra DMA data in bursts. This signal is held asserted by the host to indicate to the device that the host is ready to receive Ultra DMA data in transfers. The host may negate -HDMARDY to pause an Ultra DMA data in transfer.

HSTROBE (Ultra DMA)

This signal is used only for Ultra DMA data transfers between host and drive.

HSTROBE is the data out strobe signal from the host for an Ultra DMA data out transfer. Both the rising and falling edge of HSTROBE latch the data from DD(15:0) into the device. The host may stop toggling HSTROBE to pause an Ultra DMA data out transfer.

STOP (Ultra DMA)

This signal is used only for Ultra DMA data transfers between host and drive.

STOP shall be asserted by the host prior to initiation of an Ultra DMA burst. STOP shall be negated by the host before data is transferred in an Ultra DMA burst. Assertion of STOP by the host during or after data transfer in an Ultra DMA mode signals the termination of the burst.

-DDMARDY (Ultra DMA)

This signal is used only for Ultra DMA data transfers between host and drive.

-DDMARDY is a flow control signal for Ultra DMA data out bursts. This signal is held asserted by the device to indicate to the host that the device is ready to receive Ultra DMA data out transfers. The device may negate -DDMARDY to pause an Ultra DMA data out transfer.

DSTROBE (Ultra DMA)

This signal is used only for Ultra DMA data transfers between host and drive.

DSTROBE is the data in strobe signal from the device for an Ultra DMA data in transfer. Both the rising and falling edge of DSTROBE latch the data from DD(15:0) into the host. The device may stop toggling DSTROBE to pause an Ultra DMA data in transfer.

6.3 Interface Logic Signal Levels

The interface logic signals have the following electrical specifications:

Inputs :	Input High Voltage	–	2.0 V min./ Vcc+0.7 V max.
	Input Low Voltage	–	–0.5 V min./ 0.8 V max.
Outputs :	Output High Voltage	–	2.4 V min.
	Output Low Voltage	–	0.5 V max.
Current :	Driver Sink Current	–	24 mA min.
	Driver Source Current	–	–400 uA min.

6.4 Reset timings

HDD reset timing.

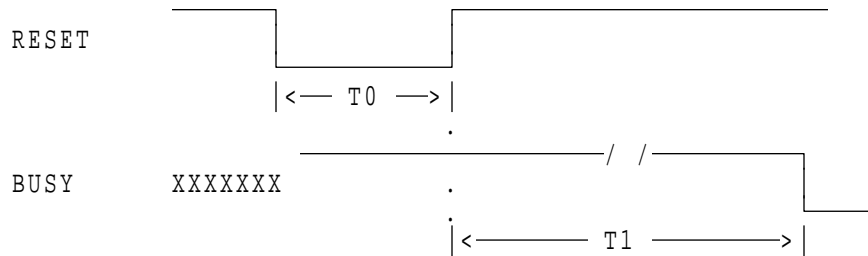

	PARAMETER DESCRIPTION	Min (usec)	Max (sec)
T0	RESET low width	25	—
T1	RESET high to Not BUSY	—	9.5

Figure 24. System Reset timing

6.5 PIO Timings

The PIO cycle timings meet Mode 4 of the ATA-3 description.

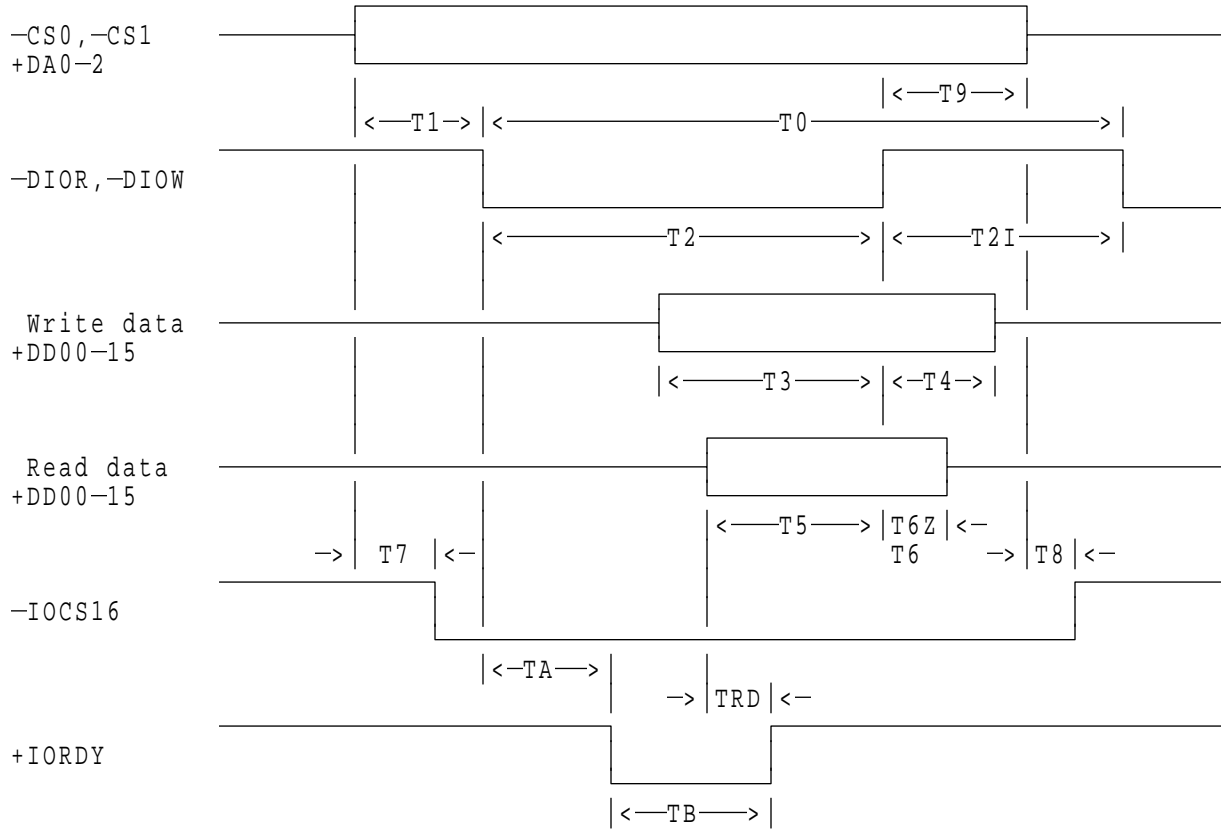

	PARAMETER DESCRIPTION	MIN (nsec)	MAX (nsec)	Note
T0	Cycle time	120	—	
T1	$\overline{\text{CS0-1}}, \text{+DA00-02}$ valid to $\overline{\text{DIOR}}, \overline{\text{DIOW}}$ active	25	—	
T2	$\overline{\text{DIOR}}, \overline{\text{DIOW}}$ pulse width	70	—	
T2I	$\overline{\text{DIOR}}, \overline{\text{DIOW}}$ recovery	25	—	
T3	+DD00-15 setup to $\overline{\text{DIOW}}$ high	20	—	
T4	$\overline{\text{DIOW}}$ high to +DD00-15 hold	10	—	
T5	+DD00-15 setup to $\overline{\text{DIOR}}$ high	20	—	*1
T6	$\overline{\text{DIOR}}$ high to +DD00-15 hold	5	—	
T6Z	$\overline{\text{DIOR}}$ high to +DD00-15 tristate	—	30	
T7	$\overline{\text{CS0-1}}, \text{+DA00-02}$ valid to $\overline{\text{IOCS16}}$ assertion	—	30	
T8	$\overline{\text{CS0-1}}, \text{+DA00-02}$ invalid to $\overline{\text{IOCS16}}$ negation	—	30	
T9	$\overline{\text{DIOR}}, \overline{\text{DIOW}}$ high to $\overline{\text{CS0-1}}, \text{+DA00-02}$ hold	10	—	
TRD	Read data valid to +IORDY active	0	—	
TA	$\overline{\text{DIOR}}, \overline{\text{DIOW}}$ low to +IORDY low	—	35	
TB	+IORDY pulse width	—	1250	

Note *1 : This value is applied only when +IORDY is not negated. When +IORDY is negated, TRD is applied.

Figure 25. PIO cycle timings

6.5.1 DMA Timings (Single Word)

The Single Word DMA timing meets Mode 2 of the ATA-3 description.

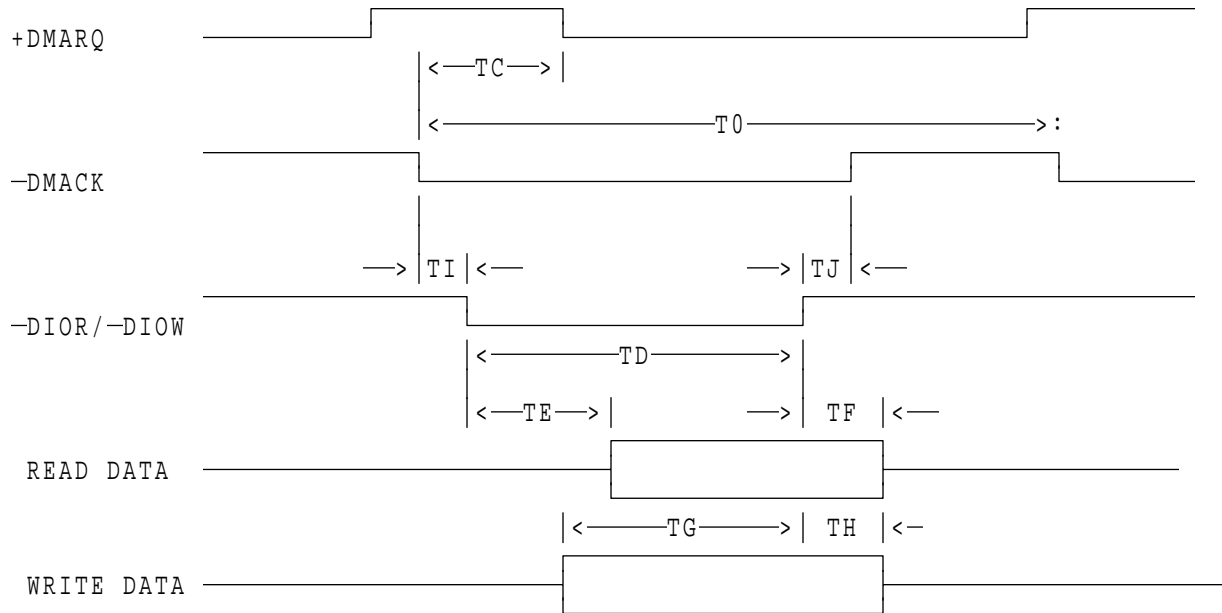

	PARAMETER DESCRIPTION	MIN (nsec)	MAX (nsec)	Note
T0	Cycle time	240	—	
TC	-DMACK active to +DMARQ inactive	—	80	
TD	-DIOR, -DIOW pulse width	120	—	
TE	-DIOR data access	—	60	
TF	-DIOR data hold	5	—	
TG	-DIOW data setup	35	—	
TH	-DIOW data hold	20	—	
TI	-DMACK to -DIOR/-DIOW setup	0	—	
TJ	-DIOR/-DIOW to -DMACK hold	0	—	

Figure 26. DMA (Single Word) cycle timings

6.5.2 DMA Timings (Multiword)

The Multiword DMA timing meets Mode 2 of the ATA-3 description.

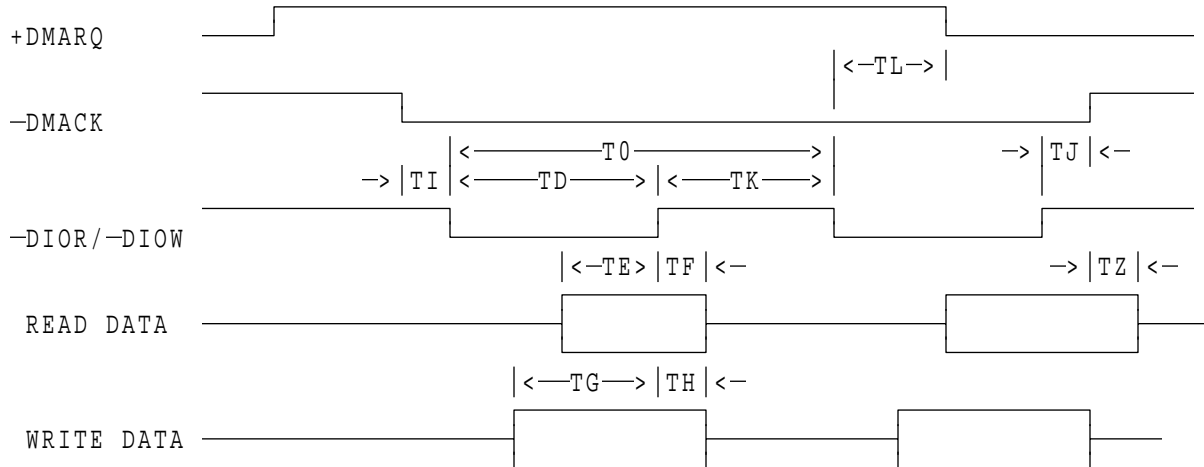

	PARAMETER DESCRIPTION	MIN (nsec)	MAX (nsec)	Note
T0	Cycle time	120	—	
TD	-DIOR,-DIOW pulse width	70	—	
TE	-DIOR data setup	20	—	
TF	-DIOR data hold	5	—	
TG	-DIOW data setup	20	—	
TH	-DIOW data hold	10	—	
TI	-DMACK to -DIOR/-DIOW setup	0	—	
TJ	-DIOR/-DIOW to -DMACK hold	5	—	
TK	-DIOR/-DIOW negated pulse width	25	—	
TL	-DIOR/-DIOW to -DMARQ delay	—	35	
TZ	-DMACK to tristate	—	25	

Figure 27. DMA (Multi Word) cycle timings

6.5.3 Ultra DMA Timings

The Ultra DMA timing meets Mode 0, 1 and 2 of the Ultra DMA/33 -- a Proposal for a New Protocol in ATA/ATAPI-4 (X3T13/D96153 Revision 1)

6.5.3.1 Initiating Read DMA

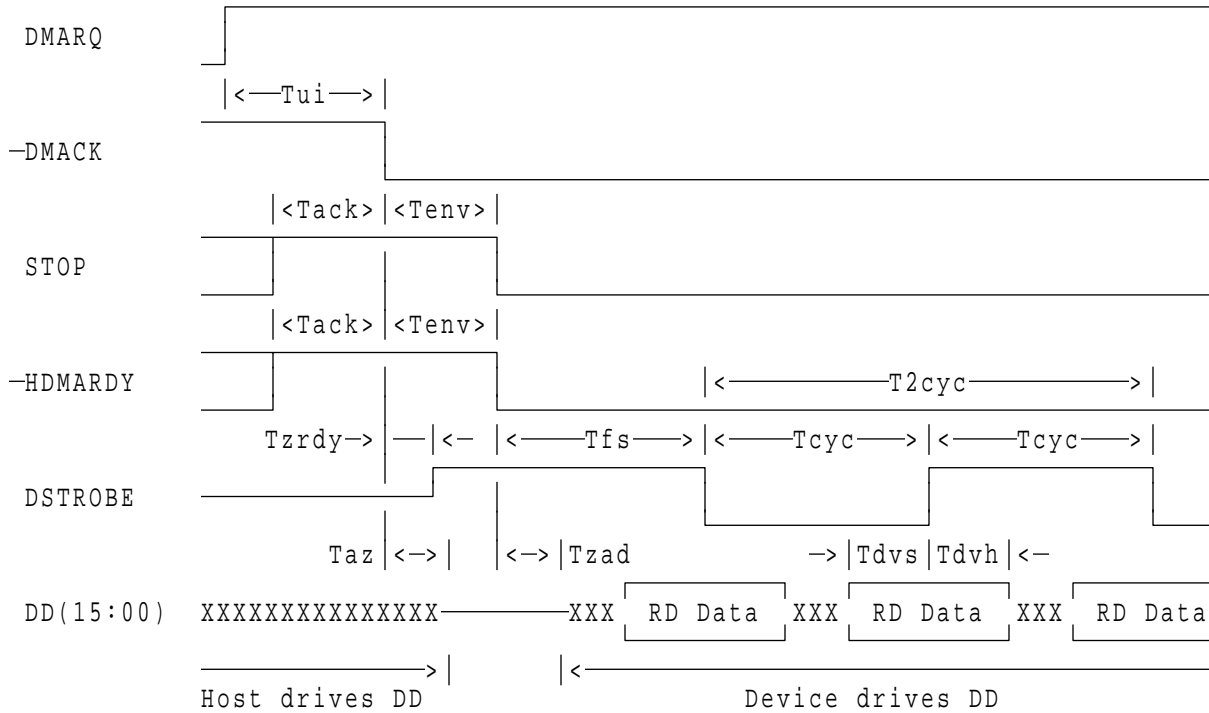

[nsec]

PARAMETER DESCRIPTION	MODE0		MODE1		MODE2	
	MIN	MAX	MIN	MAX	MIN	MAX
Tui	0	—	0	—	0	—
Tack	20	—	20	—	20	—
Tenv	20	70	20	70	20	70
Tzrdy	0	—	0	—	0	—
Tfs	0	230	0	200	0	170
Tcyc	114	—	75	—	55	—
T2cyc	235	—	156	—	117	—
Taz	—	10	—	10	—	10
Tzad	0	—	0	—	0	—
Tdvs	70	—	48	—	34	—
Tdvh	6	—	6	—	6	—

Figure 28. Ultra DMA cycle timings (Initiating Read)

6.5.3.2 Host Pausing Read DMA

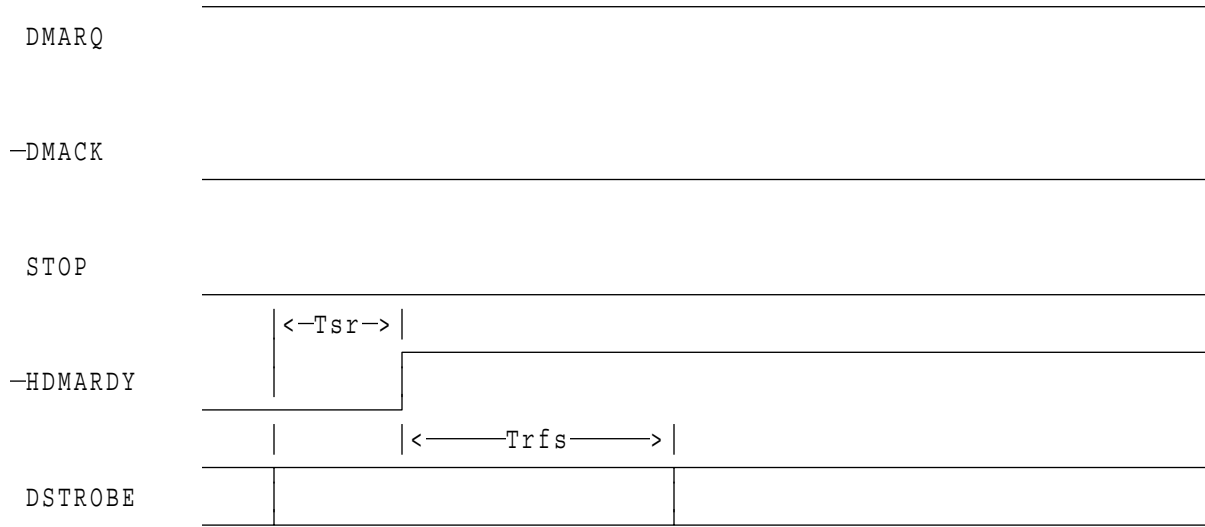

[nsec]

	PARAMETER DESCRIPTION	MODE0		MODE1		MODE2	
		MIN	MAX	MIN	MAX	MIN	MAX
Tsr	Strobe to ready response time	—	50	—	30	—	20
Trfs	Ready to final strobe time	—	75	—	60	—	50

Note : When a host does not meet Tsr, it should be ready to receive 2 more strobes after -HDMARDY is negated.

Figure 29. Ultra DMA cycle timings (Host pausing Read)

6.5.3.3 Host Terminating Read DMA

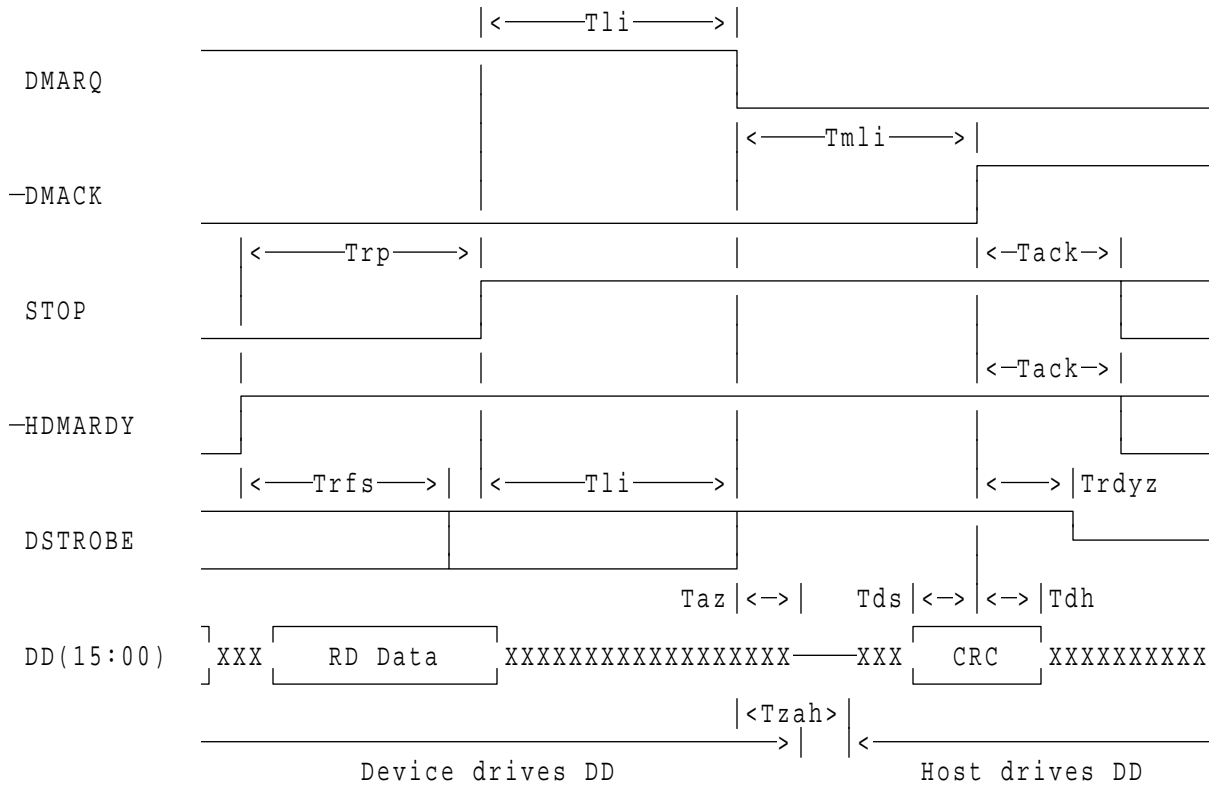

[nsec]

	PARAMETER DESCRIPTION	MODE0		MODE1		MODE2	
		MIN	MAX	MIN	MAX	MIN	MAX
Trfs	Ready to final strobe time	-	75	-	60	-	50
Trp	Ready to pause time	160	-	125	-	100	-
Tli	Limited interlock time	0	150	0	150	0	150
Taz	Output release time	-	10	-	10	-	10
Tzah	Output enable time	20	-	20	-	20	-
Tmli	Interlock time	20	-	20	-	20	-
Tds	Data setup time (at device side)	15	-	10	-	7	-
Tdh	Data Hold time (at device side)	5	-	5	-	5	-
Tack	Hold time after -DMACK negation	20	-	20	-	20	-
Trdyz	Pull-up time before DSTROBE release	-	20	-	20	-	20

Figure 30. Ultra DMA cycle timings (Host terminating Read)

6.5.3.4 Device Terminating Read DMA

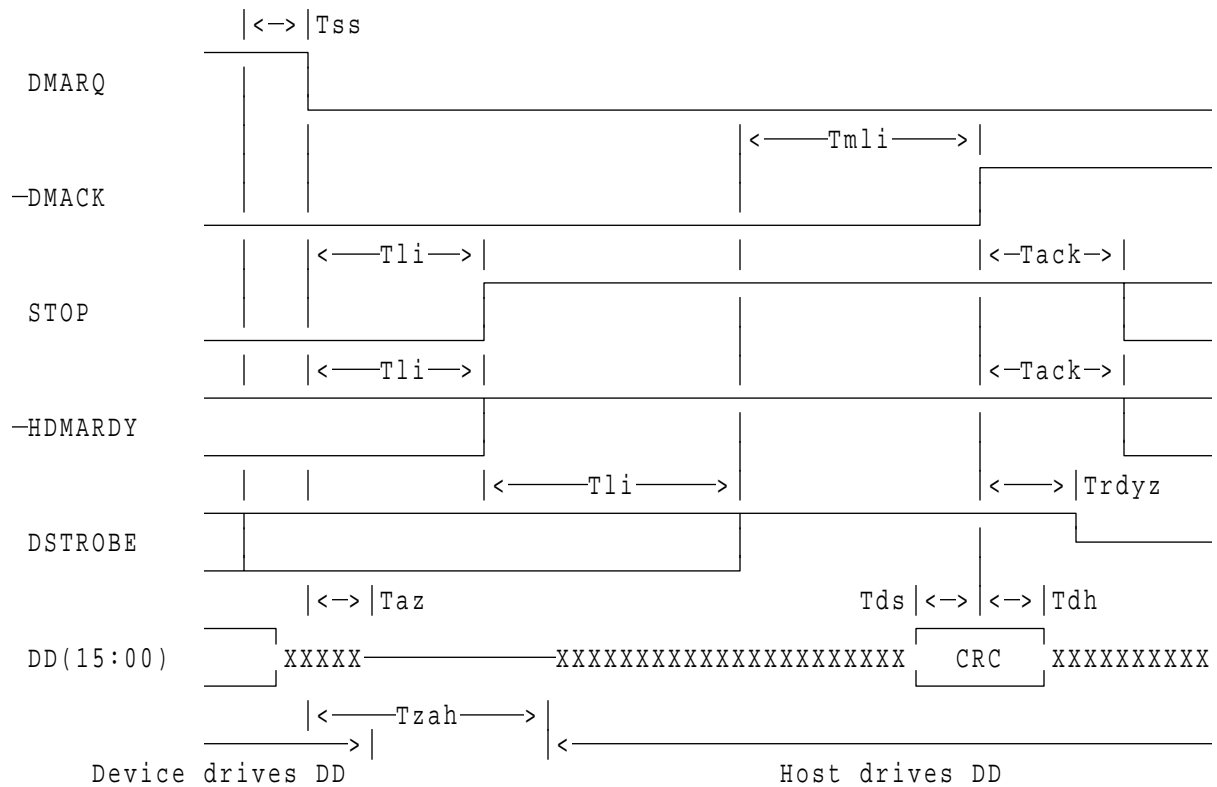

[nsec]

	PARAMETER DESCRIPTION	MODE0		MODE1		MODE2	
		MIN	MAX	MIN	MAX	MIN	MAX
Tss	Time from strobe to stop assertion	50	—	50	—	50	—
Tli	Limited interlock time	0	150	0	150	0	150
Taz	Output release time	—	10	—	10	—	10
Tzah	Output enable time	20	—	20	—	20	—
Tmli	Interlock time	20	—	20	—	20	—
Tds	Data setup time (at device side)	15	—	10	—	7	—
Tdh	Data Hold time (at device side)	5	—	5	—	5	—
Tack	Hold time after -DMACK negation	20	—	20	—	20	—
Trdyz	Pull-up time before DSTROBE release	—	20	—	20	—	20

Figure 31. Ultra DMA cycle timings (Device terminating Read)

6.5.3.5 Initiating Write DMA

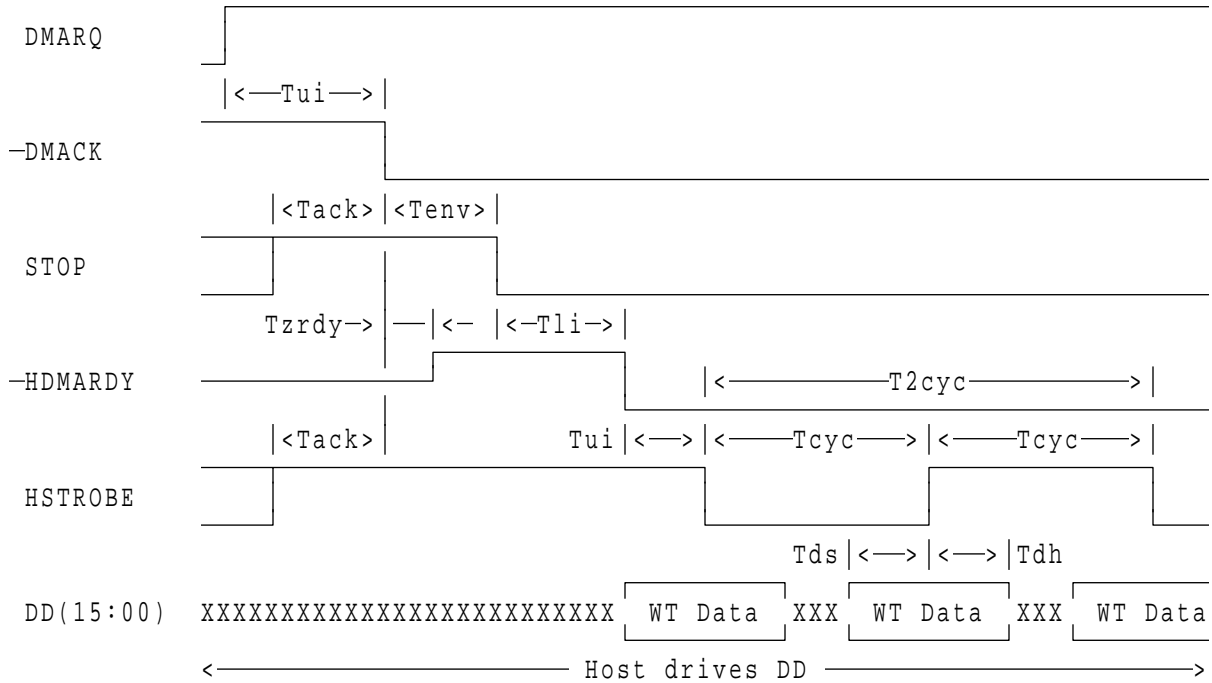

[nsec]

	PARAMETER DESCRIPTION	MODE0		MODE1		MODE2	
		MIN	MAX	MIN	MAX	MIN	MAX
Tui	Unlimited interlock time	0	—	0	—	0	—
Tack	Setup time before -DMACK assertion	20	—	20	—	20	—
Tenv	Envelope time	20	70	20	70	20	70
Tzrdy	Wait time before driving DDMARDY	0	—	0	—	0	—
Tli	Limited interlock time	0	150	0	150	0	150
Tcyc	Cycle Time	114	—	75	—	55	—
T2cyc	2 Cycle time	235	—	156	—	117	—
Tds	Data setup time (at device side)	15	—	10	—	7	—
Tdh	Data Hold time (at device side)	5	—	5	—	5	—

Figure 32. Ultra DMA cycle timings (Initiating Write)

6.5.3.6 Device Pausing Write DMA

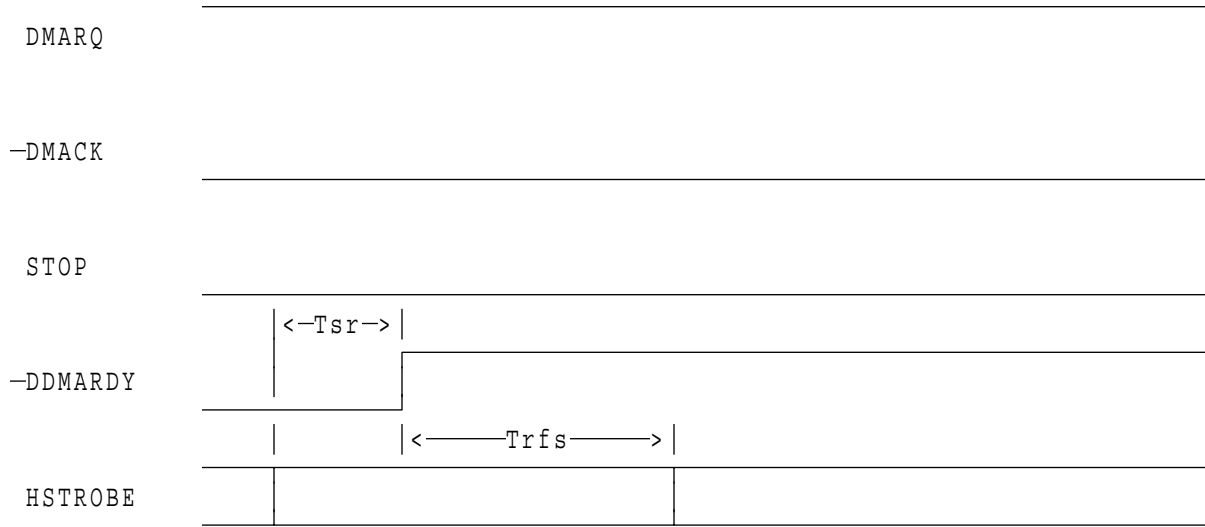

		[nsec]					
	PARAMETER DESCRIPTION	MODE0		MODE1		MODE2	
		MIN	MAX	MIN	MAX	MIN	MAX
Tsr	Strobe to ready response time	—	50	—	30	—	20
Trfs	Ready to final strobe time	—	75	—	60	—	50

Note : When a device does not meet Tsr, it shall be ready to receive 2 more strobes after -DDMARDY is negated.

Figure 33. Ultra DMA cycle timings (Device pausing Write)

6.5.3.7 Device Terminating Write DMA

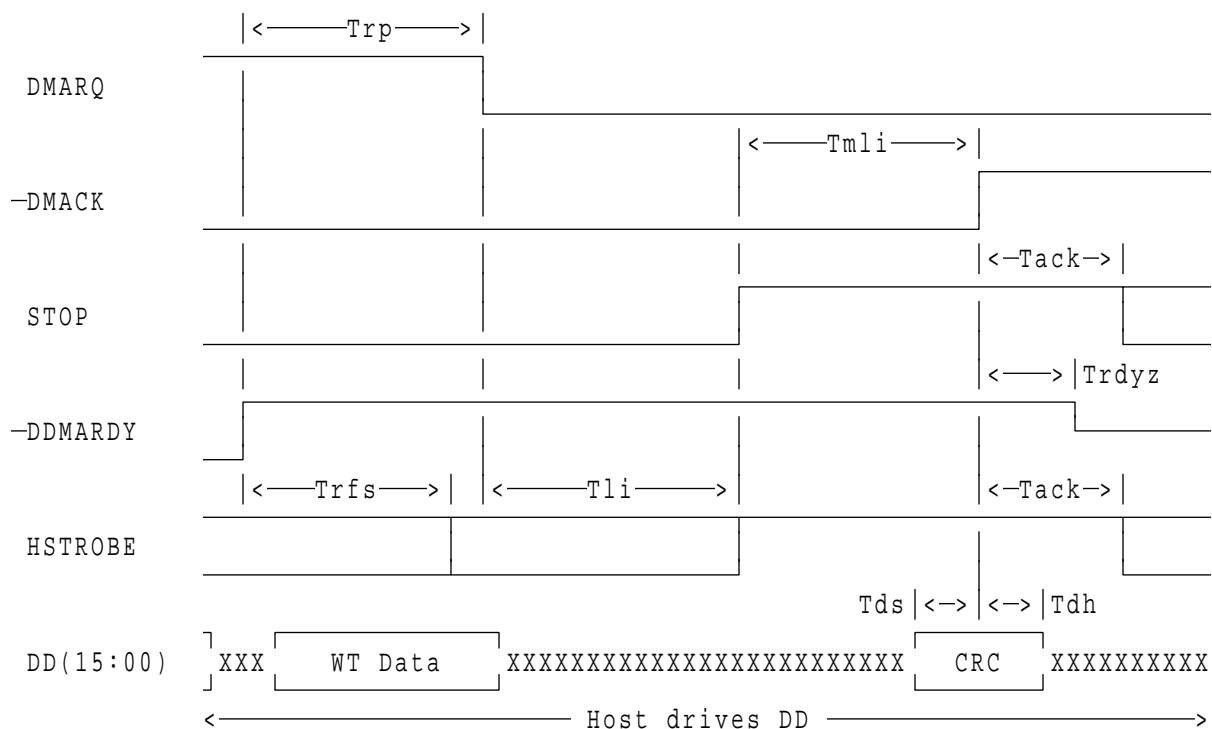

[nsec]

	PARAMETER DESCRIPTION	MODE0		MODE1		MODE2	
		MIN	MAX	MIN	MAX	MIN	MAX
Trfs	Ready to final strobe time	—	75	—	60	—	50
Trp	Ready to pause time	160	—	125	—	100	—
Tli	Limited interlock time	0	150	0	150	0	150
Tmli	Interlock time	20	—	20	—	20	—
Tds	Data setup time (at device side)	15	—	10	—	7	—
Tdh	Data Hold time (at device side)	5	—	5	—	5	—
Tack	Hold time after -DMACK negation	20	—	20	—	20	—
Trdys	Pull-up time before DDMARDY release	—	20	—	20	—	20

Figure 34. Ultra DMA cycle timings (Device terminating Write)

6.5.3.8 Host Terminating Write DMA

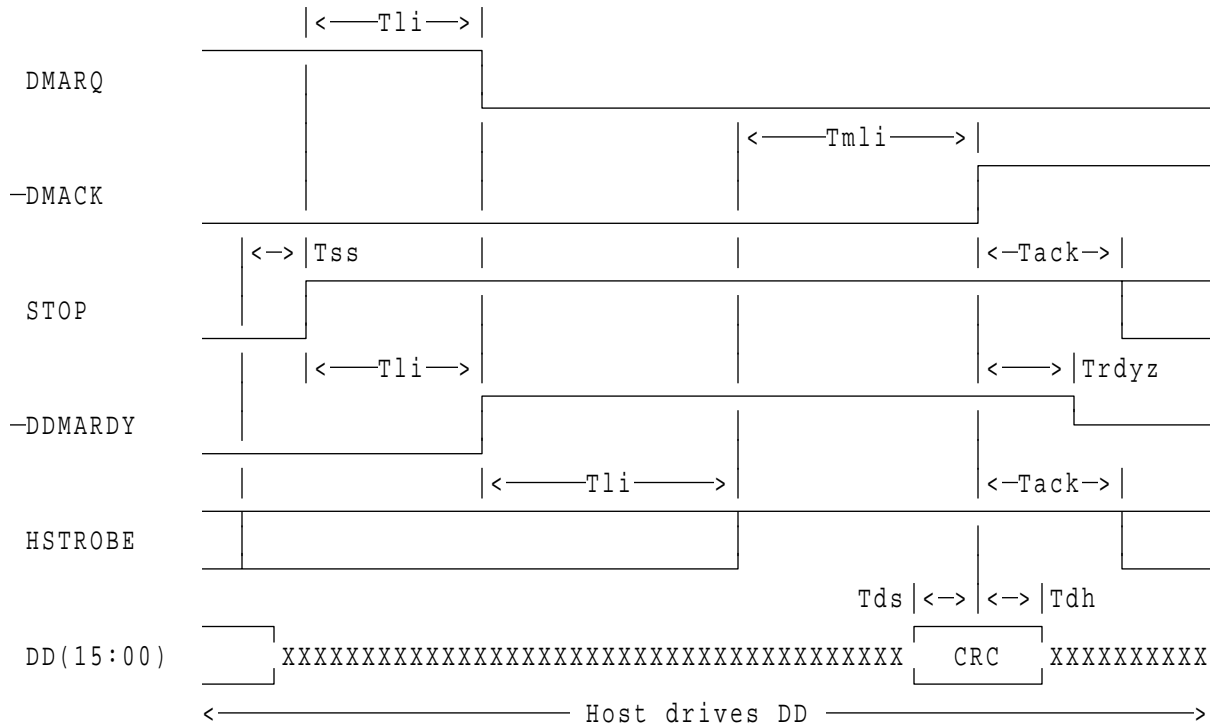

[nsec]

	PARAMETER DESCRIPTION	MODE0		MODE1		MODE2	
		MIN	MAX	MIN	MAX	MIN	MAX
Tss	Time from strobe to stop assertion	50	—	50	—	50	—
Tli	Limited interlock time	0	150	0	150	0	150
Tmli	Interlock time	20	—	20	—	20	—
Tds	Data setup time (at device side)	15	—	10	—	7	—
Tdh	Data Hold time (at device side)	5	—	5	—	5	—
Tack	Hold time after -DMACK negation	20	—	20	—	20	—
Trdyz	Pull-up time before DDMARDY release	—	20	—	20	—	20

Figure 35. Ultra DMA cycle timings (Host terminating Write)

6.6 Drive Address Setting

A jumper is available at the interface connector to determine the drive address. The set position of the jumper is as shown in Figure 36.

Using Cable Selection, the drive address depends on the condition of pin 28 of the AT interface cable. In the case when pin 28 is ground or low, the drive is a Master. If pin 28 is open or high level, the drive is a Slave.

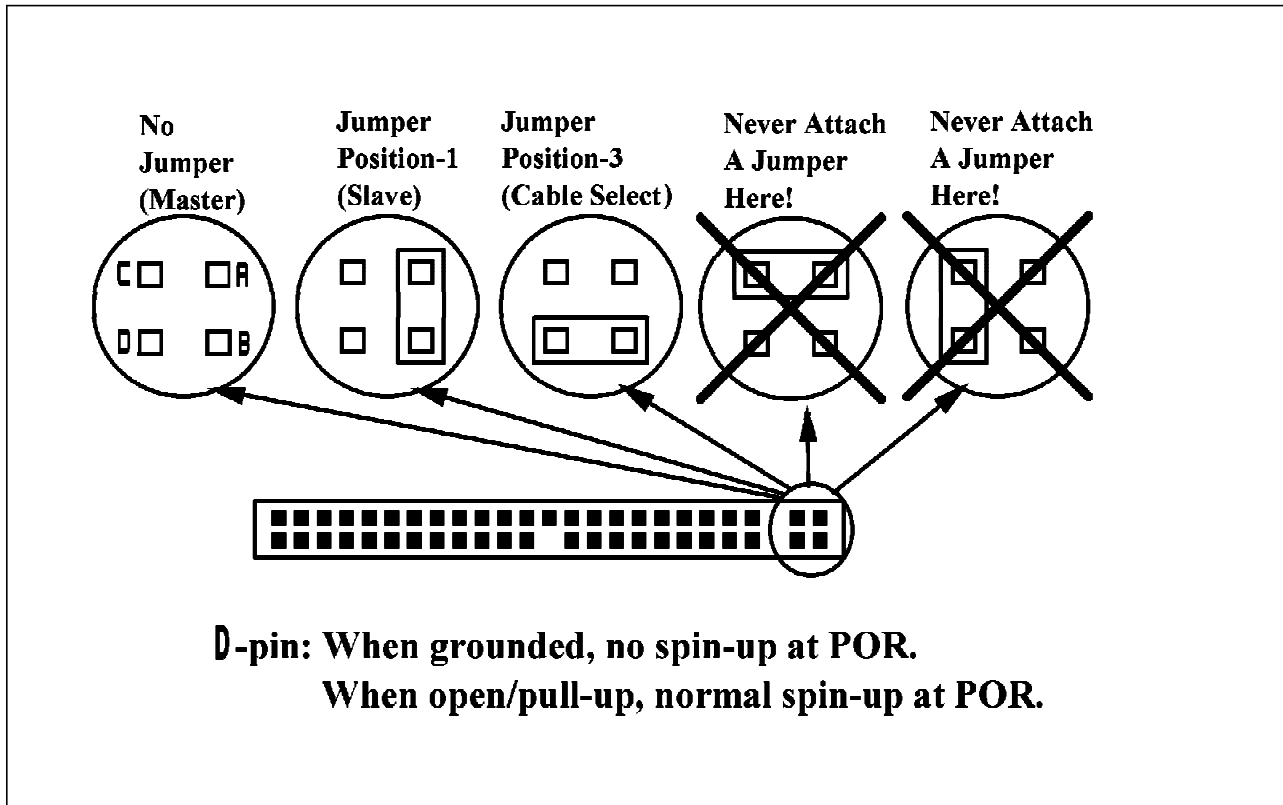

Figure 36. Address setting by a jumper for DCXA-2xxxxx.

6.6.1 Default Setting

The default setting of jumper at shipment is No Jumper (Master).

6.7 Addressing of drive Registers

The host addresses the drive through a set of registers called a Task File. These registers are mapped into the host's I/O space. Two chip select lines (-HCS0 and -HCS1) and three address lines (HA00-02) are used to select one of these registers, while a -HIOR or -HIOW is provided at the specified time.

The -HCS0 is used to address Command Block registers, while the -HCS1 is used to address Control Block registers.

The following table shows the standard I/O address range for IBM PC-AT machines.

Addr.	-CS0	-CS1	HA2	HA1	HA0	-HIOR = 0 (Read)	-HIOW = 0 (Write)
						Command Block Registers	
1F0	0	1	0	0	0	Data Reg.	Data Reg.
1F1	0	1	0	0	1	Error Reg.	Features Reg.
1F2	0	1	0	1	0	Sector count Reg.	Sector count Reg.
1F3	0	1	0	1	1	Sector number Reg.	Sector number Reg.
1F4	0	1	1	0	0	Cylinder low Reg.	Cylinder low Reg.
1F5	0	1	1	0	1	Cylinder high Reg.	Cylinder high Reg.
1F6	0	1	1	1	0	Drive/Head Reg.	Drive/Head Reg.
1F7	0	1	1	1	1	Status Reg.	Command Reg.
						Control Block Registers	
3F6	1	0	1	1	0	Alt. Status Reg.	Device control Reg
3F7	1	0	1	1	1	Drive address Reg.	—

Figure 37. Register Address

Note: "Addr." field is shown just as an example.

Part 2. ATA Interface Specification

7.0 General

7.1 Introduction

This specification describes the host interface of DCXA-2xxxxx.

The interface conforms to the Working Document of Information technology - AT Attachment with Packet Interface Extension (ATA/ATAPI-4) Revision 17 dated on October 30th, 1997 with certain limitations described in 8.0, "Deviations From Standard" on page 57.

DCXA-2xxxxx support following functions as Vendor Specific Function.

- Address Offset Feature
- Format Unit Function

7.2 Terminology

Device	Device indicates DCXA-2xxxxx.
Host	Host indicates the system that the device is attached to.
First Command	The command which is executed first right after power on reset or hard reset when the initial power mode at power on is Standby mode.
INTRQ	Interrupt request (Device or Host)

8.0 Deviations From Standard

The interface conforms to the Working Document of Information technology - AT Attachment with Packet Interface Extension (ATA/ATAPI-4) Revision 17 dated on October 30th, 1997 with deviation as follows.

- Write Verify** WRITE VERIFY command does not include read verification after write operation. The function is exactly same as WRITE SECTORS command.
- SMART Return Status** SMART RETURN STATUS subcommand does not check advisory attributes. That is, the device will not report threshold exceeded condition unless prefailure attributes exceed their corresponding thresholds. For example, Power-On Hours Attribute never results in negative reliability status.
- Standby Timer** Even if IDLE command or STANDBY command is issued with Sector Count register value 00h, Standby Timer is not disabled, but it sets default value 109 minutes. In case Sector Count register value is other than 00h, Standby Timer is set to (Sector Count register value) x 5 seconds.
- Check Power Mode** While the drive is in idle mode, FFh is returned as a response to Check Power Mode command. 80h is not used for the response.

9.0 Registers

Addresses					Functions	
CS0-	CS1-	DA2	DA1	DA0	READ(DIOR-)	WRITE(DIOW-)
N	N	x	x	x	Data bus high imped*1	Not used
					Control block registers	
N	A	0	x	x	Data bus high imped	Not used
N	A	1	0	x	Data bus high imped	Not used
N	A	1	1	0	Alternate Status	Device Control
N	A	1	1	1	Device Address	Not used
					Command block registers	
A	N	0	0	0	Data	Data
A	N	0	0	1	Error Register	Features
A	N	0	1	0	Sector Count	Sector Count
A	N	0	1	1	Sector Number	Sector Number
A	N	0	1	1	*2 LBA bits 0-7	*2 LBA bits 0-7
A	N	1	0	0	Cylinder Low	Cylinder Low
A	N	1	0	0	*2 LBA bits 8-15	*2 LBA bits 8-15
A	N	1	0	1	Cylinder High	Cylinder High
A	N	1	0	1	*2 LBA bits 16-23	*2 LBA bits 16-23
A	N	1	1	0	Device/Head	Device/Head
A	N	1	1	0	*2 LBA bits 24-27	*2 LBA bits 24-27
A	N	1	1	1	Status	Command
A	A	x	x	x	Invalid address	Invalid address

*1 "imped" stands for "impedance".
 *2 Mapping of registers in LBA mode

Logic conventions : A = signal asserted
 N = signal negated
 x = does not matter which it is

Figure 38. Register Set

Communication to or from the device is through an I/O Register that routes the input or output data to or from registers addressed by the signals from the host (CS0-, CS1-, DA2, DA1, DA0, DIOR- and DIOW-).

The Command Block Registers are used for sending commands to the device or posting status from the device.

The Control Block Registers are used for device control and to post alternate status.

9.1 Alternate Status Register

Alternate Status Register							
7	6	5	4	3	2	1	0
BSY	RDY	DF	DSC	DRQ	COR	IDX	ERR

Figure 39. Alternate Status Register

This register contains the same information as the Status Register. The only difference is that reading this register does not imply interrupt acknowledge or clear a pending interrupt. See 9.13, “Status Register” on page 63 for the definition of the bits in this register.

9.2 Command Register

This register contains the command code being sent to the device. Command execution begins immediately after this register is written. The command set is shown in Figure 56 on page 95.

All other registers required for the command must be set up before writing the Command Register.

9.3 Cylinder High Register

This register contains the high order bits of the starting cylinder address for any disk access. At the end of the command, this register is updated to reflect the current cylinder number.

In LBA Mode this register contains Bits 16-23. At the end of the command, this register is updated to reflect the current LBA Bits 16-23.

The cylinder number may be from zero to the number of cylinders minus one.

9.4 Cylinder Low Register

This register contains the low order 8 bits of the starting cylinder address for any disk access. At the end of the command, this register is updated to reflect the current cylinder number.

In LBA Mode this register contains Bits 8-15. At the end of the command, this register is updated to reflect the current LBA Bits 8-15.

The cylinder number may be from zero to the number of cylinders minus one.

9.5 Data Register

This register is used to transfer data blocks between the device data buffer and the host. It is also the register through which sector information is transferred on a Format Track command, and configuration information is transferred on an Identify Device command.

All data transfers are 16 bits wide, except for ECC byte transfers, which are 8 bits wide. Data transfers are PIO only.

The register contains valid data only when DRQ=1 in the Status Register.

9.6 Device Control Register

Device Control Register							
7	6	5	4	3	2	1	0
—	—	—	—	1	SRST	-IEN	0

Figure 40. Device Control Register

Bit Definitions

- SRST (RST)** Software Reset. The device is held reset when RST=1. Setting RST=0 re-enables the device.
- The host must set RST=1 and wait for at least 5 microseconds before setting RST=0, to ensure that the device recognizes the reset.
- IEN** Interrupt Enable. When IEN=0, and the device is selected, device interrupts to the host will be enabled. When IEN=1, or the device is not selected, device interrupts to the host will be disabled.

9.7 Drive Address Register

Drive Address Register							
7	6	5	4	3	2	1	0
HIZ	-WTG	-H3	-H2	-H1	-H0	-DS1	-DS0

Figure 41. Drive Address Register

This register contains the inverted drive select and head select addresses of the currently selected drive.

Bit Definitions

- HIZ** High Impedance. This bit is not device and will always be in a high impedance state.
- WTG** -Write Gate. This bit is 0 when writing to the disk device is in progress.
- H3,-H2,-H1,-H0** -Head Select. These four bits are the one's complement of the binary coded address of the currently selected head. -H0 is the least significant.

- DS1** -Drive Select 1. Drive select bit for device 1, active low. DS1=0 when device 1 (slave) is selected and active.
- DS0** -Drive Select 0. Drive select bit for device 0, active low. DS0=0 when device 0 (master) is selected and active.

9.8 Device/Head Register

Device/Head Register							
7	6	5	4	3	2	1	0
1	L	1	DRV	HS3	HS2	HS1	HS0

Figure 42. Device/Head Register

This register contains the device and head numbers.

Bit Definitions

- L** Binary encoded address mode select. When L=0, addressing is by CHS mode. When L=1, addressing is by LBA mode.
- DRV** Device. When DRV=0, device 0 (master) is selected. When DRV=1, device 1 (slave) is selected.
- HS3,HS2,HS1,HS0** Head Select. These four bits indicate binary encoded address of the head . HS0 is the least significant bit. At command completion, these bits are updated to reflect the currently selected head.

The head number may be from zero to the number of heads minus one.

In LBA mode, HS3 through HS0 contain bits 24-27 of the LBA. At command completion, these bits are updated to reflect the current LBA bits 24-27.

9.9 Error Register

Error Register							
7	6	5	4	3	2	1	0
CRC	UNC	0	IDNF	0	ABRT	TK0NF	AMNF

Figure 43. Error Register

This register contains status from the last command executed by the device, or a diagnostic code.

At the completion of any command except Execute Device Diagnostic, the contents of this register are valid always even if ERR=0 in the Status Register.

Following a power on, a reset, or completion of an Execute Device Diagnostic command, this register contains a diagnostic code. See Figure 47 on page 67 for the definition.

Bit Definitions

ICRCE (CRC)	Interface CRC Error. CRC=1 indicates a CRC error has occurred on the data bus during a Ultra-DMA transfer.
UNC	Uncorrectable Data Error. UNC=1 indicates an uncorrectable data error has been encountered.
IDNF (IDN)	ID Not Found. IDN=1 indicates the requested sector's ID field could not be found.
ABRT (ABT)	Aborted Command. ABT=1 indicates the requested command has been aborted due to a device status error or an invalid parameter in an output register.
TK0NF (T0N)	Track 0 Not Found. T0N=1 indicates track 0 was not found during a Recalibrate command.
AMNF (AMN)	Address Mark Not Found. AMN=1 indicates the data address mark has not been found after finding the correct ID field for the requested sector.

9.10 Features Register

This register is command specific. This is used with the Set Features command, S.M.A.R.T. Function Set command and Format Unit command.

9.11 Sector Count Register

This register contains the number of sectors of data requested to be transferred on a read or write operation between the host and the device. If the value in the register is set to 0, a count of 256 sectors is specified.

If the register is zero at command completion, the command was successful. If not successfully completed, the register contains the number of sectors which need to be transferred in order to complete the request.

The contents of the register are defined otherwise on some commands. These definitions are given in the command descriptions.

9.12 Sector Number Register

This register contains the starting sector number for any disk data access for the subsequent command. The sector number is from one to the maximum number of sectors per track.

In LBA mode, this register contains Bits 0-7. At the end of the command, this register is updated to reflect the current LBA Bits 0-7.

9.13 Status Register

Status Register							
7	6	5	4	3	2	1	0
BSY	DRDY	DF	DSC	DRQ	CORR	IDX	ERR

Figure 44. Status Register

This register contains the device status. The contents of this register are updated whenever an error occurs and at the completion of each command.

If the host reads this register when an interrupt is pending, it is considered to be the interrupt acknowledge. Any pending interrupt is cleared whenever this register is read.

If BSY=1, no other bits in the register are valid.

Bit Definitions

BSY	Busy. BSY=1 whenever the device is accessing the registers. The host should not read or write any registers when BSY=1. If the host reads any register when BSY=1, the contents of the Status Register will be returned.
DRDY (RDY)	Device Ready. RDY=1 indicates that the device is capable of responding to a command. RDY will be set to 0 during power on until the device is ready to accept a command.
DF	Device Fault. DF=1 indicates that the device has detected a write fault condition. DF is set to 0 after the Status Register is read by the host.
DSC	Device Seek Complete. DSC=1 indicates that a seek has completed and the device head is settled over a track. DSC is set to 0 by the device just before a seek begins. When an error occurs, this bit is not changed until the Status Register is read by the host, at which time the bit again indicates the current seek complete status. When the device enters into or is in Standby mode or Sleep mode, this bit is set by device in spite of not spinning up.
DRQ	Data Request. DRQ=1 indicates that the device is ready to transfer a word or byte of data between the host and the device. The host should not write the Command register when DRQ=1.
CORR (COR)	Corrected Data. Always 0.
IDX	Index. IDX=1 once per revolution. Since IDX=1 only for a very short time during each revolution, the host may not see it set to 1 even if the host is reading the Status Register continuously. Therefore the host should not attempt to use IDX for timing purposes.
ERR	Error. ERR=1 indicates that an error occurred during execution of the previous command. The Error Register should be read to determine the error type. The device sets ERR=0 when the next command is received from the host.

10.0 General Operation Descriptions

10.1 Reset Response

There are three types of reset in ATA as follows:

Power On Reset (POR)

The device executes a series of electrical circuitry diagnostics, spins up the HDA, tests speed and other mechanical parametric, and sets default values.

Hard Reset (Hardware Reset)

RESET- signal is negated in ATA Bus.

The device executes a series of electrical circuitry diagnostics, spins up the HDA, tests speed and other mechanical parametric, and sets default values.

Soft Reset (Software Reset)

SRST bit in the Device Control Register is set, then is reset.

The device resets the interface circuitry according to the Set Features requirement.

The actions of each reset is shown in Figure 45 on page 66.

	POR	hard reset	soft reset
Aborting Host interface	—	0	0
Aborting Device operation	—	(*1)	(*1)
Initialization of hardware	0	0	x
Internal diagnostic	0	0	x
Spinning spindle	(*6)	x	x
Initialization of registers (*2)	0	0	0
DASP handshake	0	0	x
PDIAG handshake	0	0	0
Reverting programmed parameters to default	0	0	(*3)
— Number of CHS (set by Initialize Device Parameter)			
— Multiple mode			
— Write cache			
— Read look-ahead			
— ECC bytes			
— Volatile max address			
— Address offset mode			
Disable Standby timer	0	0	x
Power mode	(*6)	(*4)	(*4)
Reset Standby timer value (*5)	0	0	x

0 — execute
x — not execute

Figure 45. Reset Response Table

Note.

- (*1) Execute after the data in write cache has been written.
- (*2) Default value on POR is shown in Figure 46 on page 67.
- (*3) The Set Features command with Feature register = CCh enables the device to revert these parameters to the power on defaults.
- (*4) In the case of sleep mode, the device goes to idle mode. In other case, the device does not change current mode.
- (*5) After reset the Standby timer value, it is set to 109 minutes.
- (*6) According to the initial power mode selection.

10.1.1 Register Initialization

Register	Default Value
Error	Diagnostic Code
Sector Count	01h
Sector Number	01h
Cylinder Low	00h
Cylinder High	00h
Device/Head	A0h
Status	50h
Alternate Status	50h

Figure 46. Default Register Values

After power on, hard reset, or software reset, the register values are initialized as shown in Figure 46.

Code	Description
01h	No error detected
02h	Formatter device error
03h	Sector buffer error
04h	ECC circuitry error
05h	Controller microprocessor error
8xh	Device 1 failed

Figure 47. Diagnostic Codes

The meaning of the Error Register diagnostic codes resulting from power on, hard reset or the Execute Device Diagnostic command are shown in Figure 47.

10.2 Diagnostic and Reset considerations

For each Reset and Execute Device Diagnostic, the diagnostic is done as follows:

Power On Reset, Hard Reset

DASP- is read by Device 0 to determine if Device 1 is present. If Device 1 is present Device 0 shall read PDIAG- to determine when it is valid to clear the BSY bit and whether Device 1 has powered on or reset without error, otherwise Device 0 clears the BSY bit whenever it is ready to accept commands. Device 0 may assert DASP- to indicate device activity. If Device 1 is not present, Device 0 does not Assert DASP- at POR.

Soft Reset

If Device 1 is present Device 0 shall read PDIAG- to determine when it is valid to clear the BSY bit and whether Device 1 has reset without any errors, otherwise Device 0 shall simply reset and clear the BSY bit. DASP- is asserted by Device 0 (and Device 1 if it is present) in order to indicate device active.

Execute Device Diagnostic

If Device 1 is present, Device 0 shall read PDIAG- to determine when it is valid to clear the BSY bit and if Device 1 passed or failed the EXECUTE DEVICE DIAGNOSTIC command, otherwise Device 0 shall simply execute its diagnostics and then clear the BSY bit. DASP- is asserted by Device 0 (and Device 1 if it is present) in order to indicate the device is active.

In all the above cases: Power on, RESET-, Soft reset, and the EXECUTE DEVICE DIAGNOSTIC command the Device 0 Error register is shown in Figure 48.

Device 1 Present?	PDIAG- Asserted?	Device 0 Passed	Error Register
Yes	Yes	Yes	01h
Yes	Yes	No	0xh
Yes	No	Yes	81h
Yes	No	No	8xh
No	(not read)	Yes	01h
No	(not read)	No	0xh

Where x indicates the appropriate Diagnostic Code for the Power on, RESET-, Soft reset, or Device Diagnostic error.

Figure 48. Reset error register values

10.3 Sector Addressing Mode

All addressing of data sectors recorded on the device's media is by a logical sector address. The logical CHS address for DCXA-2xxxxx is different from the actual physical CHS location of the data sector on the disk media.

DCXA-2xxxxx support both Logical CHS Addressing Mode and LBA Addressing Mode as the sector addressing mode.

The host system may select either the currently selected CHS translation addressing or LBA addressing on a command-by-command basis by using the L bit in the DEVICE/HEAD register. So a host system must set the L bit to 1 if the host uses LBA Addressing mode.

10.3.1 Logical CHS Addressing Mode

The logical CHS addressing is made up of three fields: the cylinder number, the head number and the sector number. Sectors are numbered from 1 to the maximum value allowed by the current CHS translation mode but can not exceed 255(0FFh). Heads are numbered from 0 to the maximum value allowed by the current CHS translation mode but can not exceed 15(0Fh). Cylinders are numbered from 0 to the maximum value allowed by the current CHS translation mode but cannot exceed 65535(0FFFFh).

When the host selects a CHS translation mode using the INITIALIZE DEVICE PARAMETERS command, the host requests the number of sectors per logical track and the number of heads per logical cylinder. The device then computes the number of logical cylinders available in requested mode.

The default CHS translation mode is described in the Identify Device Information. The current CHS translation mode also is described in the Identify Device Information.

10.3.2 LBA Addressing Mode

Logical sectors on the device shall be linearly mapped with the first LBA addressed sector (sector 0) being the same sector as the first logical CHS addressed sector (cylinder 0, head 0, sector 1). Irrespective of the logical CHS translation mode currently in effect, the LBA address of a given logical sector does not change. The following is always true:

$$\text{LBA} = ((\text{cylinder} * \text{heads_per_cylinder} + \text{heads}) * \text{sectors_per_track}) + \text{sector} - 1$$

where heads_per_cylinder and sectors_per_track are the current translation mode values.

On LBA addressing mode, the LBA value is set to the following register.

Device/Head	<---	LBA bits 27-24
Cylinder High	<---	LBA bits 23-16
Cylinder Low	<---	LBA bits 15- 8
Sector Number	<---	LBA bits 7- 0

10.4 Power Management Feature

The power management feature set permits a host to modify the behavior in a manner which reduces the power required to operate. The power management feature set provides a set of commands and a timer that enables a device to implement low power consumption modes.

DCXA-2xxxxx implement the following set of functions.

1. A Standby timer
2. Idle command
3. Idle Immediate command
4. Sleep command
5. Standby command
6. Standby Immediate command

10.4.1 Power Mode

Sleep Mode The lowest power consumption when the device is powered on occurs in Sleep Mode. When in sleep mode, the device requires a reset to be activated. The time to respond could be as long as the power on reset time.

Standby Mode The device interface is capable of accepting commands, but as the media may not immediately accessible, there is a delay while waiting for the spindle to reach operating speed.

Idle Mode Refer to the section of Adoptive Battery Life Extender Feature.

Active Mode The device is in execution of a command or accessing the disk media with read look-ahead function or write cache function.

10.4.2 Power Management Commands

The Check Power Mode command allows a host to determine if a device is currently in, going to or leaving standby mode.

The Idle and Idle Immediate commands move a device to idle mode immediately from the active or standby modes. The idle command also sets the standby timer count and starts the standby timer.

The sleep command moves a device to sleep mode. The device's interface becomes inactive at the completion of the sleep command. A reset is required to move a device out of sleep mode. When a device exits sleep mode it will enter idle mode.

The Standby and Standby Immediate commands move a device to standby mode immediately from the active or idle modes. The standby command also sets the standby timer count.

10.4.3 Standby/Sleep command completion timing

1. Confirm the completion of writing cached data in the buffer to media
2. Unload heads on the ramp
3. Set DRDY bit and DSC bit in Status Register
4. Set INTRQ (completion of the command)

5. Activate the spindle break to stop the spindle motor
6. Wait until spindle motor is stopped
7. Perform post process

10.4.4 Standby timer

The standby timer provides a method for the device to automatically enter standby mode from either active or idle mode following a host programmed period of inactivity. If the device is in the active or idle mode, the device waits for the specified time period and if no command is received, the device automatically enters the standby mode.

If the value of SECTOR COUNT register on Idle command or Standby command is set to 00h, the device will automatically set the standby timer to 109 minutes.

10.4.5 Status

In the active, idle and standby modes, the device shall have RDY bit of the status register set. If BSY bit is not set, device shall be ready to accept any command.

In sleep mode, the device's interface is not active. A host shall not attempt to read the device's status or issue commands to the device.

10.4.6 Interface Capability for Power Modes

Each power mode affects the physical interface as defined in the following table:

Mode	BSY	RDY	Interface active	Media
Active	x	x	Yes	Active
Idle	o	1	Yes	Active
Standby	o	1	Yes	Inactive
Sleep	x	x	No	Inactive

Figure 49. Power conditions

Ready(RDY) is not a power condition. A device may post ready at the interface even though the media may not be accessible.

Though the interface is inactive in sleep mode, the access to the interface registers and the validity of INTRQ is guaranteed for two seconds after Sleep command is completed. After this period, the contents of interface registers may be lost. Since the contents of interface registers may be invalid, host should NOT check Status register nor Alternate Status register prior to issuing soft reset to wake up a device.

10.4.7 Initial Power Mode at Power On

After power on or hard reset the device goes to IDLE mode or STANDBY mode depending on the option. Refer to 6.6, " Drive Address Setting" on page 50 for the initial power mode selection.

10.5 Advanced Power Management Feature (ABLE-3)

This feature provides power saving without performance degradation. The Adaptive Battery Life Extender 3 (ABLE-3) technology intelligently manages transition among power modes within the device by monitoring access patterns of the host.

This technology has three idle modes; Performance Idle mode, Active Idle mode, and Low Power Idle mode.

This feature allows the host to select an advanced power management level. The advanced power management level is a scale from the lowest power consumption setting of 01h to the maximum performance level of FEh. Device performance may increase with increasing advanced power management levels. Device power consumption may increase with increasing advanced power management levels. The advanced power management levels contain discrete bands, described in the section of Set Feature command in detail.

This feature set uses the following functions:

- A SET FEATURES subcommand to enable Advanced Power Management
- A SET FEATURES subcommand to disable Advanced Power Management

The Advanced Power Management feature is independent of the Standby timer setting. If both Advanced Power Management level and the Standby timer are set, the device will go to the Standby state when the timer times out or the device's Advanced Power Management algorithm indicates that it is time to enter the Standby state.

The IDENTIFY DEVICE response word 83, bit 3 indicates that Advanced Power Management feature is supported if set. Word 86, bit 3 indicates that Advanced Power Management is enabled if set. Word 96, bits 7-0 contain the current Advanced Power Management level if Advanced Power Management is enabled.

10.5.1 Performance Idle mode

This mode is usually entered immediately after Active mode command processing is complete, instead of conventional idle mode. In Performance Idle mode, all electronic components remain powered and full frequency servo remains operational. This provides instantaneous response to the next command. The duration of this mode is intelligently managed as described below.

10.5.2 Active Idle mode

In this mode, power consumption is 45-55% less than that of Performance Idle mode. Additional electronics are powered off, and the head is parked near the mid-diameter of the disk without servoing. Recovery time to Active mode is about 20ms.

10.5.3 Low Power Idle mode

Power consumption is 60%-65% less than that of Performance Idle mode. The heads are unloaded on the ramp, however the spindle is still rotated at the full speed. Recovery time to Active mode is about 300ms.

10.5.4 Transition Time

The transition time is dynamically managed by users recent access pattern, instead of fixed times. The ABLE-3 algorithm monitors the interval between commands instead of the command frequency of ABLE-2. The algorithm supposes that next command will come with the same command interval distribution as the previous access pattern. The algorithm calculates the expected average saving energy and response delay for next command in several transition time case based on this assumption. And it selects the most effective

transition time with the condition that the calculated response delay is shorter than the value calculated from the specified level by Set Feature Enable Adaptive Power Management command.

The optimal time to enter Active Idle mode is variable depending on the user's recent behavior. It is not possible to achieve the same level of Power savings with a fixed entry time into Active Idle because every user's data and access pattern is different. The optimum entry time changes over time.

The same algorithm works for entering into Low Power Idle mode and Standby mode, which consumes less power but needs more recovery time switching from this mode to Active mode.

10.6 S.M.A.R.T. Function

The intent of Self-monitoring, analysis and reporting technology (S.M.A.R.T) is to protect user data and prevent unscheduled system downtime that may be caused by predictable degradation and/or fault of the device. By monitoring and storing critical performance and calibration parameters, S.M.A.R.T devices employ sophisticated data analysis algorithms to predict the likelihood of near-term degradation or fault condition. By alerting the host system of a negative reliability status condition, the host system can warn the user of the impending risk of a data loss and advise the user of appropriate action.

Since S.M.A.R.T. utilizes the internal device microprocessor and other device resources, there may be some small overhead associated with its operation. However, special care has been taken in the design of the S.M.A.R.T. algorithms to minimize the impact to host system performance. Actual impact of S.M.A.R.T. overhead is dependent on the specific device design and the usage patterns of the host system. To further ensure minimal impact to the user, S.M.A.R.T. capable devices are shipped from the device manufacturer's factory with the S.M.A.R.T. feature disabled. S.M.A.R.T. capable devices can be enabled by the system OEMs at time of system integration or in the field by aftermarket products.

10.6.1 Attributes

Attributes are the specific performance or calibration parameters that are used in analyzing the status of the device. Attributes are selected by the device manufacturer based on that attribute's ability to contribute to the prediction of degrading or faulty conditions for that particular device. The specific set of attributes being used and the identity of these attributes is vendor specific and proprietary.

10.6.2 Attribute values

Attribute values are used to represent the relative reliability of individual performance or calibration attributes. Higher attribute values indicate that the analysis algorithms being used by the device are predicting a lower probability of a degrading or fault condition existing. Accordingly, lower attribute values indicate that the analysis algorithms being used by the device are predicting a higher probability of a degrading or fault condition existing. There is no implied linear reliability relationship corresponding to the numerical relationship between different attribute values for any particular attribute.

10.6.3 Attribute thresholds

Each attribute value has a corresponding attribute threshold limit which is used for direct comparison to the attribute value to indicate the existence of a degrading or faulty condition. The numerical value of the attribute thresholds are determined by the device manufacturer through design and reliability testing and analysis. Each attribute threshold represents the lowest limit to which its corresponding attribute value can be equal while still retaining a positive reliability status. Attribute thresholds are set at the device manufacturer's factory and cannot be changed in the field. The valid range for attribute thresholds is from 1 through 253 decimal.

10.6.4 Threshold exceeded condition

If one or more attribute values are less than or equal to their corresponding attribute thresholds, then the device reliability status is negative, indicating an impending degrading or faulty condition.

10.6.5 S.M.A.R.T. commands

The S.M.A.R.T. commands provide access to attribute values, attribute thresholds and other logging and reporting information.

10.6.6 S.M.A.R.T. operation with power management modes

It is recommended that, when a host system utilizes both the power management and S.M.A.R.T. features, the system enable the device's attribute autosave feature to allow the device's automatic attribute saving upon receipt of STANDBY IMMEDIATE or SLEEP commands. If the device has been set to utilize the standby timer, the device also saves attributes values prior to going from an Idle state to Standby state.

10.7 Security Mode Feature Set

Security Mode Feature Set is a powerful security feature. With a device lock password, a user can prevent unauthorized access to hard disk device even if the device is removed from the computer.

New commands are supported for this feature as below.

Security Set Password	('F1'h)
Security Unlock	('F2'h)
Security Erase Prepare	('F3'h)
Security Erase Unit	('F4'h)
Security Freeze Lock	('F5'h)
Security Disable Password	('F6'h)

10.7.1 Security mode

Following security modes are provided.

Device Locked mode	The device disables media access commands after power on. Media access commands are enabled by either a security unlock command or a security erase unit command.
Device Unlocked mode	The device enables all commands. If a password is not set this mode is entered after power on, otherwise it is entered by a security unlock or a security erase unit command.
Device Frozen mode	The device enables all commands except those which can update the device lock function, set/change password. The device enters this mode via a Security Freeze Lock command. It cannot quit this mode until power off.

10.7.2 Security level

Following security levels are provided.

High level security	When the device lock function is enabled and the User Password is forgotten the device can be unlocked via a Master Password.
Maximum level security	When the device lock function is enabled and the User Password is forgotten then only the Master Password with a Security Erase Unit command can unlock the device. Then user data is erased.

10.7.3 Password

This function can have 2 types of passwords as described below.

Master Password	When the Master Password is set, the device does NOT enable the Device Lock Function, and the device can NOT be locked with the Master Password, but the Master Password can be used for unlocking the device locked.
User Password	The User Password should be given or changed by a system user. When the User Password is set, the device enables the Device Lock Function, and then the device is locked on next power on reset or hard reset.

The system manufacturer/dealer who intends to enable the device lock function for the end users, must set the master password even if only single level password protection is required.

10.7.4 Operation example

10.7.4.1 Master Password setting

The system manufacturer/dealer can set a new Master Password from default Master Password using the Security Set Password command, without enabling the Device Lock Function.

10.7.4.2 User Password setting

When a User Password is set, the device will automatically enter lock mode the next time the device is powered on.

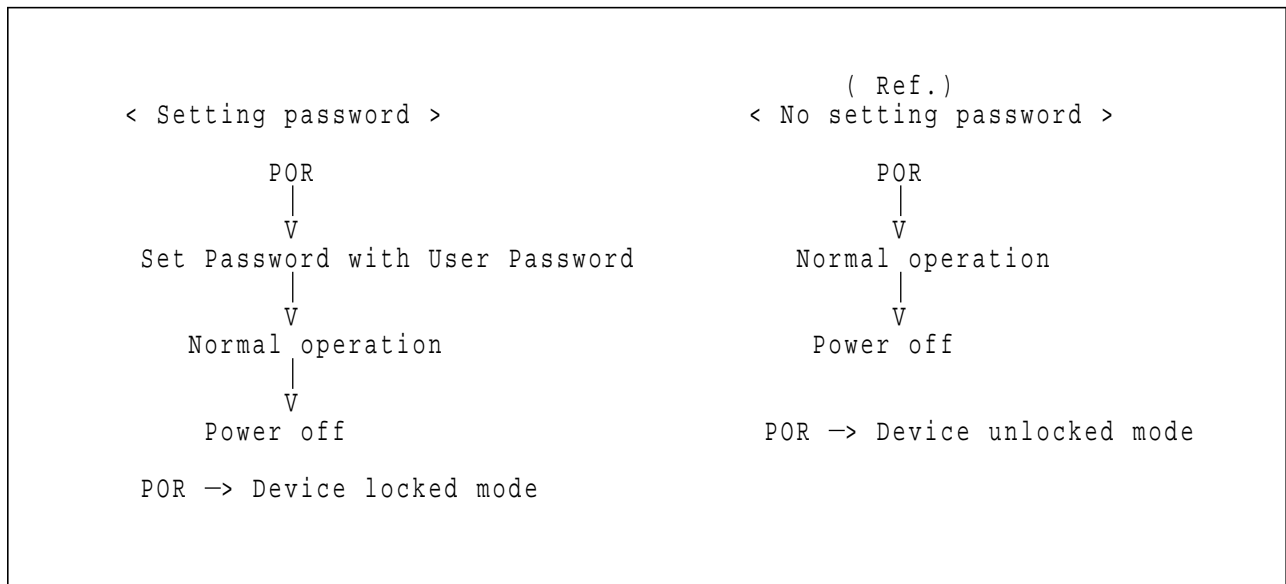

Figure 50. Initial Setting

10.7.4.3 Operation from POR after User Password is set

When Device Lock Function is enabled, the device rejects media access command until a Security Unlock command is successfully completed.

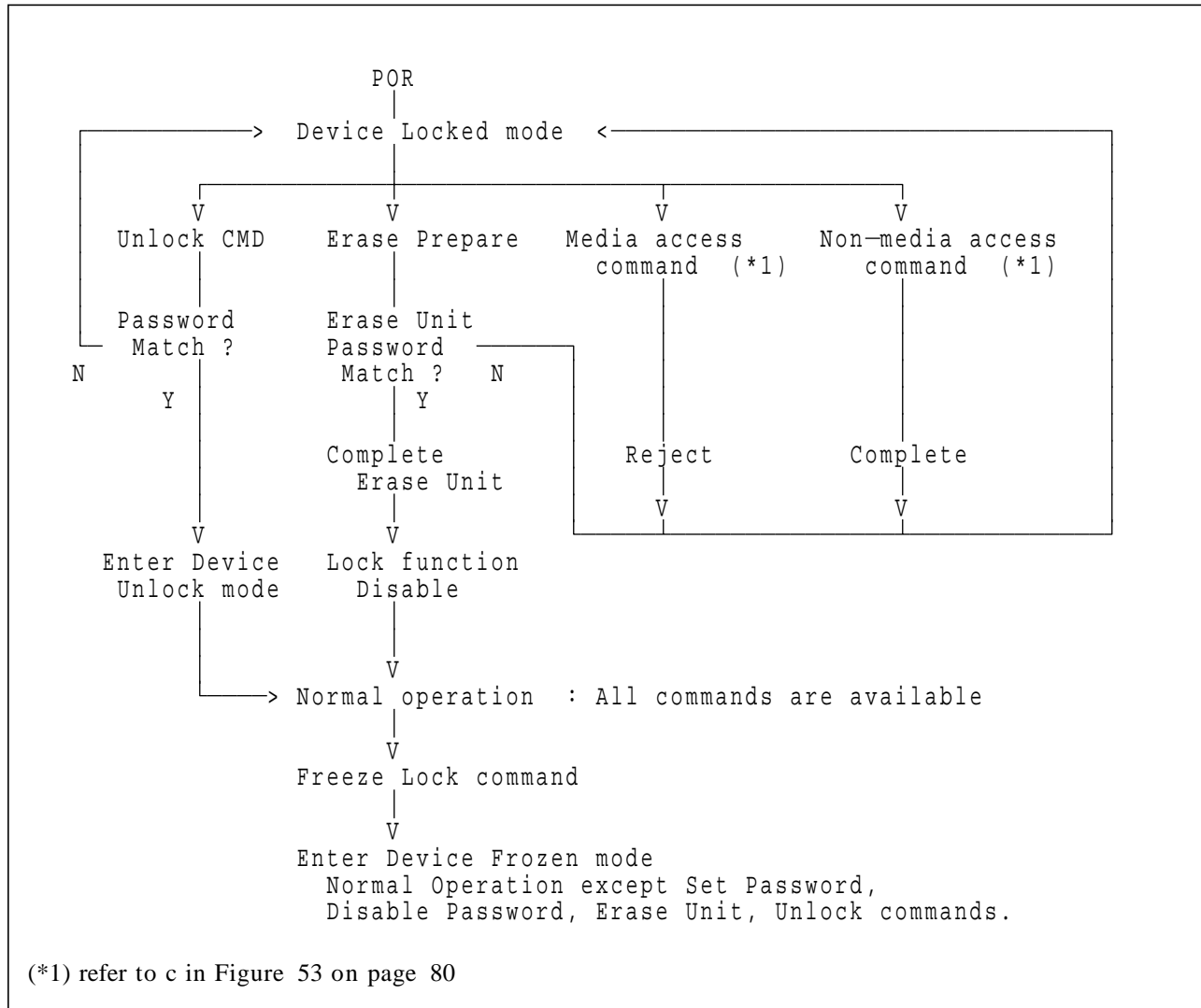

Figure 51. Usual Operation

10.7.4.4 User Password Lost

If the User Password is forgotten and High level security is set, the system user can't access any data. However the device can be unlocked using the Master Password.

If a system user forgets the User Password and Maximum security level is set, data access is impossible. However the device can be unlocked using the Security Erase Unit command to unlock the device and erase all user data with the Master Password.

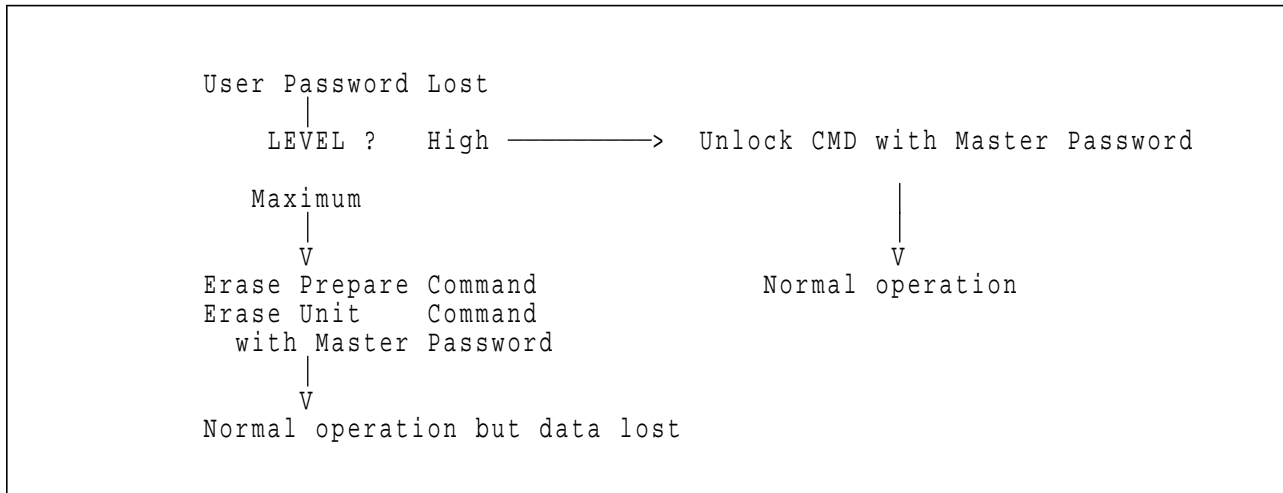

Figure 52. Password Lost

10.7.4.5 Attempt limit for SECURITY UNLOCK command

The SECURITY UNLOCK command has an attempt limit. The purpose of this attempt limit is to prevent that someone attempts to unlock the drive by using various passwords many times.

The device counts the password mismatch. If the password does not match, the device counts it up without distinguishing the Master password and the User password. If the count reaches 5, EXPIRE bit(bit 4) of Word 128 in Identify Device information is set, and then SECURITY ERASE UNIT command and SECURITY UNLOCK command are aborted until a hard reset or a power off. The count and EXPIRE bit are cleared after a power on reset or a hard reset.

10.7.5 Command Table

This table shows the device's response to commands when the Security Mode Feature Set (Device lock function) is enabled.

Command	Device Locked Mode	Device Unlock Mode	Device Frozen Mode
Check Power Mode	0	0	0
Execute Device Diagnostic	0	0	0
Flush Cache	0	0	0
Format Track	x	0	0
Format Unit	x	0	0
Identify Device	0	0	0
Identify Device DMA	0	0	0
Idle	0	0	0
Idle Immediate	0	0	0
Initialize Device Parameters	0	0	0
Read Buffer	0	0	0
Read DMA (w/o retry)	x	0	0
Read DMA (w/retry)	x	0	0
Read Long (w/o retry)	x	0	0
Read Long (w/retry)	x	0	0
Read Multiple	x	0	0
Read Native Max Address	0	0	0
Read Sector(s) (w/o retry)	x	0	0
Read Sector(s) (w/retry)	x	0	0
Read Verify Sector(s) (w/o retry)	x	0	0
Read Verify Sector(s) (w/retry)	x	0	0
Recalibrate	0	0	0
Security Disable Password	x	0	x
Security Erase Prepare	0	0	0
Security Erase Unit	0	0	x
Security Freeze Lock	x	0	0
Security Set Password	x	0	x
Security Unlock	0	0	x
Seek	0	0	0
Set Features	0	0	0
Set Max Address	0	0	0
Set Multiple Mode	0	0	0
Sleep	0	0	0

Figure 53. Command table for device lock operation -- continued --

Command	Device Locked Mode	Device Unlock Mode	Device Frozen Mode
SMART Disable Operations	o	o	o
SMART Enable/Disable Attribute Autosave	o	o	o
SMART Enable Operations	o	o	o
SMART Execute Off-line Immediate	o	o	o
SMART Read Attribute Values	o	o	o
SMART Read Attribute Thresholds	o	o	o
SMART Return Status	o	o	o
SMART Save Attribute Values	o	o	o
Standby	o	o	o
Standby Immediate	o	o	o
Write Buffer	o	o	o
Write DMA (w/o retry)	x	o	o
Write DMA (w/retry)	x	o	o
Write Long (w/o retry)	x	o	o
Write Long (w/retry)	x	o	o
Write Multiple	x	o	o
Write Sector(s) (w/o retry)	x	o	o
Write Sector(s) (w/retry)	x	o	o
Write Verify	x	o	o

- o — Device executes command normally
x — Device terminates command with error register of Aborted Command.

Figure 54. Command table for device lock operation

10.8 Protected Area Function

Protected Area Function is to provide the 'protected area' which can not be accessed via conventional method. This 'protected area' is used to contain critical system data such as BIOS or system management information. The contents of entire system main memory may also be dumped into 'protected area' to resume after system power off.

The LBA/CYL changed by following command affects the Identify Device Information.

Two commands are defined for this function.

Read Native Max Address	(‘F8’h)
Set Max Address	(‘F9’h)

10.8.1 Example for operation (In LBA mode)

Assumptions :

For better understanding, the following example uses actual values for LBA, size, etc. Since it is just an example, these values could be different.

Device characteristics

Capacity (native)	: 536,870,912 byte (536MB)
Max LBA (native)	: 1,048,575 (0FFFFFFh)
Required size for protected area	: 8,388,608 byte
Required blocks for protected area	: 16,384 (004000h)
Customer usable device size	: 528,482,304 byte (528MB)
Customer usable sector count	: 1,032,192 (0FC000h)
LBA range for protected area	: 0FC000h to 0FFFFFFh

1. Shipping HDDs from HDD manufacturer

When the HDDs are shipped from HDD manufacturer, the device has been tested to have a capacity of 536MB, flagging the media defects not to be visible by system.

2. Preparing HDDs at system manufacturer

Special utility software is required to define the size of protected area and store the data into it. The sequence is :

Issue Read Native Max Address command to get the real device max of LBA/CYL. Returned value shows that native device Max LBA is 0FFFFFFh regardless to the current setting.

Make entire device be accessible including the protected area by setting device Max LBA as 0FFFFFFh via Set Max Address command. The option could be either nonvolatile or volatile.

Test the sectors for protected area (LBA > = 0FC000h) if required.

Write information data such as BIOS code within the protected area.

Change maximum LBA using Set Max Address command to 0FBFFFh with nonvolatile option.

From this point, the protected area cannot be accessed until next Set Max Address command is issued. Any BIOSes, device drivers, or application software access the HDD as if that is the 528MB device because the device acts exactly same as real 528MB device does.

3. Conventional usage without system software support

Since the HDD works as 528MB device, there is no special care to use this device for normal use.

4. Advanced usage using protected area

The data in the protected area is accessed by following.

Issue Read Native Max Address command to get the real device max

LBA/CYL. Returned value shows that native device Max LBA is 0FFFFFFh regardless of the current setting.

Make entire device be accessible including the protected area by setting device Max LBA as 0FFFFFFh via Set Max Address command with volatile option. By using this option, unexpected power removal or reset will not make the protected area remained accessible.

Read information data from protected area.

Issue hard reset or POR to inhibit any access to the protected area.

10.9 Address Offset Feature (Vendor Specific)

Computer systems perform initial code loading (booting) by reading from a predefined address on a disk drive. To allow an alternate bootable operating system to exist in a reserved area on a disk drive this feature provides a Set Features function to temporarily offset the drive address space. The offset address space wraps around so that the entire disk drive address space remains addressable in offset mode. The Set Max pointer is set to the end of the reserved area to protect the data in the user area when operating in offset mode. This protection can be removed by an Set Max Address command to move the Set Max pointer to the end of the drive. But any commands which access sectors across the original native maximum LBA are rejected with error, even if this protection is removed by an Set Max Address command.

10.9.1 Enable/Disable Address Offset Mode

Subcommand code 09h Enable Address Offset Mode offsets address Cylinder 0, Head 0, Sector 1, LBA 0, to the start of the non-volatile protected area established using the Set Max Address command. The offset condition is cleared by Subcommand 89h Disable Address Offset Mode, Hardware reset or Power on Reset. If Reverting to Power on Defaults has been enabled by Set Features command, it is cleared by Soft reset as well. Upon entering offset mode the capacity of the drive returned in the Identify Device data is the size of the former protected area. A subsequent Set Max Address command with the address returned by Read Max Address command allows access to the entire drive. Addresses wrap so the entire drive remains addressable.

If a non-volatile protected area has not been established before the device receives a Set Features Enable Address Offset Mode command the command fails with Abort error status.

Disable Address Offset Feature removes the address offset and sets the size of the drive reported by the Identify Device command back to the size specified in the last non-volatile Set Max Address command.

- Before Enable Address Offset Mode
A reserved area has been created using a non-volatile Set Max command.

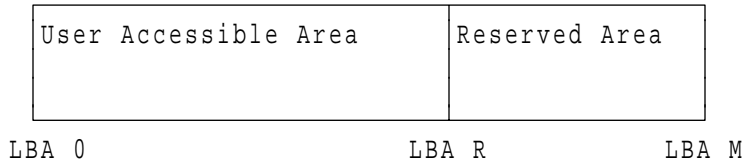

- After Enable Address Offset Mode
The former reserved area is now the user accessible area.
The former user accessible area is now the reserved area.

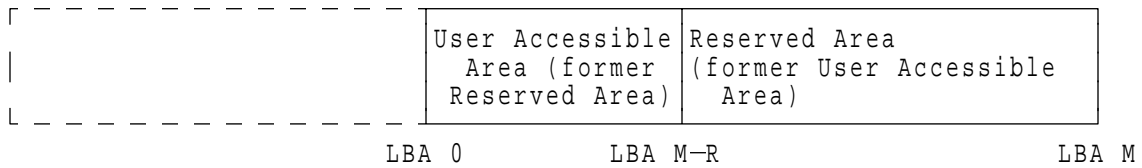

- After Set Max Address Command using the Value Returned by Read Max Address

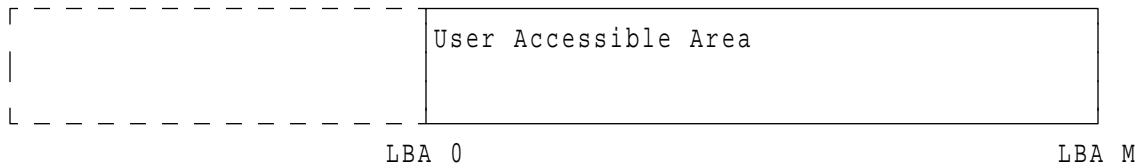

Figure 55. Device address map before and after Set Feature

10.9.2 Identify Device Data

Identify Device data word 83 bit 7 indicates the device supports the Address Offset Feature.

Identify Device data word 86 bit 7 indicates the device is in Address Offset mode.

10.9.3 Exceptions in Address Offset Mode

Any commands which access sectors across the original native maximum LBA are rejected with error, even if the access protection is removed by an Set Max Address command.

Read Look Ahead operation does not be carried out, even if it is enabled by Set Feature command.

10.10 Write Cache Function

Write cache is a performance enhancement whereby the device reports completion of the write command (Write Sectors and Write Multiple) to the host as soon as the device has received all of the data into its buffer. The device assumes responsibility to write the data subsequently onto the disk.

- While writing data after completed acknowledgment of a write command, soft reset or hard reset does not affect its operation. But power off terminates writing operation immediately and unwritten data are to be lost.
- Flush cache, Soft reset and Check Power Mode command are executed after the completion of writing to disk media on enabling write cache function. So the host system can confirm the completion of write cache operation by issuing flush cache command, Soft reset, or Check Power Mode command, and then, by confirming its completion.
- The retry bit of Write Sectors is ignored when write cache is enabled.

10.11 Reassign Function

The reassign Function is used with read commands and write commands. The sectors of data for reassignment are prepared as the spare data sector. The assured number of the spare sectors is a minimum of 3795 sectors.

This reassignment information is registered internally, and the information is available right after completing the reassign function. Also the information is used on the next power on reset or hard reset.

If the number of the spare sector reaches 0 sector, the reassign function will be disabled automatically.

The spare sectors for reassignment are located at reserved area. As a result of reassignment, the physical location of logically sequenced sectors will be dispersed.

10.11.1 Auto Reassign Function

The sectors that show some errors may be reallocated automatically when specific conditions are met. The spare sectors for reallocation are located at reserved area. The conditions for auto-reallocation are described below.

When a device shipped from IBM, a minimum of 791 usable spare sectors are available.

Non recovered write errors

When a write operation can not be completed after the Error Recovery Procedure(ERP) is fully carried out, the sector(s) are reallocated to the spare location. An error is reported to the host system only when the write cache is disabled and the auto reallocation fails.

If the number of available spare sectors reaches 16 sectors, the write cache function will be disabled automatically.

If the command is without retry and the write cache function is disabled, the auto reassign function is not invoked.

Non recovered read errors

When a read operation fails after defined ERP is fully carried out, a hard error is reported to the host system. This location is registered internally as a candidate for the reallocation. When a registered location is specified as a target of a write operation, a sequence of media verification is performed automatically. When the result of this verification meets the criteria, this sector is reallocated.

Recovered read errors

When a read operation for a sector failed once then recovered at the specific ERP step, this sector of data is reallocated automatically. A media verification sequence may be run prior to the relocation according to the pre-defined conditions.

11.0 Command Protocol

The commands are grouped into different classes according to the protocols followed for command execution. The command classes with their associated protocols are defined below.

For all commands, the host must first check if BSY=1, and should proceed no further unless and until BSY=0. For all commands, the host must also wait for RDY=1 before proceeding.

A device must maintain either BSY=1 or DRQ=1 at all times until the command is completed. The INTRQ signal is used by the device to signal most, but not all, times when the BSY bit is changed from 1 to 0 during command execution.

A command shall only be interrupted with a hardware or software reset. The result of writing to the Command register while BSY=1 or DRQ=1 is unpredictable and may result in data corruption. A command should only be interrupted by a reset at times when the host thinks there may be a problem, such as a device that is no longer responding.

Interrupts are cleared when the host reads the Status Register, issues a reset, or writes to the Command Register.

Figure 113 on page 171 shows the device timeout values.

11.1 Data In Commands

These commands are:

- Identify Device
- Read Buffer
- Read Long
- Read Multiple
- Read Sectors
- SMART Read Attribute Values
- SMART Read Attribute Thresholds

Execution includes the transfer of one or more 512 byte (>512 bytes on Read Long) sectors of data from the device to the host.

1. The host writes any required parameters to the Features, Sector Count, Sector Number, Cylinder, and Device/Head Registers.
2. The host writes the command code to the Command Register.
3. For each sector (or block) of data to be transferred:
 - a. The device sets BSY=1 and prepares for data transfer.
 - b. When a sector (or block) of data is available for transfer to the host, the device sets BSY=0, sets DRQ=1, and interrupts the host.
 - c. In response to the interrupt, the host reads the Status Register.
 - d. The device clears the interrupt in response to the Status Register being read.
 - e. The host reads one sector (or block) of data via the Data Register.

- f. The device sets DRQ=0 after the sector (or block) has been transferred to the host.
4. For the Read Long command:
 - a. The device sets BSY=1 and prepares for data transfer.
 - b. When the sector of data is available for transfer to the host, the device sets BSY=0, sets DRQ=1, and interrupts the host.
 - c. In response to the interrupt, the host reads the Status Register.
 - d. The device clears the interrupt in response to the Status Register being read.
 - e. The host reads the sector of data including ECC bytes via the Data Register.
 - f. The device sets DRQ=0 after the sector has been transferred to the host.

The Read Multiple command transfers one block of data for each interrupt. The other commands transfer one sector of data for each interrupt.

Note that the status data for a sector of data is available in the Status Register **before** the sector is transferred to the host.

If the device detects an invalid parameter, then it will abort the command by setting BSY=0, ERR=1, ABT=1, and interrupting the host.

If an error occurs, the device will set BSY=0, ERR=1, and DRQ=1. The device will then store the error status in the Error Register, and interrupt the host. The registers will contain the location of the sector in error. The errored location will be reported with CHS mode or LBA mode, the mode is decided by mode select bit (bit 6) of Device/Head register on issuing the command.

If an Uncorrectable Data Error (UNC=1) occurs, the defective data will be transferred from the media to the sector buffer, and will be available to be transferred to the host, at the host's option. In case of Read Multiple command, the host should complete transfer the block which includes the error from the sector buffer and terminate whatever kind of type of error occurred.

If an error occurs that is correctable by retries, the data will be corrected and the transfer will continue normally. There will be no indication to the host that any retry occurred.

All data transfers to the host through the Data Register are 16 bits, except for the ECC bytes, which are 8 bits.

11.2 Data Out Commands

These commands are:

- Format Track
- Security Disable Password
- Security Erase Unit
- Security Set Password
- Security Unlock
- Write Buffer
- Write Long
- Write Multiple

- Write Sectors
- Write Verify

Execution includes the transfer of one or more 512 byte (>512 bytes on Write Long) sectors of data from the host to the device.

1. The host writes any required parameters to the Features, Sector Count, Sector Number, Cylinder, and Device/Head Registers.
2. The host writes the command code to the Command Register.
3. The device sets BSY=1.
4. For each sector (or block) of data to be transferred:
 - a. The device sets BSY=0 and DRQ=1 when it is ready to receive a sector (or block).
 - b. The host writes one sector (or block) of data via the Data Register.
 - c. The device sets BSY=1 after it has received the sector (or block).
 - d. When the device has finished processing the sector (or block), it sets BSY=0, and interrupts the host.
 - e. In response to the interrupt, the host reads the Status Register.
 - f. The device clears the interrupt in response to the Status Register being read.
5. For the Write Long command:
 - a. The device sets BSY=0 and DRQ=1 when it is ready to receive a sector.
 - b. The host writes one sector of data including ECC bytes via the Data Register.
 - c. The device sets BSY=1 after it has received the sector.
 - d. After processing the sector of data the device sets BSY=0 and interrupts the host.
 - e. In response to the interrupt, the host reads the Status Register.
 - f. The device clears the interrupt in response to the Status Register being read.

The Write Multiple command transfers one block of data for each interrupt. The other commands transfer one sector of data for each interrupt.

If the device detects an invalid parameter, then it will abort the command by setting BSY=0, ERR=1, ABT=1, and interrupting the host.

If an uncorrectable error occurs, the device will set BSY=0 and ERR=1, store the error status in the Error Register, and interrupt the host. The registers will contain the location of the sector in error. The errored location will be reported with CHS mode or LBA mode. The mode is decided by mode select bit (bit 6) of Device/Head register on issuing the command.

All data transfers to the device through the Data Register are 16 bits, except for the ECC bytes, which are 8 bits.

11.3 Non-Data Commands

These commands are:

- Check Power Mode
- Execute Device Diagnostic
- Flush Cache
- Format Unit
- Idle
- Idle Immediate
- Initialize Device Parameters
- Read Native Max Address
- Read Verify Sectors
- Recalibrate
- Security Erase Prepare
- Security Freeze Lock
- Seek
- Set Features
- Set Max Address
- Set Multiple Mode
- Sleep
- SMART Disable Operations
- SMART Enable/Disable Attribute Autosave
- SMART Enable Operations
- SMART Execute Off-line Immediate
- SMART Return Status
- SMART Save Attribute Values
- Standby
- Standby Immediate

Execution of these commands involves no data transfer.

1. The host writes any required parameters to the Features, Sector Count, Sector Number, Cylinder, and Device/Head Registers.
2. The host writes the command code to the Command Register.
3. The device sets BSY=1.
4. When the device has finished processing the command, it sets BSY=0, and interrupts the host.
5. In response to the interrupt, the host reads the Status Register.
6. The device clears the interrupt in response to the Status Register being read.

11.4 DMA Data Transfer Commands

These commands are:

- Identify Device DMA
- Read DMA
- Write DMA

Data transfer using DMA commands differ in two ways from PIO transfers:

- data transfers are performed using the slave-DMA channel
- no intermediate sector interrupts are issued on multi-sector commands

Initiation of the DMA transfer commands is identical to the Read Sector or Write Sector commands except that the host initializes the slave-DMA channel prior to issuing the command.

The interrupt handler for DMA transfers is different in that:

- no intermediate sector interrupts are issued on multi-sector commands
- the host resets the DMA channel prior to reading status from the device.

The DMA protocol allows high performance multi-tasking operating systems to eliminate processor overhead associated with PIO transfers.

1. Host initializes the slave-DMA channel
2. Host writes any required parameters to the Features, Sector Count, Sector Number, Cylinder and Device/Head registers.
3. Host writes command code to the Command Register
4. The device sets DMARQ when it is ready to transfer any part of the data.
5. Host transfers the data using the DMA transfer protocol currently in effect.
6. When all of the data has been transferred, the device generates an interrupt to the host.
7. Host resets the slave-DMA channel
8. Host reads the Status Register and, optionally, the Error Register

12.0 Command Descriptions

Proto col	Command	Code (Hex)	Binary Code Bit							
			7	6	5	4	3	2	1	0
3	Check Power Mode	E5	1	1	1	0	0	1	0	1
3	Check Power Mode*	98	1	0	0	1	1	0	0	0
3	Execute Device Diagnostic	90	1	0	0	1	0	0	0	0
3	Flush Cache	E7	1	1	1	0	0	1	1	1
2	Format Track	50	0	1	0	1	0	0	0	0
3+	Format Unit	F7	1	1	1	1	0	1	1	1
1	Identify Device	EC	1	1	1	0	1	1	0	0
4	Identify Device DMA	EE	1	1	1	0	1	1	1	0
3	Idle	E3	1	1	1	0	0	0	1	1
3	Idle*	97	1	0	0	1	0	1	1	1
3	Idle Immediate	E1	1	1	1	0	0	0	0	1
3	Idle Immediate*	95	1	0	0	1	0	1	0	1
3	Initialize Device Parameters	91	1	0	0	1	0	0	0	1
1	Read Buffer	E4	1	1	1	0	0	1	0	0
4	Read DMA (retry)	C8	1	1	0	0	1	0	0	0
4	Read DMA (no retry)	C9	1	1	0	0	1	0	0	1
1	Read Long (retry)	22	0	0	1	0	0	0	1	0
1	Read Long (no retry)	23	0	0	1	0	0	0	1	1
1	Read Multiple	C4	1	1	0	0	0	1	0	0
3	Read Native Max Address	F8	1	1	1	1	1	0	0	0
1	Read Sectors (retry)	20	0	0	1	0	0	0	0	0
1	Read Sectors (no retry)	21	0	0	1	0	0	0	0	1
3	Read Verify Sectors (retry)	40	0	1	0	0	0	0	0	0
3	Read Verify Sectors (no retry)	41	0	1	0	0	0	0	0	1
3	Recalibrate	1x	0	0	0	1	—	—	—	—
2	Security Disable Password	F6	1	1	1	1	1	0	1	0
3	Security Erase Prepare	F3	1	1	1	1	0	0	1	1
2	Security Erase Unit	F4	1	1	1	1	0	1	0	0
3	Security Freeze Lock	F5	1	1	1	1	0	1	0	1
2	Security Set Password	F1	1	1	1	1	0	0	0	1
2	Security Unlock	F2	1	1	1	1	0	0	1	0
3	Seek	7x	0	1	1	1	—	—	—	—
3	Set Features	EF	1	1	1	0	1	1	1	1
3	Set Max Address	F9	1	1	1	1	1	0	0	1
3	Set Multiple Mode	C6	1	1	0	0	0	1	1	0

Figure 56. Command Set -- continued --

Protocol	Command	Code (Hex)	Binary Code Bit							
			7	6	5	4	3	2	1	0
3	Sleep	E6	1	1	1	0	0	1	1	0
3	Sleep*	99	1	0	0	1	1	0	0	1
3	SMART Disable Operations	B0	1	0	1	1	0	0	0	0
3	SMART Enable/Disable Attribute Autosave	B0	1	0	1	1	0	0	0	0
3	SMART Enable Operations	B0	1	0	1	1	0	0	0	0
3	SMART Execute Off-line Immediate	B0	1	0	1	1	0	0	0	0
1	SMART Read Attribute Values	B0	1	0	1	1	0	0	0	0
1	SMART Read Attribute Thresholds	B0	1	0	1	1	0	0	0	0
3	SMART Return Status	B0	1	0	1	1	0	0	0	0
3	SMART Save Attribute Values	B0	1	0	1	1	0	0	0	0
3	Standby	E2	1	1	1	0	0	0	1	0
3	Standby*	96	1	0	0	1	0	1	1	0
3	Standby Immediate	E0	1	1	1	0	0	0	0	0
3	Standby Immediate*	94	1	0	0	1	0	1	0	0
2	Write Buffer	E8	1	1	1	0	1	0	0	0
4	Write DMA (retry)	CA	1	1	0	0	1	0	1	0
4	Write DMA (no retry)	CB	1	1	0	0	1	0	1	1
2	Write Long (retry)	32	0	0	1	1	0	0	1	0
2	Write Long (no retry)	33	0	0	1	1	0	0	1	1
2	Write Multiple	C5	1	1	0	0	0	1	0	1
2	Write Sectors (retry)	30	0	0	1	1	0	0	0	0
2	Write Sectors (no retry)	31	0	0	1	1	0	0	0	1
2	Write Verify	3C	0	0	1	1	1	1	0	0

Protocol : 1 : PIO data IN command
2 : PIO data OUT command
3 : Non data command
4 : DMA command
+ : Vendor specific command

Figure 57. Command Set

Commands marked * are alternate command codes for previously defined commands.

Command (Subcommand)	Command Code (Hex)	Feature Register (Hex)
(S.M.A.R.T function)		
SMART Read Attribute Values	B0	D0
SMART Read Attribute Thresholds	B0	D1
SMART Enable/Disable Attribute Autosave	B0	D2
SMART Save Attribute Values	B0	D3
SMART Execute Off-line Immediate	B0	D4
SMART Enable Operations	B0	D8
SMART Disable Operations	B0	D9
SMART Return Status	B0	DA
(Set Features)		
Enable Write Cache	EF	02
Set Transfer Mode	EF	03
Enable Advanced Power Management feature	EF	05
Enable Address Offset mode	EF	09
34 bytes of ECC apply on Read/Write Long	EF	44
Disable read look-ahead feature	EF	55
Disable reverting to power on defaults	EF	66
Disable write cache	EF	82
Disable Advanced Power Management feature	EF	85
Disable Address Offset mode	EF	89
Enable read look-ahead feature	EF	AA
4 bytes of ECC apply on Read/Write Long	EF	BB
Enable reverting to power on defaults	EF	CC

Figure 58. Command Set (Subcommand)

Figure 56 on page 95 and Figure 57 on page 96 shows the commands that are supported by the device. Figure 58 shows the sub-commands that are supported by each command or feature.

The following symbols are used in the command descriptions:

Output Registers

- 0** Indicates that the bit must be set to 0.
- 1** Indicates that the bit must be set to 1.
- D** The device number bit. Indicates that the device number bit of the Device/Head Register should be specified. Zero selects the master device and one selects the slave device.
- H** Head number. Indicates that the head number part of the Device/Head Register is an output parameter and should be specified.
- L** LBA mode. Indicates the addressing mode. Zero specifies CHS mode and one does LBA addressing mode.
- R** Retry. Indicates that the Retry bit of the Command Register should be specified.
- B** Option Bit. Indicates that the Option Bit of the Sector Count Register should be specified. (This bit is used by Set Max Address command)
- V** Valid. Indicates that the bit is part of an output parameter and should be specified.
- x** Indicates that the hex character is not used.
- Indicates that the bit is not used.

Input Registers

- 0** Indicates that the bit is always set to 0.
- 1** Indicates that the bit is always set to 1.
- H** Head number. Indicates that the head number part of the Device/Head Register is an input parameter and will be set by the device.
- V** Valid. Indicates that the bit is part of an input parameter and will be set to 0 or 1 by the device.
- Indicates that the bit is not part of an input parameter.

The command descriptions show the contents of the Status and Error Registers after the device has completed processing the command and has interrupted the host.

12.1 Check Power Mode (E5h/98h)

Command Block Output Registers								
Register	7	6	5	4	3	2	1	0
Data	-	-	-	-	-	-	-	-
Feature	-	-	-	-	-	-	-	-
Sector Count	-	-	-	-	-	-	-	-
Sector Number	-	-	-	-	-	-	-	-
Cylinder Low	-	-	-	-	-	-	-	-
Cylinder High	-	-	-	-	-	-	-	-
Device/Head	1	-	1	D	-	-	-	-
Command	1	1	1	0	0	1	0	1

Command Block Input Registers								
Register	7	6	5	4	3	2	1	0
Data	-	-	-	-	-	-	-	-
Error	...See Below...							
Sector Count	V	V	V	V	V	V	V	V
Sector Number	-	-	-	-	-	-	-	-
Cylinder Low	-	-	-	-	-	-	-	-
Cylinder High	-	-	-	-	-	-	-	-
Device/Head	-	-	-	-	-	-	-	-
Status	...See Below...							

Error Register							
7	6	5	4	3	2	1	0
CRC	UNC	0	IDN	0	ABT	T0N	AMN
0	0	0	0	0	V	0	0

Status Register							
7	6	5	4	3	2	1	0
BSY	RDY	DF	DSC	DRQ	COR	IDX	ERR
0	0	0	-	-	0	-	V

Figure 59. Check Power Mode Command (E5h/98h)

The Check Power Mode command will report whether the device is spun up and the media is available for immediate access.

Input Parameters From The Device

Sector Count The power mode code. The command returns FFh in the Sector Count Register if the spindle motor is at speed and the device is not in Standby or Sleep mode. Otherwise, the Sector Count Register will be set to 0.

12.2 Execute Device Diagnostic (90h)

Command Block Output Registers								
Register	7	6	5	4	3	2	1	0
Data	-	-	-	-	-	-	-	-
Feature	-	-	-	-	-	-	-	-
Sector Count	-	-	-	-	-	-	-	-
Sector Number	-	-	-	-	-	-	-	-
Cylinder Low	-	-	-	-	-	-	-	-
Cylinder High	-	-	-	-	-	-	-	-
Device/Head	1	-	1	-	-	-	-	-
Command	1	0	0	1	0	0	0	0

Command Block Input Registers								
Register	7	6	5	4	3	2	1	0
Data	-	-	-	-	-	-	-	-
Error	...See Below...							
Sector Count	-	-	-	-	-	-	-	-
Sector Number	-	-	-	-	-	-	-	-
Cylinder Low	-	-	-	-	-	-	-	-
Cylinder High	-	-	-	-	-	-	-	-
Device/Head	-	-	-	-	-	-	-	-
Status	...See Below...							

Error Register							
7	6	5	4	3	2	1	0
CRC	UNC	0	IDN	0	ABT	T0N	AMN
0	V	V	V	V	V	V	V

Status Register							
7	6	5	4	3	2	1	0
BSY	RDY	DF	DSC	DRQ	COR	IDX	ERR
0	0	0	-	-	0	-	0

Figure 60. Execute Device Diagnostic Command (90h)

The Execute Device Diagnostic command performs the internal diagnostic tests implemented by the device. The results of the test are stored in the Error Register.

The normal Error Register bit definitions do not apply to this command. Instead, the register contains a diagnostic code. See Figure 47 on page 67 for the definition.

12.3 Flush Cache (E7h)

Command Block Output Registers								
Register	7	6	5	4	3	2	1	0
Data	-	-	-	-	-	-	-	-
Feature	-	-	-	-	-	-	-	-
Sector Count	-	-	-	-	-	-	-	-
Sector Number	-	-	-	-	-	-	-	-
Cylinder Low	-	-	-	-	-	-	-	-
Cylinder High	-	-	-	-	-	-	-	-
Device/Head	1	-	1	D	-	-	-	-
Command	1	1	1	0	0	1	1	1

Command Block Input Registers								
Register	7	6	5	4	3	2	1	0
Data	-	-	-	-	-	-	-	-
Error	...See Below...							
Sector Count	-	-	-	-	-	-	-	-
Sector Number	-	-	-	-	-	-	-	-
Cylinder Low	-	-	-	-	-	-	-	-
Cylinder High	-	-	-	-	-	-	-	-
Device/Head	-	-	-	-	-	-	-	-
Status	...See Below...							

Error Register							
7	6	5	4	3	2	1	0
CRC	UNC	0	IDN	0	ABT	T0N	AMN
0	0	0	0	0	V	0	0

Status Register							
7	6	5	4	3	2	1	0
BSY	RDY	DF	DSC	DRQ	COR	IDX	ERR
0	V	0	V	-	0	-	V

Figure 61. Flush Cache Command (E7h)

This command causes the device to complete writing data from its cache.

The device returns a status, RDY=1 and DSC=1 (50h), after following sequence.

- Data in the write cache buffer is written to disk media.
- Return a successfully completion.

12.4 Format Track (50h: Vendor Specific)

Command Block Output Registers								
Register	7	6	5	4	3	2	1	0
Data	-	-	-	-	-	-	-	-
Feature	-	-	-	-	-	-	-	-
Sector Count	-	-	-	-	-	-	-	-
Sector Number	V	V	V	V	V	V	V	V
Cylinder Low	V	V	V	V	V	V	V	V
Cylinder High	V	V	V	V	V	V	V	V
Device/Head	1	L	1	D	H	H	H	H
Command	0	1	0	1	0	0	0	0

Command Block Input Registers								
Register	7	6	5	4	3	2	1	0
Data	-	-	-	-	-	-	-	-
Error	...See Below...							
Sector Count	-	-	-	-	-	-	-	-
Sector Number	V	V	V	V	V	V	V	V
Cylinder Low	V	V	V	V	V	V	V	V
Cylinder High	V	V	V	V	V	V	V	V
Device/Head	-	-	-	-	H	H	H	H
Status	...See Below...							

Error Register							
7	6	5	4	3	2	1	0
CRC	UNC	0	IDN	0	ABT	T0N	AMN
0	0	0	V	0	V	0	0

Status Register							
7	6	5	4	3	2	1	0
BSY	RDY	DF	DSC	DRQ	COR	IDX	ERR
0	V	V	V	-	0	-	V

Figure 62. Format Track Command (50h)

The Format Track command formats a single logical track on the device. Each good sector of data on the track will be initialized to zero with write operation. At this time, whether the sector of data is initialized correctly is not verified with read operation. Any data previously stored on the track will be lost.

The host transfers a sector of data containing a format table to the device. The format table should contain two bytes for each sector on the track to be formatted. The structure of format table is shown in Figure 63 on page 103. The first byte should contain a descriptor value and the second byte should contain the sector number. The descriptor value should be 0 for a good sector, and any other descriptor value will cause an aborted error. The remaining bytes of the sector following the format table are ignored.

Since device performance is optimal at 1:1 interleave, and the device uses relative block addressing internally, the device will always format a track in the same way no matter what sector numbering is specified in the format table.

Output Parameters To The Device

Sector Number In LBA mode, this register specifies LBA address bits 0 - 7 to be formatted. (L=1)

Cylinder High/Low The cylinder number of the track to be formatted. (L=0)

In LBA mode, this register specifies LBA address bits 8 - 15 (Low), 16 - 23 (High) to be formatted. (L=1)

H The head number of the track to be formatted. (L=0)

In LBA mode, this register specifies LBA address bits 24 - 27 to be formatted. (L=1)

Input Parameters From The Device

- Sector Number** In LBA mode, this register specifies current LBA address bits 0-7. (L=1)
- Cylinder High/Low** In LBA mode, this register specifies current LBA address bits 8 - 15 (Low), 16 - 23 (High)
- H** In LBA mode, this register specifies current LBA address bits 24 - 27. (L=1)
- Error** The Error Register. An Abort error (ABT=1) will be returned under the following conditions:
- The descriptor value does not match the certain value. (except 00h)

In LBA mode, this command formats a single logical track including the specified LBA.

Explanation for descriptor

Descriptor : 00h The sector of data will be initialized to 00h.

Byte	Data	Description
0 1	xxh 00h	descriptor value for sector number 00h sector number
2 3	xxh 01h	descriptor value for sector number 01h sector number
4 5	xxh 02h	descriptor value for sector number 02h sector number
:	:	
:	:	
N*2 N*2+1	xxh N	descriptor value for sector number N sector number (last sector for the track)
N*2+2 N*2+3	00h 00h	remainder of buffer filled with 00h
:	:	
:	:	
510 511	00h 00h	

Descriptor : 00h – Format sector as good sector

Figure 63. Format track data field format

12.5 Format Unit (F7h: Vendor Specific)

Command Block Output Registers								
Register	7	6	5	4	3	2	1	0
Data	-	-	-	-	-	-	-	-
Feature	V	V	V	V	V	V	V	V
Sector Count	-	-	-	-	-	-	-	-
Sector Number	-	-	-	-	-	-	-	-
Cylinder Low	-	-	-	-	-	-	-	-
Cylinder High	-	-	-	-	-	-	-	-
Device/Head	1	-	1	D	-	-	-	-
Command	1	1	1	1	0	1	1	1

Command Block Input Registers								
Register	7	6	5	4	3	2	1	0
Data	-	-	-	-	-	-	-	-
Error	...See Below...							
Sector Count	-	-	-	-	-	-	-	-
Sector Number	-	-	-	-	-	-	-	-
Cylinder Low	-	-	-	-	-	-	-	-
Cylinder High	-	-	-	-	-	-	-	-
Device/Head	-	-	-	-	-	-	-	-
Status	...See Below...							

Error Register							
7	6	5	4	3	2	1	0
CRC	UNC	0	IDN	0	ABT	T0N	AMN
0	0	0	V	0	V	0	0

Status Register							
7	6	5	4	3	2	1	0
BSY	RDY	DF	DSC	DRQ	COR	IDX	ERR
0	V	0	V	-	0	-	V

Figure 64. Format Unit Command (F7h)

The Format Unit command initializes all user data sectors after merging reassigned sector location into the defect information of the device and clearing the reassign information. Both new reassign information and new defect information are available right after this command completion, and are also used on next power on reset or hard reset. Both previous information are erased from the device by this command.

Note that the Format Unit command initializes from LBA 0 to Native MAX LBA. Host MAX LBA set by Initialize Drive Parameter or Set MAX Address command is ignored. So the protected area by Set Max Address command is also initialized.

The security erase prepare command should be completed immediately prior to the Format Unit command. If the device receives a Format Unit command without a prior Security Erase Prepare command the device aborts the Format Unit command.

If Feature register is NOT 11h, the device returns Abort error to the host.

This command does not request to data transfer.

Output Parameters To The Device

Feature Destination code for this command.
11H Merge reassigned location into the defect information

The execution time of this command is shown below.

DCXA-210000 about 22 min

DCXA-208100 about 19 min

12.6 Identify Device (ECh)

Command Block Output Registers								
Register	7	6	5	4	3	2	1	0
Data	-	-	-	-	-	-	-	-
Feature	-	-	-	-	-	-	-	-
Sector Count	-	-	-	-	-	-	-	-
Sector Number	-	-	-	-	-	-	-	-
Cylinder Low	-	-	-	-	-	-	-	-
Cylinder High	-	-	-	-	-	-	-	-
Device/Head	1	-	1	D	-	-	-	-
Command	1	1	1	0	1	1	0	0

Command Block Input Registers								
Register	7	6	5	4	3	2	1	0
Data	-	-	-	-	-	-	-	-
Error	...See Below...							
Sector Count	-	-	-	-	-	-	-	-
Sector Number	-	-	-	-	-	-	-	-
Cylinder Low	-	-	-	-	-	-	-	-
Cylinder High	-	-	-	-	-	-	-	-
Device/Head	-	-	-	-	-	-	-	-
Status	...See Below...							

Error Register							
7	6	5	4	3	2	1	0
CRC	UNC	0	IDN	0	ABT	T0N	AMN
0	0	0	0	0	V	0	0

Status Register							
7	6	5	4	3	2	1	0
BSY	RDY	DF	DSC	DRQ	COR	IDX	ERR
0	V	0	-	-	0	-	V

Figure 65. Identify Device Command (ECh)

The Identify Device command requests the device to transfer configuration information to the host. The device will transfer a sector to the host containing the information in Figure 66 on page 107.

Word	Content	Description
00	045AH	Drive classification, bit assignments: 15(=0): 1=ATAPI device, 0=ATA device * 14(=0): 1=format speed tolerance gap required * 13(=0): 1=track offset option available * 12(=0): 1=data strobe offset option available * 11(=0): 1=rotational speed tolerance > 0.5% * 10(=1): 1=disk transfer rate > 10 Mbps * 9(=0): 1=disk transfer rate > 5 Mbps but <= 10 Mbps * 8(=0): 1=disk transfer rate <= 5 Mbps 7(=0): 1=removable cartridge device 6(=1): 1=fixed device * 5(=0): 1=spindle motor control option implemented * 4(=1): 1=head switch time > 15 us * 3(=1): 1=not MFM encoded * 2(=0): 1=soft sectoring * 1(=1): 1=hard sectoring 0(=0): Reserved
01	Note.2	Number of cylinders in default translate mode
02	0	* Number of removable cylinders
03	Note.2	Number of heads in default translate mode
04	0	* Reserved
05	0	* Reserved
06	003FH	Number of sectors per track in default translate mode
07	0000H	* Number of bytes of sector gap
08	0000H	* Number of bytes in sync field
09	0000H	* Reserved
10-19	XXXX	Serial number in ASCII (0 = not specified)
20	0003H	* Controller type: 0003: dual ported, multiple sector buffer with look-ahead read
21	0349H	* Buffer size in 512-byte increments (=420KB)
22	00XXH	* Number of ECC bytes as currently selected via the set features command
23-26	Note.2	Microcode version in ASCII
27-46	Note.2	Model number in ASCII
47	0010H	Maximum number of sectors that can be transferred per interrupt on Read and Write Multiple commands
48	0000H	* Capable of double word I/O, '0000'= cannot perform
49	0F00H	Capabilities, bit assignments: 15-14(=0) Reserved 13(=0) Standby timer value are vendor specific 12(=0) Reserved 11(=1) IORDY Supported 10(=1) IORDY can be disabled 9(=1) 1=LBA Supported 8(=1) 1=DMA Supported * 7- 0(=0) Reserved

Figure 66. Identify device information -- continued --

Word	Content	Description
50	4000H	Capabilities 15(=0) 0=the contents of word 50 are valid 14(=1) 1=the contents of word 50 are valid 13- 1(=0) Reserved 0(=0) 1=the device has a minimum Standby timer value that is device specific
51	0200H	PIO data transfer cycle timing mode
52	0200H *	DMA data transfer cycle timing mode Refer Word 62 and 63
53	XXX7H	Validity flag of the word 15- 3(=0) Reserved 2(=1) 1=Word 88 is Valid 1(=1) 1=Word 64-70 are Valid 0(=1) 1=Word 54-58 are Valid
54	XXXXH	Number of current cylinders
55	XXXXH	Number of current heads
56	XXXXH	Number of current sectors per track
57-58	XXXXH	Current capacity in sectors Word 57 specifies the low word of the capacity
59	0XXXH	Current Multiple setting. bit assignments 15- 9(=0) Reserved 8 1= Multiple Sector Setting is Valid 7- 0 xxh = Current setting for number of sectors
60-61	Note.2	Total Number of User Addressable Sectors Word 60 specifies the low word of the number
62	XX07H *	Single Word DMA Transfer Capability 15- 8 Single word DMA transfer mode active 7- 0(=7) Single word DMA transfer modes supported (support mode 0,1 and 2)
63	XX07H	Multiword DMA Transfer Capability 15-11(=0) Reserved 10 1=Multiword DMA mode 2 is selected 9 1=Multiword DMA mode 1 is selected 8 1=Multiword DMA mode 0 is selected 7- 0(=7) Multi word DMA transfer modes supported (support mode 0,1 and 2)
64	0003H	Flow Control PIO Transfer Modes Supported 15- 8(=0) Reserved 7- 0(=3) Advanced PIO Transfer Modes Supported '11' = PIO Mode 3 and 4 Supported
65	0078H	Minimum Multiword DMA Transfer Cycle Time Per Word 15- 0(=78) Cycle time in nanoseconds (120ns, 16.6MB/s)
66	0078H	Manufacturer's Recommended Multiword DMA Transfer Cycle Time 15- 0(=78) Cycle time in nanoseconds (120ns, 16.6MB/s)
67	00F0H	Minimum PIO Transfer Cycle Time Without Flow Control 15- 0(=F0) Cycle time in nanoseconds (240ns, 8.3MB/s)
68	0078H	Minimum PIO Transfer Cycle Time With IORDY Flow Control 15- 0(=78) Cycle time in nanoseconds (120ns, 16.6MB/s)

Figure 67. Identify device information -- continued --

Word	Content	Description
69-79	0000H	Reserved
80	001EH	Major version number 15- 0(=1E) ATA-1, ATA-2, ATA-3 and ATA/ATAPI-4
81	0017H	Minor version number 15- 0(=17) ATA/ATAPI-4 T13 1153D revision 17
82	746BH	Command set supported 15(=0) Reserved 14(=1) 1=NOP command supported 13(=1) 1=READ BUFFER command supported 12(=1) 1=WRITE BUFFER command supported 11(=0) Reserved 10(=1) 1=Host Protected Area Feature Set supported 9(=0) 1=DEVICE RESET command supported 8(=0) 1=SERVICE interrupt supported 7(=0) 1=release interrupt supported 6(=1) 1=look-ahead supported 5(=1) 1=write cache supported 4(=0) 1=supports PACKET Command Feature Set 3(=1) 1=supports Power Management Feature Set 2(=0) 1=supports Removable Media Feature Set 1(=1) 1=supports Security Feature Set 0(=1) 1=supports S.M.A.R.T Feature Set
83	4088H	Command set supported 15(=0) Always 14(=1) Always 13- 8(=0) Reserved 7(=1) 1=Address Offset Feature supported 6- 5(=0) Reserved 4(=0) 1=Removable Media Status Notification Feature Set supported 3(=1) 1=Advanced Power Management Feature Set supported 2(=0) 1=CFA Feature Set supported 1(=0) 1=READ/WRITE DMA QUEUED supported 0(=0) 1=DOWNLOAD MICROCODE command supported
84	4000H	Command set/feature supported extension 15(=0) Always 14(=1) Always 13- 0(=0) Reserved

Figure 68. Identify device information -- continued --

Word	Content	Description
85	74XXH	Command set/feature enabled 15(=0) Reserved 14(=1) 1=NOP command supported 13(=1) 1=READ BUFFER command supported 12(=1) 1=WRITE BUFFER command supported 11(=0) Reserved 10(=1) 1=Host Protected Area Feature Set supported 9(=0) 1=DEVICE RESET command supported 8(=0) 1=SERVICE interrupt enabled 7(=0) 1=release interrupt enabled 6(=X) 1=look-ahead enabled 5(=X) 1=write cache enabled 4(=0) 1=supports PACKET Command Feature Set 3(=X) 1=supports Power Management Feature Set 2(=0) 1=supports Removable Media Feature Set 1(=X) 1=Security Feature Set enabled 0(=X) 1=S.M.A.R.T Feature Set enabled
86	00XXH	Command set/feature enabled 15- 8(=0) Reserved 7(=X) 1=Address Offset mode enabled 6- 5(=0) Reserved 4(=0) 1=Removable Media Status Notification Feature Set enabled 3(=X) 1=Advanced Poser Management Feature Set enabled 2(=0) 1=CFA Feature Set supported 1(=0) 1=READ/WRITE DMA QUEUED command supported 0(=0) 1=DOWNLOAD MICROCODE command supported
87	4000H	Command set/feature enabled 15(=0) Always 14(=1) Always 13- 0(=0) Reserved
88	0X07H	Ultra DMA Transfer mode (mode 2 supported) 15-11(=0) Reserved 10(=X) 1=UltraDMA mode 2 is selected 9(=X) 1=UltraDMA mode 1 is selected 8(=X) 1=UltraDMA mode 0 is selected 7- 3(=0) Reserved 2(=1) 1=UltraDMA mode 2 is supported 1(=1) 1=UltraDMA mode 1 is supported 0(=1) 1=UltraDMA mode 0 is supported
89	XXXXH	Time required for security erase unit completion Time= value(XXXXh)*2 [minutes] Refer to 12.21,]Security Erase Unit (F4h)≠ on page 132
90	0000H	Time required for Enhanced security erase completion 0000 : Not supported
91	00XXH	Current Advanced Power Management level 15- 8(=0) Reserved 7- 0(=X) Current Advanced Power Management level set by Set Features Command (01h to FEh)

Figure 69. Identify device information -- continued --

Word	Content	Description
92	XXXXH	Current Master Password Revision Codes
93-127	0000H	Reserved
128	0XXXH	Security Mode Feature. Bit assignments 15-9(=0) Reserved 8(=X) Security Level 1= Maximum, 0= High 7-6(=0) Reserved 5(=0) 1=Enhanced security erase supported 4(=X) 1=Security count expired 3(=X) 1=Security Frozen 2(=X) 1=Security locked 1(=X) 1=Security enabled 0(=X) 1=Security supported
129	000XH *	Current Set Feature Option. Bit assignments 15-4(=0) Reserved 3(=X) 1=Auto reassign enabled 2(=X) 1=Reverting enabled 1(=X) 1=Read Look-ahead enabled 0(=X) 1=Write Cache enabled
130	XXXXH *	Reserved
131	000XH *	Initial Power Mode Selection. Bit assignments 15-2(=0) Reserved 1(=1) Always 0(=X) Initial Power Mode 1= Standby, 0= Idle
132-255	0000H	Reserved

Figure 70. Identify device information

Notes:

1. The '*' mark in 'Content' field indicates the use of those parameters that are vendor specific.
2. The drive parameters are as follows.

Microcode revision	CXx0Axxx
DCXA-210000	
Number of cylinders	3FFFh
Number of heads	0010h
Model number (ASCII)	IBM-DCXA-210000
Total number of user addressable sectors	12BB230h
DCXA-208100	
Number of cylinders	3E08h
Number of heads	0010h
Model number (ASCII)	IBM-DCXA-208100
Total number of user addressable sectors	F43F80h

Figure 71. Number of cylinders/heads/sectors by models for DCXA-2xxxxx.

12.7 Identify Device DMA (EEh)

Command Block Output Registers								
Register	7	6	5	4	3	2	1	0
Data	-	-	-	-	-	-	-	-
Feature	-	-	-	-	-	-	-	-
Sector Count	-	-	-	-	-	-	-	-
Sector Number	-	-	-	-	-	-	-	-
Cylinder Low	-	-	-	-	-	-	-	-
Cylinder High	-	-	-	-	-	-	-	-
Device/Head	1	-	1	D	-	-	-	-
Command	1	1	1	0	1	1	1	0

Command Block Input Registers								
Register	7	6	5	4	3	2	1	0
Data	-	-	-	-	-	-	-	-
Error	...See Below...							
Sector Count	-	-	-	-	-	-	-	-
Sector Number	-	-	-	-	-	-	-	-
Cylinder Low	-	-	-	-	-	-	-	-
Cylinder High	-	-	-	-	-	-	-	-
Device/Head	-	-	-	-	-	-	-	-
Status	...See Below...							

Error Register							
7	6	5	4	3	2	1	0
CRC	UNC	0	IDN	0	ABT	T0N	AMN
0	0	0	0	0	V	0	0

Status Register							
7	6	5	4	3	2	1	0
BSY	RDY	DF	DSC	DRQ	COR	IDX	ERR
0	V	0	-	-	0	-	V

Figure 72. Identify Device Command DMA (EEh)

The Identify Device DMA command requests the device to transfer configuration information to the host. The device will transfer the same 256 words of device identification data by the Identify Device command(ECh) via DMA channel.

12.8 Idle (E3h/97h)

Command Block Output Registers								
Register	7	6	5	4	3	2	1	0
Data	-	-	-	-	-	-	-	-
Feature	-	-	-	-	-	-	-	-
Sector Count	V	V	V	V	V	V	V	V
Sector Number	-	-	-	-	-	-	-	-
Cylinder Low	-	-	-	-	-	-	-	-
Cylinder High	-	-	-	-	-	-	-	-
Device/Head	1	-	1	D	-	-	-	-
Command	1	1	1	0	0	0	1	1

Command Block Input Registers								
Register	7	6	5	4	3	2	1	0
Data	-	-	-	-	-	-	-	-
Error	...See Below...							
Sector Count	-	-	-	-	-	-	-	-
Sector Number	-	-	-	-	-	-	-	-
Cylinder Low	-	-	-	-	-	-	-	-
Cylinder High	-	-	-	-	-	-	-	-
Device/Head	-	-	-	-	-	-	-	-
Status	...See Below...							

Error Register							
7	6	5	4	3	2	1	0
CRC	UNC	0	IDN	0	ABT	T0N	AMN
0	0	0	0	0	V	0	0

Status Register							
7	6	5	4	3	2	1	0
BSY	RDY	DF	DSC	DRQ	COR	IDX	ERR
0	V	0	V	-	0	-	V

Figure 73. Idle Command (E3h/97h)

The Idle command causes the device to enter Idle mode immediately, and set auto power down timeout parameter(standby timer). And then the timer starts counting down.

When the Idle mode is entered, the device is spun up to operating speed. If the device is already spinning, the spin up sequence is not executed.

During Idle mode the device is spinning and ready to respond to host commands immediately.

Output Parameters To The Device

Sector Count Timeout Parameter. If zero, the timeout interval(Standby Timer) is NOT disabled, but the timeout interval is set for 109 minutes automatically. If other than zero, the timeout interval is set for (Timeout Parameter × 5) seconds.

The device will enter Standby mode automatically if the timeout interval expires with no device access from the host. The timeout interval will be reinitialized if there is a device access before the timeout interval expires.

12.9 Idle Immediate (E1h/95h)

Command Block Output Registers								
Register	7	6	5	4	3	2	1	0
Data	-	-	-	-	-	-	-	-
Feature	-	-	-	-	-	-	-	-
Sector Count	-	-	-	-	-	-	-	-
Sector Number	-	-	-	-	-	-	-	-
Cylinder Low	-	-	-	-	-	-	-	-
Cylinder High	-	-	-	-	-	-	-	-
Device/Head	1	-	1	D	-	-	-	-
Command	1	1	1	0	0	0	0	1

Command Block Input Registers								
Register	7	6	5	4	3	2	1	0
Data	-	-	-	-	-	-	-	-
Error	...See Below...							
Sector Count	-	-	-	-	-	-	-	-
Sector Number	-	-	-	-	-	-	-	-
Cylinder Low	-	-	-	-	-	-	-	-
Cylinder High	-	-	-	-	-	-	-	-
Device/Head	-	-	-	-	-	-	-	-
Status	...See Below...							

Error Register							
7	6	5	4	3	2	1	0
CRC	UNC	0	IDN	0	ABT	T0N	AMN
0	0	0	0	0	V	0	0

Status Register							
7	6	5	4	3	2	1	0
BSY	RDY	DF	DSC	DRQ	COR	IDX	ERR
0	V	0	V	-	0	-	V

Figure 74. Idle Immediate Command (E1h/95h)

The Idle Immediate command causes the device to enter Idle mode.

The device is spun up to operating speed. If the device is already spinning, the spin up sequence is not executed.

During Idle mode the device is spinning and ready to respond to host commands immediately.

The Idle Immediate command will not affect the auto power down timeout parameter.

12.10 Initialize Device Parameters (91h)

Command Block Output Registers								
Register	7	6	5	4	3	2	1	0
Data	-	-	-	-	-	-	-	-
Feature	-	-	-	-	-	-	-	-
Sector Count	V	V	V	V	V	V	V	V
Sector Number	-	-	-	-	-	-	-	-
Cylinder Low	-	-	-	-	-	-	-	-
Cylinder High	-	-	-	-	-	-	-	-
Device/Head	1	-	1	D	H	H	H	H
Command	1	0	0	1	0	0	0	1

Command Block Input Registers								
Register	7	6	5	4	3	2	1	0
Data	-	-	-	-	-	-	-	-
Error	-	-	-	-	-	-	-	-
Sector Count	-	-	-	-	-	-	-	-
Sector Number	-	-	-	-	-	-	-	-
Cylinder Low	-	-	-	-	-	-	-	-
Cylinder High	-	-	-	-	-	-	-	-
Device/Head	-	-	-	-	-	-	-	-
Status	...See Below...							

Error Register							
7	6	5	4	3	2	1	0
CRC	UNC	0	IDN	0	ABT	T0N	AMN
0	0	0	0	0	V	0	0

Status Register							
7	6	5	4	3	2	1	0
BSY	RDY	DF	DSC	DRQ	COR	IDX	ERR
0	0	0	-	-	0	-	V

Figure 75. Initialize Device Parameters Command (91h)

The Initialize Device Parameters command enables the host to set the number of sectors per track and the number of heads minus 1, per cylinder. Words 54-58 in Identify Device Information reflects these parameters.

The parameters remain in effect until the following events:

- Another Initialize Device Parameters command is received.
- The device is powered off.
- Hard reset occurs.
- Soft reset occurs and the Set Feature option of CCh is set instead of 66h.

Output Parameters To The Device

Sector Count The number of sectors per track. 0 does not mean there are 256 sectors per track, but there is no sector per track.

H The number of heads minus 1 per cylinder. The minimum is 0 and the maximum is 15.

Note: The following condition needs to be satisfied to avoid invalid number of cylinder beyond FFFFh, which will cause performance degradation of the drive.

$$(\text{Total customer usable data sectors}) / ((\text{Sector Count}) * (\text{H} + 1)) \rightarrow \text{FFFFh}$$

The total customer usable data sectors are indicated at 3.1, “Logical Drive Format” on page 9, and related description is at 10.3.1, “Logical CHS Addressing Mode” on page 69.

12.11 Read Buffer (E4h)

Command Block Output Registers								
Register	7	6	5	4	3	2	1	0
Data	-	-	-	-	-	-	-	-
Feature	-	-	-	-	-	-	-	-
Sector Count	-	-	-	-	-	-	-	-
Sector Number	-	-	-	-	-	-	-	-
Cylinder Low	-	-	-	-	-	-	-	-
Cylinder High	-	-	-	-	-	-	-	-
Device/Head	1	-	1	D	-	-	-	-
Command	1	1	1	0	0	1	0	0

Command Block Input Registers								
Register	7	6	5	4	3	2	1	0
Data	-	-	-	-	-	-	-	-
Error	...See Below...							
Sector Count	-	-	-	-	-	-	-	-
Sector Number	-	-	-	-	-	-	-	-
Cylinder Low	-	-	-	-	-	-	-	-
Cylinder High	-	-	-	-	-	-	-	-
Device/Head	-	-	-	-	-	-	-	-
Status	...See Below...							

Error Register							
7	6	5	4	3	2	1	0
CRC	UNC	0	IDN	0	ABT	T0N	AMN
0	0	0	0	0	V	0	0

Status Register							
7	6	5	4	3	2	1	0
BSY	RDY	DF	DSC	DRQ	COR	IDX	ERR
0	V	0	-	-	0	-	V

Figure 76. Read Buffer Command (E4h)

The Read Buffer command transfers a sector of data from the sector buffer of device to the host.

The sector is transferred through the Data Register 16 bits at a time.

The sector transferred will be from the same part of the buffer written to by the last Write Buffer command. The contents of the sector may be different if any reads or writes have occurred since the Write Buffer command was issued.

12.12 Read DMA (C8h/C9h)

Command Block Output Registers								
Register	7	6	5	4	3	2	1	0
Data	-	-	-	-	-	-	-	-
Feature	-	-	-	-	-	-	-	-
Sector Count	V	V	V	V	V	V	V	V
Sector Number	V	V	V	V	V	V	V	V
Cylinder Low	V	V	V	V	V	V	V	V
Cylinder High	V	V	V	V	V	V	V	V
Device/Head	1	L	1	D	H	H	H	H
Command	1	1	0	0	1	0	0	R

Command Block Input Registers								
Register	7	6	5	4	3	2	1	0
Data	-	-	-	-	-	-	-	-
Error	...See Below...							
Sector Count	V	V	V	V	V	V	V	V
Sector Number	V	V	V	V	V	V	V	V
Cylinder Low	V	V	V	V	V	V	V	V
Cylinder High	V	V	V	V	V	V	V	V
Device/Head	-	-	-	-	H	H	H	H
Status	...See Below...							

Error Register							
7	6	5	4	3	2	1	0
CRC	UNC	0	IDN	0	ABT	T0N	AMN
V	V	0	V	0	V	0	V

Status Register							
7	6	5	4	3	2	1	0
BSY	RDY	DF	DSC	DRQ	COR	IDX	ERR
0	V	0	V	-	0	-	V

Figure 77. Read DMA Command (C8h/C9h)

The Read DMA command reads one or more sectors of data from disk media, then transfers the data from the device to the host.

The sectors are transferred through the Data Register 16 bits at a time.

The host initializes a slave-DMA channel prior to issuing the command. The data transfers are qualified by DMARQ and are performed by the slave-DMA channel. The device issues only one interrupt per command to indicate that data transfer has terminated and status is available.

If an uncorrectable error occurs, the read will be terminated at the failing sector.

Output Parameters To The Device

- Sector Count** The number of continuous sectors to be transferred. If zero is specified, then 256 sectors will be transferred.
- Sector Number** The sector number of the first sector to be transferred. (L=0)
In LBA mode, this register specifies LBA address bits 0 - 7 to be transferred. (L=1)
- Cylinder High/Low** The cylinder number of the first sector to be transferred. (L=0)
In LBA mode, this register specifies LBA address bits 8 - 15 (Low) 16 - 23 (High) to be transferred. (L=1)

- H** The head number of the first sector to be transferred. (L=0)
In LBA mode, this register specifies LBA bits 24-27 to be transferred. (L=1)
- R** The retry bit. If set to one, then retries are disabled.

Input Parameters From The Device

- Sector Count** The number of requested sectors not transferred. This will be zero, unless an unrecoverable error occurs.
- Sector Number** The sector number of the last transferred sector. (L=0)
In LBA mode, this register contains current LBA bits 0 - 7. (L=1)
- Cylinder High/Low** The cylinder number of the last transferred sector. (L=0)
In LBA mode, this register contains current LBA bits 8 - 15 (Low), 16 - 23 (High). (L=1)
- H** The head number of the sector to be transferred. (L=0)
In LBA mode, this register contains current LBA bits 24 - 27. (L=1)

12.13 Read Long (22h/23h)

Command Block Output Registers								
Register	7	6	5	4	3	2	1	0
Data	-	-	-	-	-	-	-	-
Feature	-	-	-	-	-	-	-	-
Sector Count	0	0	0	0	0	0	0	1
Sector Number	V	V	V	V	V	V	V	V
Cylinder Low	V	V	V	V	V	V	V	V
Cylinder High	V	V	V	V	V	V	V	V
Device/Head	1	L	1	D	H	H	H	H
Command	0	0	1	0	0	0	1	R

Command Block Input Registers								
Register	7	6	5	4	3	2	1	0
Data	-	-	-	-	-	-	-	-
Error	...See Below...							
Sector Count	-	-	-	-	-	-	-	V
Sector Number	V	V	V	V	V	V	V	V
Cylinder Low	V	V	V	V	V	V	V	V
Cylinder High	V	V	V	V	V	V	V	V
Device/Head	-	-	-	-	H	H	H	H
Status	...See Below...							

Error Register							
7	6	5	4	3	2	1	0
CRC	UNC	0	IDN	0	ABT	T0N	AMN
0	0	0	V	0	V	0	V

Status Register							
7	6	5	4	3	2	1	0
BSY	RDY	DF	DSC	DRQ	COR	IDX	ERR
0	V	0	V	-	0	-	V

Figure 78. Read Long Command (22h/23h)

The Read Long command reads the designated one sector of data and the ECC bytes from the disk media, then transfers the data and ECC bytes from the device to the host.

After 512 bytes of data have been transferred, the device will keep setting DRQ=1 to indicate that the device is ready to transfer the ECC bytes to the host. The data is transferred 16 bits at a time, and the ECC bytes are transferred 8 bits at a time. The number of ECC bytes are 4 or 34 according to the setting of Set Feature option. The default setting is 4 bytes of ECC data.

The command makes a single attempt to read the data and does not check the data using ECC. Whatever is read is returned to the host.

Output Parameters To The Device

Sector Count The number of continuous sectors to be transferred. The Sector Count must be set to one.

Sector Number The sector number of the sector to be transferred. (L=0)
In LBA mode, this register contains LBA bits 0 - 7. (L=1)

Cylinder High/Low The cylinder number of the sector to be transferred. (L=0)
In LBA mode, this register contains LBA bits 8 - 15 (Low), 16 - 23 (High). (L=1)

- H** The head number of the sector to be transferred. (L=0)
In LBA mode, this register contains LBA bits 24-27. (L=1)
- R** The retry bit. If set to one, then retries are disabled.

Input Parameters From The Device

- Sector Count** The number of requested sectors not transferred.
- Sector Number** The sector number of the transferred sector. (L=0)
In LBA mode, this register contains current LBA bits 0 - 7. (L=1)
- Cylinder High/Low** The cylinder number of the transferred sector. (L=0)
In LBA mode, this register contains current LBA bits 8 - 15 (Low), 16 - 23 (High). (L=1)
- H** The head number of the transferred sector. (L=0)
In LBA mode, this register contains current LBA bits 24-27. (L=1)

It should be noted that the device internally uses 34 bytes of ECC data on all data written or read from the disk. The 4 byte mode of operation is provided via an emulation. It is recommended that for testing the effectiveness and integrity of the devices ECC functions that the 34 byte ECC mode should be used.

12.14 Read Multiple (C4h)

Command Block Output Registers								
Register	7	6	5	4	3	2	1	0
Data	-	-	-	-	-	-	-	-
Feature	-	-	-	-	-	-	-	-
Sector Count	V	V	V	V	V	V	V	V
Sector Number	V	V	V	V	V	V	V	V
Cylinder Low	V	V	V	V	V	V	V	V
Cylinder High	V	V	V	V	V	V	V	V
Device/Head	1	L	1	D	H	H	H	H
Command	1	1	0	0	0	1	0	0

Command Block Input Registers								
Register	7	6	5	4	3	2	1	0
Data	-	-	-	-	-	-	-	-
Error	...See Below...							
Sector Count	V	V	V	V	V	V	V	V
Sector Number	V	V	V	V	V	V	V	V
Cylinder Low	V	V	V	V	V	V	V	V
Cylinder High	V	V	V	V	V	V	V	V
Device/Head	-	-	-	-	H	H	H	H
Status	...See Below...							

Error Register							
7	6	5	4	3	2	1	0
CRC	UNC	0	IDN	0	ABT	T0N	AMN
0	V	0	V	0	V	0	V

Status Register							
7	6	5	4	3	2	1	0
BSY	RDY	DF	DSC	DRQ	COR	IDX	ERR
0	V	0	V	-	0	-	V

Figure 79. Read Multiple Command (C4h)

The Read Multiple command reads one or more sectors of data from disk media, then transfers the data from the device to the host.

The sectors are transferred through the Data Register 16 bits at a time. Command execution is identical to the Read Sectors command except that an interrupt is generated for each block (as defined by the Set Multiple command) instead of for each sector.

Output Parameters To The Device

- Sector Count** The number of continuous sectors to be transferred. If zero is specified, then 256 sectors will be transferred.
- Sector Number** The sector number of the first sector to be transferred. (L=0)
In LBA mode, this register contains LBA bits 0 - 7. (L=1)
- Cylinder High/Low** The cylinder number of the first sector to be transferred. (L=0)
In LBA mode, this register contains LBA bits 8 - 15 (Low), 16 - 23 (High). (L=1)
- H** The head number of the first sector to be transferred. (L=0)
In LBA mode, this register contains LBA bits 24 - 27. (L=1)

Input Parameters From The Device

Sector Count	The number of requested sectors not transferred. This will be zero, unless an unrecoverable error occurs.
Sector Number	The sector number of the last transferred sector. (L=0) In LBA mode, this register contains current LBA bits 0 - 7. (L=1)
Cylinder High/Low	The cylinder number of the last transferred sector. (L=0) In LBA mode, this register contains current LBA bits 8 - 15 (Low), 16 - 23 (High). (L=1)
H	The head number of the last transferred sector. (L=0) In LBA mode, this register contains current LBA bits 24 - 27. (L=1)

12.15 Read Native Max Address (F8h)

Command Block Output Registers							
Register	7	6	5	4	3	2	1 0
Data	-	-	-	-	-	-	-
Feature	-	-	-	-	-	-	-
Sector Count	-	-	-	-	-	-	-
Sector Number	-	-	-	-	-	-	-
Cylinder Low	-	-	-	-	-	-	-
Cylinder High	-	-	-	-	-	-	-
Device/Head	1	L	1	D	-	-	-
Command	1	1	1	1	1	0	0 0

Command Block Input Registers							
Register	7	6	5	4	3	2	1 0
Data	-	-	-	-	-	-	-
Error	...See Below...						
Sector Count	-	-	-	-	-	-	-
Sector Number	V	V	V	V	V	V	V
Cylinder Low	V	V	V	V	V	V	V
Cylinder High	V	V	V	V	V	V	V
Device/Head	-	-	-	-	H	H	H
Status	...See Below...						

Error Register							
7	6	5	4	3	2	1	0
CRC	UNC	0	IDN	0	ABT	T0N	AMN
0	0	0	0	0	V	0	0

Status Register							
7	6	5	4	3	2	1	0
BSY	RDY	DF	DSC	DRQ	COR	IDX	ERR
0	V	0	-	-	0	-	V

Figure 80. Read Native Max Address (F8h)

This command returns the native max LBA/CYL of HDD which is not effected by Set Max ADDRESS command. Even if the Address Offset mode is enabled, the native max LBA/CYL oh HDD is returned.

Output Parameters To The Device

- L** LBA mode. Indicates the addressing mode. L=0 specifies CHS mode and L=1 does LBA addressing mode.
- D** The device number bit. Indicates that the device number bit of the Device/Head Register should be specified. D=0 selects the master device and D=1 selects the slave device.
- Indicates that the bit is not used.

Input Parameters From The Device

- Sector Number** In LBA mode, this register contains native max LBA bits 0 - 7. (L=1)
In CHS mode, this register contains native max sector number. (L=0)
- Cylinder High/Low** In LBA mode, this register contains native max LBA bits 8 - 15 (Low), 16 - 23 (High). (L=1)
In CHS mode, this register contains native max cylinder number. (L=0)
- H** In LBA mode, this register contains native max LBA bits 24 - 27. (L=1)
In CHS mode, this register contains native max head number. (L=0)

- V** Valid. Indicates that the bit is part of an input parameter and will be set to 0 or 1 by the device.
- Indicates that the bit is not used.

12.16 Read Sectors (20h/21h)

Command Block Output Registers								
Register	7	6	5	4	3	2	1	0
Data	-	-	-	-	-	-	-	-
Feature	-	-	-	-	-	-	-	-
Sector Count	V	V	V	V	V	V	V	V
Sector Number	V	V	V	V	V	V	V	V
Cylinder Low	V	V	V	V	V	V	V	V
Cylinder High	V	V	V	V	V	V	V	V
Device/Head	1	L	1	D	H	H	H	H
Command	0	0	1	0	0	0	0	R

Command Block Input Registers								
Register	7	6	5	4	3	2	1	0
Data	-	-	-	-	-	-	-	-
Error	...See Below...							
Sector Count	V	V	V	V	V	V	V	V
Sector Number	V	V	V	V	V	V	V	V
Cylinder Low	V	V	V	V	V	V	V	V
Cylinder High	V	V	V	V	V	V	V	V
Device/Head	-	-	-	-	H	H	H	H
Status	...See Below...							

Error Register							
7	6	5	4	3	2	1	0
CRC	UNC	0	IDN	0	ABT	T0N	AMN
0	V	0	V	0	V	0	V

Status Register							
7	6	5	4	3	2	1	0
BSY	RDY	DF	DSC	DRQ	COR	IDX	ERR
0	V	0	V	-	0	-	V

Figure 81. Read Sectors Command (20h/21h)

The Read Sectors command reads one or more sectors of data from disk media, then transfers the data from the device to the host.

The sectors are transferred through the Data Register 16 bits at a time.

If an uncorrectable error occurs, the read will be terminated at the failing sector.

Output Parameters To The Device

Sector Count The number of continuous sectors to be transferred. If zero is specified, then 256 sectors will be transferred.

Sector Number The sector number of the first sector to be transferred. (L=0)

In LBA mode, this register contains LBA bits 0 - 7. (L=1)

Cylinder High/Low The cylinder number of the first sector to be transferred. (L=0)

In LBA mode, this register contains LBA bits 8 - 15 (Low), 16 - 23 (High). (L=1)

H The head number of the first sector to be transferred. (L=0)

In LBA mode, this register contains LBA bits 24 - 27. (L=1)

R The retry bit. If set to one, then retries are disabled.

Input Parameters From The Device

Sector Count	The number of requested sectors not transferred. This will be zero, unless an unrecoverable error occurs.
Sector Number	The sector number of the last transferred sector. (L=0) In LBA mode, this register contains current LBA bits 0 - 7. (L=1)
Cylinder High/Low	The cylinder number of the last transferred sector. (L=0) In LBA mode, this register contains current LBA bits 8 - 15 (Low), 16 - 23 (High). (L=1)
H	The head number of the last transferred sector. (L=0) In LBA mode, this register contains current LBA bits 24 - 27. (L=1)

12.17 Read Verify Sectors (40h/41h)

Command Block Output Registers								
Register	7	6	5	4	3	2	1	0
Data	-	-	-	-	-	-	-	-
Feature	-	-	-	-	-	-	-	-
Sector Count	V	V	V	V	V	V	V	V
Sector Number	V	V	V	V	V	V	V	V
Cylinder Low	V	V	V	V	V	V	V	V
Cylinder High	V	V	V	V	V	V	V	V
Device/Head	1	L	1	D	H	H	H	H
Command	0	0	1	0	0	0	0	R

Command Block Input Registers								
Register	7	6	5	4	3	2	1	0
Data	-	-	-	-	-	-	-	-
Error	...See Below...							
Sector Count	V	V	V	V	V	V	V	V
Sector Number	V	V	V	V	V	V	V	V
Cylinder Low	V	V	V	V	V	V	V	V
Cylinder High	V	V	V	V	V	V	V	V
Device/Head	-	-	-	-	H	H	H	H
Status	...See Below...							

Error Register							
7	6	5	4	3	2	1	0
CRC	UNC	0	IDN	0	ABT	T0N	AMN
0	V	0	V	0	V	0	V

Status Register							
7	6	5	4	3	2	1	0
BSY	RDY	DF	DSC	DRQ	COR	IDX	ERR
0	V	0	V	-	0	-	V

Figure 82. Read Verify Sectors Command (40h/41h)

The Read Verify Sectors verifies one or more sectors on the device. No data is transferred to the host.

The difference of Read Sectors command and Read Verify Sectors command is whether the data is transferred to the host or not.

If an uncorrectable error occurs, the read verify will be terminated at the failing sector.

Output Parameters To The Device

Sector Count The number of continuous sectors to be verified. If zero is specified, then 256 sectors will be verified.

Sector Number The sector number of the first sector to be transferred. (L=0)

In LBA mode, this register contains LBA bits 0 - 7. (L=1)

Cylinder High/Low The cylinder number of the first sector to be transferred. (L=0)

In LBA mode, this register contains LBA bits 8 - 15 (Low), 16 - 23 (High). (L=1)

H The head number of the first sector to be transferred. (L=0)

In LBA mode, this register contains LBA bits 24 - 27. (L=1)

R The retry bit. If set to one, then retries are disabled.

Input Parameters From The Device

Sector Count	The number of requested sectors not verified. This will be zero, unless an unrecoverable error occurs.
Sector Number	The sector number of the last transferred sector. (L=0) In LBA mode, this register contains current LBA bits 0 - 7. (L=1)
Cylinder High/Low	The cylinder number of the last transferred sector. (L=0) In LBA mode, this register contains current LBA bits 8 - 15 (Low), 16 - 23 (High). (L=1)
H	The head number of the last transferred sector. (L=0) In LBA mode, this register contains current LBA bits 24 - 27. (L=1)

12.18 Recalibrate (1xh)

Command Block Output Registers								
Register	7	6	5	4	3	2	1	0
Data	-	-	-	-	-	-	-	-
Feature	-	-	-	-	-	-	-	-
Sector Count	-	-	-	-	-	-	-	-
Sector Number	-	-	-	-	-	-	-	-
Cylinder Low	-	-	-	-	-	-	-	-
Cylinder High	-	-	-	-	-	-	-	-
Device/Head	1	-	1	D	-	-	-	-
Command	0	0	0	1	-	-	-	-

Command Block Input Registers								
Register	7	6	5	4	3	2	1	0
Data	-	-	-	-	-	-	-	-
Error	...See Below...							
Sector Count	-	-	-	-	-	-	-	-
Sector Number	-	-	-	-	-	-	-	-
Cylinder Low	-	-	-	-	-	-	-	-
Cylinder High	-	-	-	-	-	-	-	-
Device/Head	-	-	-	-	-	-	-	-
Status	...See Below...							

Error Register							
7	6	5	4	3	2	1	0
CRC	UNC	0	IDN	0	ABT	T0N	AMN
0	0	0	0	0	V	V	0

Status Register							
7	6	5	4	3	2	1	0
BSY	RDY	DF	DSC	DRQ	COR	IDX	ERR
0	V	0	V	-	0	-	V

Figure 83. Recalibrate Command (1xh)

The Recalibrate command moves the read/write heads from anywhere on the disk to cylinder 0.

If the device cannot reach cylinder 0, T0N (Track 0 Not Found) will be set in the Error Register.

12.19 Security Disable Password (F6h)

Command Block Output Registers								
Register	7	6	5	4	3	2	1	0
Data	-	-	-	-	-	-	-	-
Feature	-	-	-	-	-	-	-	-
Sector Count	-	-	-	-	-	-	-	-
Sector Number	-	-	-	-	-	-	-	-
Cylinder Low	-	-	-	-	-	-	-	-
Cylinder High	-	-	-	-	-	-	-	-
Device/Head	1	-	1	D	-	-	-	-
Command	1	1	1	1	0	1	1	0

Command Block Input Registers								
Register	7	6	5	4	3	2	1	0
Data	-	-	-	-	-	-	-	-
Error	...See Below...							
Sector Count	-	-	-	-	-	-	-	-
Sector Number	-	-	-	-	-	-	-	-
Cylinder Low	-	-	-	-	-	-	-	-
Cylinder High	-	-	-	-	-	-	-	-
Device/Head	-	-	-	-	-	-	-	-
Status	...See Below...							

Error Register							
7	6	5	4	3	2	1	0
CRC	UNC	0	IDN	0	ABT	T0N	AMN
0	0	0	0	0	V	0	0

Status Register							
7	6	5	4	3	2	1	0
BSY	RDY	DF	DSC	DRQ	COR	IDX	ERR
0	V	0	V	-	0	-	V

Figure 84. Security Disable Password Command (F6h)

The Security Disable Password command disables the security mode feature (device lock function).

The Security Disable Password command requests a transfer of a single sector of data from the host including information specified in Figure 85. Then the device checks the transferred password. If the User Password or Master Password matches the given password, the device disables the security mode feature (device lock function). This command does not change the Master Password which may be re-activated later by setting User Password. This command should be executed in device unlock mode.

Word	Description
00	Control word bit 0 : Identifier (1- Master, 0- User) bit 1-15 : Reserved
01-16	Password (32 bytes)
17-255	Reserved

Figure 85. Password Information for Security Disable Password command

The device will compare the password sent from this host with that specified in the control word.

Identifier Zero indicates that the device should check the supplied password against the user password stored internally. One indicates that the device should check the given password against the master password stored internally.

12.20 Security Erase Prepare (F3h)

Command Block Output Registers								
Register	7	6	5	4	3	2	1	0
Data	-	-	-	-	-	-	-	-
Feature	-	-	-	-	-	-	-	-
Sector Count	-	-	-	-	-	-	-	-
Sector Number	-	-	-	-	-	-	-	-
Cylinder Low	-	-	-	-	-	-	-	-
Cylinder High	-	-	-	-	-	-	-	-
Device/Head	1	-	1	D	-	-	-	-
Command	1	1	1	1	0	0	1	1

Command Block Input Registers								
Register	7	6	5	4	3	2	1	0
Data	-	-	-	-	-	-	-	-
Error	...See Below...							
Sector Count	-	-	-	-	-	-	-	-
Sector Number	-	-	-	-	-	-	-	-
Cylinder Low	-	-	-	-	-	-	-	-
Cylinder High	-	-	-	-	-	-	-	-
Device/Head	-	-	-	-	-	-	-	-
Status	...See Below...							

Error Register							
7	6	5	4	3	2	1	0
CRC	UNC	0	IDN	0	ABT	T0N	AMN
0	0	0	0	0	V	0	0

Status Register							
7	6	5	4	3	2	1	0
BSY	RDY	DF	DSC	DRQ	COR	IDX	ERR
0	V	0	V	-	0	-	V

Figure 86. Security Erase Prepare Command (F3h)

The Security Erase Prepare Command must be issued immediately before the Security Erase Unit Command to enable device erasing and unlocking.

The Security Erase Prepare Command must be issued immediately before the Format Unit Command. This command is to prevent accidental erasure of the device.

This command does not request to transfer data.

The execution time of this command is shown below.

DCXA-210000	about 22 min
DCXA-208100	about 19 min

12.21 Security Erase Unit (F4h)

Command Block Output Registers								
Register	7	6	5	4	3	2	1	0
Data	-	-	-	-	-	-	-	-
Feature	-	-	-	-	-	-	-	-
Sector Count	-	-	-	-	-	-	-	-
Sector Number	-	-	-	-	-	-	-	-
Cylinder Low	-	-	-	-	-	-	-	-
Cylinder High	-	-	-	-	-	-	-	-
Device/Head	1	-	1	D	-	-	-	-
Command	1	1	1	1	0	1	0	0

Command Block Input Registers								
Register	7	6	5	4	3	2	1	0
Data	-	-	-	-	-	-	-	-
Error	...See Below...							
Sector Count	-	-	-	-	-	-	-	-
Sector Number	-	-	-	-	-	-	-	-
Cylinder Low	-	-	-	-	-	-	-	-
Cylinder High	-	-	-	-	-	-	-	-
Device/Head	-	-	-	-	-	-	-	-
Status	...See Below...							

Error Register							
7	6	5	4	3	2	1	0
CRC	UNC	0	IDN	0	ABT	T0N	AMN
0	0	0	V	0	V	0	0

Status Register							
7	6	5	4	3	2	1	0
BSY	RDY	DF	DSC	DRQ	COR	IDX	ERR
0	V	0	V	-	0	-	V

Figure 87. Security Erase Unit Command (F4h)

The Security Erase Unit command initializes all user data sectors, then disables the device lock function.

Note that the Security Erase Unit command initializes from LBA 0 to Native MAX LBA. Host MAX LBA set by Initialize Drive Parameter or Set Max Address command is ignored. So the protected area by Set Max Address command is also initialized.

This command requests to transfer a single sector data from the host including information specified in Figure 88.

If the password does not match then the device rejects the command with an Aborted error.

Word	Description
00	Control word bit 0 : Identifier (1- Master, 0- User) bit 1-15 : Reserved
01-16	Password (32 bytes)
17-255	Reserved

Figure 88. Erase Unit information

Identifier Zero indicates that the device should check the supplied password against the user password stored internally. One indicates that the device should check the given password against the master password stored internally.

The Security Erase Unit command erases all user data and disables the security mode feature (device lock function). So after completing this command, all user data will be initialized to zero with write operation. At this time, it is not verified with read operation whether the sector of data is initialized correctly. Also, the defective sector information and the reassigned sector information for the device are not updated. The security erase prepare command should be completed immediately prior to the Security Erase Unit command. If the device receives a Security Erase Unit command without a prior Security Erase Prepare command the device aborts the security erase unit command.

This command disables the security mode feature (device lock function), however the master password is still stored internally within the device and may be re-activated later when a new user password is set. If you execute this command on disabling the security mode feature (device lock function), the password sent by the host is NOT compared with the password stored in the device for both the Master Password and the User Password, and then the device only erases all user data.

The execution time of this command is shown below.

DCXA-210000 about 22 min

DCXA-208100 about 19 min

12.22 Security Freeze Lock (F5h)

Command Block Output Registers								
Register	7	6	5	4	3	2	1	0
Data	-	-	-	-	-	-	-	-
Feature	-	-	-	-	-	-	-	-
Sector Count	-	-	-	-	-	-	-	-
Sector Number	-	-	-	-	-	-	-	-
Cylinder Low	-	-	-	-	-	-	-	-
Cylinder High	-	-	-	-	-	-	-	-
Device/Head	1	-	1	D	-	-	-	-
Command	1	1	1	1	0	1	0	1

Command Block Input Registers								
Register	7	6	5	4	3	2	1	0
Data	-	-	-	-	-	-	-	-
Error	...See Below...							
Sector Count	-	-	-	-	-	-	-	-
Sector Number	-	-	-	-	-	-	-	-
Cylinder Low	-	-	-	-	-	-	-	-
Cylinder High	-	-	-	-	-	-	-	-
Device/Head	-	-	-	-	-	-	-	-
Status	...See Below...							

Error Register							
7	6	5	4	3	2	1	0
CRC	UNC	0	IDN	0	ABT	T0N	AMN
0	0	0	0	0	V	0	0

Status Register							
7	6	5	4	3	2	1	0
BSY	RDY	DF	DSC	DRQ	COR	IDX	ERR
0	V	0	-	-	0	-	V

Figure 89. Security Freeze Lock Command (F5h)

The Security Freeze Lock Command allows the device to enter frozen mode immediately.

After this command is completed, the command which updates Security Mode Feature (Device Lock Function) is rejected.

Frozen mode is quit only by Power off or Hard Reset.

The following commands are rejected when the device is in frozen mode. For detail, refer to Figure 53 on page 80.

- Security Set Password
- Security Unlock
- Security Disable Password
- Security Erase Unit

12.23 Security Set Password (F1h)

Command Block Output Registers								
Register	7	6	5	4	3	2	1	0
Data	-	-	-	-	-	-	-	-
Feature	-	-	-	-	-	-	-	-
Sector Count	-	-	-	-	-	-	-	-
Sector Number	-	-	-	-	-	-	-	-
Cylinder Low	-	-	-	-	-	-	-	-
Cylinder High	-	-	-	-	-	-	-	-
Device/Head	1	-	1	D	-	-	-	-
Command	1	1	1	1	0	0	0	1

Command Block Input Registers								
Register	7	6	5	4	3	2	1	0
Data	-	-	-	-	-	-	-	-
Error	...See Below...							
Sector Count	-	-	-	-	-	-	-	-
Sector Number	-	-	-	-	-	-	-	-
Cylinder Low	-	-	-	-	-	-	-	-
Cylinder High	-	-	-	-	-	-	-	-
Device/Head	-	-	-	-	-	-	-	-
Status	...See Below...							

Error Register							
7	6	5	4	3	2	1	0
CRC	UNC	0	IDN	0	ABT	T0N	AMN
0	0	0	0	0	V	0	0

Status Register							
7	6	5	4	3	2	1	0
BSY	RDY	DF	DSC	DRQ	COR	IDX	ERR
0	V	0	-	-	0	-	V

Figure 90. Security Set Password Command (F1h)

The Security Set Password command enables security mode feature (device lock function), and sets the master password or the user password.

The security mode feature (device lock function) is enabled by this command, and the device is not locked immediately. The device is locked after next power on reset or hard reset. When the MASTER password is set by this command, the master password is registered internally, but the device is NOT locked after next power on reset or hard reset.

This command requests a transfer of a single sector of data from the host including the information specified in Figure 91 on page 136.

The data transferred controls the function of this command.

Word	Description
00	Control word bit 0 : Identifier (1- Master, 0- User) bit 1-7 : Reserved bit 8 : Security level (1- Maximum, 0- High) bit 9-15 : Reserved
01-16	Password (32 byte)
17-18	Master Password Revision Code (valid if Word 0 bit 0 = 1)
19-255	Reserved

Figure 91. Security Set Password Information

Identifier Zero indicates that device regards Password as User Password. One indicates that device regards Password as Master Password.

Security Level Zero indicates High level, one indicates Maximum level. If the host sets High level and the password is forgotten, then the Master Password can be used to unlock the device. If the host sets Maximum level and the user password is forgotten, only an Security Erase Prepare/Security Unit command can unlock the device and all data will be lost.

Password The text of the password - all 32 bytes are always significant.

Master Password Revision Code The Revision Code field is set with Master password. If Identifier is User, the Revision Code is not set. The Revision Code field is returned in Identify Device word 92. The valid Revision Codes are 0000h to FFFDh. Default Master Password Revision Code is FFFEh. FFFFh is reserved.

The setting of the Identifier and Security level bits interact as follows.

Identifier=User / Security level = High The password supplied with the command will be saved as the new user password. The security mode feature (lock function) will be enabled from the next power on. The file may then be unlocked by either the user password or the previously set master password.

Identifier=Master / Security level = High This combination will set a master password but will NOT enable the security mode feature (lock function).

Identifier=User / Security level = Maximum The password supplied with the command will be saved as the new user password. The security mode feature (lock function) will be enabled from the next power on. The file may then be unlocked by only the user password. The master password previously set is still stored in the file but may NOT be used to unlock the device.

Identifier=Master / Security level = Maximum This combination will set a master password but will NOT enable the security mode feature (lock function).

12.24 Security Unlock (F2h)

Command Block Output Registers								
Register	7	6	5	4	3	2	1	0
Data	-	-	-	-	-	-	-	-
Feature	-	-	-	-	-	-	-	-
Sector Count	-	-	-	-	-	-	-	-
Sector Number	-	-	-	-	-	-	-	-
Cylinder Low	-	-	-	-	-	-	-	-
Cylinder High	-	-	-	-	-	-	-	-
Device/Head	1	-	1	D	-	-	-	-
Command	1	1	1	1	0	0	1	0

Command Block Input Registers								
Register	7	6	5	4	3	2	1	0
Data	-	-	-	-	-	-	-	-
Error	...See Below...							
Sector Count	-	-	-	-	-	-	-	-
Sector Number	-	-	-	-	-	-	-	-
Cylinder Low	-	-	-	-	-	-	-	-
Cylinder High	-	-	-	-	-	-	-	-
Device/Head	-	-	-	-	-	-	-	-
Status	...See Below...							

Error Register							
7	6	5	4	3	2	1	0
CRC	UNC	0	IDN	0	ABT	T0N	AMN
0	V	0	0	0	V	0	0

Status Register							
7	6	5	4	3	2	1	0
BSY	RDY	DF	DSC	DRQ	COR	IDX	ERR
0	V	0	-	-	0	-	V

Figure 92. Security Unlock Command (F2h)

This command unlocks the password and causes the device to enter device unlock mode. If power on reset or hard reset is done without executing the Security Disable Password command after this command is completed, the device will be in device lock mode. The password has not been changed yet.

The Security Unlock command requests to transfer a single sector of data from the host including information specified in Figure 93 on page 138.

If the Identifier bit is set to master and the file is in high security mode then the password supplied will be compared with the stored master password. If the file is in maximum security mode then the security unlock will be rejected.

If the Identifier bit is set to user, then the file compares the supplied password with the stored user password.

If the password compare fails then the device returns an abort error to the host and decrements the unlock attempt counter. This counter is initially set to 5 and is decremented for each password mismatch. When this counter reaches zero then all password protected commands are rejected until a hard reset or a power off.

Word	Description
00	Control word bit 0 : Identifier (1- Master, 0- User) bit 1-15 : Reserved
01-16	Password (32 bytes)
17-255	Reserved

Figure 93. Security Unlock Information

Identifier Zero indicates that device regards Password as User Password. One indicates that device regards Password as Master Password.

The user can detect if the attempt to unlock the device has failed due to a mismatched password as this is the only reason that an abort error will be returned by the file AFTER the password information has been sent to the device. If an abort error is returned by the device BEFORE the password data has been sent to the file then another problem exists.

12.25 Seek (7xh)

Command Block Output Registers								
Register	7	6	5	4	3	2	1	0
Data	-	-	-	-	-	-	-	-
Feature	-	-	-	-	-	-	-	-
Sector Count	-	-	-	-	-	-	-	-
Sector Number	V	V	V	V	V	V	V	V
Cylinder Low	V	V	V	V	V	V	V	V
Cylinder High	V	V	V	V	V	V	V	V
Device/Head	1	L	1	D	H	H	H	H
Command	0	1	1	1	-	-	-	-

Command Block Input Registers								
Register	7	6	5	4	3	2	1	0
Data	-	-	-	-	-	-	-	-
Error	...See Below...							
Sector Count	-	-	-	-	-	-	-	-
Sector Number	V	V	V	V	V	V	V	V
Cylinder Low	V	V	V	V	V	V	V	V
Cylinder High	V	V	V	V	V	V	V	V
Device/Head	-	-	-	-	H	H	H	H
Status	...See Below...							

Error Register							
7	6	5	4	3	2	1	0
CRC	UNC	0	IDN	0	ABT	T0N	AMN
0	0	0	V	0	V	0	0

Status Register							
7	6	5	4	3	2	1	0
BSY	RDY	DF	DSC	DRQ	COR	IDX	ERR
0	V	0	V	-	0	-	V

Figure 94. Seek Command (7xh)

The Seek command initiates a seek to the designated track and selects the designated head. The device need not be formatted for a seek to execute properly.

Output Parameters To The Device

Sector Number In LBA mode, this register specifies LBA address bits 0 - 7 for seek. (L=1)

Cylinder High/Low The cylinder number of the seek.

In LBA mode, this register specifies LBA address bits 8 - 15 (Low), 16 - 23 (High) for seek. (L=1)

H The head number of the seek.

In LBA mode, this register specifies LBA address bits 24 - 27 for seek. (L=1)

Input Parameters From The Device

Sector Number In LBA mode, this register contains current LBA bits 0 - 7. (L=1)

Cylinder High/Low In LBA mode, this register contains current LBA bits 8 - 15 (Low), 16 - 23 (High). (L=1)

H In LBA mode, this register contains current LBA bits 24 - 27. (L=1)

12.26 Set Features (EFh)

Command Block Output Registers								
Register	7	6	5	4	3	2	1	0
Data	-	-	-	-	-	-	-	-
Feature	V	V	V	V	V	V	V	V
Sector Count	Note.1							
Sector Number	-	-	-	-	-	-	-	-
Cylinder Low	-	-	-	-	-	-	-	-
Cylinder High	-	-	-	-	-	-	-	-
Device/Head	1	-	1	D	-	-	-	-
Command	1	1	1	0	1	1	1	1

Command Block Input Registers								
Register	7	6	5	4	3	2	1	0
Data	-	-	-	-	-	-	-	-
Error	...See Below...							
Sector Count	-	-	-	-	-	-	-	-
Sector Number	-	-	-	-	-	-	-	-
Cylinder Low	-	-	-	-	-	-	-	-
Cylinder High	-	-	-	-	-	-	-	-
Device/Head	-	-	-	-	-	-	-	-
Status	...See Below...							

Error Register							
7	6	5	4	3	2	1	0
CRC	UNC	0	IDN	0	ABT	T0N	AMN
0	0	0	0	0	V	0	0

Status Register							
7	6	5	4	3	2	1	0
BSY	RDY	DF	DSC	DRQ	COR	IDX	ERR
0	V	0	-	-	0	-	V

Figure 95. Set Features Command (EFh)

The Set Feature command establishes the following parameters which affect the execution of certain features as shown in below table.

ABT will be set to 1 in the Error Register if the Feature register contains any undefined values.

Output Parameters To The Device

Feature	Destination code for this command.
02H	Enable write cache (Warning.1)
03H	Set transfer mode based on value in sector count register
05H	Enable Advanced Power Management
09H	Enable Address Offset mode
44H	34 bytes of ECC apply on Read Long/Write Long commands
55H	Disable read look-ahead feature
66H	Disable reverting to power on defaults
82H	Disable write cache
85H	Disable Advanced Power Management
89H	Disable Address Offset mode

AAH Enable read look-ahead feature

BBH 4 bytes of ECC apply on Read Long/Write Long commands

CCH Enable reverting to power on defaults

Warning 1. Hard reset or power off must not be done in 5 seconds after write command completion when write cache is enabled.

Note 1.

When Feature register is 03h (=Set Transfer mode), the Sector Count Register specifies the transfer mechanism. The upper 5 bits define the type of transfer and the low order 3 bits encode the mode value.

PIO Default Transfer Mode	00000	000
PIO Default Transfer Mode,Disable IORDY	00000	001
PIO Flow Control Transfer Mode x	00001	nnn (nnn=000,001,010,011,100)
Single word DMA mode x	00010	nnn (nnn=000,001,010)
Multiword DMA mode x	00100	nnn (nnn=000,001,010)
Ultra DMA mode x	01000	nnn (nnn=000,001,010)

Note 2.

When Feature register is 05h (=Enable Advanced Power Management), the Sector Count Register specifies the Advanced Power Management level.

C0h - FEh	...	The deepest Power Saving mode is Active Idle
80h - BFh	...	The deepest Power Saving mode is Low power Idle
01h - 7Fh	...	The deepest Power Saving mode is Standby
00h, FFh	...	Aborted

When Feature register is 85h (=Disable Advanced Power Management), the deepest Power Saving mode becomes Active Idle.

Note 3.

If the number of auto reassigned sectors reaches the device's reassignment capacity, the write cache function will be automatically disabled. Although the device still accepts the Set Features command (with Feature register = 02h) without error, the write cache function will remain disabled. For current write cache function status, please refer to the Identify Device Information(129word) by Identify Device command.

Note 4.

After power on reset or hard reset, the device is set to the following features as default.

Write cache	:	Enable
ECC bytes	:	4 bytes
Read look-ahead	:	Enable
Reverting to power on defaults	:	Disable
Address Offset mode	:	Disable

12.27 Set Max Address (F9h)

Command Block Output Registers							
Register	7	6	5	4	3	2	1 0
Data	-	-	-	-	-	-	-
Feature	-	-	-	-	-	-	-
Sector Count	-	-	-	-	-	-	B
Sector Number	V	V	V	V	V	V	V
Cylinder Low	V	V	V	V	V	V	V
Cylinder High	V	V	V	V	V	V	V
Device/Head	1	L	1	D	H	H	H
Command	1	1	1	1	1	0	0 1

Command Block Input Registers							
Register	7	6	5	4	3	2	1 0
Data	-	-	-	-	-	-	-
Error	...See Below...						
Sector Count	-	-	-	-	-	-	-
Sector Number	V	V	V	V	V	V	V
Cylinder Low	V	V	V	V	V	V	V
Cylinder High	V	V	V	V	V	V	V
Device/Head	-	-	-	-	H	H	H
Status	...See Below...						

Error Register							
7	6	5	4	3	2	1	0
CRC	UNC	0	IDN	0	ABT	T0N	AMN
0	0	0	0	0	V	0	0

Status Register							
7	6	5	4	3	2	1	0
BSY	RDY	DF	DSC	DRQ	COR	IDX	ERR
0	V	0	-	-	0	-	V

Figure 96. Set Max Address (F9h)

This command overwrites the max LBA/CYL of HDD in a range of actual device capacities. Once device receives this command, all accesses beyond that LBA/CYL are rejected with setting ABORT bit in status register. Identify device command and Identify device DMA command returns the LBA/CYL which is set via this command as a default value.

Read Native Max Address command should be issued and completed immediately prior to issuing Set Max Address command. If the device receives Set Max Address command without a prior Read Native Max Address command, the device aborts the Set Max Address command.

In CHS mode, Cylinder High, Cylinder Low specify the max cylinder number. The Head number of DEVICE/HEAD and Sector Number are ignored. The default value (See default CHS in Identify device information) is used for that.

In LBA mode, the Head number of DEVICE/HEAD, Cylinder High, Cylinder Low and Sector Number specify the max LBA. This command will be set this LBA as the max LBA of the device.

Output Parameters To The Device

B Option bit for selection whether nonvolatile or volatile. B=0 is volatile condition. When B=1, MAX LBA/CYL which is set by Set Max Address command is preserved by POR and HARD RESET. When B=0, MAX LBA/CYL which is set by Set Max Address command will be lost by POR and HARD RESET. B=1 is not valid when the device is in Address Offset mode, and the command is aborted.

Sector Number	In LBA mode, this register contains LBA bits 0 - 7 which is to be input.(L=1) In CHS mode, this register is ignored. (L=0)
Cylinder High/Low	In LBA mode, this register contains LBA bits 8 - 15 (Low), 16 - 23 (High) which is to be set. (L=1) In CHS mode, this register contains cylinder number which is to be input.(L=0)
H	In LBA mode, this register contains LBA bits 24 - 27 which is to be input.(L=1) In CHS mode, this register is ignored. (L=0)
L	LBA mode.Indicates the addressing mode.L=0 specifies CHS mode and L=1 does LBA addressing mode.
D	The device number bit. Indicates that the device number bit of the Device/Head should be specified. D=0 selects the master device and D=1 selects the slave device.
V	Valid. Indicates that the bit is part of an output parameter and should be specified.
-	Indicates that the bit is not used.

Input Parameters From The Device

Sector Number	In LBA mode, this register contains Adjusted max LBA bits 0 - 7.(L=1) In CHS mode, this register contains max sector number(= 63). (L=0)
Cylinder High/Low	In LBA mode, this register contains Adjusted max LBA bits 8 - 15 (Low), 16 - 23 (High). (L=1) In CHS mode, this register contains max cylinder number which is set. (L=0)
H	In LBA mode, this register contains Adjusted max LBA bits 24 - 27. (L=1) In CHS mode, this register contains max head number(= 15).(L=0)
V	Valid. Indicates that the bit is part of an input parameter and will be set to 0 or 1 by the device.
-	Indicates that the bit is not used.

12.28 Set Multiple (C6h)

Command Block Output Registers							
Register	7	6	5	4	3	2	1 0
Data	-	-	-	-	-	-	-
Feature	-	-	-	-	-	-	-
Sector Count	V	V	V	V	V	V	V
Sector Number	-	-	-	-	-	-	-
Cylinder Low	-	-	-	-	-	-	-
Cylinder High	-	-	-	-	-	-	-
Device/Head	1	-	1	D	-	-	-
Command	1	1	0	0	0	1	1 0

Command Block Input Registers							
Register	7	6	5	4	3	2	1 0
Data	-	-	-	-	-	-	-
Error	...See Below...						
Sector Count	-	-	-	-	-	-	-
Sector Number	-	-	-	-	-	-	-
Cylinder Low	-	-	-	-	-	-	-
Cylinder High	-	-	-	-	-	-	-
Device/Head	-	-	-	-	-	-	-
Status	...See Below...						

Error Register							
7	6	5	4	3	2	1	0
CRC	UNC	0	IDN	0	ABT	T0N	AMN
0	0	0	0	0	V	0	0

Status Register							
7	6	5	4	3	2	1	0
BSY	RDY	DF	DSC	DRQ	COR	IDX	ERR
0	V	0	-	-	0	-	V

Figure 97. Set Multiple Command (C6h)

The Set Multiple command enables the device to perform Read and Write Multiple commands and establishes the block size for these commands. The block size is the number of sectors to be transferred for each interrupt.

The default block size after power up, or hard reset is 0, and Read Multiple and Write Multiple commands are disabled.

If an invalid block size is specified, an Abort error will be returned to the host, and Read Multiple and Write Multiple commands will be disabled.

Output Parameters To The Device

Sector Count. The block size to be used for Read Multiple and Write Multiple commands. Valid block sizes can be selected from 0, 2, 4, 8 or 16. If 0 is specified, then Read Multiple and Write Multiple commands are disabled.

12.29 Sleep (E6h/99h)

Command Block Output Registers								
Register	7	6	5	4	3	2	1	0
Data	-	-	-	-	-	-	-	-
Feature	-	-	-	-	-	-	-	-
Sector Count	-	-	-	-	-	-	-	-
Sector Number	-	-	-	-	-	-	-	-
Cylinder Low	-	-	-	-	-	-	-	-
Cylinder High	-	-	-	-	-	-	-	-
Device/Head	1	-	1	D	-	-	-	-
Command	1	1	1	0	0	1	1	0

Command Block Input Registers								
Register	7	6	5	4	3	2	1	0
Data	-	-	-	-	-	-	-	-
Error	...See Below...							
Sector Count	-	-	-	-	-	-	-	-
Sector Number	-	-	-	-	-	-	-	-
Cylinder Low	-	-	-	-	-	-	-	-
Cylinder High	-	-	-	-	-	-	-	-
Device/Head	-	-	-	-	-	-	-	-
Status	...See Below...							

Error Register							
7	6	5	4	3	2	1	0
CRC	UNC	0	IDN	0	ABT	TON	AMN
0	0	0	0	0	V	0	0

Status Register							
7	6	5	4	3	2	1	0
BSY	RDY	DF	DSC	DRQ	COR	IDX	ERR
0	V	0	V	-	0	-	V

Figure 98. Sleep Command (E6h/99h)

This command is the only way to cause the device to enter Sleep Mode.

When this command is issued, the device confirms the completion of the cached write commands before it asserts INTRQ. Then the device is spun down, and the interface becomes inactive. The only way to recover from Sleep Mode is with a software reset or a hardware reset.

The use of hardware reset to recover from Sleep Mode may be incompatible with continued operation of the host system.

If the device is already spun down, the spin down sequence is not executed.

12.30 S.M.A.R.T. Function Set (B0h)

Command Block Output Registers								
Register	7	6	5	4	3	2	1	0
Data	-	-	-	-	-	-	-	-
Feature	V	V	V	V	V	V	V	V
Sector Count	V	V	V	V	V	V	V	V
Sector Number	-	-	-	-	-	-	-	-
Cylinder Low	0	1	0	0	1	1	1	1
Cylinder High	1	1	0	0	0	0	1	0
Device/Head	1	-	1	D	-	-	-	-
Command	1	0	1	1	0	0	0	0

Command Block Input Registers								
Register	7	6	5	4	3	2	1	0
Data	-	-	-	-	-	-	-	-
Error	...See Below...							
Sector Count	-	-	-	-	-	-	-	-
Sector Number	-	-	-	-	-	-	-	-
Cylinder Low	-	-	-	-	-	-	-	-
Cylinder High	-	-	-	-	-	-	-	-
Device/Head	-	-	-	-	-	-	-	-
Status	...See Below...							

Error Register							
7	6	5	4	3	2	1	0
CRC	UNC	0	IDN	0	ABT	T0N	AMN
0	0	0	0	0	V	0	0

Status Register							
7	6	5	4	3	2	1	0
BSY	RDY	DF	DSC	DRQ	COR	IDX	ERR
0	V	0	V	-	0	-	V

Figure 99. S.M.A.R.T. Function Set Command (B0h)

The S.M.A.R.T. Function Set command provides access to Attribute Values, Attribute Thresholds and other low level subcommands that can be used for logging and reporting purposes and to accommodate special user needs. The S.M.A.R.T. Function Set command has several separate subcommands which are selectable via the device's Features Register when the S.M.A.R.T. Function Set command is issued by the host.

In order to select a subcommand the host must write the subcommand code to the device's Features Register before issuing the S.M.A.R.T. Function Set command. The subcommands and their respective codes are listed below.

Code	Subcommand
D0h	SMART Read Attribute Values
D1h	SMART Read Attribute Thresholds
D2h	SMART Enable/disable Attribute Autosave
D3h	SMART Save Attribute Values
D4h	SMART Execute Off-line Immediate
D8h	SMART Enable Operations
D9h	SMART Disable Operations

12.30.1.1 SMART Read Attribute Values (Subcommand D0h)

This subcommand returns the device's Attribute Values to the host. Upon receipt of the SMART Read Attribute Values subcommand from the host, the device asserts BSY, saves any updated Attribute Values to the Attribute Data sectors, asserts DRQ, clears BSY, asserts INTRQ, and then waits for the host to transfer the 512 bytes of Attribute Value information from the device via the Data Register.

12.30.1.2 SMART Read Attribute Thresholds (Subcommand D1h)

This subcommand returns the device's Attribute Thresholds to the host. Upon receipt of the SMART Read Attribute Thresholds subcommand from the host, the device asserts BSY, reads the Attribute Thresholds from the Attribute Threshold sectors, asserts DRQ, clears BSY, asserts INTRQ, and then waits for the host to transfer the 512 bytes of Attribute Thresholds information from the device via the Data Register.

12.30.1.3 SMART Enable/Disable Attribute Autosave (Subcommand D2h)

This subcommand enables and disables the attribute autosave feature of the device. The SMART Enable/Disable Attribute Autosave subcommand allows the device to automatically save its updated Attribute Values to the Attribute Data Sector at the timing of the first transition to Active idle mode after 30 minutes since the last saving of Attribute Values; this subcommand causes the autosave feature to be disabled. The state of the Attribute Autosave feature (either enabled or disabled) will be preserved by the device across power cycle.

A value of 00h written by the host into the device's Sector Count Register before issuing the SMART Enable/Disable Attribute Autosave subcommand will cause this feature to be disabled. Disabling this feature does not preclude the device from saving Attribute Values to the Attribute Data sectors during some other normal operation such as during a power-up or power-down.

A value of F1h written by the host into the device's Sector Count Register before issuing the SMART Enable/Disable Attribute Autosave subcommand will cause this feature to be enabled. Any other non-zero value written by the host into this register before issuing the SMART Enable/Disable Attribute Autosave subcommand will not change the current Autosave status but the device will respond with the error code specified in Figure 105 on page 158.

The SMART Disable Operations subcommand disables the autosave feature along with the device's SMART operations.

Upon the receipt of the subcommand from the host, the device asserts BSY, enables or disables the Autosave feature, clears BSY and asserts INTRQ.

12.30.1.4 SMART Save Attribute Values (Subcommand D3h)

This subcommand causes the device to immediately save any updated Attribute Values to the device's Attribute Data sector regardless of the state of the Attribute Autosave feature. Upon receipt of the SMART Save Attribute Values subcommand from the host, the device asserts BSY, writes any updated Attribute Values to the Attribute Data sector, clears BSY and asserts INTRQ.

12.30.1.5 SMART Execute Off-line Immediate (Subcommand D4h)

This subcommand causes the device to immediately initiate the set of off-line data collection activities that collect attribute data in an off-line mode.

Upon receipt of the subcommand from the host, the device sets BSY to one, begins its set of off-line data collection activities, clears BSY to zero and asserts INTRQ.

During execution of its off-line activities the device will not set BSY nor clear DRDY.

If the device is in the process of performing its set of off-line data collection activities as a result of receiving a SMART Execute Off-line Immediate subcommand from the host and is interrupted by any new command from the host, the device will abort its off-line data collection activities and service the host within two seconds after receipt of the new command. Off-line data collection activity must be restarted by a new SMART Execute Off-line Immediate subcommand from the host.

An issuance of this subcommand just initiates only one off-line test item (called a “segment”). Once a segment completes, the device just advances the current segment pointer to next one and set the off-line data collection status to be 01h (“A segment completed”), then terminates off-line activity. The host shall continue to issue this subcommand until off-line data collection status is set to 02h (“All Segments Completed”) in order to perform all set of off-line segments.

The host can obtain device's estimated time to complete the current segment, along with the off-line data collection status, by issuing a SMART Read Attribute Values subcommand. Since the device may not complete a segment within its estimated time, an issuance of a SMART Read Attribute Values subcommand could abort ongoing off-line test. In this case, the current segment pointer remains unchanged and off-line data collection status is set to 05h (as any other commands do for ongoing off-line test).

12.30.1.6 SMART Enable Operations (Subcommand D8h)

This subcommand enables access to all S.M.A.R.T. capabilities within the device. Prior to receipt of a SMART Enable Operations subcommand, Attribute Values are neither monitored nor saved by the device. The state of S.M.A.R.T. (either enabled or disabled) will be preserved by the device across power cycles. Once enabled, the receipt of subsequent SMART Enable Operations subcommands will not affect any of the Attribute Values.

Upon receipt of the SMART Enable Operations subcommand from the host, the device asserts BSY, enables S.M.A.R.T. capabilities and functions, clears BSY and asserts INTRQ.

12.30.1.7 SMART Disable Operations (Subcommand D9h)

This subcommand disables all S.M.A.R.T. capabilities within the device including the device's attribute autosave feature. After receipt of this subcommand the device disables all S.M.A.R.T. operations. Non self-preserved Attribute Values will no longer be monitored. The state of S.M.A.R.T. (either enabled or disabled) is preserved by the device across power cycles. Note that this subcommand does not preclude the device's power mode attribute autosaving.

Upon receipt of the SMART Disable Operations subcommand from the host, the device asserts BSY, disables S.M.A.R.T. capabilities and functions, clears BSY and asserts INTRQ.

After receipt of the device of the SMART Disable Operations subcommand from the host, all other S.M.A.R.T. subcommands -- with the exception of SMART Enable Operations -- are disabled, and invalid

and will be aborted by the device (including the SMART Disable Operations subcommand), returning the error code as specified in Figure 105 on page 158.

Any Attribute Values accumulated and saved to volatile memory prior to receipt of the SMART Disable Operations command will be preserved in the device's Attribute Data Sectors. If the device is re-enabled, these Attribute Values will be updated, as needed, upon receipt of a SMART Read Attribute Values or SMART Save Attribute Values command.

12.30.1.8 SMART Return Status (Subcommand DAh)

This command is used to communicate the reliability status of the device to the host's request. Upon receipt of the SMART Return Status subcommand the device asserts BSY, saves any updated Attribute Values to the reserved sector and compares the updated Attribute Values to the Attribute Thresholds.

If the device does not detect a Threshold Exceeded Condition, or detects a Threshold Exceeded Condition but involving attributes are advisory, the device loads 4Fh into the Cylinder Low register, C2h into the Cylinder High register, clears BSY, and asserts INTRQ.

If the device detects a Threshold Exceeded Condition for prefailure attributes, the device loads F4h into the Cylinder Low register, 2Ch into the Cylinder High register, clears BSY, and asserts INTRQ. Advisory attributes never result in negative reliability condition.

12.30.2 Device Attributes Data Structure

The following defines the 512 bytes that make up the Attribute Value information. This data structure is accessed by the host in its entirety using the SMART Read Attribute Values subcommand. All multi-byte fields shown in these data structures follow the ATA-3 specification for byte ordering, namely that the least significant byte occupies the lowest numbered byte address location in the field.

Description	Bytes	Offset	Format	Value
Data Structure Revision Number	2	00h	binary	0005h
1st Device Attribute	12	02h	(*1)	(*2)
...	..			
...	..			
30th Device Attribute	12	15Eh	(*1)	(*2)
Off-line data collection status	1	16Ah	(*1)	(*2)
Total segments required for off-line data collection	1	16Bh	(*1)	01h
Total time in seconds to complete next segment	2	16Ch	(*1)	(*2)
Current segment pointer	1	16Eh	(*1)	(*2)
Off-line data collection capability	1	16Fh	(*1)	05h
S.M.A.R.T. capability	2	170h	(*1)	03h
Reserved	16	172h		(*3)
Vendor specific	125	182h		(*3)
Data structure checksum	1	1FFh		(*2)
	512			

- (*1) – See following definitions
- (*2) – Value varied by actual operating condition
- (*3) – Filled with 00h

Figure 100. Device Attribute Data Structure

12.30.2.1 Data Structure Revision Number

The Data Structure Revision Number identifies which version of this data structure is implemented by the device. This revision number will be set to 0005h. This revision number identifies both the Attribute Value and Attribute Threshold Data structures.

12.30.2.2 Individual Attribute Data Structure

The following defines the 12 bytes that make up the information for each Attribute entry in the Device Attribute Data Structure.

Description	Bytes	Offset	Format
Attribute ID Number (01h to FFh)	1	00h	binary
Status Flags	2	01h	bit flags
Bit 0 Pre-Failure/Advisory			
Bit 1 On-line Collection			
Bit 2-5 Reserved (may either 0 or 1)			
Bit 6-15 Reserved (all 0)			
Attribute Value (valid values from 01h to FEh)	1	03h	binary
00h invalid for attribute value – not to be used			
01h minimum value			
64h initial value for all attributes prior to any data collection			
FDh maximum value			
FEh value is not valid			
FFh invalid for attribute value – not to be used			
Reserved (may not be 0)	1	04h	binary
Reserved (may not be 0)	6	05h	binary
Reserved (00h)	1	0Bh	binary
Total Bytes	12		

Figure 101. Individual Attribute Data Structure

12.30.2.2.1 Attribute ID Numbers: Any non-zero value in the Attribute ID Number indicates an active attribute. The device supports following Attribute ID Numbers. Those marked with (*) indicate that corresponding Attribute Values can be either collected on-line or off-line.

ID	Attribute Name
0	Indicates that this entry in the data structure is not used
1	Raw Read Error Rate (*)
2	Throughput Performance (*)
3	Spin Up Time
4	Start/Stop Count
5	Reallocated Sector Count

7	Seek Error Rate
8	Seek Time Performance (*)
9	Power-On Hours Count
10	Spin Retry Count
12	Device Power Cycle Count
199	CRC Error Count
220	Disk Shift
221	G-Sense Error Rate
222	Loaded Hours
223	Load Retry Count
224	Load Friction
225	Load Cycle Count
226	Load-in Time
227	Torq-amp Count
228	Power-off Retract Count

12.30.2.2.2 Status Flag Definitions

Bit	Flag Name	Definition
0	Pre-Failure/ Advisory bit	If bit = 0, an Attribute Value less than or equal to its corresponding Attribute Threshold indicates an Advisory condition where the usage or age of the device has exceeded its intended design life period. If bit = 1, an Attribute Value less than or equal to its corresponding Attribute Threshold indicates a Pre-Failure condition where imminent loss of data is being predicted.
1	On-Line Collective bit	If bit = 0, the Attribute Value is updated only during Off-Line testing. If bit = 1, the Attribute Value is updated only during On-Line testing
2-5	Reserved bits	may either 0 or 1
6-15	Reserved bits	Always 0

Figure 102. Status Flag Definitions

12.30.2.2.3 Normalized Values: The device will perform conversion of the raw Attribute Values to transform them into normalized values, which the host can then compare with the Threshold values. A Threshold is the excursion limit for a normalized Attribute Value. In normalizing the raw data, the device will perform any necessary statistical validity checks to ensure that an instantaneous raw value is not improperly reflected in the normalized Attribute Value (i.e., one read error in the first 10 reads being interpreted as exceeding the read error rate threshold when the subsequent 1 billion reads all execute without error). The end points for the normalized values for all Attributes will be 1 (01h) at the low end, and 100 (64h) at the high end for the device. For Performance and Error Rate Attributes, values greater than 100 are also possible, up to a maximum value of 253 (FDh).

12.30.2.3 Off-Line Data Collection Status

The value of this byte defines the current status of the off-line activities of the device. Bit 7 indicates Automatic Off-Line Data Collection Status.

Bit 7 Automatic Off-Line Data Collection Status

0 Automatic Off-Line Data Collection is enabled.

1 Automatic Off-Line Data Collection is disabled.

Bits 0 thru 6 represents a hexadecimal status value reported by the device.

Value Definition

0 Off-line data collection never started

- 1 Segment completed without error
- 2 All segments completed without errors. In this case, current segment pointer equals to total segments required.
- 5 Off-line data collecting aborted by interrupting command
- 6 Off-line data collection aborted with fatal error

12.30.2.4 Total Segments Required for Off-line Data Collection

The device will return 01h as the total segments for off-line data collection. A segment is a unit of off-line data collection activity. The device divides its segment into 7 subsegments. A subsegment is not a host-visible test unit. Subsegment 1 through 4 are raw read error rate and throughput measurement. Each of them reads from LBA 0000h to 95040h, resulting the total number of read bits to be 10000269312. Subsegment 5 is 1680 track to track seeks. Subsegment 6 is 1680 1/3 stroke seeks. Subsegment 7 = 1680 full stroke seeks.

12.30.2.5 Total Time in Seconds to Complete Next Segment

This field tells the host how many seconds the device requires to complete the segment pointed by the current segment pointer. The host can use this time to set a count down timer that will trigger it to issue the “SMART Read Attribute Values” subcommand to check on the status of off-line data collection. Because the number of segments is 1, this field always indicates the total time in seconds for whole off-line data collection activity.

12.30.2.6 Current Segment Pointer

This byte is a counter indicating the next segment to execute as an off-line data collection activity. Because the number of segments is 1, 01h is always returned in this field.

12.30.2.7 Off-Line Data Collection Capability

The device returns 05h as its off-line data collection capability which means:

Bit	Definition
0	Execute Off-line Immediate is implemented
1	Enable/Disable Automatic Off-line is NOT implemented
2	Abort/restart off-line by host

The device will abort all off-line data collection activity initiated by an S.M.A.R.T. Execute Off-line Immediate subcommand upon receipt of a new command. Off-line data collection activity must be restarted by a new S.M.A.R.T. Execute Off-line Immediate subcommand from the host.

12.30.2.8 S.M.A.R.T. Capability

This word of bit flags describes the S.M.A.R.T. capabilities of the device. The device will return 03h as its S.M.A.R.T. capability which means:

Bit	Definition
0	Power mode attribute saving capability If bit = 1, the device will save its Attribute Values prior to going into a power saving mode (Standby or Sleep mode).
1	Attribute autosave after event capability The device supports the S.M.A.R.T. Enable/Disable Attribute Autosave subcommand.
2-15	Reserved (0)

12.30.2.9 Data Structure Checksum

The Data Structure Checksum is the 2's compliment of the result of a simple 8-bit addition of the first 511 bytes in the data structure.

12.30.3 Device Attribute Thresholds Data Structure

The following defines the 512 bytes that make up the Attribute Threshold information. This data structure is accessed by the host in its entirety using the SMART Read Attribute Thresholds. All multi-byte fields shown in these data structures follow the ATA-3 specification for byte ordering, namely that the least significant byte occupies the lowest numbered byte address location in the field.

The sequence of active Attribute Thresholds will appear in the same order as their corresponding Attribute Values.

Description	Bytes	Offset	Format	Value
Data Structure Revision Number	2	00h	binary	0005h
1st Attribute Threshold	12	02h	(*1)	(*2)
...	..			
...	..			
30th Attribute Threshold	12	15Eh	(*1)	(*2)
Reserved	18	16Ah		(*3)
Vendor specific	131	17Ch		(*3)
Data structure checksum	1	1FFh		(*2)
	512			

- (*1) – See following definitions
- (*2) – Value varied by actual operating condition
- (*3) – Filled with 00h

Figure 103. Device Attribute Thresholds Data Structure

12.30.3.1 Data Structure Revision Number

This value (0005h) is the same as the value used in the Device Attributes Values Data Structure.

12.30.3.2 Individual Thresholds Data Structure

The following defines the 12 bytes that make up the information for each Threshold entry in the Device Attribute Thresholds Data Structure. Attribute entries in the Individual Threshold Data Structure is in the same order and correspond to the entries in the Individual Attribute Data Structure.

Description	Bytes	Offset	Format
Attribute ID Number (01h to FFh)	1	00h	binary
Attribute Threshold (for comparison with Attribute Values from 00h to FFh)	1	01h	binary
00h – "always passing" threshold value to be used for code test purposes			
01h – minimum value for normal operation			
FDh – maximum value for normal operation			
FEh – invalid for threshold value			
FFh – "always failing" threshold value to be used for code test purposes			
Reserved (00h)	10	02h	binary
Total Bytes	12		

Figure 104. Individual Threshold Data Structure

12.30.3.3 Attribute ID Numbers

Attribute ID Numbers supported by the device are the same as Attribute Values Data Structures.

12.30.3.4 Attribute Threshold

These values are preset at the factory and are not meant to be changeable.

12.30.3.5 Data Structure Checksum

The Data Structure Checksum is the 2's compliment of the result of a simple 8-bit addition of the first 511 bytes in the data structure.

12.30.4 Error Reporting

The following table shows the values returned in the Status and Error Registers when specific error conditions are encountered by a device.

Error Condition	Status Register	Error Register
A S.M.A.R.T. FUNCTION SET command was received by the device without the required key being loaded into the Cylinder High and Cylinder Low registers.	51h	04h
A S.M.A.R.T. FUNCTION SET command was received by the device with a subcommand value in the Features Register that is either invalid or not supported by this device.	51h	04h
A S.M.A.R.T. FUNCTION SET command subcommand other than SMART ENABLE OPERATIONS was received by the device while the device was in a "S.M.A.R.T. disabled" state.	51h	04h
The device is unable to read its Attribute Values or Attribute Thresholds data structure.	51h	10h or 40h
The device is unable to write to its Attribute Values data structure.	51h	10h or 01h

Figure 105. S.M.A.R.T. Error Codes

12.31 Standby (E2h/96h)

Command Block Output Registers								
Register	7	6	5	4	3	2	1	0
Data	-	-	-	-	-	-	-	-
Feature	-	-	-	-	-	-	-	-
Sector Count	V	V	V	V	V	V	V	V
Sector Number	-	-	-	-	-	-	-	-
Cylinder Low	-	-	-	-	-	-	-	-
Cylinder High	-	-	-	-	-	-	-	-
Device/Head	1	-	1	D	-	-	-	-
Command	1	1	1	0	0	0	1	0

Command Block Input Registers								
Register	7	6	5	4	3	2	1	0
Data	-	-	-	-	-	-	-	-
Error	...See Below...							
Sector Count	-	-	-	-	-	-	-	-
Sector Number	-	-	-	-	-	-	-	-
Cylinder Low	-	-	-	-	-	-	-	-
Cylinder High	-	-	-	-	-	-	-	-
Device/Head	-	-	-	-	-	-	-	-
Status	...See Below...							

Error Register							
7	6	5	4	3	2	1	0
CRC	UNC	0	IDN	0	ABT	T0N	AMN
0	0	0	0	0	V	0	0

Status Register							
7	6	5	4	3	2	1	0
BSY	RDY	DF	DSC	DRQ	COR	IDX	ERR
0	V	0	V	-	0	-	V

Figure 106. Standby Command (E2h/96h)

The Standby command causes the device to enter the Standby Mode immediately, and set auto power down timeout parameter(standby timer).

When this command is issued, the device confirms the completion of the cached write commands before it asserts INTRQ. Then the device is spun down, but the interface remains active.

If the device is already spun down, the spin down sequence is not executed.

During the Standby mode the device will respond to commands, but there is a delay while waiting for the spindle to reach operating speed.

The timer starts counting down when the device returns to Idle mode.

Output Parameters To The Device

Sector Count Timeout Parameter. If zero, the timeout interval(Standby Timer) is NOT disabled, but the timeout interval is set for 109 minutes automatically. If other than zero, the timeout interval is set for (Timeout Parameter × 5) seconds.

When the automatic power down sequence is enabled,

The device will enter Standby mode automatically if the timeout interval expires with no device access from the host. The timeout interval will be reinitialized if there is a device access before the timeout interval expires.

12.32 Standby Immediate (E0h/94h)

Command Block Output Registers								
Register	7	6	5	4	3	2	1	0
Data	-	-	-	-	-	-	-	-
Feature	-	-	-	-	-	-	-	-
Sector Count	-	-	-	-	-	-	-	-
Sector Number	-	-	-	-	-	-	-	-
Cylinder Low	-	-	-	-	-	-	-	-
Cylinder High	-	-	-	-	-	-	-	-
Device/Head	1	-	1	D	-	-	-	-
Command	1	1	1	0	0	0	0	0

Command Block Input Registers								
Register	7	6	5	4	3	2	1	0
Data	-	-	-	-	-	-	-	-
Error	...See Below...							
Sector Count	-	-	-	-	-	-	-	-
Sector Number	-	-	-	-	-	-	-	-
Cylinder Low	-	-	-	-	-	-	-	-
Cylinder High	-	-	-	-	-	-	-	-
Device/Head	-	-	-	-	-	-	-	-
Status	...See Below...							

Error Register							
7	6	5	4	3	2	1	0
CRC	UNC	0	IDN	0	ABT	T0N	AMN
0	0	0	0	0	V	0	0

Status Register							
7	6	5	4	3	2	1	0
BSY	RDY	DF	DSC	DRQ	COR	IDX	ERR
0	V	0	V	-	0	-	V

Figure 107. Standby Immediate Command (E0h/94h)

The Standby Immediate command causes the device to enter Standby mode immediately.

When this command is issued, the device confirms the completion of the cached write commands before asserts INTRQ. Then the device is spun down, but the interface remains active.

If the device is already spun down, the spin down sequence is not executed.

During the Standby mode, the device will respond to commands, but there is a delay while waiting for the spindle to reach operating speed.

The Standby Immediate command will not affect the auto power down timeout parameter.

12.33 Write Buffer (E8h)

Command Block Output Registers								
Register	7	6	5	4	3	2	1	0
Data	-	-	-	-	-	-	-	-
Feature	-	-	-	-	-	-	-	-
Sector Count	-	-	-	-	-	-	-	-
Sector Number	-	-	-	-	-	-	-	-
Cylinder Low	-	-	-	-	-	-	-	-
Cylinder High	-	-	-	-	-	-	-	-
Device/Head	1	-	1	D	-	-	-	-
Command	1	1	1	0	1	0	0	0

Command Block Input Registers								
Register	7	6	5	4	3	2	1	0
Data	-	-	-	-	-	-	-	-
Error	...See Below...							
Sector Count	-	-	-	-	-	-	-	-
Sector Number	-	-	-	-	-	-	-	-
Cylinder Low	-	-	-	-	-	-	-	-
Cylinder High	-	-	-	-	-	-	-	-
Device/Head	-	-	-	-	-	-	-	-
Status	...See Below...							

Error Register							
7	6	5	4	3	2	1	0
CRC	UNC	0	IDN	0	ABT	T0N	AMN
0	0	0	0	0	V	0	0

Status Register							
7	6	5	4	3	2	1	0
BSY	RDY	DF	DSC	DRQ	COR	IDX	ERR
0	V	0	-	-	0	-	V

Figure 108. Write Buffer Command (E8h)

The Write Buffer command transfers a sector of data from the host to the sector buffer of the device. The sectors of data are transferred through the Data Register 16 bits at a time.

The Read Buffer and Write Buffer commands are synchronized such that sequential Write Buffer and Read Buffer commands access the same 512 byte within the buffer.

12.34 Write DMA (CAh/CBh)

Command Block Output Registers							
Register	7	6	5	4	3	2	1 0
Data	-	-	-	-	-	-	-
Feature	-	-	-	-	-	-	-
Sector Count	V	V	V	V	V	V	V
Sector Number	V	V	V	V	V	V	V
Cylinder Low	V	V	V	V	V	V	V
Cylinder High	V	V	V	V	V	V	V
Device/Head	1	L	1	D	H	H	H
Command	1	1	0	0	1	0	1 R

Command Block Input Registers							
Register	7	6	5	4	3	2	1 0
Data	-	-	-	-	-	-	-
Error	...See Below...						
Sector Count	V	V	V	V	V	V	V
Sector Number	V	V	V	V	V	V	V
Cylinder Low	V	V	V	V	V	V	V
Cylinder High	V	V	V	V	V	V	V
Device/Head	-	-	-	-	H	H	H
Status	...See Below...						

Error Register							
7	6	5	4	3	2	1	0
CRC	UNC	0	IDN	0	ABT	T0N	AMN
V	0	0	V	0	V	0	0

Status Register							
7	6	5	4	3	2	1	0
BSY	RDY	DF	DSC	DRQ	COR	IDX	ERR
0	V	V	V	-	0	-	V

Figure 109. Write DMA Command (CAh/CBh)

The Write DMA command transfers one or more sectors of data from the host to the device, then the data is written to the disk media.

The sectors of data are transferred through the Data Register 16 bits at a time.

The host initializes a slave-DMA channel prior to issuing the command. Data transfers are qualified by DMARQ and are performed by the slave-DMA channel. The device issues only one interrupt per command to indicate that data transfer has terminated and status is available.

If an uncorrectable error occurs, the write will be terminated at the failing sector.

Output Parameters To The Device

Sector Count The number of continuous sectors to be transferred. If zero is specified, then 256 sectors will be transferred.

Sector Number The sector number of the first sector to be transferred. (L=0)
In LBA mode, this register contains LBA bits 0 - 7. (L=1)

Cylinder High/Low The cylinder number of the first sector to be transferred. (L=0)
In LBA mode, this register contains LBA bits 8 - 15 (Low), 16 - 23 (High). (L=1)

- H** The head number of the first sector to be transferred. (L=0)
 In LBA mode, this register contains LBA bits 24 - 27. (L=1)
- R** The retry bit. If set to one, then retries are disabled. When write cache is enabled, they are ignored. (Ignoring the retry bit is in violation of ATA-3.)

Input Parameters From The Device

- Sector Count** The number of requested sectors not transferred. This will be zero, unless an unrecoverable error occurs.
- Sector Number** The sector number of the last transferred sector. (L=0)
 In LBA mode, this register contains current LBA bits 0 - 7. (L=1)
- Cylinder High/Low** The cylinder number of the last transferred sector. (L=0)
 In LBA mode, this register contains current LBA bits 8 - 15 (Low), 16 - 23 (High). (L=1)
- H** The head number of the last transferred sector. (L=0)
 In LBA mode, this register contains current LBA bits 24 - 27. (L=1)

12.35 Write Long (32h/33h)

Command Block Output Registers								
Register	7	6	5	4	3	2	1	0
Data	-	-	-	-	-	-	-	-
Feature	-	-	-	-	-	-	-	-
Sector Count	0	0	0	0	0	0	0	1
Sector Number	V	V	V	V	V	V	V	V
Cylinder Low	V	V	V	V	V	V	V	V
Cylinder High	V	V	V	V	V	V	V	V
Device/Head	1	L	1	D	H	H	H	H
Command	0	0	1	1	0	0	1	R

Command Block Input Registers								
Register	7	6	5	4	3	2	1	0
Data	-	-	-	-	-	-	-	-
Error	...See Below...							
Sector Count	-	-	-	-	-	-	-	V
Sector Number	V	V	V	V	V	V	V	V
Cylinder Low	V	V	V	V	V	V	V	V
Cylinder High	V	V	V	V	V	V	V	V
Device/Head	-	-	-	-	H	H	H	H
Status	...See Below...							

Error Register							
7	6	5	4	3	2	1	0
CRC	UNC	0	IDN	0	ABT	T0N	AMN
0	0	0	V	0	V	0	0

Status Register							
7	6	5	4	3	2	1	0
BSY	RDY	DF	DSC	DRQ	COR	IDX	ERR
0	V	V	V	-	0	-	V

Figure 110. Write Long Command (32h/33h)

The Write Long command transfers the data and the ECC bytes of the designated one sector from the host to the device, then the data and the ECC bytes are written to the disk media.

After 512 bytes of data have been transferred, the device will keep setting DRQ=1 to indicate that the device is ready to receive the ECC bytes from the host. The data is transferred 16 bits at a time, and the ECC bytes are transferred 8 bits at a time. The number of ECC bytes are 4 or 34 according to setting of Set Feature option. The default number after power on is 4 bytes.

Output Parameters To The Device

- Sector Count** The number of continuous sectors to be transferred. The Sector Count must be set to one.
- Sector Number** The sector number of the sector to be transferred. (L=0)
 In LBA mode, this register contains LBA bits 0 - 7. (L=1)
- Cylinder High/Low** The cylinder number of the sector to be transferred. (L=0)
 In LBA mode, this register contains LBA bits 8 - 15 (Low), 16 - 23 (High). (L=1)
- H** The head number of the sector to be transferred. (L=0)
 In LBA mode, this register contains LBA bits 24 - 27. (L=1)
- R** The retry bit. If set to one, then retries are disabled.

Input Parameters From The Device

Sector Count	The number of requested sectors not transferred.
Sector Number	The sector number of the sector to be transferred. (L=0) In LBA mode, this register contains current LBA bits 0 - 7. (L=1)
Cylinder High/Low	The cylinder number of the sector to be transferred. (L=0) In LBA mode, this register contains current LBA bits 8 - 15 (Low), 16 - 23 (High). (L=1)
H	The head number of the sector to be transferred. (L=0) In LBA mode, this register contains current LBA bits 24 - 27. (L=1)

The file internally uses 34 bytes of ECC on all data read or writes. The 4 byte mode of operation is provided via an emulation technique. As a consequence of this emulation it is recommended that 34 byte ECC mode is used for all tests to confirm the operation of the files ECC hardware. Unexpected results may occur if such testing is performed using 4 byte mode.

12.36 Write Multiple (C5h)

Command Block Output Registers								
Register	7	6	5	4	3	2	1	0
Data	-	-	-	-	-	-	-	-
Feature	-	-	-	-	-	-	-	-
Sector Count	V	V	V	V	V	V	V	V
Sector Number	V	V	V	V	V	V	V	V
Cylinder Low	V	V	V	V	V	V	V	V
Cylinder High	V	V	V	V	V	V	V	V
Device/Head	1	L	1	D	H	H	H	H
Command	1	1	0	0	0	1	0	1

Command Block Input Registers								
Register	7	6	5	4	3	2	1	0
Data	-	-	-	-	-	-	-	-
Error	...See Below...							
Sector Count	V	V	V	V	V	V	V	V
Sector Number	V	V	V	V	V	V	V	V
Cylinder Low	V	V	V	V	V	V	V	V
Cylinder High	V	V	V	V	V	V	V	V
Device/Head	-	-	-	-	H	H	H	H
Status	...See Below...							

Error Register							
7	6	5	4	3	2	1	0
CRC	UNC	0	IDN	0	ABT	T0N	AMN
0	0	0	V	0	V	0	0

Status Register							
7	6	5	4	3	2	1	0
BSY	RDY	DF	DSC	DRQ	COR	IDX	ERR
0	V	V	V	-	0	-	V

Figure 111. Write Multiple Command (C5h)

The Write Multiple command transfers one or more sectors from the host to the device, then the data is written to the disk media.

Command execution is identical to the Write Sectors command except that an interrupt is generated for each block (as defined by the Set Multiple command) instead of for each sector. The sectors are transferred through the Data Register 16 bits at a time.

Output Parameters To The Device

Sector Count The number of continuous sectors to be transferred. If zero is specified, then 256 sectors will be transferred.

Sector Number The sector number of the first sector to be transferred. (L=0)

In LBA mode, this register contains LBA bits 0 - 7. (L=1)

Cylinder High/Low The cylinder number of the first sector to be transferred. (L=0)

In LBA mode, this register contains LBA bits 8 - 15 (Low), 16 - 23 (High). (L=1)

H The head number of the first sector to be transferred. (L=0)

In LBA mode, this register contains LBA bits 24 - 27. (L=1)

Input Parameters From The Device

Sector Count	The number of requested sectors not transferred. This will be zero, unless an unrecoverable error occurs.
Sector Number	The sector number of the last transferred sector. (L=0) In LBA mode, this register contains current LBA bits 0 - 7. (L=1)
Cylinder High/Low	The cylinder number of the last transferred sector. (L=0) In LBA mode, this register contains current LBA bits 8 - 15 (Low), 16 - 23 (High). (L=1)
H	The head number of the last transferred sector. (L=0) In LBA mode, this register contains current LBA bits 24 - 27. (L=1)

12.37 Write Sectors (30h/31h)

Command Block Output Registers								
Register	7	6	5	4	3	2	1	0
Data	-	-	-	-	-	-	-	-
Feature	-	-	-	-	-	-	-	-
Sector Count	V	V	V	V	V	V	V	V
Sector Number	V	V	V	V	V	V	V	V
Cylinder Low	V	V	V	V	V	V	V	V
Cylinder High	V	V	V	V	V	V	V	V
Device/Head	1	L	1	D	H	H	H	H
Command	0	0	1	1	0	0	0	R

Command Block Input Registers								
Register	7	6	5	4	3	2	1	0
Data	-	-	-	-	-	-	-	-
Error	...See Below...							
Sector Count	V	V	V	V	V	V	V	V
Sector Number	V	V	V	V	V	V	V	V
Cylinder Low	V	V	V	V	V	V	V	V
Cylinder High	V	V	V	V	V	V	V	V
Device/Head	-	-	-	-	H	H	H	H
Status	...See Below...							

Error Register							
7	6	5	4	3	2	1	0
CRC	UNC	0	IDN	0	ABT	T0N	AMN
0	0	0	V	0	V	0	0

Status Register							
7	6	5	4	3	2	1	0
BSY	RDY	DF	DSC	DRQ	COR	IDX	ERR
0	V	V	V	-	0	-	V

Figure 112. Write Sectors Command (30h/31h)

The Write Sectors command transfers one or more sectors from the host to the device, then the data is written to the disk media.

The sectors are transferred through the Data Register 16 bits at a time.

If an uncorrectable error occurs, the write will be terminated at the failing sector, when the auto reassign function is disable.

Output Parameters To The Device

- Sector Count** The number of continuous sectors to be transferred. If zero is specified, then 256 sectors will be transferred.
- Sector Number** The sector number of the first sector to be transferred. (L=0)
In LBA mode, this register contains LBA bits 0 - 7. (L=1)
- Cylinder High/Low** The cylinder number of the first sector to be transferred. (L=0)
In LBA mode, this register contains LBA bits 8 - 15 (Low), 16 - 23 (High). (L=1)
- H** The head number of the first sector to be transferred. (L=0)
In LBA mode, this register contains LBA bits 24 - 27. (L=1)
- R** The retry bit. If set to one, then retries are disabled. But ignored, when write cache is enabled. (Ignoring the retry bit is in violation of ATA-3.)

Input Parameters From The Device

Sector Count	The number of requested sectors not transferred. This will be zero, unless an unrecoverable error occurs.
Sector Number	The sector number of the last transferred sector. (L=0) In LBA mode, this register contains current LBA bits 0 - 7. (L=1)
Cylinder High/Low	The cylinder number of the last transferred sector. (L=0) In LBA mode, this register contains current LBA bits 8 - 15 (Low), 16 - 23 (High). (L=1)
H	The head number of the last transferred sector. (L=0) In LBA mode, this register contains current LBA bits 24 - 27. (L=1)

12.38 Write Verify (3Ch: Vendor Specific)

In DCXA-2xxxxx implementation, Write Verify command is exactly same as Write Sectors command(30h). No read verification is performed after write operation.

Refer to Write Sectors Command for parameters.

13.0 Timeout Values

The timing of BSY and DRQ in Status Register are shown in Figure 113.

FUNCTION	INTERVAL	START	STOP	TIMEOUT
Power On	Device Busy After Power On	Power On	Status Register BSY=1	400 ns
	Device Ready After Power On	Power On	Status Register BSY=0 and RDY=1	31 sec
Software Reset	Device Busy After Software Reset	Device Control Register RST=1	Status Register BSY=1	400 ns
	Device Ready After Software Reset	Device Control Register RST=0 after RST=1	Status Register BSY=0 and RDY=1	31 sec
Hard Reset	Device Busy After Hard Reset	Bus RESET Signal Asserted	Status Register BSY=1	400 ns
	Device Ready After Hard Reset	Bus RESET Signal Asserted	Status Register BSY=0 and RDY=1	31 sec
Data In Command	Device Busy After Command Code Out	OUT to Command Register	Status Register BSY=1	400 ns
	Interrupt, DRQ For Data Transfer In	Status Register BSY=1	Status Register BSY=0 and DRQ=1, Interrupt	30 sec
	Device Busy After Data Transfer In	256th Read From Data Register	Status Register BSY=1	10 us
Data Out Command	Device Busy After Command Code Out	OUT to Command Register	Status Register BSY=1	400 ns
	Data Request For Data Transfer Out	Status Register BSY=1	Status Register BSY=0 and DRQ=1	700 us (Note.3)
	Device Busy After Data Transfer Out	256th Write From Data Register	Status Register BSY=1	5 us
	Interrupt For Data Transfer Out	Status Register BSY=1	Status Register BSY=0 and RDY=1 Interrupt	30 sec (Note.1)
Non-Data Command	Device Busy After Command Code Out	OUT to Command Register	Status Register BSY=1	400 ns
	Interrupt For Command Complete	Status Register BSY=1	Interrupt	30 sec (Note.2)

Figure 113. Timeout Values -- continued --

FUNCTION	INTERVAL	START	STOP	TIMEOUT
DMA Data Transfer Command	Device Busy after Command Code Out	Out to Command Register	Status Register BSY=1	400 ns

Figure 114. Timeout Values

Command category is referred to 11.0, “Command Protocol” on page 89.

The abbreviations "ns", "us", "ms" and "sec" mean nanoseconds, microseconds, milliseconds and seconds, respectively.

We recommend that the host system executes Soft reset and then retry to issue the command if the host system timeout would occur for the device.

- (Note.1)** For SECURITY ERASE UNIT command, the execution time is referred to 12.21, “Security Erase Unit (F4h)” on page 132.
- (Note.2)** For FORMAT UNIT command, the execution time is referred to 12.5, “Format Unit (F7h: Vendor Specific)” on page 104.
- (Note.3)** When the initial power mode at power on is Standby mode, and when the following commands are issued by the host as First Command, the command's timeout value of the field is 10 seconds.

Security Disable Password, Security Erase Unit,
Security Set Password, Security Unlock.

14.0 Appendix

14.1 Commands Support Coverage

Following table is provided to facilitate the understanding of DCXA-2xxxxx command support coverage comparing to the ATA-4 defined command set. The column of 'Implementation' shows the capability of DCXA-2xxxxx for those commands.

Command Code	Command Name	Implementation for DCXA-2xxxxx	ATA-4 Category
00h	NOP	No	Optional
03h	CFA REQUEST EXTENDED ERROR CODE	No	Optional (7*)
08h	DEVICE RESET	No	Optional (7*)
1xh	RECALIBRATE	Yes	obsoleted(*)
20h	READ SECTOR(S) (w/ retry)	Yes	Mandatory
21h	READ SECTOR(S) (w/o retry)	Yes	Mandatory
22h	READ LONG (w/ retry)	Yes	obsoleted(*)
23h	READ LONG (w/o retry)	Yes	obsoleted(*)
30h	WRITE SECTOR(S) (w/ retry)	Yes	Mandatory
31h	WRITE SECTOR(S) (w/o retry)	Yes	Mandatory
32h	WRITE LONG (w/ retry)	Yes	obsoleted(*)
33h	WRITE LONG (w/o retry)	Yes	obsoleted(*)
38h	CFA TRANSLATE SECTORS W/O ERASE	No	Optional (7*)
3Ch	WRITE VERIFY (2)	Vendor specific	obsoleted(*)
40h	READ VERIFY SECTOR(S) (w/ retry)	Yes	Mandatory
41h	READ VERIFY SECTOR(S) (w/o retry)	Yes	Mandatory
50h	FORMAT TRACK	Yes	obsoleted(*)
7xh	SEEK	Yes	Mandatory
87h	CFA TRANSLATE SECTOR	No	Vendor specific
90h	EXECUTE DEVICE DIAGNOSTIC	Yes	Mandatory
91h	INITIALIZE DEVICE PARAMETERS	Yes	Mandatory
92h	DOWNLOAD MICROCODE	Reserved	Optional
94h-99h	Reserved	Reserved	Reserved(*)
A0h	PACKET	No	Not to be used
A1h	IDENTIFY PACKET DEVICE	No	Not to be used
A2h	SERVICE	No	Not to be used

Figure 115. Command coverage -- continued --

Command Code	Command Name	Implementation for DCXA-2xxxxx	ATA-4 Category
B0h	SMART FUNCTION SET	Yes	Optional – (5)
C0h	CFA ERASE SECTORS	No	Vendor specific
C4h	READ MULTIPLE	Yes	Mandatory
C5h	WRITE MULTIPLE	Yes	Mandatory
C6h	SET MULTIPLE MODE	Yes	Mandatory
C7h	READ DMA QUEUED	No	Optional(*)
C8h	READ DMA (w/ retry)	Yes	Mandatory
C9h	READ DMA (w/o retry)	Yes	Mandatory
CAh	WRITE DMA (w/ retry)	Yes	Mandatory
CBh	WRITE DMA (w/o retry)	Yes	Mandatory
CCh	WRITE DMA QUEUED	No	Optional(*)
CDh	CFA WRITE MULTIPLE W/O ERASE	No	Optional – (7)
DAh	GET MEDIA STATUS	No	Optional (7*)
DEh	MEDIA LOCK	No	Optional (7*)
DFh	MEDIA UNLOCK	No	Optional (7*)
E0h	STANDBY IMMEDIATE	Yes	Mandatory
E1h	IDLE IMMEDIATE	Yes	Mandatory
E2h	STANDBY	Yes	Mandatory
E3h	IDLE	Yes	Mandatory
E4h	READ BUFFER	Yes	Optional
E5h	CHECK POWER MODE	Yes	Mandatory
E6h	SLEEP	Yes	Mandatory
E7h	FLUSH CACHE	Yes	Optional(*)
E8h	WRITE BUFFER	Yes	Optional
ECh	IDENTIFY DEVICE	Yes	Mandatory(*)
EDh	MEDIA EJECT	No	Optional (7*)
EEh	IDENTIFY DEVICE DMA	Yes	obsoleted(*)
EFh	SET FEATURES	Yes	Mandatory
F0h	Vendor specific	Reserved	Vendor specific
F1h	SECURITY SET PASSWORD	Yes	Optional (6)
F2h	SECURITY UNLOCK	Yes	Optional (6)
F3h	SECURITY ERASE PREPARE	Yes	Optional (6)
F4h	SECURITY ERASE UNIT	Yes	Optional (6)
F5h	SECURITY FREEZE LOCK	Yes	Optional (6)
F6h	SECURITY DISABLE PASSWORD	Yes	Optional (6)
F7h	FORMAT UNIT	Vendor specific	Vendor specific
F8h	READ NATIVE MAX ADDRESS	Yes	Optional
F9h	SET MAX ADDRESS	Yes	Optional(*)
FAh–FFh	Vendor specific	Reserved	Vendor specific
—	Reserved: all remaining codes	Reserved	Reserved

Figure 116. Command coverage

- Note:(1) These commands have two command codes and appear in this table twice, once for each command code.
- (2) The WRITE VERIFY command implemented vendor specific. The operation is same as WRITE SECTORS and verification is not performed.
- (3) Protected Area Feature Set
- (4) Power Management Feature Set
- (5) S.M.A.R.T. Function Set
- (6) Security Mode Feature Set
- (7) Removable
- (*) Indicates that the definition of this command has changed from ATA-3, X3.298-1997.

14.2 SET FEATURES Command Support Coverage

The following table is provided to facilitate the understanding of DCXA-2xxxxx "Set Features" command support coverage comparing to the ATA-4 defined command set. The column of 'Implementation' shows the capability of DCXA-2xxxxx for those commands. For detail operation, refer to 12.26, "Set Features (EFh)" on page 140.

Features Register	Features Name	Implementation for DCXA-2xxxxx
02h	Enable write cache	Yes
03h	Set transfer mode	Yes
05h	Enable Advanced Power Management	Yes
09h	Enable Address Offset mode	Yes
44h	Set vendor specific bytes ECC	Yes
55h	Disable read look-ahead feature	Yes
5Dh	Enable release interrupt	No
5Eh	Enable SERVICE interrupt	No
66h	Disable reverting to power on defaults	Yes
82h	Disable write cache	Yes
85h	Disable Advanced Power Management	Yes
89h	Disable Address Offset mode	Yes
95h	Enable Media Status Notification	No
AAh	Enable read look-ahead feature	Yes
BBh	Set 4 bytes ECC	Yes
CCh	Enable reverting to power on defaults	Yes
DDh	Disable release interrupt	No
EEh	Disable SERVICE interrupt	No
others	Reserved	Reserved

Figure 117. SET FEATURES Command coverage

Index

A

- ABRT 63
- ABT 63
- Adaptive Power Management Feature
 - Low Power Idle mode 72
- Advanced Power Management (Adaptive Battery Life Extender 3) Feature 72
- Advanced Power Management Feature
 - Active Idle mode 72
 - Performance Idle mode 72
 - Transition Time 72
- AMN 63
- AMNF 63
- Auto Reassign Function 87
 - Non recovered read errors 87
 - Non recovered write errors 87
 - Recovered read errors 87
- Automatic Power Down Sequence 159

B

- B 98
- BSY 64

C

- Check Power Mode 92, 99
- Command
 - Check Power Mode (E5h/98h) 99
 - Execute Device Diagnostic (90h) 100
 - Flush Cache (E7h) 101
 - Format Track (50h) 102
 - Format Unit (F7h) 104
 - Identify Device (ECh) 106
 - Identify Device DMA (EEh) 112
 - Idle (E3h/97h) 113
 - Idle Immediate (E1h/95h) 114
 - Initialize Device Parameters (91h) 115
 - Read Buffer (E4h) 116
 - Read DMA (C8h/C9h) 117
 - Read Long (22h/23h) 119
 - Read Multiple (C4h) 121
 - Read Native Max Address (F8h) 123
 - Read Sectors (20h/21h) 125
 - Read Verify Sectors (40h/41h) 127
 - Recalibrate (1xh) 129
 - S.M.A.R.T. Function Set (B0h) 146
 - Security Disable Password (F6h) 130
 - Security Erase Prepare (F3h) 131
 - Security Erase Unit (F4h) 132
 - Security Freeze Lock (F5h) 134
 - Security Set Password (F1h) 135
 - Security Unlock (F2h) 137
 - Seek (7xh) 139

Command (continued)

- Set Features (EFh) 140
- Set Max Address (F9h) 142
- Set Multiple (C6h) 144
- Sleep (E6h/99h) 145
- Standby (E2h/96h) 159
- Standby Immediate (E0h/94h) 160
- Write Buffer (E8h) 161
- Write DMA (CAh/CBh) 162
- Write Long (32h/33h) 164
- Write Multiple (C5h) 166
- Write Sectors (30h/31h) 168
- Write Verify (3Ch) 170
- Commands support Coverage 173
- COR 64
- CORR 64

D

- D 98
- DF 64
- Diagnostic
 - Diagnostic and Reset considerations 68
- Diagnostic and Reset considerations 68
- Diagnostic Codes 62, 67, 100
- DRDY 64
- DRQ 64
- DRV 62
- DS0 62
- DS1 61
- DSC 64

E

- ERR 64
- Error Register
 - Diagnostic Codes 67
- Example of operation 82
- Execute Device Diagnostic 92, 100

F

- Flush Cache 92, 101
- Format Track 90, 102
- Format Unit 92, 104

H

- H 98
- H0 61
- H1 61
- H2 61
- H3 61
- HS0 62

HS1 62
HS2 62
HS3 62

I

ICRCE 63
Identify Device 89, 106
Identify Device DMA 93, 112
Idle 92, 113
Idle Immediate 92, 114
IDN 63
IDNF 63
IDX 64
IEN 61
Initial Power Mode at Power On 71
Initialize Device Parameters 92, 115

L

L 62, 98
LBA Addressing Mode 69
Logical CHS Addressing Mode 69

M

Master 62

P

Power Management Feature 70
 Initial Power Mode at Power On 71
 Interface Capability for Power Modes 71
 Power Management Commands 70
 Power Mode 70
 Standby timer 71
 Standby/Sleep command completion timing 70
 Status 71

R

R 98
RDY 64
Read Buffer 89, 116
Read DMA 93, 117
Read Long 89, 119
Read Multiple 89, 121
Read Native Max Address 92, 123
Read Sectors 89, 125
Read Verify Sectors 92, 127
Reassign Function 87
Recalibrate 92, 129
Register
 Alternate Status Register 60
 Command Register 60
 Cylinder High Register 60
 Cylinder Low Register 60
 Data Register 61
 Device Control Register 61

Register (*continued*)

 Device/Head Register 62
 Drive Address Register 61
 Error Register 62
 Features Register 63
 Register Initialization 67
 Sector Count Register 63
 Sector Number Register 63
 Status Register 63
Register Initialization 67
Reset
 Diagnostic and Reset considerations 68
 Register Initialization 67
RST 61

S

S.M.A.R.T. Function 74
 Attribute thresholds 74
 Attribute values 74
 Attributes 74
 S.M.A.R.T. commands 74
 S.M.A.R.T. operation with power management modes 74
 Threshold exceeded condition 74
S.M.A.R.T. Function Set 146
Sector Addressing Mode 69
 LBA Addressing Mode 69
 Logical CHS Addressing Mode 69
Security Disable Password 90, 130
Security Erase Prepare 92, 131
Security Erase Unit 90, 132
Security Freeze Lock 92, 134
Security Mode Feature Set 76
Security Set Password 90, 135
Security Unlock 90, 137
Seek 92, 139
Set Features 92, 140
SET FEATURES Command support Coverage 175
Set Max Address 92, 142
Set Multiple 144
Set Multiple Mode 92
Slave 62
Sleep 92, 145
SMART Disable Operations 92
SMART Enable Operations 92
SMART Enable/Disable Attribute Autosave 92
SMART Execute Off-line Immediate 92
SMART Read Attribute Thresholds 89
SMART Read Attribute Values 89
SMART Return Status 92
SMART Save Attribute Values 92
SRST 61
Standby 92, 159
Standby Immediate 92, 160

T

TON 63
Timeout Interval 61
Timeout Parameter 113, 159
Timeout Values 171
TK0NF 63

U

UNC 63

V

V 98

W

Write Buffer 90, 161
Write Cache 86
Write DMA 93, 162
Write Long 90, 164
Write Multiple 90, 166
Write Sectors 90, 168
Write Verify 91, 170
WTG 61

X

x 98



S25L-2427-02