



Product summary

Ultrastar 36ZX & 18LZX

Multimode SE/LVD



Models: DMVS-09
DMVS-18
DMVS-36

Features

The Ultrastar 36ZX and 18LZX represent IBM's third generation of 10,000 RPM hard disk drives. These Low Voltage Differential (Ultra2 SCSI) drives utilize advanced head load/unload technology and glass substrate disks which prolong drive lifetime through increased durability.

Applications

- Technical/commercial workstations
- Network servers
- Mass storage arrays
- High-end personal computers
- Large scale imaging and graphics
- Video servers
- Video editing

Features

- 36.7GB, 18.3GB, and 9.1GB formatted capacity (512 bytes/sector)
- Industry standard interface
 - 68 pin ANSI SCSI-3
 - 80 pin ANSI SCSI-3
- 14.8 - 28.0MB/sec sustained data transfer rate
- Rotational speed 10,000 RPM
- Average seek time (read) 4.9ms (9&18GB) 5.4ms (36GB)
- Latency 3.0 ms
- 2MB or 8MB multi-segmented cache buffer
- Low command overhead
- Read ahead caching
- ECC on the fly (EOTF)
- No-ID sector formatting
- PRML data channel
- Predictive Failure Analysis (S.M.A.R.T. compliant)

Benefits

- Range of capacities to meet the need for increasing storage requirements
- Fast interface data rates
 - 40MB/sec (Fast 20) & 80MB/sec (Fast 40) data transfer speed
- High data rate across entire disk surface
- Fast access to data
- Fast data retrieval in single and multi-tasking applications
- Improved data throughput
- More data stored per track, increased sustained data transfer rate
- High reliability and availability

Connectors

The electrical connectors are located as shown.

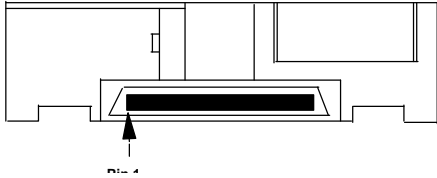

Electrical connectors (rear view) 80 pin SCA models.

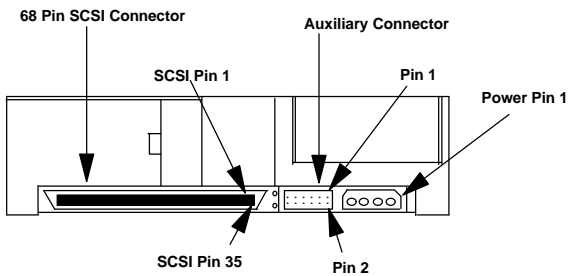

Electrical connectors (rear view) 68 pin models.

The DC power connection is contained in AMP connector p/n 5-917593-9 (80 pin). The power connection in the 68-pin drive requires Molex connector p/n 87360-0001. Pin assignments for the latter are shown below, as viewed from the rear of the drive. Equivalent connectors may be used.

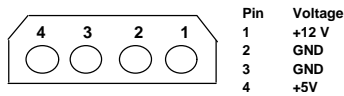

Option Block

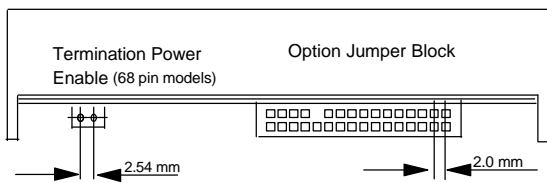

Jumper block locations (front view).

Pitch of jumper pins is 2mm except for the Termination Power Enable pin which has a pitch of 2.54mm.

Jumper Settings

Jumper positions and functions are shown below.

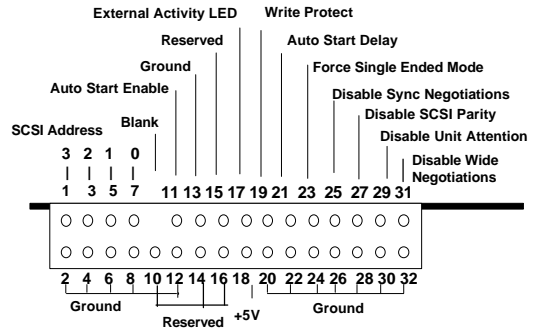

68 pin LVD front jumper block.

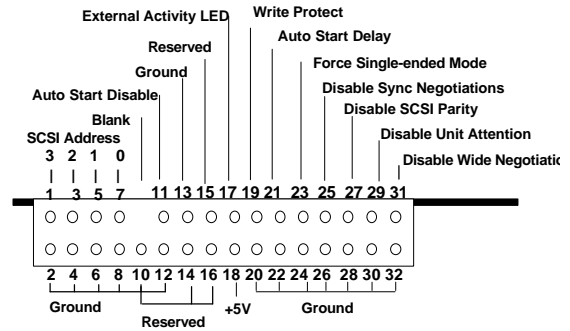

80 pin SCA-2 front option jumper block.

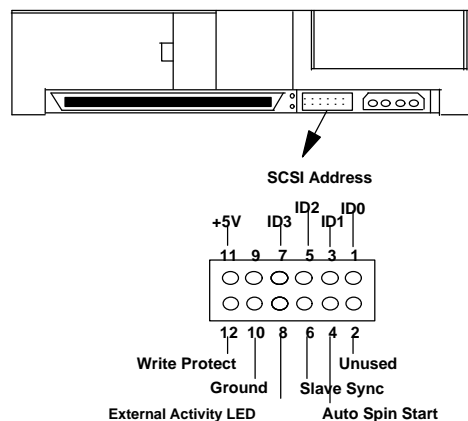

68-pin auxiliary connector

SCSI ID (address) pins

SCSI address bits 3,2,1, and 0 of the Option Jumper Block are used to select the SCSI device ID.

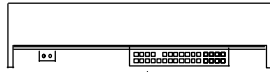

SCSI Address Bits

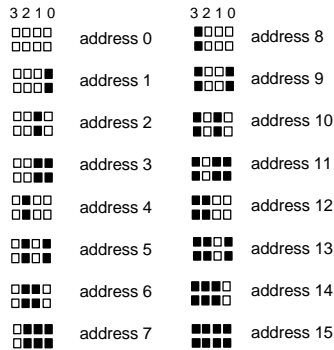

Address 7 is often reserved for the host adapter.

Auto Start and Delay pins

The Auto Start and Auto Start Delay pins control when and how the drive can spin up and come ready. When configured for Auto Start, the motor spins up after power is applied without the need for a SCSI Start Unit command. When the drive is not configured for Auto Startup, a SCSI Start Unit command is required to make the drive spin and be ready for media access operations. When in Auto Start Delay mode, the drive will delay its start time by a period of time multiplied by its own SCSI address.

80 pin model	Drive behavior		
Auto start delay	Auto start enable	Auto startup delay	Delay multiplier
off	off	no	n/a
off	on	yes	0 sec
on	off	yes	10 sec
on	on	yes	4 sec

Auto start delay	Auto start disable	Auto startup delay	Delay multiplier
off	off	yes	0 sec
off	on	no	n/a
on	off	yes	10 sec
on	on	no	n/a

The above tables show Auto Startup Modes that can be selected by Auto Start/Delay pin combinations.

External Activity (LED) pins

The LED pins can be used to drive an external Light Emitting Diode. Please refer to the LED pin section of the Interface Specification for a detailed functional description of this pin, which is controlled by Mode Select (Page 0). Up to 33mA (5%) of TTL level LED drive capability is provided. The electronics card provides current limiting for the LED. The LED Anode may be tied to the +5V source provided on pin 18 of the Front Option Jumper Block, pin 11 of the Auxiliary connector on the 68 pin Unitized connector, or the 5V power source on the 80 pin SCA model. The LED Cathode is then connected to the External Activity pin to complete the circuit.

Note: These drives have two sets of pins, one on the front and one on the back, that are connected to the same LED driver circuit. The combined drive capability is stated above.

Write Protect pin

If the Write Protect pin is jumpered to ground, SCSI commands that alter the customer data area portion of the media will not be performed. The state of this pin is monitored on a per command basis. Refer to the Interface Specification for functional details.

Disable Target Initiated Synchronous Negotiation pin

When a Disable Target Initiated Synchronous Negotiation pin is grounded, an Initiator is required to start a negotiation handshake if Synchronous and/or Wide (double byte) SCSI transfers are desired. Please refer to the Interface Specification for more details on this feature.

Disable SCSI Parity pin

Grounding this pin will disable SCSI Parity Checking.

Disable Unit Attention pin

Grounding this pin will disable the drive from building Unit Attention Sense information for commands immediately following a Power On Reset (POR) or SCSI Bus Reset. Any pending Unit Attention conditions will also be cleared at POR or SCSI Reset times.

Disable Wide Negotiations

Jumpering pins 31 and 32 will cause the drive to operate in a single byte mode. The drive will not negotiate for Wide (double byte) operation.

Enable Termination Power

68 pin models can be jumpered to provide Terminator Power. [This is an optional power source for an external terminator.]

Force Single-Ended Mode

Jumpering pin 23 to pin 24 on LVD models will cause all models to operate in Single-Ended mode only. The drive will not use the DIFFSENS line to determine SE or LVD modes.

Data organization

	9GB	18GB	36GB
Disks	3	5	10
User data heads	5	10	20

Seek times (in milliseconds)

		9GB	18GB	36GB
Single Cylinder	Read	0.4	0.4	0.4
	Write	0.7	0.7	0.7
Average weighted	Read	4.9	4.9	5.4
	Write	5.9	5.9	6.4
Full stroke	Read	10.6	10.6	11.4
	Write	11.4	11.4	12.4

DC power requirement limits

The following voltage specifications apply at the drive power connector. There are no special power on/off sequencing requirements.

+5 volt supply	±5% during run and spin up
+12 volt supply	±5% during run +5 to -7% during spin up

Power supply current

+5VDC	9GB Pop. mean	18GB Pop. mean	36GB Pop. mean
Idle avg	.58A	.58A	.63A
Standby	.54A	.55A	.58A
Start-up	.54A	.55A	.58A

+12 VDC	9GB Pop. mean	18GB Pop. mean	36GB Pop. mean
Idle avg	0.38A	.71A	1.19A
Standby	0.52A	.52A	.82A
Start-up	1.60A	1.60A	2.90A

Externally generated ripple
(as seen at drive power connector)

Voltage	Maximum peak to peak	Frequency
+5V DC	250mV	0-20MHz
+12V DC	650mV	0-100Hz
+12V DC	400mV	100-5000 Hz
+12V DC	250mV	5 KHz-20 MHz

During drive start up and seeking, 12 volt ripple is generated by the drive (referred to as *dynamic loading*). If the power of several drives is daisy chained together, the power supply ripple as well as the dynamic loading of other drives must remain within the regulation tolerance window of ±5%. A more desirable method of power distribution is a common supply with separate power leads to each drive.

Operating environment requirements

The drive operates within its performance limits when the following environment is maintained. Product life calculations are based on the nominal environment for a typical application.

Humidity

Operating	5% to 90% non-condensing
Storage	5% to 90% non-condensing
Shipping	5% to 95% (applies at the packaged level)

Wet Bulb Temperature

Operating	26.7 °C (80 °F) maximum
Shipping/Storage	29.4 °C (85 °F) maximum

Elevation

Operating/Storage	-1000 to 10,000 feet (-304.8 to 3,048 meters)
Shipping	-1,000 to 40,000 feet (-304.8 to 12,192 meters)

Temperature

Operating ambient	5 to 50°C (41 to 122 °F)
Operating disk enclosure	5 to 60 °C (41 to 140 °F)
Storage	1 to 65 °C (34 to 149 °F)
Shipping	-40 to 65 °C (-40 to 149 °F)

Temperature gradient

Operating	20 °C (36 °F) per hour
Shipping/Storage	Below condensation

Total user bytes for various block lengths

User bytes/ logical block	9.1GB	18.2GB	36.7GB
512	9,173,114,880	18,351,959,040	36,703,918,080
514	9,138,663,000	18,283,057,100	36,566,114,200
520	9,063,381,600	18,132,478,000	36,264,956,000
522	9,048,400,200	18,102,432,780	36,204,865,560
524	9,046,346,480	18,098,346,920	36,196,693,840
528	9,085,718,400	18,177,133,920	36,354,267,840
536	9,118,437,360	18,242,658,160	36,485,316,320
688	9,377,508,800	18,760,955,040	37,521,910,080

Hot Plug/Unplug support

The term “Hot Plug” refers to the action of mechanically engaging a device to power and/or to a bus when other devices may be active on the same bus. While every effort was made to design the drive not to influence the SCSI bus during these events, it is a system responsibility to insure voltage regulation and conformance to operational and non-operational shock limits.

During Hot Un-Plug the operational shock limit specifications should not be exceeded. If this cannot be guaranteed then the drive should be issued a SCSI Stop Unit command that is allowed to complete before unplugging. The basic requirement is that while the drive is operational or spinning down the operational shock limits are in effect. The recommended procedure is to allow the unplugged drive to rest in the drive bay for a minimum of 15 seconds and then complete the removal.

During Hot Plug or Unplug events the power supply ripple on adjacent operational drives should not go outside the +/- 5% regulation tolerance.

SCSI bus connectors

68 pin SCSI signal connector

68 pin models use a Molex connector (PN 87360-0001) that is compatible with the ANSI SCSI “P” connector specifications. It can transfer data in both 8 bit (narrow) and 16 bit (wide) modes.

80 pin Single Connector Attachment

80 pin SCA-2 models use an AMP connector (PN 5-917593-9) that is compatible with the specification of “Single Connector Attachment for Small SCSI Disk Drives” SFF-8046 draft document, revision 2.7. It can transfer data in both 8 bit (narrow) and 16 bit (wide) modes.

Note: The SCA-2 connector is not mechanically compatible with the 68 pin “P” connector as defined in the ANSI SCSI standard. This connector is intended for direct backplane attachment and is not intended to be cable attached to the bus.

SCSI bus cable

Low Voltage Differential models permit cable lengths of up to 12 meters (39.4 feet) when operating in LVD mode. Cables must meet the requirements for LVD cables set forth in the Information Technology SCSI Parallel 2 (SPI-2) standard under “Cable Requirements.”

Single-ended models permit cable lengths of up to 6 meters (19.7 feet). It should be noted however, that users who plan to use “Fast” data transfers with single-ended

models should follow all of the ANSI SCSI guidelines for single ended “Fast” operations. This may include a cable length of less than 6 meters.

SCA-2 connector models are not designed for direct cable attachment due to the combination of power and SCSI bus signals. “Fast” data transfers with SCA models should follow all of the ANSI SCSI guidelines for single ended “Fast” operations. The ANSI SCSI standard states that any stub from the main cable must not exceed 0.1 meters for single-ended or LVD cables. The Ultrastar 36ZX family of drives has a maximum internal stub length of 0.06 meters on all LVD and single ended SCSI signals. To remain compliant with the standard, the SCSI bus cable must not add more than 0.05 meters additional stub length to any of the LVD and single-ended SCSI signals.

Models

DMVS model number	GB (at 512 Byte)	SCSI pins	SCSI electrical signal
DMVS-9	9.11	68 SCA-2	SE/LVD multi-mode
DMVS-18	18.35	68 SCA-2	SE/LVD multi-mode
DMVS-36	36.70	68 SCA-2	SE/LVD multi-mode

Start and stop times

9GB, 18GB Models

Time	Nominal	Sigma
Power Up	2.5	0.25
Start-Up	16.5	1.5
Spin-Up	12	2
Coast	45	10
Active Brake	12	3

36GB Models

Time	Nominal	Sigma
Power Up	2.5	0.25
Start-Up	26	1.5
Spin-Up	15	2
Coast	85	10
Active Brake	15	3

All times in seconds.

Bring-up sequence times and stop time

A full Bring-up sequence consists of a Power-up sequence and Start-up sequence as shown below.

“Power On” is defined as when the power at the drive meets all of the power specifications as defined in this document.

The Start-up sequence spins up the spindle motor, initializes the servo subsystem, performs the Basic Assurance Tests 2 (BATS2) verifying the read/write hardware, resumes “Reassign in Progress” operations and more. See the Interface Specification for additional details on the Start-Up sequence. If a SCSI Reset is issued while the drive is in either a Power-Up or Start-Up sequence, that same

sequence starts again. In all other cases when a SCSI Reset is issued the present state of the motor is not altered. A start-up sequence initiated by SCSI “Start/Stop Unit” command that follows a spindle stop initiated by a SCSI “Start/Stop Unit” command by less than 10 seconds may result in the start-up sequence increasing by as much as 10 seconds. For example, if a delay of only 3 seconds exists between the two commands the second command takes 7 seconds longer than if 10 seconds or more had been allowed between commands.

Spin down times

After power is removed, the drive should be allowed 15 seconds to park the heads and spin down before any attempt is made to handle the drive. When power is removed from the drive Active Braking is engaged. If a stop unit command is issued to the drive, the drive coasts to a stop.

It is recommended that after power is removed a period of 2 seconds should be allowed before DC is reapplied to the drive.

In the even of a power glitch the drive will normally issue a Power On Reset and then go through its Power-Up sequence. Depending on the duration of the glitch the drive may spin down and then spin back up or may reset itself in which case the spindle motor is turned off. If the host system detects a power glitch it is recommended that

a reset be issued to all attached drives.



ATTENTION: The drive must be protected against electrostatic discharge especially when being handled. The safest way to avoid damage is to put the drive in an anti-static bag before ESD wrist straps, etc. are removed.

Drives should only be shipped in approved containers. Severe damage can be caused to the drive if the packaging does not adequately protect against the shock levels induced when a box is dropped. Consult your IBM representative if you do not have an approved shipping container.

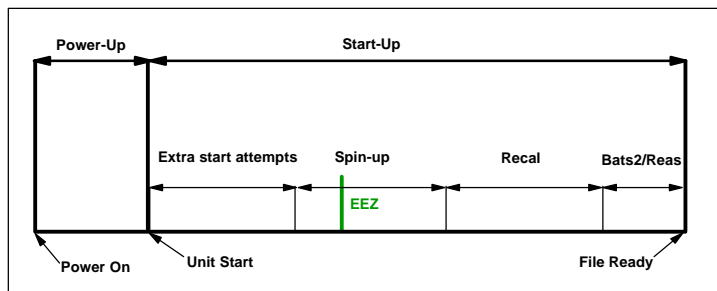

Vibration and shock

Operating/ non-operating vibration

Due to the complexity of this subject, we recommend that users contact the distributor to discuss how to perform the required measurements if they believe this to be an area which requires evaluation.

Operating shock

No permanent damage will occur to the drive when subjected to a 20 G half sine wave shock pulse of 2 milliseconds duration for the 9GB and 18GB models and 10G half sine wave shock pulse of 2 milliseconds duration for the 36GB model.

The shock pulses are applied in each of three mutually perpendicular axes, one axis at a time.

Rotational Shock

The actuator will remain latched on the ramp if the unpackaged drive is subjected to a 2 millisecond half sine wave shock less than 15,000 radians per second squared applied to all three axes, one direction at a time.

Acoustics

Typical A-Weighted	9GB&18GB	36GB
Idle (Bel)	4.09	4.17
Operating (Bel)	5.14	5.28

Clearances

A minimum of 2mm clearance should be given to the bottom surface, with the exception of a 10mm maximum diameter area around the bottom mounting holes.

There should be 7mm of clearance between Ultrastar drives that are mounted with their top sides facing each other. Drives from other manufacturers may require additional spacing due to stray magnetic fields.

Note: For proper cooling it is suggested that a minimum clearance of 7 mm be provided under the drive and on top of the drive.

Mounting

The drive can be mounted with any surface facing down. The drive is available with both side and bottom mounting holes. Refer to the Hardware/Functional Specification for more information. See also diagrams on page 9

The maximum allowable penetration of the mounting screws is 3.8mm. Screws longer than 3.8 mm may cause permanent damage to the drive.

The recommended torque to be applied to the mounting screws is 0.8 Newton-meters +/- 0.2 Newton-meters.

SCA mounting guidelines

Since the SCA mounting system lacks the compliant cabling of alternate connectors the system designer must now consider the following mounting situations and design the system appropriately for long term reliability. This list of guidelines is not intended to be exhaustive.

1. The SCA-2 connector should not be required to support the weight of the drive.
2. Operational vibration occurring between the mating halves of the SCA connector should be avoided.
3. The drive should be firmly secured once the connector mate has occurred.
4. The connector was designed to allow for "mismatch" or offset during plug-in operation. Excessive offsets between the drive connector and the backplane will induce stress on the connector system and card.

Mechanical Specifications

	9GB Model		18GB Model		36GB Model	
	SI Metric	US	SI Metric	US	SI Metric	US
Weight	696 ± 4.5g	1.53 lbs.	713 ± 4.5g	1.57 lbs.	1138 ± 6 g	2.51 lbs.
Height	25.6 mm	1.008 in.	25.6 mm	1.008 in.	42.0 mm	1.63 in.
Width	101.85 mm	4.00 in.	101.85 mm	4.00 in.	101.85 mm	4.00 in.
Depth	147.0 mm	5.75 in.	147.0 mm	5.75 in.	147.0 mm	5.75 in.

Note: Nominal weights and dimensions provided for reference only. Weight tolerance is ±10%.

Outline dimensions and mounting hole locations

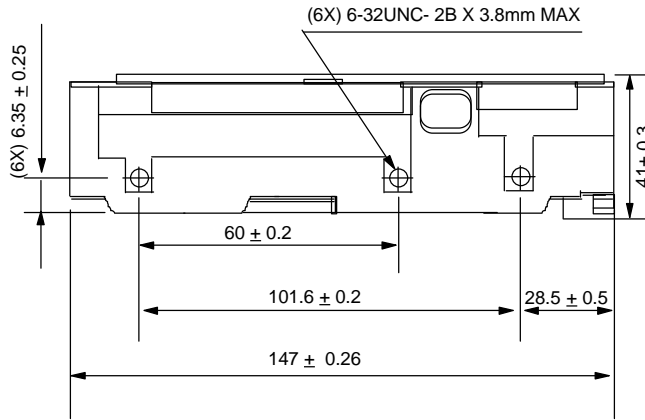

Side mounting holes

All measurements are in millimeters.
Clearance is 7mm.

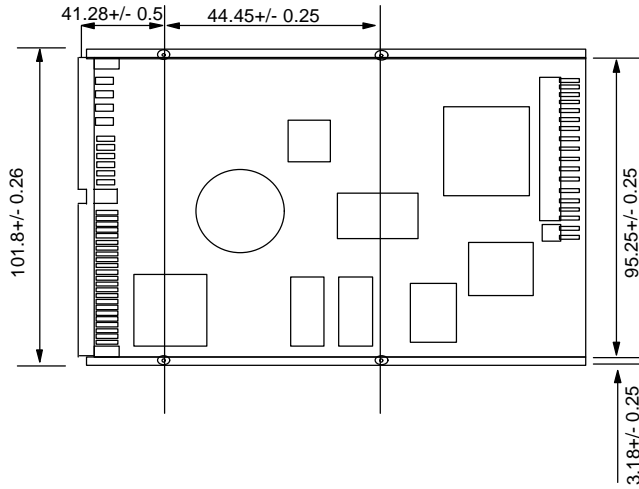

Bottom view

Temperature limitations

Following is a list of measurement points and their temperatures. Maximum temperature must not be exceeded at the worst case drive and system operating conditions with the drive reading and writing at the maximum system operations per second rate.

	Maximum	Optimum
Disk enclosure top	140 °F (60 °C)	122 °F (50 °C)
Disk enclosure bottom	140 °F (60 °C)	122 °F (50 °C)
Channel module ¹	203 °F (95 °C)	167 °F (75 °C)
SCSI module	194 °F (90 °C)	158 °F (70 °C)
Micro-processor module	176 °F (80 °C)	140 °F (60 °C)
Controller module	194 °F (90 °C)	158 °F (70 °C)
Spindle motor driver module	194 °F (90 °C)	158 °F (70 °C)

¹ For continuous read applications, the channel module will run at higher temperatures and will require additional cooling.

Note: Operating the drive above the maximum temperatures may cause permanent damage.

Note: Maximum recommended temperatures are for nominal ambient temperature.

There must be sufficient air flow through the drive so that the casting and module temperature limits are not exceeded.

Module temperature measurement notes

1. Center on the top surface of the module.
2. When making module temperature measurements, if copper tape is used to attach temperature sensors, it should be no larger than 6 mm square.
3. A thermal sensor is fitted to the electronics card. Several temperature thresholds are continuously monitored and the results updated in the drive log. This provides a thermal history and does not interrupt drive operation.

The diagrams below show the location of the modules on the bottom side of the card and the measurement locations on the bottom or top of the casting.

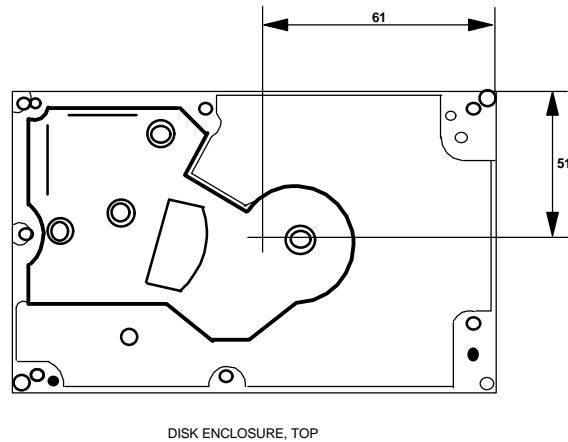
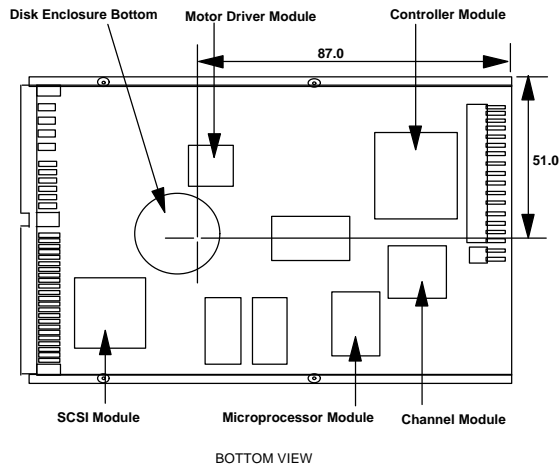



© International Business Machines Corporation 1999

www.ibm.com/harddrive

IBM Hard Disk Drive Technical Support Center
Dept. WCN
3605 Highway 52 North
Rochester, MN 55901
Telephone: 888.IBM.5214 or 507.286.5825
Fax: 507.253.DRIVE
E-mail: drive@us.ibm.com

Singapore Technical Support Center
Telephone: 1800.418.9595 or 65.6.418.9595
E-mail: drive@sg.ibm.com

IBM Storage Systems Division
5600 Cottle Road
San Jose, CA 95193
www.ibm.com/storage

Printed in the United States of America
06-99
All Rights Reserved

IBM, Ultrastar, Drive-TIP, No-ID, and Predictive Failure Analysis are the registered trademarks of International Business Machines Corporation.

AMP is a trademark of AMP Incorporated.
DATA MATE is a trademark of AMP Incorporated.
Molex is a trademark of Molex Incorporated.

Other company, product, and service names may be trademarks or service marks of others.

Produced by the IBM Hard Disk Drive Technical Support Center.

Ultrastar 36ZX, 18LZX, and 9LZX Hardware/Functional Specification, DRAFT version 1.93

This product summary is not a substitute for the full production specification, which should be used when detailed information is required.

Product Description data represents IBM's design objectives and is provided for comparative purposes; actual results may vary based on a variety of factors. This product data does not constitute a warranty. Questions regarding IBM's warranty terms or methodology used to derive this data should be referred to the IBM Hard Disk Drive Technical Support Center. Data subject to change without notice.

Date: 21 October, 1999