



# Travelstar 3LP

## DMCA-21080 and DMCA-21440

The latest 2.5" disk drives from IBM provide up to 1440MB in a slim 12.5mm high package. Using the latest MR head technology, IBM's patented No-ID™ sector formatting, the S.M.A.R.T. function and advanced power saving modes, IBM provides high performance, high capacity drives, particularly suited to the mobile computing market, and its increasing application of multimedia.

### Applications

- High performance portable computers
- Non-IT - process control/fax
- Removable/secure storage units.



Features	Benefits
<ul style="list-style-type: none"> <li>• <b>1080/1440MB at (512 bytes/sector)</b></li> </ul>	<ul style="list-style-type: none"> <li>• High capacity in slim 2.5" form factor</li> </ul>
<ul style="list-style-type: none"> <li>• <b>Enhanced IDE interface with DMA data transfer</b> <ul style="list-style-type: none"> <li>- Single word: mode 2 (8.3MB/sec)</li> <li>- Multi word: mode 2 (16.6MB/sec)</li> </ul> </li> <li>• <b>PIO data transfer - mode 4 (16.6MB/sec)</b></li> </ul>	<ul style="list-style-type: none"> <li>• Popular interface with excellent performance</li> </ul>
<ul style="list-style-type: none"> <li>• <b>Shock 500G (2ms) non-operational</b></li> <li>• <b>Shock 100G (2ms) operational</b></li> </ul>	<ul style="list-style-type: none"> <li>• Robust design for portable computing applications</li> </ul>
<ul style="list-style-type: none"> <li>• <b>Media data rate 39.5-61.3 Mbits/s</b></li> <li>• <b>Rotational speed 4009 rpm</b></li> <li>• <b>Average seek 13 milliseconds (Read)</b></li> </ul>	<ul style="list-style-type: none"> <li>• Excellent data rate across disk surface</li> </ul>
<ul style="list-style-type: none"> <li>• <b>Magneto resistive heads</b></li> </ul>	<ul style="list-style-type: none"> <li>• High areal density, low component count</li> </ul>
<ul style="list-style-type: none"> <li>• <b>No-ID™ sector formatting</b></li> </ul>	<ul style="list-style-type: none"> <li>• More data stored per track, increased sustained data transfer rate</li> </ul>
<ul style="list-style-type: none"> <li>• <b>96KB segmented buffer with write cache</b></li> <li>• <b>Enhanced ECC on the fly</b></li> </ul>	<ul style="list-style-type: none"> <li>• Fast access to data and improved throughput</li> <li>• High reliability</li> </ul>
<ul style="list-style-type: none"> <li>• <b>Advanced power saving modes</b></li> </ul>	<ul style="list-style-type: none"> <li>• Low power for battery powered applications (0.85 watt at idle state)</li> </ul>
<ul style="list-style-type: none"> <li>• <b>Spin up 2.3 sec (typical)</b></li> </ul>	<ul style="list-style-type: none"> <li>• Fast recovery from standby</li> </ul>
<ul style="list-style-type: none"> <li>• <b>S.M.A.R.T. function</b></li> </ul>	<ul style="list-style-type: none"> <li>• Protection of user data</li> </ul>

## Electrical Connector Locations

### Drive Address

Jumper positions are available at the interface connector to determine the drive address.

Using Cable Selection, the drive address depends on the condition of pin 28 of the AT interface cable. In the case when pin 28 is ground or low, the drive is a Master. If pin 28 is open or high level, the drive is a Slave.

## Data Organisation (Logical)

DMCA	21080	21440
Head Number	16	16
Sectors/Track	63	63
Cylinder Number	2100	2800
Sector Size	512	512
Total Customer		
Usable Data Sectors	2,116,800	2,822,400
Total Customer		
Usable Data Bytes	1080MB	1440MB

## DC Power Requirements

Nominal Supply	+ 5 volts
Power Supply Ripple (0-20Mhz) <sup>1</sup>	100mv p-p max
Tolerance <sup>2</sup>	±5%
Supply Current	Pop. Mean (Nominal Condition)
Idle average <sup>3</sup>	< 0.17A RMS Max (0.85W)
Read/Write	< 0.46A RMS Max (2.3W)
Seek average <sup>4</sup>	< 0.46A RMS Max (2.3W)
Standby	< 0.06A RMS Max (0.3W)
Sleep	< 0.02A RMS Max (0.1W)
Start up (max) <sup>5</sup> (average from power on to ready) <sup>6</sup>	< 0.94A RMS Max (4.7W) < 0.70A RMS Max (3.5W)
Supply Rise Time	7 - 100 ms

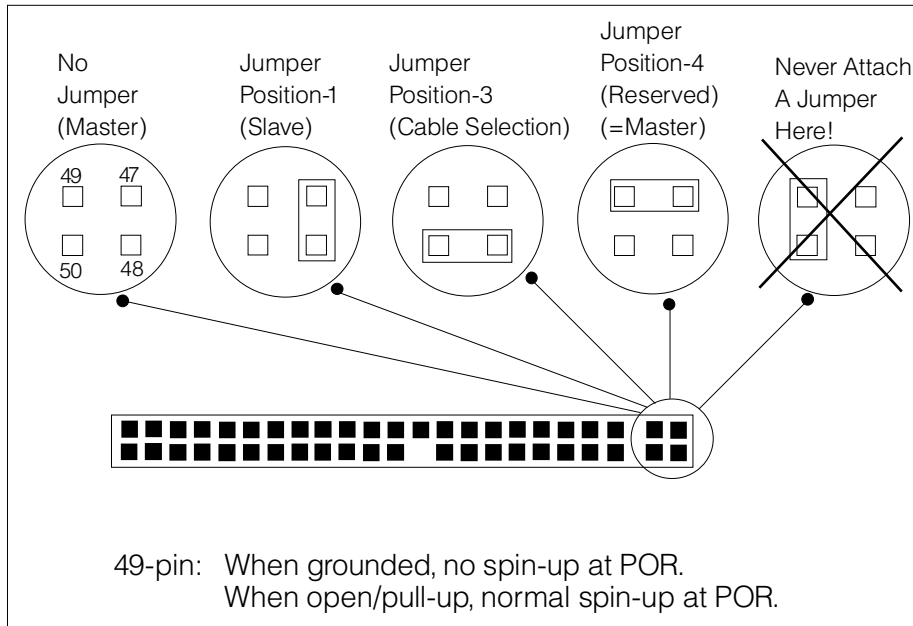

### Notes:

- 1 The maximum supply ripple is measured at 5V input of the HDD.
- 2 The disk drive shall not incur damage for an over voltage condition of +25% (maximum duration of 20 ms) on the 5 volt nominal supply.
- 3 The Idle current is specified at inner track.
- 4 The read/write current is specified based on three operations of 63 sector read/write per 100 msec.
- 5 The seek average current is specified based on three operations per 100 msec.
- 6 The worst case operating current includes motor surge.

### Cabling

The maximum cable length from the host system to the HDD plus circuit pattern in the host system shall not exceed 18 inches.

### AT Signal Connector

The AT signal connector is designed to mate with Dupont part number 69764-044 or equivalent.

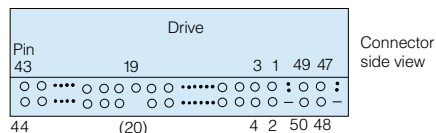

### Note:

- Pin position 20 is left blank for secure connector insertion.



**PACKAGING:** The drive must be protected against Electro-Static Discharge especially when being handled. The safest way to avoid damage is to put the drive in an anti static bag before ESD wrist straps etc are removed.

Drives should only be shipped in approved containers, severe damage can be caused to the drive if the packaging does not adequately protect against the shock levels induced when a box is dropped. Consult your IBM marketing representative if you do not have an approved shipping container.

## Signal Definition

The pin assignments of interface signals are listed as follows:

PIN	Signal	I/O	PIN	Signal	I/O
01	-HRESET	I	02	GND	
03	HDO7	I/O	04	HDO8	I/O
05	HDO6	I/O	06	HDO9	I/O
07	HDO5	I/O	08	HD10	I/O
09	HDO4	I/O	10	HD11	I/O
11	HDO3	I/O	12	HD12	I/O
13	HDO2	I/O	14	HD13	I/O
15	HDO1	I/O	16	HD14	I/O
17	HDO0	I/O	18	HD15	I/O
19	GND		(20)	Key	
21	DMARQ	O	22	GND	
23	-HIOW	I	24	GND	
25	-HIOR	I	26	GND	
27	HIORDY	O	28	CSEL	I
29	-DMACK	I	30	GND	
31	HIRQ	O	32	-HIOCS16	O
33	HAO1	I	34	-PDIAG	I/O
35	HAO0	I	36	HAO2	I
37	-HCSO	I	38	-HCS1	I
39	-DASP	I/O	40	GND	
41	+5V Logic	PWR	42	+5V Motor	PWR
43	GND		44	(Resv)	

### Note:

“O” designates an output from the drive.

“I” designates an input to the drive.

“I/O” designates an input/output common.

“PWR” designates a power supply to the drive.

“(Resv)” designates reserved pins which must be left unconnected.

**Note:** There are two input pins for +5 Volt power supply, “+5V LOGIC” and “+5V MOTOR”. “+5V LOGIC” is connected to the internal logic circuits and “+5V MOTOR” is connected to the spindle motor and motor driver.

It is possible to turn on and off “+5V LOGIC” by an external switch circuit to reduce power consumption to the least possible. In this mode, a voltage drop out due to the motor spin up current can be

reduced by connecting “+5V MOTOR” line into the system power source directly.

If the above power management option is used, all signal lines that will be electrically active in the host system while the HDD is disconnected from power line shall be isolated by Three-State line drivers. Internal leakage through ESD protection circuit may pull down LPUL (Least Positive Up Level) of logic signal below specification.

Use both lines in parallel, for regular HDD applications.

## Command Description

The following Commands are supported by the drive:

Commands	(Hex)	
Check Power Mode	(E5)	3
Check Power Mode*	(98)	3
Disable Password	(F6)	2
Erase Prepare	(F3)	3
Erase Unit	(F4)	2
Executive Device Diagnostic	(90)	3
Format Track	(50)	2
Format Unit	(F7)	3+
Freeze Lock	(F5)	3
Identify Device	(EC)	1
Identify Device DMA	(EE)	4
Idle	(E3)	3
Idle*	(97)	3
Idle Immediate	(E1)	3
Idle Immediate*	(95)	3
Initialize Device Parameters	(91)	3
Read Buffer	(E4)	1
Read DMA (retry)	(C8)	4
Read DMA (no retry)	(C9)	4
Read Long (retry)	(22)	1
Read Long (no retry)	(23)	1
Read Multiple	(C4)	1
Read Native Max LBA/CYL	(F8)	3+
Read Sectors (retry)	(20)	1
Read Sectors (no retry)	(21)	1

Read Verify Sectors (retry)	(40)	3
Read Verify Sectors (no retry)	(41)	3
Recalibrate	(1 X)	3
Seek	(7X)	3
Set Features	(EF)	3
Set Max LBA/CYL	(F9)	3+
Set Multiple Mode	(C6)	3
Set Password	(F1)	2
Sleep	(E6)	3
Sleep*	(99)	3
SMART Disable Operations	(B0)	3
SMART Enable/Disable Attribute Autosave	(B0)	3
SMART Enable Operations	(B0)	3
SMART Execute Off - line Data Collection	(B0)	3
SMART Read Attribute Values	(B0)	1
SMART Read Attribute Thresholds	(B0)	1
SMART Return Status	(B0)	3
SMART Save Attribute Values	(B0)	3
SMART Write Attribute Thresholds	(B0)	2
Standby	(E2)	3
Standby*	(96)	3
Standby Immediate	(E0)	
Standby Immediate	(E0)	3
Standby Immediate*	(94)	3
Unlock	(F2)	2
Write Buffer	(E8)	2
Write DMA (retry)	(CA)	4
Write DMA (no retry)	(CB)	4
Write Long (retry)	(32)	2
Write Long (no retry)	(33)	2
Write Multiple	(C5)	2
Write Sectors (retry)	(30)	2
Write Sectors (no retry)	(31)	2
Write Verify	(3C)	2

### Protocol:

- 1 PIO data IN command
- 2 PIO data OUT command
- 3 Non data command
- 4 DMA command
- + Vendor specific command

\*Alternate Command codes for previous defined commands

---

## Caution

---

### DO NOT PRESS!

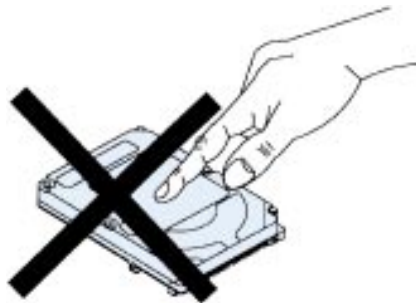

- **Do not press when you take out the drive**
- **Do not press when you carry the drive**
- **Attach the drive free from pressing force.**



*Warning: This disk drive can be damaged by Electro-Static Discharge, please follow recommended ESD*

*procedures before unpacking or handling the drive. Ask your Dealer for details if you need assistance.*

---

## Operating Modes

---

To provide the greatest flexibility of operation with optimum performance and power consumption the drive has a number of operating modes. These are defined below.

### Active Mode

The drive is performing a command, writing cached data to disk or filling a read ahead buffer.

### Performance Idle

The drive is spinning but is not performing a command. It can respond immediately if a new command is received. The transition from active mode to performance idle mode is controlled by the arrival and completion of commands from the host system.

### Low Power Idle

The drive is spinning but is not performing a command. Additionally the drive had determined that the previous command sequence (group of associated commands) is complete. Some of the drive electronics have been powered down but it can still respond to a new command within about 40 milliseconds. The transition from performance idle to low power idle is controlled by IBM's patented Adaptive Battery Life Extension technology.

### Standby

The drive is not spinning and is not performing a command. All electronics except for the command interface is turned off. The transition to standby is controlled by a programmable timer which is set by the host system using standard ATA commands. After receiving a new command, the drive will start spinning again and perform the command within 2 to 3 seconds (typically).

### Sleep

The drive is not spinning and is not performing commands. All of the electronics is turned off. The transition to sleep mode is controlled by a command which is sent by the host system. The transition from sleep can only be triggered by a reset.

---

## Adaptive Battery Life Extension

IBM Travelstar products incorporate software which automatically determines the correct time to start removing power from the drive electronics.

Most software and operating systems make use of a disk drive in bursts. The Travelstar drives monitor the commands which are sent from the host and detect patterns which indicate that a command sequence is active or has completed. The drive can then conserve power after each command sequence is finished by putting the drive into low power idle mode. The result is lower overall power consumption and longer battery life with no loss in performance. If the host system changes the number or frequency of commands which it sends then the disk drive will adapt automatically to this new pattern.

---

## Electromagnetic Compatibility

---

The drive meets the following EMC requirements when installed in a host system and exercised with a random accessing routine at maximum data rate:

United States Federal Communication Commission (FCC) Rules and Regulations Part 15, Subject J - Computer Devices "Class B Limits":

European Economic Community (EEC) directive #76/889 related to the control of radio frequency interference and the Verband Deutscher Elektrotechniker (VDE) requirements of Germany (GOP).

## Operating Environment

### Humidity:

Operating	8% to 90%
Relative	non-condensing
Non-Operating	5% to 95%
Relative	non-condensing

### Wet Bulb Temperature:

#### Maximum Wet Bulb:

Operating	29.4°C
	non-condensing
Non-Operating	40°C
	non-condensing

**Elevation:**

Operating Altitude - 300 to 3048m  
 Non Operating Altitude - 300 to 12000m

**Temperature:**

Operating 5° to 55°C  
 Storage 0° to 65°C  
 Non Operating - 40° to 65°C  
 Temperature Gradient 15°C per hour

**Air Cooling Requirement**

The host system must provide sufficient air flow across the drive to maintain the temperature at less than 60°C (measured at the centre of the files' top cover).

**Operating Shock**

The drive will withstand (with no hard error) a 100G half-sine wave shock pulse of 2ms duration.

**Non-Operating Shock**

The drive will withstand (with no permanent damage or degradation in performance) a 120G half-sine wave shock pulse of 11ms duration or 500G for 2ms.

**Operating and non Operating Vibration**

Due to the complexity of this subject we recommend that users contact the Distributor to discuss how to perform the necessary measurements if they believe this to be an area which requires evaluation.

**S.M.A.R.T. Function**

The intent of self - monitoring, analysis and reporting technology (S.M.A.R.T) is to protect user data and prevent unscheduled system downtime that may be caused by predictable degradation and/or fault of the device. By monitoring and storing critical performance and calibration parameters, S.M.A.R.T devices employ sophisticated data analysis algorithms to predict the likelihood of near - term degradation or fault condition. By alerting the host system of a negative reliability status condition, the host system can warn the user of the impending risk of data loss and advise the user of appropriate action.

Since S.M.A.R.T utilizes the internal device microprocessor and other devices resources, there may be some small overhead associated with its operation. However, special care has been taken in the design of the S.M.A.R.T algorithms to minimize the impact to host system performance. Actual impact of S.M.A.R.T overhead is dependant on the specific device design and the usage patterns of the host system. To further ensure minimal impact to the user, S.M.A.R.T capable devices are shipped from the device manufacturer's factory with the S.M.A.R.T feature disabled. S.M.A.R.T capable devices can be enabled by the system OEMs at time of system integration or in the field by aftermarket products.

**Note:** For further details see drive specification.

**Mechanical Data**

Dimensions	DMCA-21080/21440
Height (mm)	12.5
Width (mm)	69.85
Length (mm)	100.2
Weight (gram)	140/140 Max

**Mounting Orientation**

The drive will operate in all axes (6 directions). The drive will operate within the specified error rates when tilted ±5 degrees from these positions.

Performance and error rate will stay within specification limits if the drive is operated in the other permissible orientations from which it was formatted. Thus a drive formatted in a horizontal orientation will be able to run vertically and vice versa.

The drive must be securely mounted in the system to prevent motion or vibration during a seek operation or spindle rotation using appropriate screws or equivalent mounting hardware.

Vibration and shock tests are to be conducted with the drive mounted to the equipment using the bottom four screw holes.

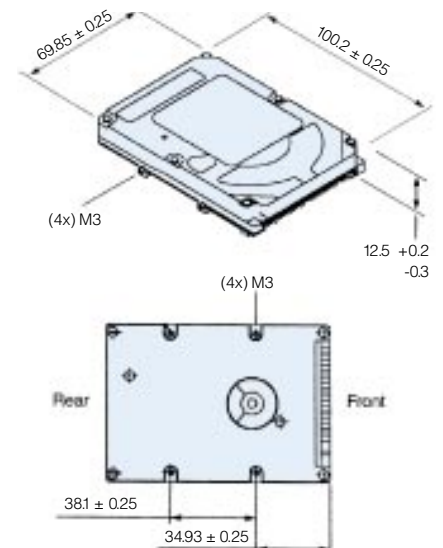

The recommended mounting screw torque is 3 ± 0.5 kgf.cm.

The recommended mounting screw depth is 3.5 ± 0.3mm for bottom and 3.5 ± 0.5mm for horizontal mounting.



**IBM OEM Europe**

PO Box 6  
Langstone Road  
Havant  
Hampshire  
PO91SA  
United Kingdom  
Telephone: (44) 1705 486363

**IBM Corporation**

Storage Systems Division  
5600 Cottle Road  
San Jose, CA 95193  
(408) 256-8000

Japan Headquarters: (81) 466-45-1384

Asia-Pacific Headquarters: (65) 320-1503

Internet access at:

<http://www.storage.ibm.com/storage/oem/menu1.htm>

Registered in England: No. 741598

Registered Office: PO Box 41, North Harbour,  
Portsmouth, Hampshire P06 3AU.

UK company-wide registration to ISO90001.  
Certificate number FM12587.

IBM is the registered trademark of International  
Business Machines Corporation.

AMP is a trademark of AMP Incorporated  
Molex is a trademark of Molex Incorporated  
DATA MATE is a trademark of AMP Incorporated

Other company, product and service names may be  
trademarks or service marks of others.

Produced by the Publishing Service.

© International Business Machines Corporation 1996.

This data sheet is not a substitute for the full  
production specification, which should be used when  
detailed information is required.

Product Description data represents IBM's design  
objectives and is provided for comparative purposes;  
actual results may vary based on a variety of factors.  
This product data does not constitute a warranty.  
Questions regarding IBM's warranty terms or  
methodology used to derive this data should be  
referred to your IBM OEM representative. Data subject  
to change without notice

Date: 1 July 1996

Distributor: