



**DFMS/DFHS SCSI MODELS
ALL CAPACITIES
3.5 INCH DRIVES
SCSI Logical Interface Specification
Release 3.0**

Feb. 20, 1995

Preface

PRODUCT FEATURES

"On the Fly" error correction capabilities	Refer to the product Functional Specification for reliability features
LRC protection for data integrity	Refer to the product Functional Specification for reliability features
Self-optimizing buffer ratios	Refer to 1.6.4, "Page 2 - Disconnect/Reconnect Parameters" on page 91
Variable Block Lengths	Refer to the product Functional Specification
Sector Slipping Defect Management	Refer to 1.16, "Reassign Blocks" on page 133
Optional ANSI SCSI commands supported	Refer to 1.0, "SCSI Commands" on page 21
Command Queuing (both Tagged and Untagged)	Refer to 4.3, "Command Queuing" on page 221
Command Reordering	Refer to 4.3, "Command Queuing" on page 221
Back to Back Writes	Refer to 4.4.1, "Back to Back Writes" on page 225
Write Caching (Volatile)	Refer to 1.6.8, "Page 8h - Caching Parameters" on page 102 regarding the WCE bit
Motor (Spindle) Synchronization	Refer to 4.5, "Motor Synchronization" on page 225
Automatic Rewrite/Reallocate	Refer to 4.7, "Automatic Rewrite/Reallocate - Recommend Rewrite/Reassign" on page 228
Automatic Recommend Rewrite/Reallocate	Refer to 4.7, "Automatic Rewrite/Reallocate - Recommend Rewrite/Reassign" on page 228
Predictive Failure Analysis™ (PFA™)	Refer to 4.8, "Predictive Failure Analysis" on page 230
Segmented Caching	Refer to 4.9, "Segmented Caching" on page 231
Read Ahead support	Refer to 4.9.3, "Read-Ahead" on page 231
Down-loadable SCSI Firmware	Refer to 1.34, "Write Buffer" on page 160
LED support	Refer to 4.16, "LED Pin" on page 241

Basic Assurance Tests	Refer to 4.19, “Basic Assurance Tests (BATS)” on page 244
Full 32 byte SCSI Sense Data Format	Refer to Appendix A, “SCSI Sense Data Format” on page 247
Synchronous/wide data transfer support	Refer to 3.1, “Supported Messages” on page 167 and 1.6.2, “Page 0 - Vendor Unique Parameters” on page 75
Performance counter information via Log Sense	Refer to 1.5, “Log Sense” on page 52
Selectable reporting of Errors (QPE etc.)	Refer to 1.6.2, “Page 0 - Vendor Unique Parameters” on page 75
Multiple Initiator Support	Refer to 4.14, “Multiple Initiator Systems” on page 240

About This Manual

This manual is a description of the Small Computer System Interface (SCSI) function supported by the Drive.

The first three chapters cover SCSI commands, status, and messages.

Chapter 4 covers behavior under various operating conditions.

The Appendices cover sense data and error recovery.

For elements of SCSI not described in this document (that is, physical characteristics, bus phases), refer to the *Small Computer System Interface-2 (SCSI-2)*.

For non-SCSI characteristics of this Drive such as physical dimensions, power requirements, and performance, refer to the product Functional Specification.

Every attempt has been made to make this Drive compliant with the current draft definition of the *Small Computer System Interface (SCSI-2)* Version-10h, dated 17 October 1991. The intent is to comply with the final SCSI-2 specification when that standard is adopted.

SCSI-2 by design provides compatibility with SCSI devices that support bus parity and meet conformance level 2 of the American National Standard X3.131-199X. Accordingly, this Drive can coexist with earlier SCSI devices on the same bus. The Drive also operates well even when the Initiator does not support the SCSI-2 protocol extensions.

Note: This Document was printed from an on-line system and must only be used for reference purposes.

- The Master document is the on-line version, STARSCSO LIST3820 on an IDSS doc disk on RCHVMX.
- To preserve the integrity of this document please DO NOT remove any pages from this printed copy.
- The individual who receives a copy of this document is responsible for prompt disposal of the copy when it is superseded by a newer version of the document or by another document.
- If this document is received by other means than from the Development group, the individual who received this document is required to report to Development. Failure to do so prevents Development from informing the individual of future releases.

APPROVALS

This document has been approved by:

Dept. 41L Manager, Ken Plummer 2/20/95

REVIEW PROCEDURES

The content of this specification is directly tied to the current microcode (firmware) release. Therefore, this document is reviewed when new levels of microcode are about to be released.

The next scheduled release will be on hold until a new level of microcode is announced.

Data Representation

This document uses ASCII notation. Hex values are indicated by a trailing 'h'. Binary values are indicated by a trailing 'b'. The following notations are equivalent:

- 07h or 07H
- '07'x or '07'X
- 0x07 (except in the case where "x" is defined as "don't care")

In ASCII, the high order bit in a byte is seven, the low order bit is zero.

Revision History

07/12/93	Initial release (preliminary). Major changes from Release 1.0 Spitfire.
12/07/93	Preliminary release after internal review.
01/07/94	Second release.
01/24/94	Third release. Corrected revision year to 1994. Removed UQE from Mode Select and queueing section.
06/09/94	Fourth release changes.
09/15/94	Fifth release changes. (Release 2.0)
02/20/95	Sixth release (Release 3.0) changes are marked with change bars. " "

Contents

1.0 SCSI Commands	21
1.1.1 CDB Control Byte	22
1.1.2 Reserved field definitions	22
1.1.3 Reserved value definitions	22
1.1.4 Invalid field Errors	22
1.2 Format Unit	23
1.3 Inquiry	30
1.3.1 Inquiry Data Format - EVPD = 0	32
1.3.2 Inquiry Data Format EVPD = 1 - Page Code = 00	35
1.3.3 Inquiry Data Format - EVPD = 1 - Page Code = 01	36
1.3.4 Inquiry Data Format - EVPD = 1 - Page Code = 02	38
1.3.5 Inquiry Data Format - EVPD = 1 - Page Code = 03	40
1.3.6 Inquiry Data Format - EVPD = 1 - Page Code = 80	41
1.3.7 Inquiry Data Format - EVPD = 1 - Page Code = 82	42
1.4 Log Select	44
1.4.1 Log Select Page 01h	47
1.4.2 Log Select Page 02h	48
1.4.3 Log Select Page 03h	49
1.4.4 Log Select Page 05h	50
1.4.5 Log Select Page 06h	51
1.5 Log Sense	52
1.5.1 Log Page Parameters	54
1.5.2 Log Sense Page 00h	54
1.5.3 Log Sense Page 01h	56
1.5.4 Log Sense Page 02h	57
1.5.5 Log Sense Page 03h	58
1.5.6 Log Sense Page 05h	60
1.5.7 Log Sense Page 06h	61
1.5.8 Log Sense Page 30h	62
1.5.9 Log Sense Page 32h	65
1.5.10 Log Sense Page 33h	67
1.5.11 Log Sense Page 35h	69
1.6 Mode Select (6)	70
1.6.2 Page 0 - Vendor Unique Parameters	75
1.6.3 Page 1 - Error Recovery Parameters	83
1.6.4 Page 2 - Disconnect/Reconnect Parameters	91
1.6.5 Page 3 - Format Device Parameters	94
1.6.6 Page 4h - Rigid Disk Drive Geometry Parameters	97
1.6.7 Page 7h - Error Recovery Parameters for Verify	100
1.6.8 Page 8h - Caching Parameters	102
1.6.9 Page 0Ah - Control Mode Parameters	105
1.6.10 Page 0Ch - Notch Parameters	107
1.7 Mode Sense (6)	109
1.7.1 Mode Sense Data Format (of Header & Block Descriptor)	111
1.7.2 Mode Sense Data Format (of All Pages)	113
1.8 Pre-Fetch	119
1.9 Read (6)	121
1.10 Read (10)	122
1.11 Read Buffer	123
1.12 Read Capacity	125
1.13 Read Defect Data (10)	126

1.14	Read Defect Data (12)	129
1.15	Read Long	132
1.16	Reassign Blocks	133
1.17	Receive Diagnostic Results	135
1.17.1	Supported Diagnostic Pages - Receive Diagnostics	135
1.17.2	Translate Address Page - Receive Diagnostics	135
1.18	Release (6)	137
1.19	Release (10)	138
1.20	Request Sense	139
1.21	Reserve (6)	141
1.22	Reserve (10)	142
1.23	Rezero Unit	144
1.24	Seek (6)	145
1.25	Seek (10)	145
1.26	Send Diagnostic	146
1.26.1	Send Diagnostics Page 00h	148
1.26.2	Send Diagnostics Page 40h	148
1.27	Start/Stop Unit	150
1.28	Synchronize Cache	152
1.29	Test Unit Ready	153
1.30	Verify	154
1.31	Write (6)	156
1.32	Write (10)	157
1.33	Write and Verify	158
1.34	Write Buffer	160
1.35	Write Long	163
1.36	Write Same	164
2.0	SCSI Status Byte	165
3.0	SCSI Message System	167
3.1	Supported Messages	167
3.1.1	Command Complete (00h)	168
3.1.2	Save Data Pointer (02h)	168
3.1.3	Restore Pointers (03h)	168
3.1.4	Disconnect (04h)	169
3.1.5	Initiator Detected Error (05h)	169
3.1.6	Abort (06h)	169
3.1.7	Message Reject (07h)	170
3.1.8	No Operation (08h)	170
3.1.9	Message Parity Error (09h)	170
3.1.10	Linked Command Complete (0Ah)	170
3.1.11	Linked Command Complete with Flag (0Bh)	171
3.1.12	Bus Device Reset (0Ch)	171
3.1.13	Abort Tag (0Dh)	171
3.1.14	Clear Queue (0Eh)	171
3.1.15	Continue I/O Process (12h)	172
3.1.16	Target Transfer Disable (13h)	172
3.1.17	Queue Tag Messages (20h, 21h, 22h)	173
3.1.18	Ignore Wide Residue (23h)	174
3.1.19	Identify (80h or C0h)	174
3.1.20	Extended Messages (01h,xxh)	175
3.1.21	Synchronous Data Transfer Request (01h,01h)	175
3.1.22	Wide Data Transfer Request (01h,03h)	179
3.2	Supported Message Functions	181

3.3	Attention Condition	182
3.4	SCSI Bus Parity Error Detection	185
3.5	Message State/Action Table	186
3.6	SCSI Bus Related Error Handling Protocol	192
3.6.1	Unexpected Bus Free Phase Error Condition	192
3.6.2	Message Out Phase Retry	193
3.6.3	Message In Phase Retry	194
3.6.4	Command Phase Retry	194
3.6.5	Status Phase Retry	195
3.6.6	Data Out Phase Retry	195
3.6.7	Data In Phase Retry	195
3.6.8	Identify Message In Phase Retry	196
3.6.9	Simple Queue Tag Message In Phase Retry	196
4.0	Additional Information	197
4.1	SCSI Protocol	197
4.1.1	Priority of SCSI Status Byte Reporting	197
4.1.2	Invalid LUN Processing	198
4.1.3	Incorrect Initiator Connection	199
4.1.4	Command Processing During Execution of Active I/O Process	200
4.1.5	Unit Attention Condition	202
4.1.6	Command Processing During Start-up and Format Operations	205
4.1.7	Internal Error Condition	206
4.1.8	Deferred Error Condition	207
4.1.9	Degraded Mode	208
4.1.10	Command Processing While Reserved	219
4.2	Priority Commands	220
4.3	Command Queuing	221
4.3.1	Untagged Queuing	221
4.3.2	Tagged Queuing	222
4.3.3	Queue Full	222
4.3.4	Rules for Queuing commands	223
4.3.5	Effects of errors on Command Queuing	223
4.3.6	Termination of I/O processes	224
4.4	Concurrent Command Processing	224
4.4.1	Back to Back Writes	225
4.5	Motor Synchronization	225
4.6	Error Logs	228
4.7	Automatic Rewrite/Reallocate - Recommend Rewrite/Reassign	228
4.8	Predictive Failure Analysis	230
4.9	Segmented Caching	231
4.9.1	Overview	231
4.9.2	Options Supported	231
4.9.3	Read-Ahead	231
4.9.4	Write Cache	235
4.9.5	Synchronize Cache on SCSI Reset	236
4.9.6	Segment Selection	236
4.9.7	Segment Prioritization	237
4.10	Reselection Timeout	239
4.11	Single Initiator Selection	239
4.12	Non-arbitrating Systems	239
4.13	Selection without ATN	239
4.14	Multiple Initiator Systems	240
4.14.1	Initiator Sense Data	240
4.14.2	Initiator Mode Select/Mode Sense Parameters	240

4.14.3 Initiator Data Transfer Mode Parameters	240
4.15 Options Jumper Block	241
4.16 LED Pin	241
4.17 Reset	242
4.17.1 Reset Sources	242
4.17.2 Reset Actions	242
4.18 Bring-Up Sequence	243
4.19 Basic Assurance Tests (BATS)	244
4.19.1 BATS1 Tests	244
4.19.2 BATS2 Tests	244
4.20 Reserved Area	245
Appendix A. SCSI Sense Data Format	247
A.1.1 Sense Data Description	248
Appendix B. Recovery Procedures	273
B.1 Data Recovery Procedure for Data Field Errors	273
B.1.1 Read Commands	274
B.1.2 Verify Commands	275
B.1.3 Write Commands (No Sector Found)	277
B.2 Error Recovery for Non-Data Errors	277
B.2.1 Position Error (Servo Error Recovery)	277
B.2.2 Drive Fault	277
B.2.3 Spindle Motor Error	278
B.2.4 Spindle Synchronization Error	278
B.3 Priority of Error Reporting	278
Appendix C. Recommended Initiator Error Recovery Procedures	279
C.1 Drive service strategy	279
C.2 Recommendations for System Error Log	280
C.3 Data Recovery Procedure	280
C.3.1 Rewrite an LBA	281
C.3.2 Reassign a physical sector	282
C.3.3 Data error logging	283
C.3.4 Reassign Blocks Recovery	284
C.4 Non-Data Error Recovery Procedure	284
C.4.1 Drive busy	284
C.4.2 Unrecovered drive error	285
C.4.3 Recovered drive error	285
C.4.4 Drive not ready	285
C.4.5 No defect spare	285
C.4.6 Degraded Mode	286
C.4.7 Reserved Area Hard Error	287
C.4.8 Interface Protocol	287
C.4.9 Aborted Command	288
C.4.10 Unit Attention	289
C.4.11 Components Mismatch	290
C.4.12 Self Initiated Reset	291
C.4.13 Defect List Recovery	292
C.4.14 Miscompare recovery	292
C.4.15 Microcode error	293
C.4.16 Predictive failure analysis	294
Appendix D. UEC List	295

Glossary	303
Index	305

Figures

1. Attention Condition during Asynchronous Information Transfer phase	183
2. Attention Condition during Synchronous Data Transfer phase	184

Tables

1.	SCSI Commands Supported	21
2.	Format Unit Command Descriptor Block	23
3.	Format of Defect List - Header	25
4.	Format of Defect List - Descriptor(s)	25
5.	Effect of Options on Format operations	27
6.	Defect Descriptor - Bytes From Index format	28
7.	Defect Descriptor - Physical Sector Format	28
8.	Inquiry Command Descriptor Block	30
9.	Standard Inquiry Data - EVPD = 0	32
10.	Inquiry data - EVPD = 1 - Page Code = 00	35
11.	Inquiry data - EVPD = 1 - Page Code = 01	36
12.	Inquiry data - EVPD = 1 - Page Code = 02	38
13.	Inquiry data - EVPD = 1 - Page Code = 03	40
14.	Inquiry data - EVPD = 1 - Page Code = 80	41
15.	Inquiry data - EVPD = 1 - Page Code = 82	42
16.	Log Select Command Descriptor Block	44
17.	Log Select Page 01h	47
18.	Log Select Page 01h Parameter Code 0000h	47
19.	Log Select Page 01h Parameter Code 0001h	47
20.	Log Select Page 02h	48
21.	Log Select Page 02h - Parameter Code 0002h	48
22.	Log Select Page 02h - Parameter Code 0003h	48
23.	Log Select Page 02h - Parameter Code 0006h	48
24.	Log Select Page 02h - Parameter Code 8000h	48
25.	Log Select Page 02h - Parameter Code 8001h	49
26.	Log Select Page 03h	49
27.	Log Select Page 03h - Parameter Code 0000h	49
28.	Log Select Page 03h - Parameter Code 0002h	49
29.	Log Select Page 03h - Parameter Code 0003h	49
30.	Log Select Page 03h - Parameter Code 0006h	50
31.	Log Select Page 03h - Parameter Code 8000h	50
32.	Log Select Page 03h - Parameter Code 8002h	50
33.	Log Select Page 05h	50
34.	Log Sense Page 05h - Parameter Code 0000h	50
35.	Log Select Page 05h - Parameter Code 0002h	51
36.	Log Select Page 05h - Parameter Code 0003h	51
37.	Log Select Page 05h - Parameter Code 0006h	51
38.	Log Select Page 06h	51
39.	Log Sense Command Descriptor Block	52
40.	Log Sense Page 00h	55
41.	Log Sense Page 01h	56
42.	Log Sense Page 01h Parameter Code 0000h	56
43.	Log Sense Page 01h Parameter Code 0001h	56
44.	Log Sense Page 02h	57
45.	Log Sense Page 02h - Parameter Code 0002h	57
46.	Log Sense Page 02h - Parameter Code 0003h	57
47.	Log Sense Page 02h - Parameter Code 0006h	57
48.	Log Sense Page 02h - Parameter Code 8000h	58
49.	Log Sense Page 02h - Parameter Code 8001h	58
50.	Log Sense Page 03h	58
51.	Log Sense Page 03h - Parameter Code 0000h	58

52.	Log Sense Page 03h - Parameter Code 0002h	59
53.	Log Sense Page 03h - Parameter Code 0003h	59
54.	Log Sense Page 03h - Parameter Code 0006h	59
55.	Log Sense Page 03h - Parameter Code 8000h	59
56.	Log Sense Page 03h - Parameter Code 8002h	60
57.	Log Sense Page 05h	60
58.	Log Sense Page 05h - Parameter Code 0000h	60
59.	Log Sense Page 05h - Parameter Code 0002h	60
60.	Log Sense Page 05h - Parameter Code 0003h	61
61.	Log Sense Page 05h - Parameter Code 0006h	61
62.	Log Sense Page 06h	61
63.	Log Sense Page 30h	62
64.	Log Sense Page 32h	65
65.	Log Parameter Format - Page 32h	66
66.	Log Sense Page 33h	67
67.	Log Parameter Format - Page 33h	67
68.	Log Sense Page 35h	69
69.	Mode Select Command Descriptor Block	70
70.	Mode Select Parameter List - Header	72
71.	Mode Select Parameter List - Block Descriptor	73
72.	Mode Select Parameter List - Page Descriptor(s)	74
73.	Mode Select Data Format Page 0	75
74.		78
75.	Mode Select Data Format Page 1	83
76.	Mode Select Data Format Page 2	91
77.	Mode Select Data Format Page 3	94
78.	Mode Select Data Format Page 4h	97
79.	SCSI/ESDI Synchronized Spindle Modes for 50 and 68 pin connectors	98
80.	Mode Select Data Format Page 7h	100
81.	Mode Select Data Format Page 8h	102
82.	Mode Select Data Format Page 0Ah	105
83.	Mode Select Data Format Page 0Ch	107
84.	Mode Sense Command Descriptor Block	109
85.	Mode Sense Data Format - Header	111
86.	Mode Sense Data Format - Block Descriptor	111
87.	Mode Sense Data Page 00h	113
88.	Mode Sense Data Page 01h	113
89.	Mode Sense Data Page 02h	114
90.	Mode Sense Data Page 03h	115
91.	Mode Sense Data Page 04h	116
92.	Mode Sense Data Page 07h	116
93.	Mode Sense Data Page 08h	117
94.	Mode Sense Data Page 0Ah	117
95.	Mode Sense Data Format Page 0Ch	118
96.	Pre-Fetch Command Descriptor Block	119
97.	Read (6) Command Descriptor Block	121
98.	Read (10) Command Descriptor Block	122
99.	Read Buffer Command Descriptor Block	123
100.	Read Capacity Command Descriptor Block	125
101.	Format of Read Capacity Data Returned	125
102.	Read Defect Data Command Descriptor Block	126
103.	Read Defect Data - Header	127
104.	Read Defect Data - Defect Descriptor(s)	127
105.	Defect Descriptor - Bytes From Index Format	128
106.	Defect Descriptor - Physical Sector Format	128

107. Read Defect Data Command Descriptor Block	129
108. Read Defect Data - Header	130
109. Read Defect Data - Defect Descriptor(s)	130
110. Defect Descriptor - Bytes From Index Format	131
111. Defect Descriptor - Physical Sector Format	131
112. Read Long Command Descriptor Block	132
113. Reassign Blocks Command Descriptor Block	133
114. Format of Reassign Blocks Data - Header	134
115. Format of Reassign Blocks Data - Descriptor(s)	134
116. Format of Reassign Blocks Data - Descriptor	134
117. Receive Diagnostic Results Command Descriptor Block	135
118. Supported Diagnostic Pages - Receive Diagnostics	135
119. Translate Address Page - Receive Diagnostics	136
120. Release Command Descriptor Block	137
121. Release Command Descriptor Block	138
122. Request Sense Command Descriptor Block	139
123. Reserve Command Descriptor Block	141
124. Reserve Command Descriptor Block	142
125. Rezero Unit Command Descriptor Block	144
126. Seek (6) Command Descriptor Block	145
127. Seek (10) Command Descriptor Block	145
128. Send Diagnostic Command Descriptor Block	146
129. Supported Diagnostics Pages - Send Diagnostics	148
130. Translate Address Page - Send Diagnostics	148
131. Start/Stop Unit Command Descriptor Block	150
132. Synchronize Cache Command Descriptor Block	152
133. Test Unit Ready Command Descriptor Block	153
134. Verify Command Descriptor Block	154
135. Write (6) Command Descriptor Block	156
136. Write (10) Command Descriptor Block	157
137. Write and Verify Command Descriptor Block	158
138. Write Buffer Command Descriptor Block	160
139. Write Long Command Descriptor Block	163
140. Write Same Command Descriptor Block	164
141. SCSI Status Byte	165
142. Status Code Bit Definitions	165
143. Supported One-Byte Messages	167
144. Supported Two-Byte Messages	167
145. Supported Multiple-Byte Messages	168
146. Queue Tag Messages	173
147. Ignore Wide Residue Message Format	174
148. Extended Message Format	175
149. Synchronous Data Transfer Request Message Definition	176
150. Initiator Request/Target Response	176
151. Target Response to Initiator's Transfer Period	178
152. Wide Data Transfer Request Message Definition	179
153. Initiator Request/Target Response	180
154. Target Response to Initiator's Transfer Period	181
155. Action Table Example	187
156. Message Action Legend	188
157. Message State/Action Table (Part 1)	189
158. Message State/Action Table (Part 2)	190
159. Message State/Action Table (Part 3)	191
160. Auto/Recommend Rewrite/Reallocate Sense data combinations.	230
161. Format of Sense Data	247

162. Valid Sense Key, Code, Qualifier Combinations used by the drive. . . .	250
163. Actual Retry Count Bytes	269
164. Progress Indication Bytes	269
165. Field Pointer Bytes	270
166. Read Recovery Steps	274
167. Write and Verify Recovery Steps	276
168. Verify Recovery Steps	276
169. Write Recovery Steps	277
170. Servo Error Recovery Steps	277
171. Drive Fault Recovery Steps	277
172. Recommend Rewrite errors	281
173. Recommend Reassign errors	282
174. Log Only errors	283
175. Unit Error Codes with Descriptions.	295

1.0 SCSI Commands

Following is a summary of SCSI commands supported. The column “SCSI” refers to revision 10h of the ANSI version 2 standard.

Table 1. SCSI Commands Supported		
SCSI	Code	Description
M	04h	Format Unit
M	12h	Inquiry
O	4Ch	Log Select
O	4Dh	Log Sense
O	15h	Mode Select (6)*
O	1Ah	Mode Sense (6)*
O	34h	Pre-Fetch
M	08h	Read (6)*
M	28h	Read (10)*
O	3Ch	Read Buffer
M	25h	Read Capacity
O	37h	Read Defect Data (10)*
O	B7h	Read Defect Data (12)*
O	3Eh	Read Long
O	07h	Reassign Blocks
O	1Ch	Receive Diagnostic Results
M	17h	Release
O	57h	Release (10)*
M	03h	Request Sense
M	16h	Reserve
O	56h	Reserve (10)*
O	01h	Rezero Unit
O	0Bh	Seek (6)*
O	2Bh	Seek (10)*
M	1Dh	Send Diagnostic
O	1Bh	Start/Stop Unit
O	35h	Synchronize Cache
M	00h	Test Unit Ready
O	2Fh	Verify
O	0Ah	Write (6)*
O	2Ah	Write (10)*
O	2Eh	Write and Verify
O	3Bh	Write Buffer
O	3Fh	Write Long
O	41h	Write Same

M - Mandatory
O - Optional
V - Vendor Unique
* Command Descriptor Block Length

1.1.1 CDB Control Byte

These bits are in the control byte, which is the last byte of every command descriptor block. The meanings of these fields are defined below.

- VU VU stands for Vendor Unique.
- Flag If Link is zero, Flag must also be zero. If Link is one and the command terminates successfully, the Target sends either the Linked Command Complete message (Flag=0) or the Linked Command Complete (With Flag) message (Flag=1). Typically this bit is used to cause an interrupt in the Initiator between linked commands.
- Link This bit is set to one to indicate that the Initiator desires an automatic link to the next command upon successful completion of the current command. Upon successful completion of the command, the Drive returns Intermediate status and then sends one of the two messages defined under Flag above.

1.1.2 Reserved field definitions

A Reserved field is defined as being required to be filled with binary 0. It may be shown in tables as any of the following:

- Reserved
- Reserved = 0
- RSVD
- RSVD = 0

1.1.3 Reserved value definitions

A value may be defined to be 'Reserved'. This means that the value is not valid for the field being described.

1.1.4 Invalid field Errors

If a value is invalid in one of the Command Descriptor Blocks, a *Check Condition Status* will result with a sense key of ***Illegal Request*** and additional sense code/qualifier dependent upon which field was invalid. The following are self explanatory:

- ***Invalid Command Operation Code***
- ***Logical Block Address out of Range***
- ***Logical Unit Not Supported***

Invalid Field in CDB is used for fields other than the above.

Invalid Field in Parameter List is used for invalid fields in parameter data.

Invalid Bits in Identify Message is used when the Reserved bits in a message are non-zero.

1.2 Format Unit

Table 2. Format Unit Command Descriptor Block								
Byte	BIT							
	7	6	5	4	3	2	1	0
0	Operation Code = 04h							
1	LUN			FmtData	CmpLst	Defect List Format		
2	Vendor Unique = 0							
3	(MSB)Interleave Factor (LSB)							
4								
5	VU = 0		Reserved = 0			Flag	Link	

The Format Unit command performs a physical formatting of the Drive. This includes a rewrite of all the sector IDs, handling of defective sectors, and the overwriting of all data areas with binary zeros. The formatting process includes a verification of access positioning only and does not include a verification of ID or data fields.

The Drive manages two internal defect lists and one external. The primary defect list (PList) is created at time of manufacture and cannot be altered. The grown defect list (GList) is built after time of manufacture by the Initiators use of the Reassign Blocks command and the Automatic Reallocate function(see 4.7, “Automatic Rewrite/Reallocate - Recommend Rewrite/Reassign” on page 228). The data defect list (DList) is an external list, it is supplied by the initiator in the DATA OUT phase of the Format Unit command.

Several options for managing the GList are supported.

FmtData set to one specifies that a Data Out phase follows the Command phase. The Data Out phase consists of a defect list header followed by zero or more defect descriptors (see Table 3 on page 25 and Table 4 on page 25).

FmtData set to zero specifies that no Data Out phase follows.

CmpLst set to one specifies that the GList existing prior to the format not be used and is discarded. The Drive is formatted with the PList and DList(if specified). The DList becomes the new GList.

CmpLst set to zero specifies that the GList existing prior to the format be used. The Drive is formatted with the PList, the GList, and the DList (if specified). The DList and the GList are combined and become the new GList.

The Defect List Format specifies the format of the defect descriptor transferred to the Target when the FmtData bit is set to one (see Table 5 on page 27).

Interleave Factor must be either zero or one; the target formats the file with interleave of one.

Note: It is recommended that the Mode Select command be issued prior to the Format Unit command to specify parameters that affect the formatting process.

The Block Length parameter (see 1.6.1.2, “Block Descriptor” on page 73) is used during formatting and is saved following a successful format operation. If a Mode Select command has not been issued since the last reset or start-up (bring-up) sequence, then the Block Length from the previous format operation is used.

The RPL parameter in Mode Select page 04h, affects the way that track and cylinder skew are physically applied. See 1.6.6, “Page 4h - Rigid Disk Drive Geometry Parameters” on page 97, 1.6.5, “Page 3 - Format Device Parameters” on page 94, and 4.5, “Motor Synchronization” on page 225 for more information. The current RPL parameter is used to control the desired track and cylinder skew definitions for the format operation, regardless of the state of motor synchronization.

Subsequent to receiving a Format Unit command the Target responds to commands as follows.

- All commands except Request Sense and Inquiry return *Check Condition Status* while the format operation is an active I/O process (see 4.1.6, “Command Processing During Start-up and Format Operations” on page 205).
- When tagged queuing is enabled (DQue = 0), all commands except Request Sense and Inquiry return *Queue Full Status* while the Format Unit command is a queued I/O process (see 4.3, “Command Queuing” on page 221).
- When tagged queuing is disabled (DQue = 1), all commands except Request Sense and Inquiry return *Busy Status* while the Format Unit command is a queued I/O process.
- If a Request Sense command is received while a format operation is an active I/O process, the Target returns *Good Status*. The sense key is set to Not Ready and the additional sense code and qualifier is set to Format In Progress.
- If an Inquiry command is received while a format operation is an active I/O process, the Target returns *Good Status* and Inquiry data as requested.

The format operation must complete successfully for the Drive to be usable. If the command is interrupted by a reset, power down, or an unrecoverable error, the Drive enters a degraded mode of operation in which reading and writing are prohibited (see 4.1.9, “Degraded Mode” on page 208). To exit the degraded mode, another Format Unit command must be sent by the Initiator and completed successfully by the Target.

The Format Unit command sets the Unit Attention condition for all Initiators except the one that issued the Format Unit command (see 4.1.5, “Unit Attention Condition” on page 202).

Note: While the Format Unit command effectively erases the entire data area of the Drive, this use is not recommended. To erase data areas on the Drive and save time, use the Write Same command.

Table 3. Format of Defect List - Header								
Byte	BIT							
	7	6	5	4	3	2	1	0
0	Reserved = 0							
1	FOV	DPRY	DCRT	STPF	IP = 0	DSP = 0	Immed	RSVD
2 3	(MSB)Defect list length (LSB)							

Table 4. Format of Defect List - Descriptor(s)								
Byte	BIT							
	7	6	5	4	3	2	1	0
0 - 7	Defect Descriptor 0							
8n - 8n+7	Defect Descriptor n							
Note: Format of the defect list sent during the Data Out phase.								

The Target has a limited implementation of the Format Option bits located in Bits 2 through 7 of Byte 1 of the Defect List Header (see Table 3). If the Initiator attempts to select any function not implemented by the Target, the Target terminates the command with *Check Condition Status*. The sense key is set to Illegal Request and the additional sense code is set to Invalid Field In Parameter List.

An FOV (Format Options Valid) bit of zero causes the Target to verify that the settings for the DPRY (Disable PRimarY), DCRT (Disable CeRTification), STPF (SToP Format) IP (Initialization Pattern), and DSP (Disable Saving Parameters) bits are zero. If any of these bits are not zero, the Target terminates the command with *Check Condition Status*. The sense key is set to Illegal Request and the additional sense code is set to Invalid Field In Parameter List.

When FOV bit is one there are four combinations of the DPRY, DCRT, STPF, IP and DSP bits allowed. Any other combinations return a *Check Condition Status*. With a sense key of Illegal Request and an additional sense code of Invalid Field In Parameter List. The supported combinations are:

DPRY=0 DCRT=0 STPF=1 IP=0 DSP=0

DPRY=0 DCRT=1 STPF=1 IP=0 DSP=0

DPRY=1 DCRT=0 STPF=1 IP=0 DSP=0

DPRY=1 DCRT=1 STPF=1 IP=0 DSP=0

The DPRY (disable primary) bit set to one indicates that the Target does use portions of the medium identified as defective in the primary defect PList for Initiator addressable logical blocks.

The DPRY (disable primary) bit set to zero indicates that the Target does not use portions of the medium identified as defective in the primary defect PList for Initiator addressable logical blocks. If the Target cannot locate the PList or it cannot

determine whether a PList exists, the Target terminates the Format Unit command as described for STPF=1.

The DCRT (disable certification) bit set to one, indicates that the Target does not generate a CList (certification list) or perform a certification process while executing the Format Unit Command.

The DCRT (disable certification) bit set to zero, indicates that the Target performs a certification process while executing the Format Unit Command. (This will lengthen the time it takes to complete the Format command.)

The STPF (stop format) bit controls the behavior of the Target when one of the following events occurs:

- The Target cannot locate a required defect list nor determine that the list exists.
- The Target encounters an unrecoverable error while accessing a required defect list.

The STPF bit must be set to one. If one or both of the above conditions occurs, the Target terminates the Format Unit command with *Check Condition Status*. The sense key is set to Medium Error and the additional sense code is set to either Defect List Not Found if the first condition occurred, or Defect List Error if the second condition occurred.

The IP (initialization pattern) bit must be set to zero. The Target initializes all data with zeros.

The DSP (disable saving parameters) bit must be zero. The Target saves all the Mode Select savable parameters during the format operation.

An Immed bit set to zero requests that status be returned at the end of the format operation.

An Immed bit set to one requests that status be returned immediately. *Good Status* is returned following the CDB validation and transfer of data in the Data Out phase. If the immediate format operation terminates in error, Deferred Error Sense data is generated. See 4.1.8, “Deferred Error Condition” on page 207 for more information regarding the immediate format operation. With the Immed bit set to one, the Link bit must be set to zero.

The Defect List Length field specifies the total length in bytes of the defect descriptors that follow. The defect list length must be equal to eight times the number of defect descriptors to follow, otherwise the command is terminated with *Check Condition Status*. The sense key is set to Illegal Request and the additional sense code is set to Invalid Field In Parameter List. The defect descriptors must specify the defect based on the current Format Device parameters reported by the Mode Sense command.

The following table describes the influence of the various options on the format operation.

Table 5. Effect of Options on Format operations						
<u>FmtData</u>	<u>CmpList</u>	<u>Defect List Format</u>	<u>Defect List Length</u>	<u>Command Type</u> M = Mandatory O = Optional	<u>Defect Sources</u> P = PLlist G = GLlist D = DLlist	<u>New GLlist Composition</u> E = Erase the GLlist K = Keep the GLlist A = Add the DLlist to the GLlist R = Replace the GLlist with DLlist
<u>No Defect List</u>						
0	0	000b	N/A	M	P,G	K
<u>Block Format</u>						
1	0	000b	Zero	M	P,G	K
1	1	000b	Zero	M	P	E
<u>Bytes From Index Format</u>						
1	0	100b	Zero	O	P,G	K
1	1	100b	Zero	O	P	E
1	0	100b	> 0	O	P,G,D	A
1	1	100b	> 0	O	P,D	R
<u>Physical Sector Format</u>						
1	0	101b	Zero	O	P,G	K
1	1	101b	Zero	O	P	E
1	0	101b	> 0	O	P,G,D	A
1	1	101b	> 0	O	P,D	R

The Target supports two defect descriptor formats for the Format Unit command and the Read Defect Data commands, Bytes From Index format and Physical Sector format (see Table 5).

The Target does not require that DLlist entries be in ascending order.

If the DLlist entry does not correspond to a valid user addressable media location, the command terminates with *Check Condition Status*. The sense key is set to Illegal Request and the additional sense code is set to Invalid Field In Parameter List.

Table 6. Defect Descriptor - Bytes From Index format								
Byte	BIT							
	7	6	5	4	3	2	1	0
0	(MSB)							
1	Cylinder Number of Defect (LSB)							
2								
3	Head Number of Defect							
4	(MSB)							
5	Defect Bytes From Index (LSB)							
6								
7								

Each defect descriptor for the Bytes From Index format specifies that the sector containing this byte be marked defective. The defect descriptor is comprised of the cylinder number of the defect, the head number of the defect, and the defect bytes from index. The internal format of the Target's GList is not identical to the DList, thus the DList entry is interpreted as a defect which starts at the beginning of the sector pointed to by the DList entry, with a length equal to the sector length. If the Initiator sends more than one defect descriptor for the same sector, the Target creates one GList entry for each defect descriptor.

Note: For the specified block size, if the Dlist entry when converted to a physical sector, is equal to the physical sector of a Plist entry (DPRY = 1), that Dlist entry is not added to the Dlist.

If the Target receives a defect bytes from index value of FFFFFFFFh, indicating that the entire track be marked defective, the command is terminated with *Check Condition Status*. The sense key is set to Illegal Request and the additional sense code is set to Invalid Field In Parameter List.

Table 7. Defect Descriptor - Physical Sector Format								
Byte	BIT							
	7	6	5	4	3	2	1	0
0	(MSB)							
1	Cylinder Number of Defect (LSB)							
2								
3	Head Number of Defect							
4	(MSB)							
5	Defective Sector Number (LSB)							
6								
7								

Each defect descriptor for the Physical Sector format specifies a defect that is the length of a sector. The defect descriptor is comprised of the cylinder number of the defect, the head number of the defect, and the defect sector number. The actual defect stored in the Glist points to the start of the sector and has a length equal to the sector size. If the Initiator sends more than one defect descriptor for the same sector, the Target creates one GList entry for each defect descriptor.

Note: For the specified block size, if the Dlist entry when converted to a physical sector, is equal to the physical sector of a Plist entry (DPRY = 1), that Dlist entry is not added to the Dlist.

If the Target receives a defect sector value of FFFFFFFFh, indicating that the entire track be marked defective, the command is terminated with *Check Condition Status*. The sense key is set to Illegal Request and the additional sense code is set to Invalid Field In Parameter List.

1.3 Inquiry

Byte	BIT							
	7	6	5	4	3	2	1	0
0	Operation Code = 12h							
1	LUN			Reserved = 0				EVPD
2	Page Code							
3	Reserved = 0							
4	Allocation Length							
5	VU = 0		Reserved = 0				Flag	Link

The Inquiry command requests that information regarding parameters of the Target and its peripheral device(s) be sent to the Initiator. Several options allow the Initiator to request detailed Vital Product Data (VPD) about the Drive.

EVPD (Enable Vital Product Data) bit set to zero specifies the Target return standard Inquiry data. When the EVPD bit is set to zero, The Page Code field must also be zero. If the Page Code is not zero, the target reports Check Condition status with the sense key set to Illegal Request and the additional sense code set to Invalid Field in CDB (24 00).

EVPD (Enable Vital Product Data) bit set to one requests that the target will return the vital product data specified by the Page Code field. Page Code specifies which page of VPD information the target will return. The supported VPD pages are defined in EVPD page 00h. If the value in the Page Code Field is not a supported page the target reports Check Condition status with the sense key set to Illegal Request and the additional sense code set to Invalid Field in CDB (24 00).

Allocation Length specifies the number of bytes the Initiator allocated for returned Inquiry Data. Allocation length of zero is not an error and means that no data is returned. The target terminates the Data In phase when all requested Inquiry Data has been returned or when the number of bytes returned equals the allocation length, whichever is less.

The Inquiry command returns Check Condition status only when the target cannot return the requested Inquiry data.

If an Inquiry command is received from an Initiator with a pending Unit Attention (that is, before the target reports Check Condition status), the target performs the Inquiry command and does not clear the Unit Attention condition.

Note: The Inquiry Command is not queued. For more information see 4.3, “Command Queuing” on page 221.

Note: The inquiry data is set at the time of manufacture and will not change (without a FRU change), with the following exceptions:

- *ASCII ROM code Revision Level (EVPD=0)* can be changed when the micro-code is downloaded with the WRITE BUFFER command.
- *ASCII RAM Load Revision Level (EVPD=0)* can be changed when the micro-code is downloaded with the WRITE BUFFER command.

- *ASCII RAM uCode Load P/N (EVPD=0)* can be changed when the microcode is downloaded with the WRITE BUFFER command.
- *Load ID (EVPD= 1, Page Code= 3)* can be changed when the microcode is downloaded with the WRITE BUFFER command.
- *Release level/modification number (EVPD= 1, Page Code= 3)* can be changed when the microcode is downloaded with the WRITE BUFFER command.
- *ASCII ROM uCode Load P/N (EVPD= 1, Page Code= 3)* can be changed when the microcode is downloaded with the WRITE BUFFER command.

Note: The Inquiry data returned when media is not available will not be complete.

1.3.1 Inquiry Data Format - EVPD = 0

Table 9. Standard Inquiry Data - EVPD = 0								
Byte	BIT							
	7	6	5	4	3	2	1	0
0	Peripheral Qualifier = 0			Peripheral Device Type = 0				
1	RMB = 0	Device Type Modifier = 0						
2	ISO = 0		ECMA = 0			ANSI = 2		
3	RSVD = 0	TrmIOP = 0	Reserved = 0		Response Data Format = 2			
4	Additional Length = 159 (9Fh)							
5-6	Reserved = 0							
7	RelAdr = 0	WBus32 = 0	WBus16 = 0	SYNC = 1	Linked = 1	TranDis = 1	CmdQue = 1	SftRe = 0
8-15	ASCII Vendor ID 'IBM OEM '							
16-19	ASCII Product Type							
20-22	ASCII Model Number							
23-31	Unused							
32-33	ASCII ROM code Revision Level							
34-35	ASCII RAM Load Revision Level							
36-43	ASCII Unit Serial Number							
44-55	ASCII RAM uCode Load P/N							
56-95	Reserved = 0							
96-97	Vendor Unique Reserved = 0							
98-101	ASCII Plant of Manufacture							
102-106	ASCII Date of Manufacture							
107	Unused							
108-111	ASCII FRU Count '0002'							
112-113	ASCII FRU Field Length '22'							
114-125	ASCII Assembly P/N							
126-135	ASCII Assembly EC Level							
136-147	ASCII Card Assembly P/N							
148-157	ASCII Card Assembly EC							
158-163	Reserved = 0							

If the inquiry data contained on the media is not available, bytes 0-19 and byte 32 are valid. All other fields (including fields marked Unused) contain ASCII spaces (20h) with the exception of the Unit Serial Number which contains ASCII zeros (30h) and all Reserved fields which contain zero (00h).

The Inquiry command is different from other commands in that it responds to a invalid LUN specification by returning a Qualifier of 3h and a Peripheral Device Type of 1Fh rather than a Check Condition. This indicates “Logical Unit Not Present” and is returned by this Drive for all logical unit numbers except 0.

The target returns a Qualifier of 0h and a Peripheral Device Type of 00h when the logical unit is 0. The Peripheral Qualifier field of zero (0) indicates that the peripheral device is currently connected to this logical unit. A Peripheral Device Type field of zero (0) indicates that this device is a Direct Access Storage Device (DASD).

The RMB (removable media bit) field of 0 indicates that no removal media exists.

The Device Type Modifier field is not used and is set to 0.

The ISO field of 0 indicates that this product does not claim compliance to the International Organization for Standards (ISO) version of SCSI (ISO DIS 9316).

The ECMA field of 0 indicates that this product does not claim compliance to the European Computer Manufacturers Association (ECMA) version of SCSI (ECMA-111).

The ANSI field of 2 indicates the target supports American National Standards Institute (ANSI) SCSI version 2.

The TrmIOP field of 0 indicates the Target does not support the Terminate I/O Process Message.

A Response Data Format value of 2 indicates that the data is in the format specified in ANSI X3.133-199X (SCSI-2).

Additional Length specifies the length in bytes of the parameters that follow the additional length field. If the Allocation Length of the command descriptor block is too small to transfer all of the parameters, the Additional Length parameter is not adjusted to reflect the truncation.

The RelAdr field of 0 indicates the Target does not support the Relative Addressing Mode.

The WBus32 field of 0 indicates the Target does not support 32-bit wide data transfers.

The WBus16 field of 0 indicates the Target does not support 16-bit wide data transfers. A value of 1 indicates the Target supports 16-bit wide data transfers.

Sync set to 1 indicates the Target supports synchronous data transfer.

Linked set to 1 indicates the Target supports linked commands for this logical unit.

A transfer disable (TranDis) bit of 1 indicates that the device supports the CONTINUE I/O PROCESS and TARGET TRANSFER DISABLE messages for this logical unit.

The CmdQue field of 1 indicates that the Target supports tagged command queuing.

The SftRe field of 0 indicates the Target does not respond to the Reset condition with the soft Reset alternative.

The Vendor ID is 'IBM OEM.' Or in hex (49424D204F454D20h). The field is left aligned and the unused bytes are filled with space characters (20h). This field can be customized to meet the requirements of a user.

The Product Type is a 4-character ASCII field, either DFHS or DFMS.

The Model Number field contains an ASCII 3-character model number for the device. For model information See product Functional Specification.

The ROM Code Revision Level field indicates the level of the ROM-based microcode. This is an ASCII 2-character field. The field is left aligned and the unused bytes are filled with space characters (20h).

The RAM Code Revision Level field indicates the level of the RAM-based microcode. This is an ASCII 2-character field. The field is left aligned and the unused bytes are filled with space characters (20h).

The Unit Serial Number field contains the Drive serial number. The field is numeric, right aligned and the unused bytes are ASCII zero (30h). The most significant byte, byte 36, will always be an ASCII zero.

The RAM uCode Load P/N field contains the IBM part number of the RAM microcode loaded on the media. The field is left aligned and the unused bytes are filled with space characters (20h).

The reserved bytes 56-97 contain 00h.

The Plant of Manufacture field indicates the location of the manufacturing facility that made the Drive. A code of '0983' is for San Jose, California, '0987' is for Mainz, Germany.

The Date of Manufacture field is a 5-byte field containing the Julian date (two-digit year followed by the three-digit day of the year).

The FRU Count field indicates the number of Field Replaceable Units (FRU) identification fields in inquiry.

The FRU Field Length indicates the number of following bytes used to identify each FRU.

The Assembly P/N field is a 12-byte ASCII field that contains the part number for the entire Drive assembly. The field is left aligned and the unused bytes are filled with space characters (20h).

The Assembly EC Level field is a 10-byte ASCII field that contains the Engineering Change level of the Drive assembly. The field is left aligned and the unused bytes are filled with space characters (20h).

The Card Assembly P/N field is a 12-byte ASCII field that contains the part number of the electronics package for the Drive. The field is left aligned and the unused bytes are filled with space characters (20h).

The Card Assembly EC field is a 10-byte ASCII field that contains the Engineering Change level of the electronics package for the Drive. The field is left aligned and the unused bytes are filled with space characters (20h).

1.3.2 Inquiry Data Format **EVPD = 1 - Page Code = 00**

Table 10. Inquiry data - EVPD = 1 - Page Code = 00							
Byte	BIT						
	7	6	5	4	3	2	1
0	Peripheral Qualifier			Peripheral Device Type			
1	Page Code = 00h						
2	Reserved = 0						
3	Page Length = 5						
4	First Supported Page Code = 01h						
5	Second Supported Page Code = 02h						
6	Third Supported Page Code = 03h						
7	Fourth Supported Page Code = 80h						
8	Fifth Supported Page Code = 82h						

Bytes 0-8 are always available.

See 1.3.1, “Inquiry Data Format - EVPD = 0” on page 32 for a description of the fields in byte 0.

The Page Code field is set to the value of the Page Code field in the CDB.

The Page Length field specifies the length in bytes of the parameters that follow the Page Length field (byte 3). If the Allocation Length of the command descriptor block is too small to transfer all parameters, the Page Length field is not adjusted to reflect the truncation.

The Supported Page Code fields contain the Page Code supported by the target or logical unit. The list is in ascending order.

1.3.3 Inquiry Data Format - EVPD = 1 - Page Code = 01

Table 11. Inquiry data - EVPD = 1 - Page Code = 01							
Byte	BIT						
	7	6	5	4	3	2	1
0	Peripheral Qualifier			Peripheral Device Type			
1	Page Code = 01h						
2	Reserved = 0						
3	Page Length = 47						
4	ASCII Length = 24						
5 - 16	ASCII Assembly P/N						
17	0						
18 - 27	ASCII Assembly EC						
28	0						
29 - 40	EBCDIC Assembly P/N						
41 - 50	EBCDIC Assembly EC						

If the media is not available, bytes 0-4 are valid, the ASCII fields contain ASCII spaces (20h) and the EBCDIC fields contain EBCDIC spaces (40h), all other fields are zero (00h).

See 1.3.1, "Inquiry Data Format - EVPD = 0" on page 32 for a description of the fields in byte 0.

The Page Code field is set to the value of the Page Code field in the CDB and is associated with the Field Replaceable Unit code returned by the Request Sense Command.

The Page Length field specifies the length (in bytes) of the vendor unique VPD information (bytes 4 to 50). If the allocation length of the command descriptor block is too small to transfer all the data, the Page Length field is not adjusted to reflect the truncation.

The ASCII Length field specifies the length of the ASCII VPD information (bytes 5 through 28). If the allocation length of the command descriptor block is too small to transfer all of the ASCII VPD data, the ASCII Length field is not adjusted to reflect the truncation.

The ASCII Assembly P/N field is a twelve (12) byte ASCII field that contains the part number for the Drive assembly. The field is left aligned and the unused bytes are filled with space characters (20h).

The ASCII Assembly EC field is a ten (10) byte ASCII field that contains the Engineering Change level of the Drive assembly. The field is left aligned and the unused bytes are filled with space characters (20h).

The EBCDIC Assembly P/N field is a twelve (12) byte EBCDIC field that contains the part number for the Drive assembly. The field is left aligned and the unused bytes are filled with space characters (40h).

The EBCDIC Assembly EC field is a ten (10) byte EBCDIC field that contains the Engineering Change level of the Drive assembly. The field is left aligned and the unused bytes are filled with space characters (40h).

1.3.4 Inquiry Data Format - EVPD = 1 - Page Code = 02

Table 12. Inquiry data - EVPD = 1 - Page Code = 02							
Byte	BIT						
	7	6	5	4	3	2	1
0	Peripheral Qualifier			Peripheral Device Type			
1	Page Code = 02h						
2	Reserved = 0						
3	Page Length = 47						
4	ASCII Length = 24						
5 - 16	ASCII Card P/N						
17	0						
18 - 27	ASCII Card EC						
28	0						
29 - 40	EBCDIC Card P/N						
41 - 50	EBCDIC Card EC						

If the media is not available, bytes 0-4 are valid, the ASCII fields contain ASCII spaces (20h) and the EBCDIC fields contain EBCDIC spaces (40h), all other fields are zero (00h).

See 1.3.1, “Inquiry Data Format - EVPD = 0” on page 32 for a description of the fields in byte 0.

The Page Code field is set to the value of the Page Code field in the CDB and is associated with the Field Replaceable Unit code returned by the Request Sense Command.

The Page Length field specifies the length (in bytes) of the vendor unique VPD information (bytes 4 to 50). If the allocation length of the command descriptor block is too small to transfer all the data, the Page Length field is not adjusted to reflect the truncation.

The ASCII Length field specifies the length of the ASCII VPD information that follows (bytes 5 through 27). If the allocation length of the command descriptor block is too small to transfer all of the ASCII VPD data, the ASCII Length field is not adjusted to reflect the truncation.

The ASCII Card P/N field is a twelve (12) byte ASCII field that contains the part number for the Drive card assembly. The field is left aligned and the unused bytes are filled with space characters (20h).

The ASCII Card EC field is a 10-byte ASCII field that contains the Engineering Change level of the electronics package for the Drive. The field is left aligned and the unused bytes are filled with space characters (20h).

The EBCDIC Card P/N field is a twelve (12) byte EBCDIC field that contains the part number for the Drive card assembly.

The EBCDIC Card EC field is a 10-byte EBCDIC field that contains the Engineering Change level of the electronics package for the Drive. The field is left aligned and the unused bytes are filled with space characters (40h).

1.3.5 Inquiry Data Format - EVPD = 1 - Page Code = 03

Table 13. Inquiry data - EVPD = 1 - Page Code = 03								
Byte	BIT							
	7	6	5	4	3	2	1	0
0	Peripheral Qualifier			Peripheral Device Type				
1	Page Code = 03h							
2	Reserved = 0							
3	Page Length = 36							
4	ASCII Length = 0							
5 - 7	Reserved = 0							
8 - 11	Load ID							
12 - 15	Release level/modification number							
16 - 19	PTF Number = 0							
20 - 23	Patch Number = 0							
24 - 35	ASCII ROM uCode Load P/N							
36 - 39	ASCII Servo P/N							

If the media is not available bytes 0-11 are valid, all other fields contain zeros (00h).

See 1.3.1, “Inquiry Data Format - EVPD = 0” on page 32 for a description of the fields in byte 0.

The Page Code field is set to the value of the Page Code field in the CDB and is associated with the Field Replaceable Unit code returned by the Request Sense Command.

The Page Length field specifies the length (in bytes) of the vendor unique VPD information (bytes 4-20). If the allocation length of the command descriptor block is too small to transfer all the data, the Page Length field is not adjusted to reflect the truncation.

The Load ID is used as a mechanism to determine whether compatibility exists between ROM and RAM microcode levels.

The Release level/modification number is an indication of the generation level within the Load ID.

Both the PTF Number and the Patch Number are not used and should be reserved as zero.

Bytes 8-23 of this page are used to control the level of microcode that is installed on the Drive. See 1.34, “Write Buffer” on page 160.

Bytes 24-35 of this page display the part number of the ROM microcode which is installed on the Drive. The field is numeric (ASCII), left aligned and the unused bytes are ASCII spaces (20h).

Bytes 36-39 of this page display the part number of the Servo microcode installed on the drive. This field is hex numeric ASCII.

1.3.6 Inquiry Data Format - EVPD = 1 - Page Code = 80

Table 14. Inquiry data - EVPD = 1 - Page Code = 80							
Byte	BIT						
	7	6	5	4	3	2	1
0	Periph Qualifier			Peripheral Device Type			
1	Page Code = 80h						
2	Reserved = 0						
3	Page Length = 16						
4-19	ASCII Unit Serial Number						

If the media is not available, bytes 0-3 are valid. All other fields contain ASCII spaces (20h).

See 1.3.1, “Inquiry Data Format - EVPD = 0” on page 32 for a description of the fields in byte 0.

The Page Code field is set to the value of the Page Code field in the CDB

The Page Length field specifies the length (in bytes) of the vendor unique VPD information (bytes 4-20). If the allocation length of the command descriptor block is too small to transfer all the data, the Page Length field is not adjusted to reflect the truncation.

The Unit Serial Number field contains the Drive serial number. The field is numeric (ASCII), right aligned and the unused bytes are ASCII spaces (20h).

1.3.7 Inquiry Data Format - EVPD = 1 - Page Code = 82

Table 15. Inquiry data - EVPD = 1 - Page Code = 82								
Byte	BIT							
	7	6	5	4	3	2	1	0
0	Peripheral Qualifier			Peripheral Device Type				
1	Page Code = 82h							
2	Reserved = 0							
3	Page Length = 48							
4	ASCII Length = 25							
5 - 8	ASCII Product Type							
9	0							
10 - 12	ASCII Model Number							
13	0							
14 - 21	ASCII Serial Number							
22	0							
23 - 28	ASCII Vendor ID 'IBM'							
29	0							
30 - 33	EBCDIC Product Type							
34 - 36	EBCDIC Model Number							
37	Reserved = 0							
38 - 45	EBCDIC Serial Number							
46 - 51	EBCDIC Vendor ID 'IBM'							

If the media is not available, bytes 0-4 are valid, the ASCII fields contain ASCII spaces (20h) and the EBCDIC fields contain EBCDIC spaces (40h), all other fields are zero (00h).

See 1.3.1, “Inquiry Data Format - EVPD = 0” on page 32 for a description of the fields in byte 0.

The Page Code field is set to the value of the Page Code field in the CDB.

The Page Length field specifies the length (in bytes) of the vendor unique VPD information (bytes 4 to 51). If the allocation length of the command descriptor block is too small to transfer all the data, the Page Length field is not adjusted to reflect the truncation.

The ASCII Length field specifies the length of the ASCII VPD information that follows (bytes 5 through 29). If the allocation length of the command descriptor block is too small to transfer all of the ASCII VPD data, the ASCII VPD length field is not adjusted to reflect the truncation.

The ASCII Product Type is the four (4) character ASCII field.

The ASCII Model Number field contains a three (3) character ASCII model number for the device. See 1.3.1, “Inquiry Data Format - EVPD = 0” on page 32 for the model numbers.

The ASCII Serial Number field contains the unit serial number. The field is right aligned and the unused bytes are filled with ASCII zeros (30h).

The ASCII Vendor ID field contains the vendor ID (IBM). The field is left aligned and the unused bytes are filled with ASCII space characters (20h). This field can be customized to meet the requirements of a user.

The EBCDIC Product Type is the four (4) character EBCDIC field.

The EBCDIC Model Number field contains a three (3) character EBCDIC model number for the device. See 1.3.1, "Inquiry Data Format - EVPD = 0" on page 32 for the model numbers.

The EBCDIC Serial Number field contains the unit serial number. The field is right aligned and the unused bytes are filled with EBCDIC zeroes (F0h).

The EBCDIC Vendor ID field contains the vendor ID (IBM). The field is left aligned and the unused bytes are filled with EBCDIC space characters (40h). This field can be customized to meet the requirements of a user.

1.4 Log Select

Table 16. Log Select Command Descriptor Block								
Byte	BIT							
	7	6	5	4	3	2	1	0
0	Operation Code = 4Ch							
1	Logical Unit Number			Reserved = 0			PCR	SP
2	PC = 11b or 01b		Reserved = 0					
3	Reserved = 0							
4	Reserved = 0							
5	Reserved = 0							
6	Reserved = 0							
7	(MSB) Parameter List Length (LSB)							
8								
9	VU = 0		Reserved = 0			Flag	Link	

The *Log Select* command provides a means for the initiator to clear statistical information maintained by the Drive and reported via the Log Sense Command.

PCR bit The Parameter Code Reset (PCR) bit determines whether the Log Sense parameters will be cleared and unit attentions posted for all other initiators. A value of 1 indicates that the parameters should be cleared, while a value of 0 (except when PC=11b) indicates that the parameters should not be cleared. Parameter list length must be zero when PCR is 1.

SP bit The Save Parameters (SP) bit value of zero indicates that the page parameters not be saved. A value of 1 indicates that the page parameters that are savable be saved after they have been changed.

PC field The Page Control (PC) field defines the type of parameters to be selected. This field must be set to one of the following:

01b Current cumulative values.

11b Default cumulative values.

The PC field set to 11b (and PCR is a don't care) indicates that the Current Cumulative values are set to their default values of 0. If the PC field is set to 01b, and PCR is set to 1, the Current Cumulative values are also set to their default values.

Parameter List Length The Parameter List Length indicates the amount of data to be transferred from the initiator to the target during the DATA OUT phase. A value of zero is acceptable and is not considered an error.

Note: A specified length greater than 0x00FF will result in a check condition status being returned. A length that

results in log data being truncated will generate a check condition status.

If one or more fields in the CDB is not correctly set, the command shall be terminated with a Check Condition Status. The Sense Key shall be set to Illegal Request, and the additional sense code set to Invalid Field in CDB.

The following list contains all individual page parameters that are set to their default value of zero by the Log Select command (when PCR=1 and Parameter List Length=0).

- Page 01h parameters:
 - Overrun Counter
 - Underrun Counter
- Page 02h parameters:
 - Write Error Counter
 - Write Total Posted Recoverable Error Counter
 - Write Total Posted Unrecoverable Error Counter
 - Write Total Hidden Servo Error Counter
 - Write Total Hidden Write Fault Error Counter
- Page 03h parameters:
 - ECC OTF counter
 - Read Error Counter
 - Read Total Posted Recoverable Error Counter
 - Read Total Posted Unrecoverable Error Counter
 - Read Total Hidden Servo Errors
 - Read Total Hidden Media Errors
- Page 05h parameters:
 - Verify Error Counter
 - Verify Total Posted Recoverable Error Counter
 - Verify Total Posted Unrecoverable Error Counter
- Page 06h parameters:
 - Non-Medium Error Counter
- Page 30h parameters:
 - Zero Seeks counter.
 - Seeks $> =$ to $2/3$ counter.
 - Seeks $> = 1/3$ and $< 2/3$ counter.
 - Seeks $> = 1/6$ and $< 1/3$ counter.
 - Seeks $> = 1/12$ and $< 1/6$ counter.
 - Seeks > 0 and $< 1/12$ counter.
 - Overrun Counter.
 - Underrun Counter.
 - Device Cache Read Hits
 - Device Cache Partial Read Hits
 - Device Cache Write Hits

- Device Cache Fast Writes
- Page 35h parameters:
 - Cumulative Cache Hits on Reads.
 - Cumulative Cache Partial Hits on Reads.
 - Cumulative Cache misses on Reads.

The target generates a unit attention condition (to indicate that parameters have changed) for all initiators except the one that issued the Log Select command.

The following tables show data format for the DATA OUT phase when the Parameter list length is not equal to zero. Only log pages 1, 2, 3, 5, and 6 are acceptable pages for log select data.

1.4.1 Log Select Page 01h

Table 17. Log Select Page 01h									
Byte	BIT								
	7	6	5	4	3	2	1	0	
0	Reserved = 0		Page Code = 01h						
1	Reserved = 0								
2 - 3	Page Length								

Table 18. Log Select Page 01h Parameter Code 0000h									
Byte	BIT								
	7	6	5	4	3	2	1	0	
0 - 1	Parameter Code = 0000h								
2	DU	DS = 1	TSD = 0	ETC = 0	TMC = 0		LBIN = 0	LP = 0	
3	Parameter Length = 02h								
4 - 5	Ignored								

Table 19. Log Select Page 01h Parameter Code 0001h									
Byte	BIT								
	7	6	5	4	3	2	1	0	
0 - 1	Parameter Code = 0001h								
2	DU	DS = 1	TSD = 0	ETC = 0	TMC = 0		LBIN = 0	LP = 0	
3	Parameter Length = 02h								
4 - 5	Ignored								

1.4.2 Log Select Page 02h

Table 20. Log Select Page 02h									
Byte	BIT								
	7	6	5	4	3	2	1	0	
0	Reserved = 0		Page Code = 02h						
1	Reserved = 0								
2 - 3	Page Length								

Table 21. Log Select Page 02h - Parameter Code 0002h								
Byte	BIT							
	7	6	5	4	3	2	1	0
0 - 1	Parameter Code = 0002h							
2	DU	DS = 0	TSD = 0	ETC = 0	TMC = 0	LBIN = 0	LP = 0	
3	Parameter Length = 04h							
4 - 7	Ignored							

Table 22. Log Select Page 02h - Parameter Code 0003h								
Byte	BIT							
	7	6	5	4	3	2	1	0
0 - 1	Parameter Code = 0003h							
2	DU	DS = 0	TSD = 0	ETC = 0	TMC = 0	LBIN = 0	LP = 0	
3	Parameter Length = 04h							
4 - 7	Ignored							

Table 23. Log Select Page 02h - Parameter Code 0006h								
Byte	BIT							
	7	6	5	4	3	2	1	0
0 - 1	Parameter Code = 0006h							
2	DU	DS = 0	TSD = 0	ETC = 0	TMC = 0	LBIN = 0	LP = 0	
3	Parameter Length = 04h							
4 - 7	Ignored							

Table 24. Log Select Page 02h - Parameter Code 8000h								
Byte	BIT							
	7	6	5	4	3	2	1	0
0 - 1	Parameter Code = 8000h							
2	DU	DS = 0	TSD = 0	ETC = 0	TMC = 0	LBIN = 0	LP = 0	
3	Parameter Length = 04h							
4 - 7	Ignored							

Table 25. Log Select Page 02h - Parameter Code 8001h								
Byte	BIT							
	7	6	5	4	3	2	1	0
0 - 1	Parameter Code = 8001h							
2	DU	DS = 0	TSD = 0	ETC = 0	TMC = 0		LBIN = 0	LP = 0
3	Parameter Length = 04h							
4 - 7	Ignored							

1.4.3 Log Select Page 03h

Table 26. Log Select Page 03h								
Byte	BIT							
	7	6	5	4	3	2	1	0
0	Reserved = 0		Page Code = 03h					
1	Reserved = 0							
2 - 3	Page Length							

Table 27. Log Select Page 03h - Parameter Code 0000h								
Byte	BIT							
	7	6	5	4	3	2	1	0
0 - 1	Parameter Code = 0000h							
2	DU	DS = 1	TSD = 1	ETC = 0	TMC = 0		LBIN = 0	LP = 0
3	Parameter Length = 04h							
4 - 7	Ignored							

Table 28. Log Select Page 03h - Parameter Code 0002h								
Byte	BIT							
	7	6	5	4	3	2	1	0
0 - 1	Parameter Code = 0002h							
2	DU	DS = 0	TSD = 0	ETC = 0	TMC = 0		LBIN = 0	LP = 0
3	Parameter Length = 04h							
4 - 7	Ignored							

Table 29. Log Select Page 03h - Parameter Code 0003h								
Byte	BIT							
	7	6	5	4	3	2	1	0
0 - 1	Parameter Code = 0003h							
2	DU	DS = 0	TSD = 0	ETC = 0	TMC = 0		LBIN = 0	LP = 0
3	Parameter Length = 04h							
4 - 7	Ignored							

Table 30. Log Select Page 03h - Parameter Code 0006h								
Byte	BIT							
	7	6	5	4	3	2	1	0
0 - 1	Parameter Code = 0006h							
2	DU	DS = 0	TSD = 0	ETC = 0	TMC = 0		LBIN = 0	LP = 0
3	Parameter Length = 04h							
4 - 7	Ignored							

Table 31. Log Select Page 03h - Parameter Code 8000h								
Byte	BIT							
	7	6	5	4	3	2	1	0
0 - 1	Parameter Code = 8000h							
2	DU	DS = 0	TSD = 0	ETC = 0	TMC = 0		LBIN = 0	LP = 0
3	Parameter Length = 04h							
4 - 7	Ignored							

Table 32. Log Select Page 03h - Parameter Code 8002h								
Byte	BIT							
	7	6	5	4	3	2	1	0
0 - 1	Parameter Code = 8002h							
2	DU	DS = 0	TSD = 0	ETC = 0	TMC = 0		LBIN = 0	LP = 0
3	Parameter Length = 04h							
4 - 7	Ignored							

1.4.4 Log Select Page 05h

Table 33. Log Select Page 05h								
Byte	BIT							
	7	6	5	4	3	2	1	0
0	Reserved = 0		Page Code = 05h					
1	Reserved = 0							
2 - 3	Page Length							

Table 34. Log Sense Page 05h - Parameter Code 0000h								
Byte	BIT							
	7	6	5	4	3	2	1	0
0 - 1	Parameter Code = 0000h							
2	DU	DS = 0	TSD = 0	ETC = 0	TMC = 0		LBIN = 0	LP = 0
3	Parameter Length = 04h							
4 - 7	Ignored							

Table 35. Log Select Page 05h - Parameter Code 0002h								
Byte	BIT							
	7	6	5	4	3	2	1	0
0 - 1	Parameter Code = 0002h							
2	DU	DS = 0	TSD = 0	ETC = 0	TMC = 0		LBIN = 0	LP = 0
3	Parameter Length = 04h							
4 - 7	Ignored							

Table 36. Log Select Page 05h - Parameter Code 0003h								
Byte	BIT							
	7	6	5	4	3	2	1	0
0 - 1	Parameter Code = 0003h							
2	DU	DS = 0	TSD = 0	ETC = 0	TMC = 0		LBIN = 0	LP = 0
3	Parameter Length = 04h							
4 - 7	Ignored							

Table 37. Log Select Page 05h - Parameter Code 0006h								
Byte	BIT							
	7	6	5	4	3	2	1	0
0 - 1	Parameter Code = 0006h							
2	DU	DS = 0	TSD = 0	ETC = 0	TMC = 0		LBIN = 0	LP = 0
3	Parameter Length = 04h							
4 - 7	Ignored							

1.4.5 Log Select Page 06h

Table 38. Log Select Page 06h								
Byte	BIT							
	7	6	5	4	3	2	1	0
0	Reserved = 0		Page Code = 06h					
1	Reserved = 0							
2 - 3	Page Length							
4 - 5	Parameter Code = 0000h							
6	DU	DS = 0	TSD = 0	ETC = 0	TMC = 0		LBIN = 0	LP = 0
7	Parameter Length = 04h							
8 - 11	Ignored							

1.5 Log Sense

Table 39. Log Sense Command Descriptor Block								
Byte	BIT							
	7	6	5	4	3	2	1	0
0	Operation Code = 4Dh							
1	Logical Unit Number			RSVD = 0			PPC = 0	SP
2	PC = 11b or 01b		Page Code					
3	Reserved = 0							
4	Reserved = 0							
5	(MSB) Parameter Pointer (LSB)							
6								
7	(MSB) Allocation Length (LSB)							
8								
9	VU = 0		Reserved = 0			Flag	Link	

The *Log Sense* command allows the Initiator to retrieve statistical data about the Drive.

PPC bit

The Parameter Pointer Control (PPC) bit must be set to zero. This specifies that the Drive start transferring data starting from the field specified in the parameter pointer field for the number of bytes specified by the allocation length. If PPC bit is set to 1, Check Condition Status is returned with a Sense Key of Illegal Request and additional sense code of Invalid Field in CDB.

SP bit

The Save Parameters (SP) bit set to 0 specifies that the Drive not save any log parameters. If set to 1, all page parameters that are savable (those pages denoted by a DS = 0 in the parameter header control byte) are saved.

Note: Vendor Unique pages 30h and 35h are exceptions to this. They contain parameters that have DS = 0, but are not savable.

PC field

The Page Control field defines the type of parameters to be selected. This field must be set to 01b to specify Current Cumulative values or 11b to specify Default Cumulative values. If the PC field is set to either 00b or 10b, Check Condition Status is returned with a Sense Key of Illegal Request and additional sense code of Invalid Field in CDB.

Page Code

The Page Code field identifies which page is being requested. This field must be set to the values indicated in Page 00h. If the Page Code value is invalid, a Check Condition Status is returned with a Sense Key of Illegal Request and additional sense code of Invalid Field in CDB.

Parameter Pointer Field The parameter pointer field specifies the beginning field for the transfer. A value of 0x0000 indicates all parameters for the select page code will be returned.

Allocation Length The Allocation Length field specifies the maximum number of bytes the Initiator has allocated for returned Log Sense Data. No bytes are transferred if the allocation length is zero. This condition is not considered an error. The Target terminates the Data In phase when all available Log Sense Data has been transferred or when the number of bytes transferred equals the allocation length, whichever is less.

1.5.1 Log Page Parameters

Each log page begins with a four-byte page header followed by zero or more variable-length log parameter.

Page Header

The Page Code field identifies which log page is being transferred.

The Page Length field specifies the length in bytes of the following log parameters.

Log Parameters

Each log parameter begins with a four-byte parameter header followed by one or more bytes of parameter value data.

The Parameter Code field identifies which log parameter is being transferred for that log page.

The Parameter Control field, or 3rd byte of each parameter header, contains several fields.

- The Disable Update (DU) bit set to 0 (1) indicates that the drive updates (disable updates) the log parameter value to reflect all events that should be noted by that parameter. Although a setting of 1 is allowed, this value is ignored by the drive.
- The Disable Save (DS) bit is set to 1 for all non-savable parameters and is set to 0 for all savable parameters.

Note: Vendor Unique pages 30h and 35h are exceptions to this. They contain parameters that have DS = 0, but are not savable.

- The Target Save Disable (TSD) bit is set to 0 which indicates that the drive provides a target-defined method for saving log parameters.
- The Enable Threshold Comparison (ETC) bit is set to 0 which indicates that the drive does not perform comparisons between cumulative and any threshold values.
- The List Binary (LBIN) bit is set to 1 for the Vendor Unique pages whose parameters are lists which indicates that the lists are in binary format, not ASCII. This bit is Reserved and set to 0 for all other pages.
- The List Parameter (LP) bit is set to 0 for parameters that are data counters. The LP bit is set to 1 for parameters that are lists.

1.5.2 Log Sense Page 00h

Table 40. Log Sense Page 00h								
Byte	BIT							
	7	6	5	4	3	2	1	0
0	Reserved = 0		Page Code = 0					
1	Reserved = 0							
2 - 3	Page Length = 000Ah (Number of Pages Supported)							
4	First supported page code = 00h							
5	Second supported page code = 01h							
6	Third supported page code = 02h							
7	Fourth supported page code = 03h							
8	Fifth supported page code = 05h							
9	Sixth supported page code = 06h							
10	Seventh supported page code = 30h							
11	Eighth supported page code = 32h							
12	Ninth supported page code = 33h							
13	Tenth supported page code = 35h							

Page 00h indicates the supported log sense pages. This page is used to determine which additional pages can be requested by the Initiator.

Requesting this page with Page Code=00h and PC field = 11b will result in a Check Condition Status returned with a Sense Key of Illegal Request and additional sense of Invalid Field in CDB.

1.5.3 Log Sense Page 01h

Table 41. Log Sense Page 01h									
Byte	BIT								
	7	6	5	4	3	2	1	0	
0	Reserved = 0		Page Code = 01h						
1	Reserved = 0								
2 - 3	Page Length (<= 000Ch)								

Table 42. Log Sense Page 01h Parameter Code 0000h								
Byte	BIT							
	7	6	5	4	3	2	1	0
0 - 1	Parameter Code = 0000h							
2	DU	DS = 1	TSD = 0	ETC = 0	TMC = 0	RSVD = 0	LP = 0	
3	Parameter Length = 02h							
4 - 5	Buffer Under-Run Counter							

Table 43. Log Sense Page 01h Parameter Code 0001h								
Byte	BIT							
	7	6	5	4	3	2	1	0
0 - 1	Parameter Code = 0001h							
2	DU	DS = 1	TSD = 0	ETC = 0	TMC = 0	RSVD = 0	LP = 0	
3	Parameter Length = 02h							
4 - 5	Buffer Over-Run Counter							

A buffer overrun or underrun condition occurs when the Initiator does not transfer data to or from the Target data buffer fast enough to keep up with reading or writing the media. The buffer overrun counter is incremented during operations that require a Data In phase when a buffer full condition prevents the continued transfer of data from the media to the data buffer. The buffer underrun counter is incremented during operations that require a Data Out phase when a buffer empty condition prevents the start or continuation of a data transfer from the data buffer to the media (or a data transfer from the media for a Verify command with BytChk=1).

Buffer Overrun conditions are detected during the following SCSI commands or pair of linked commands:

- Read (6)
- Read (10)

Buffer Underrun conditions are detected during the following SCSI commands or pair of linked commands:

- Verify with BytChk=1
- Write (6)
- Write (10)
- Write and Verify

- Write Same

The statistics reported by this page are lost when the Drive is powered off or a self-initiated reset occurs.

The statistics reported by this page are NOT lost on a SCSI reset or Bus Device Reset message.

1.5.4 Log Sense Page 02h

Table 44. Log Sense Page 02h									
Byte	BIT								
	7	6	5	4	3	2	1	0	
0	Reserved = 0		Page Code = 02h						
1	Reserved = 0								
2 - 3	Page Length < = 0028h								

Table 45. Log Sense Page 02h - Parameter Code 0002h								
Byte	BIT							
	7	6	5	4	3	2	1	0
0 - 1	Parameter Code = 0002h							
2	DU	DS = 0	TSD = 0	ETC = 0	TMC = 0		RSVD = 0	LP = 0
3	Parameter Length = 04h							
4 - 7	Write Error Counter							

Table 46. Log Sense Page 02h - Parameter Code 0003h								
Byte	BIT							
	7	6	5	4	3	2	1	0
0 - 1	Parameter Code = 0003h							
2	DU	DS = 0	TSD = 0	ETC = 0	TMC = 0		RSVD = 0	LP = 0
3	Parameter Length = 04h							
4 - 7	Write Total Posted Recoverable Errors							

Table 47. Log Sense Page 02h - Parameter Code 0006h								
Byte	BIT							
	7	6	5	4	3	2	1	0
0 - 1	Parameter Code = 0006h							
2	DU	DS = 0	TSD = 0	ETC = 0	TMC = 0		RSVD = 0	LP = 0
3	Parameter Length = 04h							
4 - 7	Write Total Posted Unrecoverable Errors							

Table 48. Log Sense Page 02h - Parameter Code 8000h								
Byte	BIT							
	7	6	5	4	3	2	1	0
0 - 1	Parameter Code = 8000h							
2	DU	DS = 0	TSD = 0	ETC = 0	TMC = 0		RSVD = 0	LP = 0
3	Parameter Length = 04h							
4 - 7	Write Total Hidden Servo Errors							

Table 49. Log Sense Page 02h - Parameter Code 8001h								
Byte	BIT							
	7	6	5	4	3	2	1	0
0 - 1	Parameter Code = 8001h							
2	DU	DS = 0	TSD = 0	ETC = 0	TMC = 0		RSVD = 0	LP = 0
3	Parameter Length = 04h							
4 - 7	Write Total Hidden Fault Errors							

This parameter counter is incremented during failed write operations.

The statistics reported by this page are not lost when the Drive is powered off or a self-initiated reset occurs, on a SCSI reset or Bus Device Reset message.

1.5.5 Log Sense Page 03h

Table 50. Log Sense Page 03h								
Byte	BIT							
	7	6	5	4	3	2	1	0
0	Reserved = 0		Page Code = 03h					
1	Reserved = 0							
2 - 3	Page Length < = 0030h							

Table 51. Log Sense Page 03h - Parameter Code 0000h								
Byte	BIT							
	7	6	5	4	3	2	1	0
0 - 1	Parameter Code = 0000h							
2	DU	DS = 1	TSD = 1	ETC = 0	TMC = 0		RSVD = 0	LP = 0
3	Parameter Length = 04h							
4 - 7	ECC OTF Counter							

Table 52. Log Sense Page 03h - Parameter Code 0002h								
Byte	BIT							
	7	6	5	4	3	2	1	0
0 - 1	Parameter Code = 0002h							
2	DU	DS = 0	TSD = 0	ETC = 0	TMC = 0		RSVD = 0	LP = 0
3	Parameter Length = 04h							
4 - 7	Read Error Counter							

Table 53. Log Sense Page 03h - Parameter Code 0003h								
Byte	BIT							
	7	6	5	4	3	2	1	0
0 - 1	Parameter Code = 0003h							
2	DU	DS = 0	TSD = 0	ETC = 0	TMC = 0		RSVD = 0	LP = 0
3	Parameter Length = 04h							
4 - 7	Read Total Posted Recoverable Errors							

Table 54. Log Sense Page 03h - Parameter Code 0006h								
Byte	BIT							
	7	6	5	4	3	2	1	0
0 - 1	Parameter Code = 0006h							
2	DU	DS = 0	TSD = 0	ETC = 0	TMC = 0		RSVD = 0	LP = 0
3	Parameter Length = 04h							
4 - 7	Read Total Posted Unrecoverable Errors							

Table 55. Log Sense Page 03h - Parameter Code 8000h								
Byte	BIT							
	7	6	5	4	3	2	1	0
0 - 1	Parameter Code = 8000h							
2	DU	DS = 0	TSD = 0	ETC = 0	TMC = 0		RSVD = 0	LP = 0
3	Parameter Length = 04h							
4 - 7	Read Total Hidden Servo Errors							

Table 56. Log Sense Page 03h - Parameter Code 8002h								
Byte	BIT							
	7	6	5	4	3	2	1	0
0 - 1	Parameter Code = 8002h							
2	DU	DS = 0	TSD = 0	ETC = 0	TMC = 0		RSVD = 0	LP = 0
3	Parameter Length = 04h							
4 - 7	Read Total Hidden Media Errors							

The Read Error Counter is incremented during failed read operations.

The ECC OTF Counter is incremented each time ECC on-the-fly hardware correction is used. The maximum value that it will reach before wrapping to zero is 0x0000FFFF. The counter resets to zero when the Drive is powered on.

The statistics reported by this page are not lost (except ECC OTF which is lost) when the Drive is powered off or a self-initiated reset occurs, on a SCSI reset or Bus Device Reset message.

1.5.6 Log Sense Page 05h

Table 57. Log Sense Page 05h								
Byte	BIT							
	7	6	5	4	3	2	1	0
0	Reserved = 0		Page Code = 05h					
1	Reserved = 0							
2 - 3	Page Length <= 0020h							

Table 58. Log Sense Page 05h - Parameter Code 0000h								
Byte	BIT							
	7	6	5	4	3	2	1	0
0 - 1	Parameter Code = 0000h							
2	DU	DS = 0	TSD = 0	ETC = 0	TMC = 0		RSVD = 0	LP = 0
3	Parameter Length = 04h							
4 - 7	Verify With No Delay Error Counter							

Table 59. Log Sense Page 05h - Parameter Code 0002h								
Byte	BIT							
	7	6	5	4	3	2	1	0
0 - 1	Parameter Code = 0002h							
2	DU	DS = 0	TSD = 0	ETC = 0	TMC = 0		RSVD = 0	LP = 0
3	Parameter Length = 04h							
4 - 7	Verify Error Counter							

Table 60. Log Sense Page 05h - Parameter Code 0003h								
Byte	BIT							
	7	6	5	4	3	2	1	0
0 - 1	Parameter Code = 0003h							
2	DU	DS = 0	TSD = 0	ETC = 0	TMC = 0		RSVD = 0	LP = 0
3	Parameter Length = 04h							
4 - 7	Verify Total Posted Recoverable Errors							

Table 61. Log Sense Page 05h - Parameter Code 0006h								
Byte	BIT							
	7	6	5	4	3	2	1	0
0 - 1	Parameter Code = 0006h							
2	DU	DS = 0	TSD = 0	ETC = 0	TMC = 0		RSVD = 0	LP = 0
3	Parameter Length = 04h							
4 - 7	Verify Total Posted Unrecoverable Errors							

This parameter counter is incremented during failed verify operations.

The statistics reported by this page are not lost when the Drive is powered off or a self-initiated reset occurs, on a SCSI reset or Bus Device Reset message.

1.5.7 Log Sense Page 06h

Table 62. Log Sense Page 06h								
Byte	BIT							
	7	6	5	4	3	2	1	0
0	Reserved = 0		Page Code = 06h					
1	Reserved = 0							
2 - 3	Page Length = 0008h							
4 - 5	Parameter Code = 0000h							
6	DU	DS = 0	TSD = 0	ETC = 0	TMC = 0		RSVD = 0	LP = 0
7	Parameter Length = 04h							
8 - 11	Non-Medium Error Counter							

This parameter counter is incremented every time a non-medium error is detected.

The statistics reported by this page are not lost when the Drive is powered off or a self-initiated reset occurs, on a SCSI reset or Bus Device Reset message.

1.5.8 Log Sense Page 30h

Table 63. Log Sense Page 30h									
Byte	BIT								
	7	6	5	4	3	2	1	0	
0	Reserved = 0		Page Code = 30h						
1	Reserved = 0								
2 - 3	Page Length = 0030h								
4 - 5	Parameter Code = 0								
6	DU	DS = 0	TSD = 0	ETC = 0	TMC = 0		LBIN = 0	LP = 0	
7	Parameter Length = 2Ch								
8 - 9	Zero Seeks								
10 - 11	Seeks > = to 2/3 disk								
12 - 13	Seeks > = 1/3 and < 2/3								
14 - 15	Seeks > = 1/6 and < 1/3								
16 - 17	Seeks > = 1/12 and < 1/6								
18 - 19	Seeks > 0 and < 1/12								
20 - 23	Reserved = 0								
24 - 25	Overrun Counter								
26 - 27	Underrun Counter								
28 - 31	Device Cache Read Hits								
32 - 35	Device Cache Partial Read Hits								
36 - 39	Device Cache Write Hits = 0								
40 - 43	Device Cache Fast Writes = 0								
44 - 51	Reserved = 0								

Page 30h returns performance counter information. This includes seek counters and buffer overrun/underrun counters.

The appropriate seek counter is incremented once during the execution of each of the following SCSI commands or pair of linked commands:

- Pre-Fetch
- Read (6)
- Read (10)
- Verify
- Write (6)
- Write (10)
- Write and Verify
- Write Same
- Seek (6)
- Seek (10)

Only one seek counter is incremented for each of these commands and the counter is incremented only once per command. The length of the initial seek that is required to access the first Logical Block specified for the SCSI command determines which seek counter is incremented. The Zero Seek counter is incremented if a seek is not required or if only a head switch is required to access the first Logical

Block. After the initial seek, no further counter incrementing is performed for that command.

Implementer's Note - The length of a seek as reported in page 30 may differ from expected results. The reason for this is that the drive executes Idle Time Functions (as explained in the product Functional Specification) between operations of the drive. The seek operations which occur in Idle Time Functions are not directly entered into page 30 seek counters but they change the length of the following seek. This is because after the Idle Time Function is completed, the heads will not necessarily be in the same position as they were at the completion of the previous command.

A buffer overrun or underrun condition occurs when the Initiator does not transfer data to or from the Target data buffer fast enough to keep up with reading or writing the media. The buffer overrun counter is incremented during operations that require a Data In phase when a buffer full condition prevents the continued transfer of data from the media to the data buffer. The buffer underrun counter is incremented during operations that require a Data Out phase when a buffer empty condition prevents the start or continuation of a data transfer from the data buffer to the media (or a data transfer from the media for a Verify command with `BytChk=1`).

Buffer Overrun conditions are detected during the following SCSI commands:

- Read (6)
- Read (10)

Buffer Underrun conditions are detected during the following SCSI commands:

- Verify with `BytChk=1`
- Write (6)
- Write (10)
- Write and Verify
- Write Same

ZERO SEEKS The number of times no seek was required. The operation may have resulted in a head switch.

SEEKS > = 2/3 DISK The number of seeks equal to or greater than 2/3 of the disk.

SEEKS > = 1/3 AND < 2/3 DISK The number of seeks equal to or greater than 1/3 and less than 2/3 of the disk.

SEEKS > = 1/6 AND < 1/3 DISK The number of seeks equal to or greater than 1/6 and less than 1/3 of the disk.

SEEKS > = 1/12 AND < 1/6 DISK The number of seeks equal to or greater than 1/12 and less than 1/6 of the disk.

SEEKS > 0 AND < 1/12 DISK The number of seeks less than 1/12 of the disk.

OVERRUN COUNTER The number of times that data was available to be transferred from the arm but the device buffer still contained data that had not been retrieved by the Initiator. Consequently, the disk had to take additional revolutions until the buffer was available to accept data.

UNDERRUN COUNTER The number of times that the DASD was ready to transfer data to its disk (on a write), but its buffer was empty (ie. had not been filled by the Initiator) thus the disk was forced to take extra revolutions.

DEVICE CACHE READ HITS The number of times that all of the data requested by the read operation was obtained from the device read or write cache. This is a duplicate of the Cumulative Cache Hits on Reads counter on page 35.

DEVICE CACHE PARTIAL READ HITS The number of times that a portion, but not all, of the data requested by the read operation was obtained from the device read or write cache. A physical operation to the device media was required to obtain the remaining data. This is a duplicate of the Cumulative Cache Partial Hits on Reads counter on page 35.

DEVICE CACHE WRITE HITS The number of times that the data associated with a write operation replaces, or is combined with, existing data in the device write cache, thereby eliminating a write operation. This counter will always be zero.

DEVICE CACHE FAST WRITES The number of times that space was available in the device write cache for the data associated with a write operation and a response was returned immediately. This counter will always be zero.

The statistics reported by this page are lost on a self-initiated reset or when the Drive is powered off.

The statistics reported by this page are NOT lost on a SCSI reset or Bus Device Reset message.

Even though the DS field equals zero, the parameters on this page are not saveable.

1.5.9 Log Sense Page 32h

Table 64. Log Sense Page 32h							
Byte	BIT						
	7	6	5	4	3	2	1
0	Reserved = 0			Page Code = 32h			
1	Reserved = 0						
2	(MSB)						
3	Page Length = $ln_0 + \dots + ln_n$ (LSB)						
Log Parameter(s)							
4 $ln_0 +$ 3	Log Parameter 0 (Length ln_0)						
-----	-----						
$x - ln_n$ x	Log Parameter n (Length ln_n)						

1.5.9.1 Log Parameter Format - Page 32h

Table 65. Log Parameter Format - Page 32h								
Byte	BIT							
	7	6	5	4	3	2	1	0
0	(MSB)							
1	Parameter Code = 0, 1, ..., n-1, or n (LSB)							
2	DU	DS = 0	TSD = 0	ETC = 0	TMC = 0		LBIN = 1	LP = 1
3	Parameter Length = 8(m+1)							
4	(MSB)							
5	Cylinder Number of Site 0							
6	(LSB)							
7	Head Number of Site 0							
8	(MSB)							
9	Sector Number of Site 0							
10								
11	(LSB)							
-----	-----							
8m + 4	(MSB)							
8m + 5	Cylinder Number of Site m							
8m + 6	(LSB)							
8m + 7	Head Number of Site m							
8m + 8	(MSB)							
8m + 9	Sector Number of Site m							
8m + 10								
8m + 11	(LSB)							

Page 32h is a listing of physical error sites that should be reallocated. (See 4.7, “Automatic Rewrite/Reallocate - Recommend Rewrite/Reassign” on page 228 for more information.) When an error site is reallocated, it is removed from this list. When a format is performed, this list is cleared. If no sites require reallocation, 8 bytes are returned, the page length is 4 and the parameter length is 0.

The statistics reported to the Initiator by this page are part of error log information maintained by the Target. The logs are periodically saved to the disk and are restored from the disk after a power cycle or self-initiated reset.

Implementer's Note - The Initiator may request this page and return the 8 byte site descriptions to the Target as a Dlist when issuing a Format command with Dlist option.

Even though the DS field equals zero, the parameters on this page are not saveable.

Requesting this page with Page Code=00h and PC field = 11b will result in a Check Condition Status returned with a Sense Key of Illegal Request and additional sense of Invalid Field in CDB.

1.5.10 Log Sense Page 33h

Table 66. Log Sense Page 33h									
Byte	BIT								
	7	6	5	4	3	2	1	0	
0	Reserved = 0		Page Code = 33h						
1	Reserved = 0								
2	(MSB)								
3	Page Length = $ln_0 + \dots + ln_n$								(LSB)
Log Parameter(s)									
4	Log Parameter 0								
$ln_0 +$	(Length ln_0)								
3	-----								
$x - ln_n$	Log Parameter n								
x	(Length ln_n)								

1.5.10.1 Log Parameter Format - Page 33h

Table 67. Log Parameter Format - Page 33h									
Byte	BIT								
	7	6	5	4	3	2	1	0	
0	(MSB)								
1	Parameter Code = 0, 1, ..., n-1, or n								(LSB)
2	DU	DS = 0	TSD = 0	ETC = 0	TMC = 0		LBIN = 1	LP = 1	
3	Parameter Length = $4(m+1)$								
4	(MSB)								
5	Logical Block Address 0								
6									
7									(LSB)
-----	-----								
$4m + 4$	(MSB)								
$4m + 5$	Logical Block Address m								
$4m + 6$									
$4m + 7$									(LSB)

Page 33h is a listing of LBAs that should be reallocated. (See 4.7, “Automatic Rewrite/Reallocate - Recommend Rewrite/Reassign” on page 228 for more information.) The data returned by the Target is sorted in descending LBA order. When an error site is reallocated, it is removed from this list. When a format is performed, this list is cleared. If no sites require reallocation, 8 bytes are returned, the page length is 4 and the parameter length is 0.

The statistics reported by this page are part of error log information maintained by the Target. The logs are periodically saved to the disk and are restored from the disk after a power cycle or self-initiated reset.

Implementer's Note - The Initiator may request this page when ready to reassign LBAs that the Target has recommended for reallocation. The Initiator should issue a reassign command for each LBA in the order received. This assures that the reas-

signs occur in the correct descending order. (Otherwise, incorrect LBAs may be reassigned.)

Even though the DS field equals zero, the parameters on this page are not saveable.

Requesting this page with Page Code=00h and PC field = 11b will result in a Check Condition Status returned with a Sense Key of Illegal Request and additional sense of Invalid Field in CDB.

1.5.11 Log Sense Page 35h

Table 68. Log Sense Page 35h									
Byte	BIT								
	7	6	5	4	3	2	1	0	
0	Reserved = 0		Page Code = 35h						
1	Reserved = 0								
2 - 3	Page Length = 0028h (40)								
4 - 5	Parameter Code = 0								
6	DU	DS = 0	TSD = 0	ETC = 0	TMC = 0		LBIN = 0	LP = 0	
7	Parameter Length = 24h (36)								
8 - 11	Cumulative Cache Hits on Reads.								
12 - 15	Cumulative Cache Partial Hits on Reads.								
16 - 19	Cumulative Cache misses on Reads.								
20 - 43	Reserved = 0								

Page 35h contains information about cache utilization.

The Cache Hit parameter is incremented when all of the Requested Data is in the cache. The Cache Miss parameter is incremented when the start of the Requested Data is not in the cache. The Cache Partial Hit parameter is incremented when the start of the Requested Data is in the cache and the end is not.

Implementer's Note - The Initiator may use this information to "fine tune" the caching parameters for the particular application it is using. (See 4.9, "Segmented Caching" on page 231 for more information.)

The statistics reported by this page are lost when the Drive is powered off or a self-initiated reset occurs.

The statistics reported by this page are NOT lost on a SCSI reset or Bus Device Reset message.

Even though the DS field equals zero, the parameters on this page are not saveable.

1.6 Mode Select (6)

Byte	BIT							
	7	6	5	4	3	2	1	0
0	Operation Code = 15h							
1	LUN			PF	Reserved = 0			SP
2	Reserved = 0							
3	Reserved = 0							
4	Parameter List Length							
5	VU = 0			Reserved = 0			Flag	Link

The Mode Select command provides a means for the Initiator to specify LUN or device parameters to the Target. It also allows an Initiator to specify options the Target uses in error recovery and formatting.

There is a single set of Mode Page parameters shared by all initiators.

A PF (Page Format) bit value of 1 indicates the data sent by the Initiator after the Mode Select Header and the Block Descriptor, if any, complies to the Page Format. The Target ignores this field since it only accepts mode parameters in the Page Format.

The SP (Save Parameter) bit set to 0 indicates that the Target does not save the saveable pages sent during the Data Out phase to disk. The SP bit value of 1, indicates that the Target saves the saveable pages to the Reserved Area. Saveable Pages are Pages for which a preceding Mode Sense command returned the PS bit of the Page Header set to 1 (see 1.7, “Mode Sense (6)” on page 109).

The Parameter List Length field specifies the number of bytes of data the Initiator has available to send to the LUN. A parameter list length of zero suppresses data transfer and is not considered an error.

The Mode Select parameter list contains a 4-byte header, followed by zero or one Block Descriptor followed by zero or more pages, as shown in Table 70 on page 72.

The Initiator should issue a Mode Sense command requesting all changeable values (see PC field in byte two of the CDB for 1.7, “Mode Sense (6)” on page 109) prior to issuing a Mode Select command. This is necessary to find out which pages are implemented by the Target and the length of those pages. The Target returns in the pages of the Mode Sense command the number of bytes supported for each page. The Page Length set by the Initiator in the Mode Select command must be the same value as that returned by the Target in Mode Sense page length. If this is not true, the Target sets *Check Condition Status* with the sense key of Illegal Request and additional sense code of Parameter List Length Error.

If any of the parameters sent by a Mode Select command are invalid, *Check Condition Status* is returned with a Sense Key of Illegal Request and Additional Sense Code of Invalid Field in Parameter List. The SKSV bit is on and the invalid byte is indicated in the Field Pointer field. The BPV bit is on and the invalid bit is indi-

cated in the Bit Pointer field (see Appendix A, “SCSI Sense Data Format” on page 247).

Each time the Initiator receives a Unit Attention (see 4.1.5, “Unit Attention Condition” on page 202) sense key from the Target, the Initiator must assume the Target's mode of operation has been changed. The Initiator may need to reconfigure the Target to its requirements. See 1.7, “Mode Sense (6)” on page 109 to determine the Target's parameters.

A Mode Select command also causes a Unit Attention condition (see 4.1.5, “Unit Attention Condition” on page 202) for all initiators except the one that issued the Mode Select command.

Mode page parameter Current values are equal to the Default values before the Saved values are read from the Reserved Area of the media. The non-zero Mode page parameter Default values are always:

PAGE 00h

- *ASDPE* bit is set to 1.

PAGE 01h

- *Read Retry Count* field is set to 01h.
- *Correction Span* field is set to 30h (Decimal 48).
- *Write Retry Count* field is set to 01h.

PAGE 03h

- *Data Bytes per Physical Sector* is set to the current formatted block size.
- *Tracks per Zone* is based on the Device Model Number.
- The *Interleave* field is set to 0001h (Decimal 1),
- The *HSEC* bit is set to 1.
- The exact Default values of the following parameters are Model Number dependant and are defined in the *product Functional Specification*. Use the current logical Block Length along with the default "Active Notch = 0000h" when calculating them.
 - *Sectors per Track*
 - *Track Skew Factor*
 - *Cylinder Skew Factor*

PAGE 04h

- *Number of Cylinders* is based on the Device Model Number. Refer to the product Functional Specification for the number of cylinders.
- *Number of Heads* is based on the Device Model Number. Refer to the product Functional Specification for the number of heads.
- *Landing Zone* is based on the Device Model Number. The Landing Zone can be calculated by adding 200 to the maximum cylinder for the device. Refer to the product Functional Specification for the maximum cylinder value.
- *Medium Rotation Rate* is based on the Device Model Number. Refer to the product Functional Specification for the rotation rate.

PAGE 07h

- *Verify Retry Count* is set to 01h.

PAGE 08h

- *Disable Pre-fetch Transfer Length* is set to FFFFh,
- *Maximum Pre-fetch* is set to FFFFh,
- *Maximum Pre-fetch Ceiling* is set to FFFFh.
- *Number of Cache Segments* field is set to 8.

Not all of the Mode Select options on all pages are both changeable and saveable (also see 1.7, “Mode Sense (6)” on page 109).

All Saved values that are changeable, are stored on the disk and can be initialized with a Mode Select command of the Saved parameters. This allows customers to individualize the value of the Current parameters after a start-up sequence without having to issue a Mode Select command to change the Current parameters every time the Drive is spun up.

Byte	BIT							
	7	6	5	4	3	2	1	0
0	Reserved = 0							
1	Medium Type = 0							
2	WP	Reserved = 0		DPOFUA	Reserved = 0			
3	Block Descriptor Length = 0 or 8							

1.6.1.1 Header

The only portion of the Mode Select Header that the Initiator can specify is the Block Descriptor Length field. A maximum of one block Descriptor may be specified. Therefore, the Block Descriptor Length field may only have values of 0 or 8.

A Medium Type value of 00h indicates that the Drive is using its only recording density.

The WP (Write Protect) bit of zero indicates the target is write enabled. A WP bit of one indicates the target is write protected. The Target enters Write Protect mode via a pin on the Option Block: Write Protect can not be entered via the Mode Select command. Refer to 4.15, “Options Jumper Block” on page 241 for information regarding the Options Jumper Block.

When in Write Protect mode, the following commands cause the Target to set *Check Condition Status* with sense indicating Write Protected:

- Format Unit
- Synchronize Cache
- Write
- Write Extended
- Write and Verify
- Write Same
- Write Long
- Reassign Blocks

In addition, automatic rewrites and reallocates are prohibited. Recommend Rewrite/Reallocate is not affected by the Write Protect mode.

The DPOFUA bit, is considered reserved on the Mode Select Command by SCSI-2. The Target ignores the value in the DPOFUA field on a Mode Select command.

Table 71. Mode Select Parameter List - Block Descriptor								
Byte	BIT							
	7	6	5	4	3	2	1	0
0	Reserved = 0							
1	(MSB) Number of Blocks (LSB)							
2								
3								
4	Reserved = 0							
5	(MSB) Block Length (LSB)							
6								
7								

1.6.1.2 Block Descriptor

The Block Descriptor specifies the Number of Blocks (user addressable) to format at the specified Block Length. It can be used to specify the default number of blocks or can specify a smaller number for Initiators who wish to limit the number of blocks on the Drive. The default Number of Blocks is the most blocks which can fit on the Drive at the specified Block Length.

The Initiator specifies the Number of Blocks in one of three ways:

- A value of 000000h indicates that the number of blocks will not change from the current value if the block descriptor block length remains the same as the current block length, If the block descriptor block length is different than the current block length, the default maximum number of blocks is used.
- A value of FFFFFFFh indicates that the default maximum number of blocks will be used.
- A value other than 0 or FFFFFFFh specifies the number of blocks. This value must be less than or equal to the default number of blocks. If an illegal value is specified for the Number of Blocks field, the command fails with *Check Condition Status* with sense key of Illegal Request and additional Sense Code of Invalid Field in Parameter List. For higher capacity models whose default number of blocks is greater than 0xFFFFFE, there is no provision to set the number of blocks to values between 0xFFFFFE and the default number of blocks.

A Format Unit command is required to cause these parameters to become current only if the block length parameter is different than the current block length. If the Number of Blocks is set to a reduced value and a Format Unit command is issued, the Format Unit will format the entire Drive but the number of blocks visible to the Initiator will be limited to the specified number.

The Block Length is specified in bytes.

Note: Refer to the product Functional Specification for information regarding supported block lengths for this product.

There is an implicit association between parameters defined in the Format Device Page (03h) and the Block Descriptor. If the values in the Block Descriptor are different than the Current values, then the Current and Saved values of some or all of the Format Device page parameters may change. See 1.6.5, “Page 3 - Format Device Parameters” on page 94 for details on those values.

Table 72. Mode Select Parameter List - Page Descriptor(s)									
Byte	BIT								
	7	6	5	4	3	2	1	0	
0	RSVD = 0	RSVD = 0	Page Code						
1 2-n	Page Length (in bytes) Refer to each page								

1.6.1.3 Page Descriptor

Byte zero contains the code of the desired page. Bits 7 and 6 of Byte zero are reserved and must be set to 0. The Page Length field must be set equal to the supported length of the entire page minus 2 bytes. The remaining bytes contain the page parameters.

If an Initiator sends multiple copies of a page to the Target, the last one received is used. This is not considered an error.

1.6.2 Page 0 - Vendor Unique Parameters

Table 73. Mode Select Data Format Page 0									
Byte	BIT								
	7	6	5	4	3	2	1	0	
0	RSVD = 0	RSVD = 0	Page Code = 00h						
1	Page Length = 0Eh								
2	QPE	ignored	DWD	Reserved = 0					
3	ASDPE	DPW	CMDAC	RPF AE	DOTF	ignored	RRNDE	CPE	
4	Ignored								
5	Ignored	TCC	DSN	FRDD	DPSDP	Ignored	CAEN	LITF	
6	ignored								
7	ignored								
8	ignored	ADC	QEMC	DRD	LED Mode				
9	ignored								
10	Command Aging Time Limit (HI)								
11	Command Aging Time Limit (LO)								
12	QPE read threshold								
13	QPE-2 write threshold								
14	DRRT	DNR	DUASS	RARRED	ignored				
15	RTP	RRC	FCERT	RCPF	ignored				

Following are parameter options for Page 0 of Mode Select. Refer to Table 73.

Byte 2 contains the following fields -

QPE The QPE (Qualify Posted Errors) bit allows the Initiator to inhibit the reporting of recovered data errors which are recovered below a set DRP step. A QPE bit of 0 causes the Target to report all recovered data errors. A QPE bit of 1 causes the Target to report only those recovered data errors which exceed the QPE threshold. All error reporting is governed by Mode Page 1 parameters. For example, QPE is ignored when PER is 0.

The bit applies to data errors while reading (No Sector Found, ID and Data Sync Errors, ID CRC Errors and ECC Errors) and data errors while writing (No Sector Found, ID Sync and ID CRC errors). The QPE bit has no effect on non-data errors or errors detected during verify operations.

Note: See 1.6.7, “Page 7h - Error Recovery Parameters for Verify” on page 100 for information on control of reporting verify errors via the Verify PER bit.

The user can accept the default reporting thresholds (DRP step 25 for reads, step 1 for writes), or can specify the thresholds by using bytes 12 and 13 of this page. (DRP levels are described in the Appendix section B.1, “Data Recovery Procedure for Data Field Errors” on page 273.)

The QPE bit setting is used by the Target when reporting errors associated with the transfer of the Initiator's data for the following commands:

- Read(6)
- Read(10)
- Write(6)
- Write(10)
- Write Same
- Write portion of Write and Verify

For all other commands the QPE bit setting is unused and treated as 0.

DWD The DWD (disable write disconnect) bit allows the Initiator to control whether the Target is allowed to disconnect following the receipt of a Write (6), Write (10), Write and Verify or Write Same command (opcodes 0Ah, 2Ah, 2Eh and 41h). A DWD bit of 0 allows the Target to disconnect from the SCSI Bus after receiving a Write command and prior to starting the Data Out phase. (The previous Identify message must also grant the Target the privilege of disconnection or the Target does not disconnect.) A DWD bit of 1 indicates that the Target is not allowed to disconnect from the SCSI bus after receiving a Write command and prior to starting the Data Out phase unless the write command must be queued. The Target remains connected to the SCSI bus until the Data Out phase is started. After the Data Out phase is started, the Target may disconnect to free the SCSI bus for use by other devices. This occurs if the Target's internal control algorithms and other disconnect/reconnect control parameters indicate that this is appropriate and permissible.

Byte 3 contains the following fields -

ASDPE The ASDPE (Additional Save Data Pointer Enable) bit determines whether or not the Save Data Pointer message is sent to the Initiator prior to disconnection. This bit is only used by the Target after the Default Mode parameter values are overridden with the Saved values which are read from the Reserved Area of the media as a part of the motor start-up sequence. Before the Saved values are read from the Reserved Area of the media, the Save Data Pointer message is always sent to the Initiator prior to disconnection.

When ASDPE is set to 1, the Save Data Pointer message is sent prior to every disconnect. When ASDPE is set to 0, the Save Data Pointer message is only sent prior to disconnection if the following conditions are true:

- A Data phase has occurred since the connection for the current command was established, and
- Another Data phase is required to successfully complete the command.

Note: A Save Data Pointer message is not sent prior to the Disconnect message of the TTD data ready sequence regardless of the ASDPE bit. See 3.1.16, "Target Transfer Disable (13h)" on page 172 for more information.

DPW The DPW (Disable Physical Writes) bit determines if Physical Writes will be done in the last step of Error Recovery. If DPW=0 then Physical Writes are enabled for the last step of Write Error Recovery. If DPW=1 then Physical Writes are disabled for the last step of Write Error Recovery.

CMDAC The CMDAC bit controls how the Target defines a signal on the LED pin that indicates when the Drive is "active". See the *product Functional Specification* for details on the electrical parameters of this LED Pin signal.

The signal is provided on the LED pin only when the LED pin is initially detected to be at a TTL high level (HIGH) when the Drive is powered on. If the LED Pin is detected to be HIGH at that time, then

- When the CMDAC bit = 1
 - The LED pin goes to a TTL low level (LOW) for a "Command Active" condition when -
 1. A CDB (other than Request Sense or Inquiry) is received by the Target.
 2. An "Active LUN" condition is in effect.
 - The LED pin goes HIGH for a "Command Inactive" condition when a -
 1. LUN becomes inactive following the successful completion of a host initiated command or termination due to an error or exception condition
 2. LUN becomes inactive following the completion of Active LUN condition or termination due to an error or exception condition
 3. SCSI Bus Reset or a SCSI Bus Reset Message is received
 4. Self-Initiated reset is performed
 5. previously received command is terminated via an Abort message

Note: In the case of Immediate commands such as Format and Start Unit, the LED pin does not become HIGH until the corresponding Active Lun condition for this command has been completed.

Note: The LED pin does not become LOW during idle activity such as Disk Sweep.

- When the CMDAC bit = 0
 - The LED pin goes LOW for a "Motor Active" condition which means that the Spindle Motor is spinning.
 - The LED pin goes HIGH for a "Motor Inactive" condition which means that the Spindle Motor is not spinning.

RPFAE The RPFAE (Report Predictive Failure Analysis Error) bit allows certain recovered errors to be reported at the completion of the command that handled the data when PER=0. (PER=0 normally inhibits the reporting of all recovered errors. See 1.6.3, "Page 1 - Error Recovery Parameters" on page 83 for more details on reporting recovered errors.)

An RPFAE bit of 1 indicates that recovered errors that are associated with the drive's Predictive Failure Analysis (PFA) functions are reported. When RPFAE is set to 0, whether or not recovered errors are reported is based upon the state of the PER bit. The PFA functions include the Auto/Recommend Rewrite/Reassign (ARRE) functions. See 4.7, "Automatic Rewrite/Reallocate - Recommend Rewrite/Reassign" on page 228

The reporting of recovered errors are controlled by the setting of the PER, QPE, RPF AE, and RARRED bits as follows:

Table 74.				
PER	QPE	RPF AE	RARRED	Reporting of Recovered Errors
0	x	0	x	Recovered errors are not reported.
0	x	1	0	Only recovered errors associated with the PFA functions are reported.
0	x	1	1	Only recovered errors associated with the PFA functions are reported except that recovered errors associated with the Automatic/Recommend Rewrite/Reallocate (ARRE) function are not reported.
1	0	x	x	All recovered errors are reported.
1	1	x	x	Recovered errors that are above the threshold defined by the QPE bit are reported, plus recovered errors that are associated with the PFA functions.
Note: See 4.8, “Predictive Failure Analysis” on page 230 for details concerning PFA.				

DOTF The DOTF (Disable ECC On The Fly) bit determines if ECC On The Fly will be enabled. If DOTF is not set then ECC On The Fly correction is enabled. If DOTF is set then ECC On The Fly correction is disabled and Software ECC correction will be used in place of ECC On the Fly correction.

RRNDE The RRNDE (Report Recovered Non Data Errors) bit controls the reporting of recovered Non Data Errors when the PER bit is set. If RRNDE is set then recovered Non Data Errors are reported. If the RRNDE bit is not set then recovered Non Data Errors are not reported.

CPE The CPE (concurrent processing enable) bit controls whether or not I/O process are allowed to execute concurrently. Concurrent processing is when multiple I/O processes are active (not queued). This implies the Data phase of I/O processes are allowed to overlap. The Target utilizes concurrent processing to perform back to back writes. (See 4.4.1, “Back to Back Writes” on page 225.)

When concurrent processing is disabled, only one non-priority I/O process will be active at a time. Priority commands are never queued and are always allowed to execute concurrently. (See 4.2, “Priority Commands” on page 220.)

Concurrent Processing is enabled if CPE = 1.

Concurrent Processing is disabled if CPE = 0.

Byte 4 is Ignored which is treated the same as a Reserved field except that it is allowed to be set to any value.

Byte 5 contains the following fields:

TCC The Track Compensation Control bit causes certain Idle Time Functions (such as Servo Run Out, Bias Measurements, Predictive Failure Analysis and error log updates) to execute during Rezero Unit commands. A TCC bit of 1 causes the Rezero Unit Command to execute Idle Time Functions while a TCC bit of 0 indicates that the Rezero Unit Command will NOT force Idle Time Functions.

When Idle Time Functions are executed internal timers are reset, thus allowing a time span during which the Drive response time will not be degraded by these activities. This may be useful when the Initiator wants to insure predictable response time.

Note: This bit cannot be used to delay periodic internal events past their regularly scheduled intervals.

DSN The Disable Target Initiated Synchronous Negotiation bit indicates whether the Drive will perform Target Initiated Synchronous Negotiation and Target Initiated Transfer Width Negotiation. A bit of 1 indicates the Drive does not perform Target Initiated Synchronous and Transfer Width Negotiation, while a bit of 0 indicates that the Drive does.

Note: The DSN bit is an indicator bit only. Changing this bit does not have any functional effect on the Drive. The actual function is controlled by an Option Jumper as described in the *product Functional Specification*.

FRDD A FRDD (Format and Reassign Degraded Disable) bit of 1 prevents the Drive from reporting Format or Reassign degraded on a Test Unit Ready Command, and causes media access commands (ie. read, write) to report a media error if degraded. A FRDD bit of 0 indicates that Format or Reassign degraded is reported on Test Unit Ready commands.

DPSDP The Data Phase Save Data Pointer bit controls whether the Drive sends a Save Data Pointer message at the end of the data phase. A DPSDP bit of 0 indicates that the Drive sends a Save Data Pointer message prior to disconnection only if the following conditions are true:

A data phase has occurred since the connection for the current command was established.

Another data phase is required to successfully complete the command.

A DPSDP bit of 1 indicates that the Drive will send a Save Data Pointer message prior to every disconnection once a data phase has occurred for the current command. If the ASDPE bit is set to 1, the Save Data Pointer message is sent prior to every disconnect regardless of the value of the DPSDP bit.

Note: A Save Data Pointer message is not sent prior to the Disconnect message of the TTD data ready sequence regardless of the ASDPE and DPSDP bits. See 3.1.16, “Target Transfer Disable (13h)” on page 172 for more information.

CAEN The Command Aging Enable bit used in conjunction with the Command Aging Time Limit bytes, allows the Initiator to limit the amount of time a command can be queued. The CAEN bit set to 1, causes the target to reorder a command to the earliest possible execution time after the command has been in the queue for the time duration specified in the Command Aging Time Limit bytes. Restrictions on the reordering algorithm as specified by the Queue Algorithm Modifier (see 1.6.9, “Page 0Ah - Control Mode Parameters” on page 105) still apply in this case. Data

integrity is maintained when Restricted Reordering is in effect. A CAEN bit equal to 0 indicates that Command Aging is not enabled and the Command Aging Time Limit bytes are ignored.

LITF The Limit Idle Time Functions bit controls whether Predictive Failure Analysis (PFA) is performed during Idle Time. For an explanation of "Idle Time Functions" refer to the product Functional Specification. A bit of 1 indicates PFA functions will not be performed during Idle periods. This may help prevent delays as mentioned in the product Functional Specification. A bit of 0 indicates that the Drive will perform PFA during Idle Time.

Byte 6 and Byte 7 are ignored.

Byte 8 contains the ADC, QEMC bit, DRD bit, and the LED Pin Indicator Modes for the LED.

ADC The ADC (Adaptive Caching) affects the Target's caching algorithm. If the ADC bit is set to one, the Target will set the Number of Cache Segments equal to 8, and may alter this number to optimize performance. When the initiator clears ADC after having ADC set, the drive will default the number of cache segments to 8. This can be modified by changing the Number of Cache Segments in Page 8, Byte 13 to the number desired. With ADC set, the Target may also alter the prefetch based on perceived random or sequential operations. If the ADC bit is zero the Target will use the cache as defined by Page 8h, Caching parameters.

QEMC The QEMC (Queue Error Management Control) affects the Target's operation when QErr is set to a one. QEMC has no effect if QErr = 0. See QErr on 1.6.9, "Page 0Ah - Control Mode Parameters" on page 105 for a description on the how QEMC effects QErr.

DRD The DRD (disable read disconnect) bit when set to 1 prevents the target from disconnecting from the SCSI Bus following the receipt of a Read (6) or a Read (10) command until it has determined that the requested data is not available in the data buffer. If the data is available, the target will not disconnect prior to starting the data transfer unless the read command must be queued. If the data is not available, the target will disconnect until enough data has been read from the disk to satisfy the reconnection criteria as determined by the Read Buffer Full Ratio. A DRD bit of 0 allows the target to disconnect immediately after the receipt of a read command without determining if the requested data is available.

LED Mode = 0h (Compatibility) The CMDAC bit controls the LED mode.

CMDAC = 1 (Command Active)

CMDAC = 0 (Motor Active)

LED Mode = 1h (Motor Active). When the motor is spinning, the LED is high.

LED Mode = 2h (Command Active). When there is a command active or in the queue, the LED is high.

LED Mode = 3h (Degraded). When the Target is in any degraded mode, the LED is high.

LED Mode = 4h (Command Active | Degraded). When there is a command active/queued OR when the Target is in any degraded mode, the LED is high.

LED Mode = 5h-Fh (Reserved for future use).

Byte 9 is reserved and must be zero.

Byte 10 and Byte 11 are used as a timer for the Drive's Command Aging Feature when enabled by the CAEN bit in byte 5. The Command Aging Time Limit Timer is in 50 ms increments.

Byte 12 specifies the error reporting threshold for read operations when the QPE bit is set. A value of 0 or 0ffh indicates that the Drive default value shall be used. Any other value is interpreted as the threshold. A recovered error which requires more steps of recovery than the threshold will be reported.

Byte 13 specifies the error reporting threshold for write operations when the QPE bit is set. A value of 0 or 0ffh indicates that the Drive default value shall be used. Any other value is interpreted as the threshold. A recovered error which requires more steps of recovery than the threshold will be reported.

Byte 14 contains the DRRT, DNR, DUASS and RARRED bits.

DRRT The DRRT (Disable Read Reassign Target) bit Disables the reading and restoration of the target LBA during a reassign. If the DRRT bit is zero, the reassign command attempts to restore the target LBA's data. If the data cannot be restored, the sector is reassigned and written with a data pattern of all FF's. If the DRRT bit is one, no attempt is made to restore the target LBA.

DNR The DNR (Disable Nested Reassign) bit disables nested reassigns. If the DNR bit is zero, nested reassigns are performed. If the DNR bit is one, Nested reassigns are not done and only the target LBA is re-assigned.

DUASS The DUASS (Disable Unit Attention on Spindle Synchronization) controls the reporting of the Unit Attention(UA) condition associated with Spindle Synchronization. If the DUASS bit is set then no UA will be generated due to changes in Spindle Synchronization. If the DUASS bit is not set then a UA will be generated due to changes in Spindle Synchronization.

RARRED The RARRED (Report Automatic/Recommend Rewrite/Reallocate Disabled) bit controls reporting Sense Data for recovered errors associated with this function when the PER and RPF AE bits are set. If the RARRED bit is set then recovered errors associated with the ARRE function are not reported. If the RARRED bit is not set then recovered errors associated with the ARRE function are reported.

Byte 15 is reserved and must be zero.

RTP The RTP (Reassign Target Padd) bit determines whether the reassign target sector is padded with 00h or FFh. If the RTP bit is set to 0 then the target sector is padded with 00h. If the RTP bit is set to 1 then the target sector is padded with FFh.

RRC	The RRC (Read Retry Count) bit determines how the retry count on page 1 byte 3 is used. If the page 0 RRC bit is 0 and page 1 read retry count is 0 then No recovery is performed. If the page 0 RRC bit is 0 and page 1 read retry count is 1 then Maximum recovery is performed. If the page 0 RRC bit is 1 then the page 1 read retry count is the maximum level of recovery performed.
FCERT	When the Format Unit command is issued with NO data out phase, the FCERT (Format Certification) bit determines whether the certification step will be performed during the Format command. An FCERT bit set to 0 disables certification. An FCERT bit set to 1 enables the certification step. When Format Unit is issued with a data out phase the FCERT bit is over ridden by the DCRT bit in the Format Defect List Header.
RCPF	The RCPF (Report Component PFAGEM Failures) bit determines whether component PFAGEM failures will be reported. An RCPF bit set to 0 disables reporting of component PFAGEM failures. An RCPF bit set to 1 enables the reporting of component PFAGEM failures.

1.6.3 Page 1 - Error Recovery Parameters

Table 75. Mode Select Data Format Page 1									
Byte	BIT								
	7	6	5	4	3	2	1	0	
0	RSVD = 0	RSVD = 0	Page Code = 01h						
1	Page Length = 0Ah								
2	AWRE	ARRE	TB	RC	EER = 0	PER	DTE	DCR	
3	Read Retry Count								
4	Correction Span = 30h (or 0)								
5	Head Offset Count = 0								
6	Data Strobe Offset Count = 0								
7	Reserved = 0								
8	Write Retry Count								
9	Reserved = 0								
10 11	(MSB)	Recovery Time Limit = 0						(LSB)	

Since bytes 4-11 are not changeable, the Mode Select Command accepts only the values indicated in Table 75 for bytes 4 - 11, with the exception of Correction Span which is noted below.

Following are parameter options for Page 1 of Mode Select. Refer to Table 75.

Byte 2 contains the following fields -

AWRE (Automatic Write Reallocation Enable) bit of 1 enables automatic reallocation to be performed during write operations. The automatic reallocation is performed only if the Target has the valid data (e.g., original data in the buffer or recovered from the medium). The valid data is placed in the reallocated block. All error recovery actions required by the error recovery bits (TB, EER, PER, DTE and DCR) are executed. Error reporting as required by the error recovery bits (EER, PER, DTE, and DCR) is performed only after completion of the reallocation. Therefore any failures that occur during the reallocation are reported. See 4.7, “Automatic Rewrite/Reallocate - Recommend Rewrite/Reassign” on page 228 for execution details and error procedures.

Note: Only write errors detected while reading an ID can cause an Automatic Write Reallocation to occur.

When AWRE bit = 0, the Target does not perform automatic reallocation of defective data blocks during write operations. The AWRE bit setting is used by the Target when an error occurs during the transfer of the Initiator's data for the following commands:

- Write(6)
- Write(10)
- Write Same
- Write portion of Write and Verify

For all other commands, the AWRE bit setting is unused and treated as 0.

ARRE (Automatic Read Reallocation Enable) = 1, enables automatic reallocation of defective blocks found during read operations. The automatic reallocation is performed only if the Target successfully recovers the data. All error recovery actions required by the error recovery bits (TB, EER, PER, DTE and DCR) are executed. Error reporting as required by the error recovery bits (EER, PER, DTE, and DCR) is performed only after completion of the reallocation. Therefore any failures that occur during the reallocation are reported. See 4.7, “Automatic Rewrite/Reallocate - Recommend Rewrite/Reassign” on page 228 for execution details and error procedures.

When ARRE = 0, the Target does not perform automatic reallocation of defective blocks found during read operations. The ARRE bit setting is used by the Target when an error occurs during the transfer of the Initiator's data for the following commands:

- Read(6)
- Read(10)

For all other commands, the ARRE bit setting is unused and treated as 0.

TB (Transfer Block) Bit set to 1 indicates that the failing block be transferred to the Initiator.

TB set to 0 requests that a failing block not be transferred to the Initiator.

If an unrecoverable error occurs and TB is set to a value of 1, the Target transfers the failing block of uncorrected data if the unrecoverable error is a data error (that is, there is data available to transfer). An Initiator may make this distinction by issuing a Request Sense command and examining the Additional Sense code. An Additional Sense code of 11h indicates an unrecoverable read error in the data block. The failing block is transferred only for this case. The TB bit setting is used by the Target when reporting errors associated with the transfer of the Initiator's data for the following commands:

- Read(6)
- Read(10)

For all other commands, the TB bit setting is unused and treated as 0.

RC (Read Continuous) bit set to 1 requests the Target to transfer the entire requested length of data without adding delays which would increase or ensure data integrity. This implies that the Target may send erroneous data. This bit has priority over all other error control bits (PER, DTE, DCR, TB).

Note: The Target implementation of the RC option is to disable error detection of the data fields but continue normal error detection and recovery for errors occurring in the ID field. If an ID cannot be found, then normal DRP could result in considerable recovery action, including proceeding through all levels of DRP.

RC set to 0 indicates normal interpretation of PER, DTE, DCR, and TB values. The RC bit setting is used by the Target when reporting errors associated with the transfer of the Initiator's data for the following commands:

- Read(6)
- Read(10)
- Prefetch

For all other commands, the RC bit setting is unused and treated as 0.

EER (Enable Early Recovery) The EER bit must be 0. The Target does not support early recovery.

PER (Post Error) Bit set to 1 requests that the Target report *Check Condition Status* for all recovered data and non-data errors, with the appropriate Sense key. The *Check Condition Status* occurs during data transfer depending either on the DTE setting or occurrence of an unrecoverable error. If multiple errors occur, the Request Sense data reports the block address of either the last block on which the recovered error occurred or of the first unrecoverable error.

PER set to 0 requests that the Target not create *Check Condition Status* for recovered errors. The PER bit setting is used by the Target when reporting errors associated with the transfer of the Initiator's data for the following commands:

- Read(6)
- Read(10)
- Write(6)
- Write(10)
- Write Same
- Write and Verify - the write portion of the command only.

Note: (See the description of the RPF AE bit in the section describing 1.6.2, “Page 0 - Vendor Unique Parameters” on page 75 for information regarding the reporting of soft errors associated with Predictive Failure Analysis functions.)

For all other commands, the PER bit setting is unused and treated as 0.

DTE (Disable Transfer on Error) Bit set to 1 indicates that the Target creates the *Check Condition Status* and terminates the data transfer to the Initiator upon transferring the last byte of the recovered block when a data error is recovered. The Transfer Length may not be exhausted. DTE may only be set to 1 if PER is also set to 1. The Target creates *Check Condition Status* with Illegal Request sense key if this is not so. DTE set to 1 inhibits Automatic/Recommend Rewrite/Reallocate.

DTE set to 0 continues data transfer through recovered errors. The DTE bit setting is used by the Target when reporting errors associated with the transfer of the Initiator's data for the following commands:

- Read(6)
- Read(10)
- Write(6)
- Write(10)
- Write Same
- Write and Verify - the write portion of the command only.

For all other commands, the DTE bit setting is unused and treated as 0.

DCR (Disable Correction) set to 1 indicates that ECC (error correction codes) are not applied in the course of error recovery. DTE set to 1 inhibits Automatic/Recommend Rewrite/Reallocate.

DCR set to 0 enables error correction. The DCR bit setting is used by the Target when reporting errors associated with the transfer of the Initiator's data for the following commands:

- Read(6)
- Read(10)

For all other commands, the DCR bit setting is unused and treated as 0.

The following summarizes valid modes of operation.

PER	DTE	DCR	TB	Description	
0	0	0	0	Retries and error correction are attempted. Recovered and/or corrected data (if any) is transferred with no <i>Check Condition Status</i> at the end of the transfer.	
				soft error	The transfer length is exhausted. Transferred data includes blocks containing recovered errors.
				hard error	Data transfer stops when the unrecoverable error is encountered. The unrecoverable block is not transferred to the Initiator.
0	0	0	1	Retries and error correction are attempted. Recovered and/or corrected data (if any) is transferred with no <i>Check Condition Status</i> at the end of the transfer.	
				soft error	The transfer length is exhausted. Transferred data includes blocks containing recovered errors.
				hard error	Data transfer stops when the unrecoverable error is encountered. The unrecoverable block is transferred to the Initiator (if data error).
0	0	1	0	Retries are attempted but no error correction (ECC) is applied. Recovered data (if any) is transferred with no <i>Check Condition Status</i> at the end of the transfer.	
				soft error	The transfer length is exhausted. Transferred data includes blocks containing recovered errors.
				hard error	Data transfer stops when the unrecoverable error is encountered. The unrecoverable block is not transferred to the Initiator.
PER	DTE	DCR	TB	Description	

PER	DTE	DCR	TB	Description	
0	0	1	1	Retries are attempted but no error correction (ECC) is applied. Recovered data (if any) is transferred with no <i>Check Condition Status</i> at the end of the transfer.	
				soft error	The transfer length is exhausted. Transferred data includes blocks containing recovered errors.
				hard error	Data transfer stops when the unrecoverable error is encountered. The unrecoverable block is transferred to the Initiator (if data error).
0	1	0	0	Illegal request - DTE cannot be 1 when PER is 0.	
0	1	0	1	Illegal request - DTE cannot be 1 when PER is 0.	
0	1	1	0	Illegal request - DTE cannot be 1 when PER is 0.	
0	1	1	1	Illegal request - DTE cannot be 1 when PER is 0.	
1	0	0	0	The highest error level is reported at the end of transfer (see B.3, "Priority of Error Reporting" on page 278). Retries and error correction are attempted. Recovered and/or corrected data (if any) is transferred with <i>Check Condition Status</i> and Recovered Error sense key set at the end of the transfer.	
				soft error	The transfer length is exhausted. Transferred data includes blocks containing recovered errors.
				hard error	Data transfer stops when the unrecoverable error is encountered. The unrecoverable block is not transferred to the Initiator.
1	0	0	1	The highest error level is reported at the end of transfer (see B.3, "Priority of Error Reporting" on page 278). Retries and error correction are attempted. Recovered and/or corrected data (if any) is transferred with <i>Check Condition Status</i> and Recovered Error sense key set at the end of the transfer.	
				soft error	The transfer length is exhausted. Transferred data includes blocks containing recovered errors.
				hard error	Data transfer stops when the unrecoverable error is encountered. The unrecoverable block is transferred to the Initiator (if data error).
PER	DTE	DCR	TB	Description	

PER	DTE	DCR	TB	Description	
1	0	1	0	The highest error level is reported at the end of transfer (see B.3, "Priority of Error Reporting" on page 278). Retries are attempted but ECC is not applied. Recovered data (if any) is transferred with <i>Check Condition Status</i> and Recovered Error sense key set at the end of the transfer.	
				soft error	The transfer length is exhausted. Transferred data includes blocks containing recovered errors.
				hard error	Data transfer stops when the unrecoverable error is encountered. The unrecoverable block is not transferred to the Initiator.
1	0	1	1	The highest error level is reported at the end of transfer (see B.3, "Priority of Error Reporting" on page 278). Retries are attempted but ECC is not applied. Recovered data (if any) is transferred with <i>Check Condition Status</i> and Recovered Error sense key set at the end of the transfer.	
				soft error	The transfer length is exhausted. Transferred data includes blocks containing recovered errors.
				hard error	Data transfer stops when the unrecoverable error is encountered. The unrecoverable block is transferred to the Initiator (if data error).
1	1	0	0	The highest error level is reported at the end of transfer (see B.3, "Priority of Error Reporting" on page 278). Retries and error correction are attempted. Recovered and/or corrected data (if any) is transferred with <i>Check Condition Status</i> and Recovered Error sense key set at the end of the transfer.	
				soft error	Data transfer stops on the first soft error detected. The recovered error block is returned to the Initiator.
				hard error	Data transfer stops on the unrecovered error. The error block is not returned to the Initiator.
PER	DTE	DCR	TB	Description	

PER	DTE	DCR	TB	Description	
1	1	0	1	The highest error level is reported at the end of transfer (see B.3, “Priority of Error Reporting” on page 278). Retries and error correction are attempted. Recovered and/or corrected data (if any) is transferred with <i>Check Condition Status</i> and Recovered Error sense key set at the end of the transfer.	
				soft error	Data transfer stops on the first soft error detected. The recovered error block is returned to the Initiator.
				hard error	Data transfer stops on the unrecovered error. The unrecovered error block is returned to the Initiator (if data error).
1	1	1	0	The highest error level is reported at the end of transfer (see B.3, “Priority of Error Reporting” on page 278). Retries are attempted but ECC is not applied. Recovered data (if any) is transferred with <i>Check Condition Status</i> and Recovered Error sense key set at the end of the transfer.	
				soft error	Data transfer stops on the first soft error detected. The recovered error block is returned to the Initiator.
				hard error	Data transfer stops on the unrecovered error. The error block is not returned to the Initiator.
1	1	1	1	The highest error level is reported at the end of transfer (see B.3, “Priority of Error Reporting” on page 2780. Retries are attempted but ECC is not applied. Recovered data (if any) is transferred with <i>Check Condition Status</i> and Recovered Error sense key set at the end of the transfer.	
				soft error	Data transfer stops on the first soft error detected. The recovered error block is returned to the Initiator.
				hard error	Data transfer stops on the unrecovered error. The unrecovered error block is returned to the Initiator (if data error).
PER	DTE	DCR	TB	Description	

The **Read Retry Count** sets a limit on the amount of data recovery procedure (DRP) passes the Target attempts when recovering read errors. One pass through DRP involves executing all steps of DRP. (See B.1, “Data Recovery Procedure for Data Field Errors” on page 273 for a description of one DRP pass.) A Read Retry Count of 00h disables all recovery. Read Retry Count set to 0 inhibits Automatic/Recommend Rewrite/Reallocate. A nonzero value for Read Retry Count causes the Target to attempt up to one DRP pass when a medium error occurs during a read operation. The Read Retry Count is used by the Target for errors associated with the transfer of the Initiator's data for the following commands:

- Read(6)
- Read(10)

For all other commands, the Read Retry Count is unused and treated as 1. This description of Read Retry Count depends on the RRC bit (page 0, byte 15, bit 6) being set to 0. If the page 0 RRC bit is set to 1 then the Read Retry Count is the maximum level of recovery performed. (See 1.6.2, “Page 0 - Vendor Unique Parameters” on page 75).

The **Correction Span** is the size, in bits, of the largest data error burst for which data error correction may be attempted. A value of 00h indicates the Target uses the default value.

Note: The Mode Select command accepts a value of 30h or 00h in this field.

The **Head Offset Count** specifies in two's-compliment notation an incremental offset position from the track center the heads are moved. A positive value indicates moving in the direction of increasing logical block addresses. A negative value indicates moving in the direction of decreasing logical block addresses. The Head Offset Count of 00h indicates no offset is supported.

The **Data Strobe Offset Count** specifies in two's-compliment notation an incremental offset position to which the recovered data strobe is adjusted. The value of 00h indicates no offset is supported.

The **Write Retry Count** sets a limit on the amount of data recovery procedure (DRP) passes the Target attempts when recovering write errors. One pass through DRP involves executing all steps of DRP. (See B.1, “Data Recovery Procedure for Data Field Errors” on page 273 for a description of one DRP pass.) A Write Retry Count of 00h disables all recovery. Write Retry Count set to 0 inhibits Automatic/Recommend Rewrite/Reallocate. A nonzero value for Write Retry Count causes the Target to attempt up to one DRP pass when a medium error occurs during a write operation. The Write Retry Count is used by the Target for errors associated with the transfer of the Initiator's data for the following commands:

- Write(6)
- Write(10)
- Write Same
- Write and Verify

For all other commands, the Write Retry Count is unused and treated as 1

The **Recovery Time Limit** specifies in increments of one millisecond the maximum time duration the Target uses for data error recovery procedures. A recovery time limit of 0000h specifies the Target uses the default value of no time limit.

1.6.4 Page 2 - Disconnect/Reconnect Parameters

Table 76. Mode Select Data Format Page 2									
Byte	BIT								
	7	6	5	4	3	2	1	0	
0	RSVD = 0	RSVD = 0	Page Code = 02h						
1	Page Length = 0Eh								
2	Read Buffer Full Ratio								
3	Write Buffer Empty Ratio								
4	(MSB)	Bus Inactivity Limit = 0							
5		(LSB)							
6	(MSB)	Disconnect Time Limit = 0							
7		(LSB)							
8	(MSB)	Connect Time Limit = 0							
9		(LSB)							
10	(MSB)	Maximum Burst Size							
11		(LSB)							
12	Reserved = 0			DIMM	RSVD = 0	DTDC			
13	Reserved = 0								
14	Reserved = 0								
15	Reserved = 0								

Following are parameter options for Page 2 of Mode Select. Refer to Table 76.

An Initiator may use the Identify message to grant the Target the general privilege of disconnecting. (Disconnect requests from the target via Disconnect messages may still be selectively rejected by the Initiator by issuing Message Reject).

The Target uses Mode Select Page 2 parameters to control reconnection during Read and Write operations.

Read Buffer Full Ratio and **Write Buffer Empty Ratio** are the numerators of a fraction whose denominator is 256. This fraction indicates how full (or empty) the Target's data buffer segment should be prior to attempting to reconnect to the SCSI bus. When applying these ratios, the Target rounds down to a whole buffer block. If the ratio is set to 0h (the default), the Target will calculate and use an optimal ratio based on the negotiated transfer rate (width and period), and the formatted block size. If the ratio is set to FFh, the Target does not attempt to reconnect until the buffer segment is completely full (or empty). Both the Read Buffer Full Ratio and the Write Buffer Empty Ratio pertain to the current active notch. For each active notch, as defined in page 0Ch, there are separate Read Buffer Full Ratios and Write Buffer Empty Ratios. When the active notch is zero, the values are applied across all notches.

Reconnecting to a Read Command For a Read command, the reconnect is delayed relative to the availability of the first block in the Target's data buffer segment by the fraction of the Target's data buffer segment size or the data transfer length, whichever is less.

Example: If Read Buffer Full Ratio is C0h (decimal 192) for a ratio of 0.75, the reconnect is delayed until the Target's data buffer segment is 3/4 full or until approximately 3/4 of the remaining transfer length is in the Target's data buffer segment (whichever is smaller).

Reconnecting to Write Command

For a Write command, the Write Buffer Empty Ratio is significant only if the total data transfer length is greater than the size of the Target's data buffer segment. The fraction determines how empty the Target's data buffer segment should be before reconnecting to begin filling the buffer segment again.

Example: If Write Buffer Empty Ratio is C0h (decimal 192) for a ratio of 0.75, the reconnect is delayed until the Target's data buffer segment is 3/4 empty or until approximately 3/4 of the remaining transfer length is empty in the Target's data buffer segment (whichever is smaller).

Choosing Buffer Ratios

For single Initiator/single Target systems, the Initiator should set the buffer ratios to match the SCSI bus instantaneous data transfer rate to the Target's internal data sector transfer rate. (See the *product Functional Specification* for the data rate values.)

$$\text{Buffer Ratio} = 256 \times (\text{Instantaneous SCSI Data Transfer Rate} - \text{Data Sector Transfer Rate}) / \text{Instantaneous SCSI Data Transfer Rate}$$

For systems with SCSI configurations other than single Initiator/single Target, a different ratio may provide better performance.

The **Bus Inactivity Limit** is the maximum time in 100 us increments that the Target is permitted to assert the BSY signal without a REQ/ACK handshake. The value of 00h indicates that there is no limit.

The **Disconnect Time Limit** is the minimum time in 100 us increments that the Target waits after releasing the SCSI bus before attempting reselection. The value of 00h indicates that there is no limit.

The **Connect Time Limit** is the maximum time in 100 us increments that the Target is allowed to use the SCSI bus before disconnecting, if the Initiator has granted the disconnect privilege and it is not restricted by DTDC. The value of 00h indicates that there is no limit.

The **Maximum Burst Size** is the maximum amount of data that the Target transfers during a data phase before disconnecting if the Initiator has granted the disconnect privilege. This value is expressed in increments of 512 bytes (e.g., a value of 0001h means 512 bytes, 0002h means 1024 bytes, etc.). Disconnections attempted by the

Target are on block boundaries only. Therefore, the largest number of blocks of data that the Target transfers before disconnecting is the integer portion of the value of the $(\text{Maximum Burst Size} \times 512) / (\text{Block Length})$ equation. For the case when $(\text{Maximum Burst Size} \times 512)$ is less than the Block Length, the Target will transfer 1 block of data before attempting to disconnect.

A value of 0000h indicates there is no limit on the amount of data transferred per connection.

When a nonzero Maximum Burst Size is in effect, the Maximum Burst Size is the basis of the buffer full/empty ratios. For example, if the Maximum Burst Size field is set to 0010h (15 blocks, if Block Length = 520 bytes) and the Read Buffer Full Ratio is set to C0h (ratio of .75) then the reconnect is delayed until approximately 3/4 of the maximum burst (11 blocks) or approximately 3/4 of the remaining transfer length is in the Target's data buffer segment (whichever is smaller).

Regardless of the value in Maximum Burst Size, the Target disconnects prior to completion of the data phase if the internal data buffer segment becomes empty during a Read command or full during a Write command.

The **Data Transfer Disconnect Control (DTDC)** field defines further restrictions on when a disconnect is permitted.

A value of 00b indicates that DTDC is not used by the Target and the disconnect is controlled by the other fields in this page.

A value of 01b indicates that the target shall not attempt to disconnect once the data transfer of a command has started until all data the command is to transfer has been transferred. The connect time limit and bus inactivity limit are ignored during the data transfer.

The value 10b is reserved.

A value of 11b indicates that the target shall not attempt to disconnect once the data transfer of a command has started until the command is complete. The connect time limit and bus inactivity limit are ignored once data transfer has started.

Note: If DTDC is nonzero and the maximum burst size is nonzero, a CHECK CONDITION status will be returned. The sense key shall be set to ILLEGAL REQUEST and the additional sense code set to ILLEGAL FIELD IN PARAMETER LIST.

The **Disconnect Immediate (DIMM)** bit determines how the DWD and DRD bits from page 0 bytes 2 and 8 will be used. If the DIMM bit is set to 0 then DWD and DRD are used as defined for page 0. If the DIMM bit is set to 1 then the DWD and DRD bits are ignored and the target disconnects immediately after receipt of command.

1.6.5 Page 3 - Format Device Parameters

Table 77. Mode Select Data Format Page 3									
Byte	BIT								
	7	6	5	4	3	2	1	0	
0	RSVD = 0	RSVD = 0	Page Code = 03h						
1	Page Length = 16h (22)								
2	(MSB)	Tracks per Zone							
3		(LSB)							
4	(MSB)	Alternate Sectors per Zone							
5		(LSB)							
6	(MSB)	Alternate Tracks per Zone = 0							
7		(LSB)							
8	(MSB)	Alternate Tracks per Logical Unit = 0							
9		(LSB)							
10	(MSB)	Sectors per Track							
11		(LSB)							
12	(MSB)	Data Bytes per Physical Sector							
13		(LSB)							
14	(MSB)	Interleave = 0001h (or 0000h)							
15		(LSB)							
16	(MSB)	Track Skew Factor							
17		(LSB)							
18	(MSB)	Cylinder skew Factor							
19		(LSB)							
20	SSEC = 0	HSEC = 1	RMB = 0	SURF = 0	Reserved = 0				
21	Reserved = 0								
22	Reserved = 0								
23	Reserved = 0								

The format device page contains parameters which specify the medium format.

This page contains no changeable parameters. If this page is sent during a Mode Select command with parameter values other than those equal to the Default values for the fields that are not Block Length dependant or Current values of fields that are dependant on Block Length, then the Target reports a *Check Condition Status* with a Sense Key of Illegal Request and an additional Sense Code of Invalid Field in Parameter List. Exceptions to this are for the Sectors per Track, Data Bytes per Physical Sector, Interleave, Track Skew Factor and Cylinder skew Factor fields which may have values of zero in them to indicate that the values used are defined by the Target.

This page contains saved parameters but none of the fields are saveable by a Mode Select command with the SP bit set to 1. (The PS bit of Page 3 is set to a 0 on a Mode Sense command.) Even though the data in this page is not saveable, it is valid to send this page on a Mode Select command with SP set to 1.

The **Tracks per Zone** value is the number of tracks in a cylinder. This field is a function of the device Model Number.

The **Alternate Sectors per Zone** a value of 0000h or the value returned by the Mode Sense command may be used. (This is really the average number of alternate sectors per zone of the active notch).

The **Alternate Tracks per Zone** value of 0000h indicates that this is Target specific. (Different zones can contain different amounts of alternate tracks.)

The **Alternate Tracks per Logical Unit** value of 0000h indicates that this is Target specific.

Sectors per Track specifies the number of physical sectors included within each track. This number includes any alternate sectors that may have been allocated and any defective sectors that may have been found and marked defective. This field is a function of the current Block Length and active notch. For more informations see the *product Functional Specification*. A value of zero is also accepted in this field.

Data Bytes per Physical Sector specifies the number of user data bytes per physical sector. The value depends upon the current formatted Block Length. For further information on allowed sector sizes see the *product Functional Specification*. A value of zero is also be accepted in this field.

Interleave values of 1 or 0 are valid. No other interleave is provided.

Track Skew Factor indicates the number of physical sectors between the last logical block of one track and the first logical block on the next sequential track of the same cylinder. This field is a function of the current Block Length and active notch. A value of zero is also accepted in this field.

Cylinder Skew Factor indicates the number of physical sectors between the last logical block of one cylinder and the first logical block on the next cylinder. The value is a function of the current Block Length and active notch.

Note: Actual cylinder skew values are not the same across the entire disk. The value returned is for the outermost cylinders of the active notch. A value of zero is also accepted in this field. The value for unsynchronized spindle motors is always returned. For more information about the actual formatted cylinder skew see 4.5, “Motor Synchronization” on page 225 since the definition of cylinder skew depends upon which of two skewing methods was selected via the Mode Parameter Page 4h RPL field when the last Format Unit command was executed. **Cylinder Skew Factor** can be calculated using the formula for "cylinder skew @OD" as defined in the *product Functional Specification*. The value is a function of current Block Length and active notch.

Note: Actual cylinder skew values are not the same across entire disk. The value returned is for outermost cylinders of the active notch. A value of zero is also accepted in this field. The value for unsynchronized spindle motors is always returned. For more information about the actual formatted cylinder skew see 4.5, “Motor Synchronization” on page 225 since the definition of cylinder skew depends upon which of two skewing methods was selected via the Mode Parameter Page 4h RPL field when the last Format Unit command was executed.

Byte 20 contains the following fields -

SSEC The SSEC bit is set to 0 indicating that the Target does not support soft sector formatting.

- HSEC The HSEC bit is set to 1 indicating that the Target uses hard sector formatting.
- RMB The RMB (Removable Media Bit) is set to 0 indicating that the Target does not support removable media.
- SURF The SURF (Surface) bit set to 0 indicates that the Target allocates progressive addresses to all sectors within a cylinder prior to allocating sector addresses to the next cylinder.

1.6.6 Page 4h - Rigid Disk Drive Geometry Parameters

Table 78. Mode Select Data Format Page 4h												
Byte	BIT											
	7	6	5	4	3	2	1	0				
0	RSVD = 0	RSVD = 0	Page Code = 04h									
1	Page Length = 16h											
2	(MSB)	Number of Cylinders										
3												
4	(LSB)											
5	Number of Heads											
6	(MSB)	Starting Cylinder-Write Precompensation = 0										
7												
8	(LSB)											
9	(MSB)	Starting Cylinder-Reduced Write Current = 0										
10												
11	(LSB)											
12	(MSB)	Drive Step Rate = 0										
13	(LSB)											
14	(MSB)	Landing Zone Cylinder										
15												
16	(LSB)											
17	Reserved = 0					RPL						
18	Rotational Offset											
19	Reserved = 0											
20	(MSB)	Medium Rotation Rate										
21	(LSB)											
22	Reserved = 0											
23	Reserved = 0											

This page describes some physical attributes of the Drive. The RPL field in byte 17 and Rotational Offset field in byte 18 are changeable.

Number of Cylinders defines the number of physical cylinders used for customer data storage. This field is a function of the device Model Number. See the *product Functional Specification* for more information on the number of cylinders.

A value of zero is also accepted in this field.

Number of Heads defines the number of physical heads used for customer data storage. This field is a function of the device Model Number. The exact values are defined in the *product Functional Specification*. A value of zero is also accepted in this field.

Starting Cylinder-Write Precompensation indicates the physical cylinder at which write precompensation begins. The value is set to 000000h indicating that the field is vendor specific.

Starting Cylinder-Reduced Write Current indicates the outer-most physical cylinder to be written with reduced write current. The value is set to 000000h indicating that the field is vendor specific.

Drive Step Rate is set to 0000h to indicate there is no stepper motor.

The **Landing Zone Cylinder** is based on the Device Model Number The Landing Zone can be calculated by adding 200 to the maximum cylinder for the device. Refer to the product Functional Specification for the maximum cylinder value.

The **RPL (Rotational Position Locking)** bits are used to select spindle synchronization modes as defined in Table 79.

Table 79. SCSI/ESDI Synchronized Spindle Modes for 50 and 68 pin connectors				
Mode	RPL Bits (bit1/bit0)	Drive/Release Master Sync	Drive/Receive Slave Sync	Is Rotational Offset allowed ?
No Sync	00	release	(see note 1)	no
Slave Sync	01	release	receive	yes
Master Sync	10	Drive	Drive	no
Master Sync Control	11	Drive	receive	no

Following are definitions of the various modes.

Mode -	Indicates -
No Sync	Spindle synchronization is disabled.
Slave Sync	Spindle synchronization is attempted by receiving the Slave Sync signal as the source signal driven by another device. The Master Sync signal is not driven.
Master Sync	Spindle synchronization is not attempted by this device. This device drives the Slave Sync and Master Sync signals with a pulse once per revolution (Index pulse).
Master Sync Control	Spindle synchronization is attempted by receiving the Slave Sync signal as the source signal driven by another device. The Master Sync signal is driven with a pulse once per revolution (Clock generated pulse, NOT the Index pulse).

See the *product Functional Specification* for descriptions of the electrical and mechanical aspects of the control signals, Slave Sync and Master Sync, and the connectors used to perform spindle synchronization.

When the RPL field is modified as a result of a Mode Select command, the physical spindle synchronization state may change depending on its prior state. That is, performing a mode select of page 4 will immediately change the physical spindle synchronization state if the spindle synchronization mode has been modified. The new RPL value can also take affect (change spindle synchronization state) at start-up sequence initiated via a Start/Stop Unit SCSI command or Auto Start pin being grounded must be executed. See the command description of 1.27, “Start/Stop Unit” on page 150 and section describing 4.5, “Motor Synchronization” on page 225 for more details of how and when spindle synchronization states are altered.

The **Rotational Offset** value is the amount of rotational skew that the Target uses when synchronized. The rotational skew is applied in the retarded direction (lagging the synchronized spindle master control). The value in the field is the numerator of a fractional multiplier that has 256 as its denominator (e.g., a value of 128 indicates a one-half revolution skew). A value of 00h indicates that rotational offset is not used. The rotational offset is only used when the Drive is running in the Slave Sync RPL mode.

The **Medium Rotation Rate** indicates the spindle speed in revolutions per minute. A value of zero is also accepted in this field.

1.6.7 Page 7h - Error Recovery Parameters for Verify

Byte	BIT							
	7	6	5	4	3	2	1	0
0	RSVD = 0	RSVD = 0	Page Code = 07h					
1	Page Length = 0Ah							
2	Reserved = 0				EER=0	PER	DTE=0	DCR
3	Verify Retry Count							
4	Verify Correction Span = 00h							
5	Reserved = 0							
6	Reserved = 0							
7	Reserved = 0							
8	Reserved = 0							
9	Reserved = 0							
10 11	(MSB)	Verify Recovery Time Limit = 0						(LSB)

Following are parameter options for Page 7 of Mode Select. Refer to Table 80.

Page 7 parameters are used by the Target when recovering from and reporting errors associated with the verification of the Initiator's Data for the following commands:

- *Verify*
- *Write and Verify* - the verify portion of the command only.

Since bytes 3-11 are not changeable, the Mode Select Command accepts only the values indicated for bytes 3 - 11.

Byte 2 contains the following fields -

EER This bit is 0 since the Target does not support early recovery.

PER See below for description of bit values.

DTE This bit is 0 since the Target always continues on recovered verify operation errors.

DCR See below for description of bit values.

PER, DTE, and DCR bit settings in page 7 override those of page 1 during *Verify* and the Verify portion of *Write and Verify*. There are only four valid conditions for the PER, DTE, and DCR bits. All other combinations return *Check Condition Status*.

PER	DTE	DCR	Description
0	0	0	Soft errors are not reported. DCR is ignored.
1	0	0	Soft errors are reported. DCR is ignored.
0	0	1	Soft errors are not reported. DCR is ignored.
1	0	1	Soft errors are reported. DCR is ignored.

Soft errors occur when the data is successfully read by one of the appropriate retry steps described in B.1.2, “Verify Commands” on page 275. Also see the description of 1.30, “Verify” on page 154 and 1.33, “Write and Verify” on page 158 for more details on how soft and hard errors are defined for the *Verify* and *Write and Verify* commands.

Verify Retry Count sets a limit on the amount of verify recovery procedure (VRP) passes the Target attempts when recovering verify errors. One pass through VRP involves executing all steps of VRP. (See B.1.2, “Verify Commands” on page 275 for a description of one VRP pass.) A non-zero Verify Retry Count causes the Target to attempt up to one VRP pass when a medium error occurs during a verify operation.

Verify Correction Span specifies the size, in bits, of the largest data error burst for which data error correction may be attempted. A value of 00h indicates the Target does not attempt error correction for verify operations.

Verify Recovery Time Limit specifies in increments of one millisecond the maximum time duration the Target uses for data error recovery procedures to recover data for an individual block. A recovery time limit of 0000h specifies that the Target uses its default value.

1.6.8 Page 8h - Caching Parameters

Table 81. Mode Select Data Format Page 8h								
Byte	BIT							
	7	6	5	4	3	2	1	0
0	RSVD = 0	RSVD = 0	Page Code = 08h					
1	Page Length = 12h							
2	Reserved = 0				WCE	MF	RCD	
3	Demand Read Retention Priority			Write Retention Priority				
4	(MSB)	Disable Pre-fetch Transfer Length						
5		(LSB)						
6	(MSB)	Minimum Pre-fetch						
7		(LSB)						
8	(MSB)	Maximum Pre-fetch						
9		(LSB)						
10	(MSB)	Maximum Pre-fetch Ceiling						
11		(LSB)						
12	RSVD = 0	RSVD = 0	RSVD = 0	Reserved = 0				
13	Number of Cache Segments							
14	(MSB)	Reserved = 0						
15		(LSB)						
16	Reserved = 0							
17	(MSB)	Reserved = 0						
18		Reserved = 0						
19		(LSB)						

Page 8 parameters are used for defining the use of the cache. See 4.9, “Segmented Caching” on page 231 for a more detailed description of cache support. Since bytes 6 and 7 are not changeable, the Mode Select Command accepts only the values indicated in Table 81 for bytes 6 and 7.

The use of the cache is also altered by the setting of Mode Select Page 0, ADC (Adaptive Caching) bit.

Byte 2 contains the following fields -

WCE The WCE (Write Cache Enable) bit of 0 specifies that the Target returns *Good Status* for a Write command only after successfully writing all of the data to the medium. The WCE bit of 1 specifies that the Target may return *Good Status* for a Write command after successfully receiving the data but before writing the data to the medium. (Also see 4.4.1, “Back to Back Writes” on page 225 and 4.9.4, “Write Cache” on page 235 for more information.)

Note: When Write Cache is enabled (WCE = 1), a Synchronize Cache command must be done to assume data is written to the media before powering down the Target.

- MF** The MF (Multiplication Factor) bit determines how the Maximum Pre-fetch parameter is interpreted. If this bit is equal to 0, the parameter is used as is. If the bit is equal to 1, the parameter is multiplied by the number of blocks requested in the Read Command.
- RCD** An RCD (read cache disable) bit of 0 indicates that the Target may return some or all of the data requested by a Read (6) or Read (10) command by accessing the data buffer, not the media (see 4.9, “Segmented Caching” on page 231). An RCD bit of 1 indicates that the Target does not return any of the data requested by a Read (6) or Read (10) command by accessing the data buffer. Rather, all of the data requested is read from the media.

Demand Read Retention Priority sets the Retention Priority of data requested on a Read Command. It may be set to 0h, 1h, or 0Fh as defined below.

Value	Definition
0h	Do not distinguish between Requested Data and Other Data.
1h	Replace Requested Data before Other Data.
0Fh	Replace Other Data before Requested Data.

Where the Value is the Demand Read Retention Priority or Write Retention Priority. Requested Data is the blocks specified in the Read or Write Command. Other Data is data in the cache from any other source (Pre-fetch, Read-Ahead, ...).

If the Read Retention Priority is not set to Fh or if the DPO bit on the Read command is 1, the Requested Data is overwritten by Read-Ahead data.

If the DPO bit is 0 and the Read Retention Priority is set to Fh, the Requested Data is not overwritten with Read-Ahead Data. If the requested transfer is larger than the segment, the Requested Data is overwritten with more Requested Data and there is no Read-Ahead.

Write Retention Priority sets the Retention Priority of data provided on a Write Command. It may be set to 0h, 1h, or 0Fh. See definition of Demand Read Retention Priority above for more details.

Disable Pre-fetch Transfer Length is used to prevent Read-Ahead after Read Commands that are longer than the specified number of blocks. If this parameter is set to 0, a Read-Ahead is not performed.

Minimum Pre-fetch is used to set a lower limit on the number of blocks to Read-Ahead after a Read Command. The value of 0000h indicates that pre-fetching is terminated whenever another command is ready for executing. A value in the range 0001h-FFFEh is the number of blocks prefetched following a read operation that will not be pre-empted by a subsequent command. The actual number of blocks prefetched without interruption may be decreased by other reasons such as space in the cache segment, Maximum Prefetch, and the end of the media. The value of FFFFh indicates that the drive self-adapts the minimum prefetch value. The adaptive minimum prefetch algorithm uses the detected workload seen by the drive to optimize throughput and response time for that workload.

Maximum Pre-fetch is used to set an upper limit on the number of blocks to Read-Ahead after a Read Command. Other factors, such as segment size, Drive size, retention priorities, commands in the queue, the value of Page 0, ADC (Adaptive Caching) bit, and new commands may also limit the Read-Ahead.

Maximum Pre-fetch Ceiling limits the product of the Maximum Pre-fetch and the number of blocks requested in the Read Command.

The **Number of Cache Segments** field is used to select the number of data buffer cache segments. The value entered in this field is rounded down to the nearest value of each segments supported by this Drive. The number of each segments supported by this Drive are 1, 2, 4, 8, 16, and 32.

All segments are of equal size. The buffer space is divided among the segments. (See the *product Functional Specification* for a description of the total buffer and individual buffer segment sizes.)

If Mode Select, Page 0h, ADC bit is on, the Target will default to using 8 cache segments, and may alter the number of segments to optimize drive performance.

Note: Mode Select commands that transfer Page 8h cause the entire cache to be emptied (see 4.9, “Segmented Caching” on page 231).

1.6.9 Page 0Ah - Control Mode Parameters

Table 82. Mode Select Data Format Page 0Ah								
Byte	BIT							
	7	6	5	4	3	2	1	0
0	RSVD = 0	RSVD = 0	Page Code = 0Ah					
1	Page Length = 06h							
2	Reserved = 0						RLEC = 0	
3	Queue Algorithm Modifier			Reserved = 0		QErr	DQue	
4	EECA = 0	Reserved = 0			RAENP - 0	UAAENP - 0	EAENP - 0	
5	Reserved = 0							
6	(MSB)	Ready AEN Holdoff Period = 0						
7		(LSB)						

The Control Mode page (Table 82) provides controls over several features. The features are tagged queuing (see 4.3.2, “Tagged Queuing” on page 222), extended contingent allegiance, asynchronous event notification, and error logging (see 4.6, “Error Logs” on page 228).

Since bytes 2,4-7 are not changeable, the Mode Select Command accepts only the values indicated in Table 82 for bytes 2,4-7.

RLEC (Report Log Exception Condition) bit of 0 specifies that the Target does not report log exception conditions.

Queue Algorithm Modifier specifies restrictions on the algorithm used for re-ordering commands that are tagged with the SIMPLE QUEUE TAG message. The value of zero in this field indicates that the Drive will reorder the execution sequence of queued commands from each initiator such that data integrity is maintained for that initiator. This means that if the transmission of new commands was halted at any time, the final value of all data observable on the medium shall have exactly the same value as it would have if the commands had been executed in the same received sequence without tagged queuing. The restricted reordering value is the default value.

A value of one in the Queue Algorithm Modifier field specifies that the target may reorder the actual execution sequence of the queue in any manner it selects. Any data integrity exposures related to command sequence order are explicitly handled by the initiator through the selection of appropriate commands and queue tag messages.

A value of eight (8) specifies that no reordering be done.

A value of nine (9) specifies that the numeric value of the Queue Tag received with a Simple Queue Tag message determines the order of execution. The larger the value of the queue tag, the earlier the command will be scheduled for execution. The Head of Queue Tag and Ordered Queue Tag messages are still honored. Any data integrity exposures related to command sequence order are explicitly handled by the initiator through the selection of appropriate commands and queue tag messages.

QErr (Queue Error management) bit of 0 specifies that the Target suspends execution of queued and active commands from any Initiator which receives a *Check Condition Status* until the pending sense data is cleared. Those commands still queued or suspended after the Target has returned *Check Condition Status*, continue execution in a normal manner when the pending sense data is cleared.

A QErr bit of 1 specifies that the Target aborts queued and active commands when the Target returns *Check Condition Status*. An active Start Unit command or an active Format Unit command are not aborted and continue to execute when an Initiator returns *Check Condition Status*. The setting of the QEMC bit (see 1.6.2, “Page 0 - Vendor Unique Parameters” on page 75) determines if the commands from all Initiators or just the Initiator receiving the *Check Condition Status* are aborted.

When the QErr bit is 1 and the QEMC bit is 0, all active commands and all queued commands from the Initiator receiving the *Check Condition Status* are aborted. Commands from other Initiator are unaffected.

When the QErr bit is 1 and the QEMC bit is 1, all active commands (except Start Unit and Format Unit) and all queued commands from all Initiators are aborted when the Target returns *Check Condition Status*. When this condition occurs a *Unit Attention* will be generated for each Initiator that had an I/O process aborted except for the Initiator that received the *Check Condition Status*. The sense key will be set to *Unit Attention* and the additional sense code will be set to *Commands Cleared by Another Initiator*.

DQue (Disable Queuing) bit of 0 specifies that tagged queuing is enabled. A DQue bit of 1 specifies that tagged queuing is disabled. Any queued commands for that I_T_L nexus are aborted. No status is sent for aborted commands. Any subsequent queue tag message received are rejected with a MESSAGE REJECT message and the I/O process is executed as an untagged command.

EECA (Enable Extended Contingent Allegiance) bit of 0 specifies that extended contingent allegiance is disabled.

The **RAENP**, **UAAENP**, and **EAENP** bits enable specific events to be reported via the asynchronous event notification protocol. Since the Target does not create asynchronous event notifications, all three bits are always 0.

Ready AEN Holdoff Period specifies the minimum time in milliseconds after the Target starts its initialization sequence that it delays before attempting to issue an asynchronous event notification. The value of 0000h indicates that this field is not supported (because asynchronous event notification is not supported).

1.6.10 Page 0Ch - Notch Parameters

Table 83. Mode Select Data Format Page 0Ch									
Byte	BIT								
	7	6	5	4	3	2	1	0	
0	RSVD = 0	RSVD = 0	Page Code = 0Ch						
1	Page Length = 16h								
0	ND = 1	LPN = 0	Reserved = 00h						
3	Reserved = 0								
4 5	(MSB)	Maximum number of notches (LSB)							
6 7	(MSB)	Active notch (LSB)							
8 11	(MSB)	Starting Boundary (LSB)							
12 15	(MSB)	Ending Boundary (LSB)							
16 23	(MSB)	Pages Notched = 000000000000100Ch (LSB)							

The notch page contains parameters for direct-access devices which implement a variable number of blocks per cylinder. Each section of the logical unit with a different number of blocks per cylinder is referred to as a notch. The only field that is changeable is the "Active notch" field.

"**ND**" = **1** meaning that this drive is a notched drive.

"**LPN**" = **0** meaning that the notches are based upon physical parameters of the drive (cylinder #), not logical parameters.

"**Maximum Number of Notches**" is the number of notches the drive can support. The value returned is model dependent.

"**Active Notch**" indicates which notch subsequent Mode Select/Sense command parameters pertain to. A value of 0 is used for parameter values which apply to all notches. Values greater than zero specify the notch number, where notch 1 is the outer most notch.

The following mode parameters are based on the current active notch:

- Page 02h
 - Read Buffer Empty Ratio.
 - Write Buffer Full Ratio.
- Page 03h
 - Alternate Sectors Per Zone.
 - Sectors Per Track.
 - Track Skew Factor.
 - Cylinder Skew Factor.

"Starting Boundary" contains the first physical location of the active notch. The first three bytes is the cylinder number and the last byte is the head. The value sent in this field is ignored.

"Ending Boundary" contains the last physical location of the active notch. The first three bytes is the cylinder number and the last byte is the head. The value sent in this field is ignored.

"Pages Notched" is a bit map of the mode page codes that indicates which pages contain parameters that may be different for different notches. The most significant bit of this field corresponds to page code 3Fh and the least significant bit corresponds to page code 00h. If a bit is one, then the corresponding mode page contains parameters that may be different for different notches. If the bit is zero, then the corresponding mode page contain parameters that are constant for all notches.

1.7 Mode Sense (6)

Table 84. Mode Sense Command Descriptor Block								
Byte	BIT							
	7	6	5	4	3	2	1	0
0	Operation Code = 1Ah							
1	LUN			RSVD = 0	DBD	Reserved = 0		
2	PC		Page Code					
3	Reserved = 0							
4	Allocation Length							
5	VU = 0		Reserved = 0				Flag	Link

The Mode Sense command provides a means for the Target to report various device parameters to Initiators. It is the complement to the Mode Select command.

If the DBD (Disable Block Descriptor) bit is zero, the target will return the Block Descriptor. If the DBD bit is set to 1, the target will not return the Block Descriptor.

PC (Page Control) defines the type of Page Parameter values to be returned.

Page Code indicates which page(s) to return.

Page Code of 3Fh is a request for the Target to return all supported pages. Otherwise, a single page may be selected. If an unsupported page is selected, the command is terminated with a *Check Condition Status* and available sense of ***Illegal Request/Invalid Field in CDB***.

If a Page Code of 3Fh is used, Mode Sense returns the pages in ascending order with one exception. Page 0 is always returned last in response to a *Mode Sense* command.

The Allocation Length field indicates the maximum number of bytes the Initiator has set aside for the Data In phase. A value of zero is not considered an error. If the allocation length is smaller than the number of bytes of data the target has available to send to the initiator, then that portion of the data up to the allocation length is sent. This may result in only a portion of a multiple byte field being sent.

Note: An Initiator may issue the Mode Sense command to determine Mode Select parameters that are:

- Current values
- Changeable values
- Default values
- Saved values

Fields not supported by the Target have values set to zero.

The types of parameters returned for the different setting of the PC bits are as follows:

PC Meaning

0 0 Report current values.

The definition of current values changes as the Drive progresses from power-up through command execution. The following list defines the various sources of current values:

- Initially following power-up but before the media is accessed, the default values become current.
- Once the media can be accessed, the saved values are read from the Reserved Area and become current.

Note: The Target does not process the Mode Select command until the completion of start-up sequence. Therefore, an Initiator cannot modify the current values prior to the saved values being read from the Reserved Area, unless a problem prohibited the saved parameters from being read successfully.

- Following the completion of start-up, execution of the Mode Select command can modify the current values.

Note: Those parameters associated with format are not considered current and are not saved until the successful completion of a "Format Unit Command".

- In addition, the current values take on the saved values after a reset if the parameters were saved.

If the Page Code is 3Fh, then all pages implemented by the Target are returned to the Initiator with fields and bit values set to current values.

If the Page Code is not 3Fh, the page defined by the Page Code, if supported by the Target, is returned with fields and bits set to current values.

0 1 Report Changeable Values.

Reporting changeable values presents a bit mask for Mode parameter bytes (i.e. bytes following the page length field) indicating which fields are changeable. For a value field such as the buffer ratios in page 2, the bit field does not indicate the range of supported values but rather that the field is simply supported.

If the Page Code is 3Fh, all pages implemented by the Target are returned with bits and fields that may be changed by the Initiator set to one.

If the Page Code is not 3Fh, the page defined by Page Code, if supported, is returned with bits and fields that may be changed by the Initiator set to one.

Note: No field in Page 3 is changeable, but certain fields implicitly have varying values depending on the current formatted Block Length.

1 0 Report Default Values

The default values do not require a media access. See 1.6, "Mode Select (6)" on page 70 for the Target's default values.

If the Page Code is 3Fh, all pages implemented by the Target are returned with bits and fields set to default values.

If the Page Code is not 3Fh, the page defined by Page Code (if supported) is returned with bits and fields set to default values.

1.1 Report Saved Values

The saved values reside in the Reserved Area of the Drive.

Returned values can vary depending upon whether or not those parameters can be successfully read from the Reserved Area or if they have ever been saved. The possible saved values returned are either

- Values saved in the Reserved Area during the last Mode Select command that had the SP bit on, or
- Values identical to the default values if an error prohibits the saved parameters from being read from the Reserved Area of the disk during a start-up sequence, or
- Values identical to the default values if never saved.

If the Page Code is 3Fh, all pages implemented by the Target are returned with bits and fields set to their saved values.

If the Page Code is not 3Fh, the page defined by Page Code, if supported, is returned with bits and fields set to their saved values.

Note: When Page 3 saved values are requested, the Target will return parameter values equivalent to the current values.

1.7.1 Mode Sense Data Format (of Header & Block Descriptor)

The following diagram depicts the format of the Mode Sense data available from the Target.

Byte	BIT							
	7	6	5	4	3	2	1	0
0	Sense Data Length							
1	Medium Type = 0							
2	WP	Reserved = 0		DPOFUA - 1	Reserved = 0			
3	Block Descriptor Length = 08h							

Byte	BIT							
	7	6	5	4	3	2	1	0
0	Density Code = 0							
1	(MSB) Number of Blocks (LSB)							
2								
3								
4	Reserved = 0							
5	(MSB) Block Length (LSB)							
6								
7								

See the text describing 1.6.1.1, “Header” on page 72 for a description of the Medium Type and WP fields.

The DPOFUA bit value of 1 indicates that the Target supports the FUA and DPO bits in the Read and Write Commands. See 4.9, “Segmented Caching” on page 231 for detailed information on this support.

The Block Descriptor Length field value of 8 indicates that only a single block descriptor follows.

The Number of Blocks field specifies the number of blocks currently available to the Initiator. It is a function of the Number of Blocks specified by the Mode Sense command and the current block length. Refer to the product Functional Specification for more information about capacity.

If the Number of Blocks is FFFFFFFh then the number of blocks is greater than FFFFFFFEh. In this case the Read Capacity command may be used to determine the actual number of blocks for the device.

The Block Length field is dependant on how the media is currently formatted.

1.7.2 Mode Sense Data Format (of All Pages)

Table 87. Mode Sense Data Page 00h										
Byte	BIT									
	7	6	5	4	3	2	1	0		
0	PS = 1	RSVD = 0	Page Code = 0							
1	Page Length = 0Eh									
2	QPE	UQE	DWD	Reserved = 0						
3	ASDPE	DPW	CMDAC	RPF AE	DOTF	ignored	RRNDE	CPE		
4	Ignored									
5	ignored	TCC	DSN	FRDD	DPSDP	ignored	CAEN	LITF		
6	ignored									
7	ignored									
8	ignored	ADC	QEMC	DRD	LED Mode					
9	ignored									
10	Command Aging Time Limit (HI)									
11	Command Aging Time Limit (LO)									
12	QPE-2 for read operations									
13	QPE-2 for write operations									
14	DRRT	DNR	DUASS	RARRED	ignored					
15	RTP	RRC	FCERT	RCPF	ignored					

Table 88. Mode Sense Data Page 01h										
Byte	BIT									
	7	6	5	4	3	2	1	0		
0	PS = 1	RSVD = 0	Page Code = 01h							
1	Page Length = 0Ah									
2	AWRE	ARRE	TB	RC	EER = 0	PER	DTE	DCR		
3	Read Retry Count									
4	Correction Span = 30h									
5	Head Offset Count = 0									
6	Data Strobe Offset Count = 0									
7	Reserved = 0									
8	Write Retry Count									
9	Reserved = 0									
10	(MSB)	Recovery Time Limit = 0								
11		(LSB)								

Table 89. Mode Sense Data Page 02h								
Byte	BIT							
	7	6	5	4	3	2	1	0
0	PS = 1	RSVD = 0	Page Code = 02h					
1	Page Length = 0Eh							
2	Read Buffer Full Ratio							
3	Write Buffer Empty Ratio							
4	(MSB)	Bus Inactivity Limit = 0						
5		(LSB)						
6	(MSB)	Disconnect Time Limit = 0						
7		(LSB)						
8	(MSB)	Connect Time Limit = 0						
9		(LSB)						
10	(MSB)	Maximum Burst Size						
11		(LSB)						
12	ignored				DIMM	RSVD = 0	DTDC	
13	Reserved = 0							
14	Reserved = 0							
15	Reserved = 0							

Table 90. Mode Sense Data Page 03h								
Byte	BIT							
	7	6	5	4	3	2	1	0
0	PS = 0	RSVD = 0	Page Code = 03h					
1	Page Length = 16h							
2 3	(MSB)	Tracks per Zone (LSB)						
4 5	(MSB)	Alternate Sectors per Zone (LSB)						
6 7	(MSB)	Alternate Tracks per Zone = 0 (LSB)						
8 9	(MSB)	Alternate Tracks per Logical Unit = 0 (LSB)						
10 11	(MSB)	Sectors per Track (LSB)						
12 13	(MSB)	Data Bytes per Physical Sector (LSB)						
14 15	(MSB)	Interleave = 0001h (LSB)						
16 17	(MSB)	Track Skew Factor (LSB)						
18 19	(MSB)	Cylinder skew Factor (LSB)						
20	SSEC = 0	HSEC = 1	RMB = 0	SURF = 0	Reserved = 0			
21	Reserved = 0							
22	Reserved = 0							
23	Reserved = 0							

Table 91. Mode Sense Data Page 04h									
Byte	BIT								
	7	6	5	4	3	2	1	0	
0	PS = 1	RSVD = 0	Page Code = 04h						
1	Page Length = 16h								
2	(MSB)								
3	Number of Cylinders								
4	(LSB)								
5	Number of Heads								
6	(MSB)								
7	Starting Cylinder-Write Precompensation = 0								
8	(LSB)								
9	(MSB)								
10	Starting Cylinder-Reduced Write Current = 0								
11	(LSB)								
12	(MSB)								
13	Drive Step Rate = 0								
14	(MSB)								
15	Landing Zone Cylinder								
16	(LSB)								
17	Reserved = 0						RPL		
18	Rotational Offset								
19	Reserved = 0								
20	(MSB)								
21	Medium Rotation Rate								
22	(LSB)								
22	Reserved = 0								
23	Reserved = 0								

Table 92. Mode Sense Data Page 07h									
Byte	BIT								
	7	6	5	4	3	2	1	0	
0	PS = 1	RSVD = 0	Page Code = 07h						
1	Page Length = 0Ah								
2	Reserved = 0				EER=0	PER	DTE=0	DCR	
3	Verify Retry Count = 01h								
4	Verify Correction Span = 0								
5	Reserved = 0								
6	Reserved = 0								
7	Reserved = 0								
8	Reserved = 0								
9	Reserved = 0								
10	(MSB)								
11	Verify Recovery Time Limit = 0								
11	(LSB)								

Table 93. Mode Sense Data Page 08h								
Byte	BIT							
	7	6	5	4	3	2	1	0
0	PS = 1	RSVD = 0	Page Code = 08h					
1	Page Length = 12h							
2	Reserved = 0					WCE	MF	RCD
3	Demand Read Retention Priority				Write Retention Priority			
4	(MSB)	Disable Pre-fetch Transfer Length						
5		(LSB)						
6	(MSB)	Minimum Pre-fetch						
7		(LSB)						
8	(MSB)	Maximum Pre-fetch						
9		(LSB)						
10	(MSB)	Maximum Pre-fetch Ceiling						
11		(LSB)						
12	RSVD = 0	RSVD = 0	RSVD = 0	Reserved = 0				
13	Number of Cache Segments							
14	(MSB)	Reserved = 0						
15		(LSB)						
16	Reserved = 0							
17	(MSB)	Reserved = 0						
18		Reserved = 0						
19		(LSB)						

Table 94. Mode Sense Data Page 0Ah								
Byte	BIT							
	7	6	5	4	3	2	1	0
0	PS = 1	RSVD = 0	Page Code = 0Ah					
1	Page Length = 06h							
2	Reserved = 0							RLEC = 0
3	Queue Algorithm Modifier				Reserved = 0		QErr	DQue
4	ECCA = 0	Reserved = 0				RAENP = 0	UAAENP = 0	EAENP = 0
5	Reserved = 0							
6	(MSB)	Ready AEN Holdoff Period = 0						
7		(LSB)						

Table 95. Mode Sense Data Format Page 0Ch								
Byte	BIT							
	7	6	5	4	3	2	1	0
0	PS = 1	RSVD = 0	Page Code = 0Ch					
1	Page Length = 16h							
2	ND = 1	LPN = 0	Reserved = 00h					
3	Reserved = 0							
4 5	(MSB)	Maximum number of notches (LSB)						
6 7	(MSB)	Active notch (LSB)						
8 11	(MSB)	Starting Boundary (LSB)						
12 15	(MSB)	Ending Boundary (LSB)						
16 23	(MSB)	Pages Notched = 00000000000100Ch (LSB)						

The Parameters Saveable (PS) bit is set to 1 for pages 0, 1, 2, 4, 7, 8, 0Ah, and 0Ch to indicate that some of the parameters of those pages can be saved.

The Parameters Saveable (PS) bit is set to 0 for page 3 to indicate that none of the parameters of that page can be saved with a Mode Select command. They can, however, change as a result of a Format command.

The Page Length byte value of each page returned by the Target indicates the number of Mode parameter bytes returned. Bytes 1 and 0 are not included.

The bit descriptions for all of the fields of all of the pages are described in the Mode Select section (see 1.6, “Mode Select (6)” on page 70).

1.8 Pre-Fetch

Table 96. Pre-Fetch Command Descriptor Block								
Byte	BIT							
	7	6	5	4	3	2	1	0
0	Operation Code = 34h							
1	LUN			Reserved = 0			Immed	RelAdr = 0
2	(MSB) Logical Block Address (LSB)							
3								
4								
5								
6	Reserved = 0							
7	(MSB) Transfer Length (LSB)							
8								
9	VU = 0			Reserved = 0			Flag	Link

The Pre-Fetch command requests the target to transfer the specified logical blocks to the cache. No data is transferred to the initiator.

The transfer length field specifies the number of contiguous blocks of data that are to be transferred into the cache. A transfer length of zero indicates that blocks are to be transferred into the cache until the segment is filled or there are no more blocks on the media.

If the Immediate (Immed) bit of the CDB is zero:

- If an error occurs while reading, error recovery procedures are attempted. The Drive returns *Good Status* or *Check Condition Status* based on the setting of the MODE SELECT Page 1 parameters.
- If there is enough room in the segment for all of the Requested Data or if the Transfer Length is zero and no error occurs while reading, the Drive returns *Condition Met Status* when the command completes.
- If there is not enough room in the segment, the Transfer Length is not zero, and no error occurred while reading, the Drive returns *Good Status* when the command completes.

If the Immediate (Immed) bit of the CDB is one:

- If there is enough room in the segment for all of the Requested Data or if the Transfer Length is zero, the Drive returns *Condition Met Status* as soon as the CDB is verified.
- If there is not enough room in the segment and the Transfer Length is not zero, the Drive returns *Good Status* as soon as the CDB is verified.
- The reading of data is handled the same as Read-Ahead operation. This implies the prefetch may be terminated upon receipt of another command, (see 4.9.3, “Read-Ahead” on page 231) for more details.
- If an error is encountered:
 1. The Target terminates the Pre-Fetch operation and does not attempt to recover the data.

2. The error is not reported to the Initiator for the current command. (The error will be reported during the next command if the next command is a Read command that requests the block which encountered the error.)
3. The blocks which were successfully read prior to the block in error are retained in the cache.

The RelAdr (relative address) bit must be zero. The Drive does not support relative addressing. If RelAdr is set to 1, *Check Condition Status* is returned with a Sense Key of Illegal Request and additional sense code of Invalid Field in CDB.

1.9 Read (6)

Byte	BIT							
	7	6	5	4	3	2	1	0
0	Operation Code = 08h							
1	LUN			(MSB)	LBA			
2	Logical Block Address							
3	Logical Block Address (LSB)							
4	Transfer Length							
5	VU = 0		Reserved = 0				Flag	Link

The Read (6) command requests that the Target transfer the specified number of blocks of data to the Initiator starting at the specified logical block address.

The logical block address specifies where the read operation is to begin.

Transfer length may be a value from 0 to 255 where 0 implies a length of 256 blocks.

Errors are handled by ERP (error recovery procedures) (see B.1, “Data Recovery Procedure for Data Field Errors” on page 273). ERPs are controlled by the error recovery parameters (see 1.6.3, “Page 1 - Error Recovery Parameters” on page 83).

Note: The 6 byte command has only 21 bits for address for LBAs. The 21 bits allows for $2 \times 10^{(21)}$ lbas (2,097,152). The 10 byte command should be used to read LBAs which require more bits. At 512 byte blocks, this only allows access to 1.048 Gigabytes. The 10 byte command must be used to read lbas which require more bits.

1.10 Read (10)

Table 98. Read (10) Command Descriptor Block								
Byte	BIT							
	7	6	5	4	3	2	1	0
0	Operation Code = 28h							
1	LUN			DPO	FUA	Reserved = 0		RelAdr = 0
2	(MSB) Logical Block Address (LSB)							
3								
4								
5								
6	Reserved = 0							
7	(MSB) Transfer Length (LSB)							
8								
9	VU = 0			Reserved = 0			Flag	Link

The Read (10) command requests that the Target transfer the specified number of blocks of data to the Initiator starting at the specified logical block address.

The logical block address specifies where the read operation is to begin.

A DPO (Disable Page Out) bit of 1 indicates that the data accessed by this command is to be assigned the lowest priority for being written into or retained by the cache. A DPO bit of 1 overrides any retention priority specified in the Mode Select Page 8 Caching Parameters. A DPO bit of 0 indicates the priority is determined by the retention priority. See 1.6.8, “Page 8h - Caching Parameters” on page 102 and 4.9, “Segmented Caching” on page 231.

The initiator should set the DPO bit when the blocks read by this command are not likely to be read again in the near future.

A FUA (Force Unit Access) bit of 1 indicates that the data is read from the media and not from the cache. A FUA bit of 0 allows the data to be read from either the media or the cache.

The RelAdr (Relative Address) bit must be 0. Relative addressing is not supported. If RelAdr is set to 1, Check Condition Status is returned with a Sense Key of Illegal Request and additional sense code of Invalid Field in CDB.

If the transfer length is zero, the seek occurs, but no data is transferred. This condition is not considered an error. If read ahead is enabled, a read ahead is started after the seek completes (see 4.9.3, “Read-Ahead” on page 231).

1.11 Read Buffer

Table 99. Read Buffer Command Descriptor Block								
Byte	BIT							
	7	6	5	4	3	2	1	0
0	Operation Code = 3Ch							
1	LUN			Reserved = 0		Mode		
2	Buffer ID = 0							
3	(MSB)							
4	Buffer Offset							
5								
6	(MSB)							
7	Allocation Length							
8								
9	VU = 0		Reserved = 0				Flag	Link

The Read Buffer command is used in conjunction with the Write Buffer command to test the SCSI bus and target memory. The only valid Modes are:

- 000b Read combined header and data
- 010b Data mode
- 011b Descriptor Mode

If any modes other than shown above are specified, then *Check Condition Status* is returned with a Sense Key of ***Illegal Request*** and additional sense code of ***Invalid Field in CDB***.

- Mode = 000b Read combined header and data

In this mode Read Buffer transfers a four-byte header and the specified amount of data from the data buffer.

Byte 0 of the header is reserved. Bytes 1 through 3 contain the buffer capacity.

The Buffer ID and Buffer Offset fields must be zero. Receipt of a non-zero Buffer ID or a non-zero Buffer Offset results in *Check Condition Status* with sense key of ***Illegal Request*** and additional Sense Code of ***Invalid Field in CDB***.

The Allocation Length includes the length of the header. The target terminates the Data-In phase when the number of bytes specified in the Allocation Length (header plus the data) have been transferred or when the header and all available data have been transferred to the Initiator, whichever is less.

- Mode = 010b Data mode

In this mode Read Buffer transfers the specified amount of data from the data buffer.

The Buffer ID field must be zero. Receipt of a non-zero Buffer ID results in *Check Condition Status* with sense key of ***Illegal Request*** and additional Sense Code of ***Invalid Field in CDB***.

The Buffer Offset field specifies the byte offset within the buffer from which the data will be transferred. The Buffer Offset is required to be less than the buffer capacity. An offset greater than or equal to the buffer capacity results in *Check*

Condition Status with Sense key of **Illegal Request** and additional Sense Code of **Invalid Field in CDB**.

Note: The buffer capacity can be determined using Read Buffer mode 000b or mode 011b.

The target terminates the Data-In phase when the number of bytes specified in the Allocation Length have been transferred or when all available data (from the specified offset to the end of the buffer) have been transferred to the Initiator, whichever is less.

- Mode = 011b Descriptor mode

In this mode, Read Buffer transfers a four-byte header. Header information is returned for the buffer specified by the buffer ID. If there is no buffer associated with the specified buffer ID, Read Buffer transfers all zeros in the header.

Byte 0 of the header is reserved. Bytes 1 through 3 contain the buffer capacity.

The Buffer Offset fields must be zero. Receipt of a non-zero Buffer Offset results in Check Condition Status with a sense key of ILLEGAL REQUEST and an additional sense code of INVALID FIELD IN CDB.

The allocation length should be set to four or greater. An allocation length of less than four indicates no data is transferred.

1.12 Read Capacity

Table 100. Read Capacity Command Descriptor Block									
Byte	BIT								
	7	6	5	4	3	2	1	0	
0	Operation Code = 25h								
1	LUN				Reserved = 0				
2	(MSB) Logical Block Address (LSB)								
3									
4									
5									
6	Reserved = 0								
7	Reserved = 0								
8	Reserved = 0							PMI	
9	VU = 0			Reserved = 0				Flag	Link

The Read Capacity command returns information to the Initiator regarding the capacity of the LUN.

A Partial Medium Indicator (PMI) bit of 0 indicates that the information returned is the logical block address (LBA) and block length (in bytes) of the last logical block on the LUN. The LBA bytes of the command descriptor block must be set to zero for this option.

A PMI bit of 1 indicates that the information returned is the LBA and block length (in bytes) of the last logical block on the same cylinder as the LBA specified in the command descriptor block. This option provides an indication of the amount of contiguous space beyond or equal to the LBA specified without the need for a seek.

Following is the format of the data returned to the Initiator in the Data In phase.

Table 101. Format of Read Capacity Data Returned								
Byte	BIT							
	7	6	5	4	3	2	1	0
0	(MSB) Logical Block Address (LSB)							
1								
2								
3								
4	(MSB) Block Length (LSB)							
5								
6								
7								

,* the 12 byte version of the command.

1.13 Read Defect Data (10)

Byte	BIT							
	7	6	5	4	3	2	1	0
0	Operation Code = 37h							
1	LUN			Reserved = 0				
2	Reserved = 0			PList	GList	Defect List Format		
3-6	Reserved = 0							
7	(MSB) Allocation Length (LSB)							
8								
9	VU = 0			Reserved = 0			Flag	Link

The Read Defect Data command requests that the Target transfer the medium defect data to the Initiator. The Target does not return defects that exist in the Reserved area.

A PList bit of one requests that the Target return the Primary defect list. A PList bit of zero requests that the Target not return the Primary defect list.

A GList bit of one requests that the Target return the Grown defect list. A GList bit of zero requests that the Target not return the Grown defect list.

A PList bit of one and a GList bit of one requests that the Target return both the Primary and Grown defect lists. The Target returns the Primary list first with defects in ascending order. The Target returns the Grown list second with defects in the order that the Reassign Block command, the Auto-Reassign function, and the Format Unit command (with Defect List) added them to the list.

The Defect List Format field indicates the preferred format of defect data to be returned to the Initiator.

Preferred Defect List Format	Returned Defect List Format
Block (000b)	Physical Sector
Bytes from Index (100b)	Bytes from Index
Physical Sector (101b)	Physical Sector
Vendor Unique (110b)	Physical Sector
Reserved (001b)	Physical Sector
Reserved (010b)	Physical Sector
Reserved (011b)	Physical Sector
Reserved (111b)	Physical Sector

If the Preferred Defect List Format is not the Returned Defect List Format, the Target transfers the defect data then terminates the command with Check Condition status. The sense key is set to Recovered Error and the additional sense code is set to Defect List Not Found.

The Allocation Length field specifies the maximum number of bytes that the Initiator has allocated for receiving the defect data. An Allocation length of zero is not an error and in this case no defect data will be transferred.

The Read Defect Data defect list contains a four byte header, followed by zero or more defect descriptors.

Table 103. Read Defect Data - Header								
Byte	BIT							
	7	6	5	4	3	2	1	0
0	Reserved = 0							
1	Reserved = 0			PList	GList	Defect List Format		
2	(MSB) Defect List Length (LSB)							
3								

Table 104. Read Defect Data - Defect Descriptor(s)								
Byte	BIT							
	7	6	5	4	3	2	1	0
0 - 7	Defect Descriptor 0							
8n - 8n+7	Defect Descriptor n							

If a Requested List is empty then the Target will return Good status. A PList bit of one indicates that the data returned contains the primary defect list. A PList bit of zero indicates that the data returned does not contain the primary defect list.

A GList bit of one indicates that the data returned contains the Grown defect list. A GList bit of zero indicates that the data returned does not contain the Grown defect list.

Defect List Format indicates the format of the defect descriptors returned to the Initiator.

Defect list length specifies the length in bytes of the defect descriptors that follow. The defect list length is equal to eight times the number of defect descriptors.

If the allocation length is insufficient to transfer the four byte header and all of the defect descriptors, the defect list length is not adjusted to reflect the truncation. The Target does not create Check Condition status. The Initiator should compare the defect list length with the allocation length to determine if a partial list was received.

Note: An Initiator can determine the length of the defect list by issuing the Read Defect Data command with an allocation length of four. The Target returns the defect list header which contains the length of the defect list.

Normally the target will set the defect list length field to the amount of space needed to contain the entire defect list. However, the Target is capable of building a defect list with a length such that the entire list cannot be transferred using the maximum allocation length. If the defect list grows beyond 8191 entries the defect data cannot be transferred with an allocation length of FFFFh. The Target will transfer a partial defect list and return Check Condition status with the sense key set to Recovered Error and the Additional Sense Code is set to partial defect list transferred. The

defect list length will be set to FFF8h, indicating the maximum number of defect descriptors which can be transferred. Defects beyond this number can not be read by an initiator.

The formats for the defect descriptor are shown in the following tables.

Table 105. Defect Descriptor - Bytes From Index Format								
Byte	BIT							
	7	6	5	4	3	2	1	0
0	(MSB) Cylinder Number of Defect (LSB)							
1								
2								
3	Head Number of Defect							
4	(MSB) Defect Bytes From Index (LSB)							
5								
6								
7								

Each defect descriptor for the Bytes From Index format specifies the middle of a sector-sized defect location on the medium. Each defect descriptor is comprised of the cylinder number of defect, the head number of defect, and the defect bytes from index.

The middle byte of a physical sector is calculated as follows:

$$(\text{sector number} * \text{user bytes/sector}) + (1/2 * \text{user bytes/sector})$$

Table 106. Defect Descriptor - Physical Sector Format								
Byte	BIT							
	7	6	5	4	3	2	1	0
0	(MSB) Cylinder Number of Defect (LSB)							
1								
2								
3	Head Number of Defect							
4	(MSB) Defective Sector Number (LSB)							
5								
6								
7								

Each defect descriptor for the Physical Sector format specifies a sector-size defect location comprised of the cylinder number of defect, the head number of defect, and the defect sector number.

1.14 Read Defect Data (12)

Table 107. Read Defect Data Command Descriptor Block							
Byte	BIT						
	7	6	5	4	3	2	1
0	Operation Code = B7h						
1	LUN		PList	GList	Defect List Format		
2	Reserved = 0						
3	Reserved = 0						
4	Reserved = 0						
5	Reserved = 0						
6-9	(MSB)	Allocation Length					(LSB)
10	Reserved = 0						
11	VU = 0		Reserved = 0			Flag	Link

The Read Defect Data command requests that the Target transfer the medium defect data to the Initiator. The Target does not return defects that exist in the Reserved area.

A PList bit of one requests that the Target return the Primary defect list. A PList bit of zero requests that the Target not return the Primary defect list.

A GList bit of one requests that the Target return the Grown defect list. A GList bit of zero requests that the Target not return the Grown defect list.

A PList bit of one and a GList bit of one requests that the Target return both the Primary and Grown defect lists. The Target returns the Primary list first and defects in ascending order. The Target returns the Grown list second and defects in the order that the Reassign Block command, the Auto-Reassign function, and the Format Unit command (with Defect List) added them to the list.

The Defect List Format field indicates the preferred format of defect data to be returned to the Initiator.

Preferred Defect List Format	Returned Defect List Format
Block (000b)	Physical Sector
Bytes from Index (100b)	Bytes from Index
Physical Sector (101b)	Physical Sector
Vendor Unique (110b)	Physical Sector
Reserved (001b)	Physical Sector
Reserved (010b)	Physical Sector
Reserved (011b)	Physical Sector
Reserved (111b)	Physical Sector

If the Preferred Defect List Format is not the Returned Defect List Format, the Target transfers the defect data then terminates the command with Check Condition status. The sense key is set to Recovered Error and the additional sense code is set to Defect List Not Found.

The Allocation Length field specifies the maximum number of bytes that the Initiator has allocated for receiving the defect data. An Allocation length of zero is not an error and in this case no defect data will be transferred.

The Read Defect Data defect list contains an eight byte header, followed by zero or more defect descriptors.

Byte	BIT							
	7	6	5	4	3	2	1	0
0	Reserved = 0							
1	Reserved = 0			PList	GList	Defect List Format		
2	Reserved = 0							
3	Reserved = 0							
4-7	(MSB)	Defect List Length						(LSB)

Byte	BIT							
	7	6	5	4	3	2	1	0
0 - 7	Defect Descriptor 0							
8n - 8n+7	Defect Descriptor n							

If a Requested List is empty then the Target will return Good status. A PList bit of one indicates that the data returned contains the primary defect list. A PList bit of zero indicates that the data returned does not contain the primary defect list.

A GList bit of one indicates that the data returned contains the Grown defect list. A GList bit of zero indicates that the data returned does not contain the Grown defect list.

Defect List Format indicates the format of the defect descriptors returned to the Initiator.

Defect list length specifies the length in bytes of the defect descriptors that follow. The defect list length is equal to eight times the number of defect descriptors.

If the allocation length is insufficient to transfer the eight byte header and all of the defect descriptors, the defect list length is not adjusted to reflect the truncation. The Target does not create Check Condition status. The Initiator should compare the defect list length with the allocation length to determine if a partial list was received.

Note: An Initiator can determine the length of the defect list by issuing the Read Defect Data command with an allocation length of eight. The Target returns the defect list header which contains the length of the defect list.

The formats for the defect descriptor are shown in the following tables.

Table 110. Defect Descriptor - Bytes From Index Format								
Byte	BIT							
	7	6	5	4	3	2	1	0
0	(MSB) Cylinder Number of Defect (LSB)							
1								
2								
3	Head Number of Defect							
4	(MSB) Defect Bytes From Index (LSB)							
5								
6								
7								

Each defect descriptor for the Bytes From Index format specifies the middle of a sector-sized defect location on the medium. Each defect descriptor is comprised of the cylinder number of defect, the head number of defect, and the defect bytes from index.

The middle byte of a physical sector is calculated as follows:
 $(\text{sector number} * \text{user bytes/sector}) + (1/2 * \text{user bytes/sector})$

Table 111. Defect Descriptor - Physical Sector Format								
Byte	BIT							
	7	6	5	4	3	2	1	0
0	(MSB) Cylinder Number of Defect (LSB)							
1								
2								
3	Head Number of Defect							
4	(MSB) Defective Sector Number (LSB)							
5								
6								
7								

Each defect descriptor for the Physical Sector format specifies a sector-size defect location comprised of the cylinder number of defect, the head number of defect, and the defect sector number.

1.15 Read Long

Table 112. Read Long Command Descriptor Block								
Byte	BIT							
	7	6	5	4	3	2	1	0
0	Operation Code = 3Eh							
1	LUN			Reserved = 0			CORRCT = 0	RelAdr = 0
2	(MSB) Logical Block Address (LSB)							
3								
4								
5								
6	Reserved = 0							
7	(MSB) Byte Transfer Length (LSB)							
8								
9	VU = 0		Reserved = 0				Flag	Link

The Read Long command requests that the target transfer data to the Initiator. The data returned by the Read Long command consists of the data bytes followed by the LRC and ECC bytes recorded on the medium.

The CORRCT (corrected) bit must be zero. If CORRCT is set to 1, Check Condition Status is returned with a Sense Key of Illegal Request and additional sense code of Invalid Field in CDB. The Drive does not attempt data correction. The Drive will however, attempt to retry the command an internally specified number of times.

The RelAdr (relative address) bit must be zero. The Drive does not support relative addressing. If RelAdr is set to 1, Check Condition Status is returned with a Sense Key of Illegal Request and additional sense code of Invalid Field in CDB.

The logical block address field specifies the logical block at which the read operation occurs.

The byte transfer length field must exactly specify the number of bytes of data that are available for transfer. If the value does not exactly match the available data length, the command terminates with Check Condition status, a sense key set to Illegal Request, and an additional sense code set to Invalid Field in CDB. The valid and ILI bits are set to one and the information field is set to the difference (residue) of the requested length minus the actual length in bytes. Negative values are indicated by two's complement notation.

The transfer length is calculated as follows:

$$\text{transfer length} = \text{logical block size} + (20 * n),$$

where n is the number of physical sectors per LBA.

If the byte transfer length is zero, the seek occurs, but no data is transferred. This condition is not considered an error.

The data read by this command is not read from nor retained in the cache.

1.16 Reassign Blocks

Byte	BIT							
	7	6	5	4	3	2	1	0
0	Operation Code = 07h							
1	LUN			Reserved = 0				
2	Reserved = 0							
3	Reserved = 0							
4	Reserved = 0							
5	VU = 0		Reserved = 0				Flag	Link

The Reassign Blocks command requests the Target to reassign Logical Blocks to available spare locations. The Logical Block Addresses are transferred to the Target during the Data Out phase.

A physical sector of the LBA in the Reassign Blocks Data Descriptor is reassigned. Additional physical sectors residing in the affected data area may also be reassigned.

All spare physical sectors on each cylinder are located on the last track of that cylinder. As new spares are needed, the next spare in order is used. If all spares on that cylinder are filled, the first available spare of the next cylinder is used. This continues for a maximum of three cylinders beyond the location of the Defective Logical Block Address in the Reassign Blocks Data Descriptor. If there are not enough available spares within three cylinders to reassign the initial and all additional physical sectors, the Drive returns Check Condition and builds sense data for No Defect Spare Location Available.

Execution of this command causes movement of data adjacent to the LBA specified in the Reassign Block Data Descriptor. The data moved consists of sectors that reside on the track containing the LBA reassigned and all sectors on subsequent tracks required to perform the reassign, a maximum of three consecutive cylinders of data is allowed to be moved. The sequential order of all logical blocks is maintained during this movement.

During the reading of the affected data area, an internal reallocate log is used to determine if additional physical sectors need reassignment. If the DNR bit on Mode page 0 is set to zero then additional physical sectors determined to need reassignment are also reassigned. If the DNR bit on Mode page 0 is set to one then no LBAs other than the target LBA are reassigned.

Upon successful completion of this command, the location of all physical sectors reassigned during the command is added to the Glist.

If the command is interrupted by a reset or power outage, the command automatically resumes the reassignment when the Drive's Bring-up Sequence is executed or restarted. Refer to 4.18, "Bring-Up Sequence" on page 243 for more information.

If the reassignment fails to complete successfully, the Target enters a degraded mode of operation. Writing to the data area affected is prohibited. For more information on the degraded mode and when reassign operations can get restarted see 4.1.9, "Degraded Mode" on page 208.

All data during a reassign command is preserved except for the data residing at the Defective Logical Block Address described in the Reassign Blocks Data Descriptor. The Initiator should read and save the data of the requested LBA before the Reassign Blocks command is issued and restore the data after the Reassign Blocks command completes successfully.

The ID of sectors reassigned is rewritten to flag the physical sector defective and cannot be accessed.

Following is the format of the data sent by the Initiator during the Data Out phase. SCSI bus data phase retries are not supported.

Table 114. Format of Reassign Blocks Data - Header								
Byte	BIT							
	7	6	5	4	3	2	1	0
0	Reserved = 0							
1	Reserved = 0							
2	(MSB)	Defect List length						
3		(LSB)						

Table 115. Format of Reassign Blocks Data - Descriptor(s)								
Byte	BIT							
	7	6	5	4	3	2	1	0
0 - 3	Reassign Blocks Data Descriptor 0							
4n - 4n+3	Reassign Blocks Data Descriptor n							

Table 116. Format of Reassign Blocks Data - Descriptor								
Byte	BIT							
	7	6	5	4	3	2	1	0
0	(MSB)	Defective Logical Block Address						
1								
2								
3	(LSB)							

The Reassign Blocks defect list contains a 4-byte header followed by the Reassign Blocks Data Descriptors. The header Defect List Length is a multiple of 4, where 16 is its maximum value. The Reassign Blocks command requests the reassignment of up to four logical blocks per command. The length of each defect descriptor is 4 bytes. The descriptors may be sent in any order. When more than one Descriptor is used, multiple defective logical block addresses will be reassigned individually in descending order (and may not be in the order given).

1.17 Receive Diagnostic Results

Table 117. Receive Diagnostic Results Command Descriptor Block								
Byte	BIT							
	7	6	5	4	3	2	1	0
0	Operation Code = 1Ch							
1	LUN			Reserved = 0				
2	Reserved = 0							
3	(MSB) Allocation Length (LSB)							
4								
5	VU = 0		Reserved = 0				Flag	Link

The Receive Diagnostic Results command requests that analysis data requested by a Send Diagnostics command be sent to the initiator.

Allocation Length specifies the amount of data to be returned to the initiator. No bytes are transferred if the allocation length is zero. This condition is not considered an error. The target terminates the Data In phase when all available diagnostic data has been transferred or when the number of bytes transferred equals the allocation length.

1.17.1 Supported Diagnostic Pages - Receive Diagnostics

Table 118. Supported Diagnostic Pages - Receive Diagnostics								
Byte	BIT							
	7	6	5	4	3	2	1	0
0	Page Code = 00h							
1	Reserved = 0							
2	(MSB) Page Length = 2 (LSB)							
3								
4	First Supported Page Code = 00h							
5	Second Supported Page Code = 40h							

The supported diagnostic page returns a list of supported pages in ascending order.

1.17.2 Translate Address Page - Receive Diagnostics

The translate address page allows the initiator to translate a logical block address or physical sector address to the other format. The address to be translated is passed to the target with the Send Diagnostic command and the results are returned to the initiator by the Receive Diagnostics commands' translate address page.

Table 119. Translate Address Page - Receive Diagnostics								
Byte	BIT							
	7	6	5	4	3	2	1	0
0	Page Code = 40h							
1	Reserved = 0							
2	(MSB) Page Length (LSB)							
3								
4	Reserved = 0					Supplied Format		
5	Rarea	Altsec	Altrk	Reserved = 0		Translated Format		
6 - 13	Translated Address 1							
n - n+7	Translated Address n (if required)							

The page begins with a four-byte page header which specifies the page code and length, followed by two bytes which describe the translated address followed by zero or more translated addresses.

The Page Code field is equal to 40h.

The Page Length field specifies the length of the parameter bytes which follow.

The Supplied format field contains the value from the Send Diagnostics command supplied format field. The target supports 000b (Block Format) and 101b (Physical Sector Format).

The Translated format field contains the value from the Send Diagnostics command translate format field. Valid values are 000b (Block Format) and 101b (Physical Sector Format).

A reserved area (Rarea) bit of one indicates that all or part of the translated address falls within a reserved area of the medium. If the Rarea bit is one a translated address will not be returned. An Rarea bit of zero indicates that no part of the translated address falls within a reserved area of the medium.

An alternate sector (Altsec) bit of one indicates that the translated address is physically located in an alternate sector of the medium. An Altsec bit of zero indicates that no part of the translated address is located in an alternate sector of the medium.

An alternate track (Altrk) bit of one indicates that all or part of the translated address is located on an alternate track of the medium. An Altrk bit of zero indicates that no of the translated address is on an alternate track of the medium.

The translated address field contains the result the target obtained by translating the address supplied by the initiator in the previous Send Diagnostic command. This field shall be in the format specified in the translate format field. The Physical Sector format is described in Table 7 on page 28. If the Logical Block format is specified the block address shall be in the first four bytes of the field and the remaining bytes shall be zero.

If the address to be translated covers more than one address after translation (multiple physical sectors per logical block) the target will return all possible addresses which are contained for the address to be translated.

1.18 Release (6)

Byte	BIT							
	7	6	5	4	3	2	1	0
0	Operation Code = 17h							
1	LUN			3rdPty	3rd Party ID			Ext = 0
2	Reservation Identification							
3	Reserved = 0							
4	Reserved = 0							
5	VU = 0		Reserved = 0				Flag	Link

The Release command is used to release a LUN previously reserved. It is not an error for an Initiator to attempt to release a reservation that is not currently active. In this case, the Drive returns Good status without altering the reservation.

Extents are not supported by the Drive. The Ext (Extent) bit must be zero and the Reservation Identification field is ignored. If the Ext bit is not zero, *Check Condition Status* is returned with a Sense Key of ***Illegal Request*** and additional sense code of ***Invalid Field in CDB***

If the 3rdPty bit is zero, then the third-party release option is not requested. If the 3rdPty bit is one, then the Target releases the LUN, but only if the reservation was made using the third-party reservation option and the 3rd Party ID is the ID of the initiator that made the reservation. (see 1.21, “Reserve (6)” on page 141) (see 4.1.10, “Command Processing While Reserved” on page 219)

1.19 Release (10)

Table 121. Release Command Descriptor Block								
Byte	BIT							
	7	6	5	4	3	2	1	0
0	Operation Code = 57h							
1	LUN		3rdPty	Reserved			Ext = 0	
2	Reservation Identification							
3	Third Party Device ID							
4	Reserved = 0							
5	Reserved = 0							
6	Reserved = 0							
7	Reserved = 0							
8	Reserved = 0							
9	VU = 0		Reserved = 0			Flag	Link	

The Release command is used to release a LUN previously reserved. It is not an error for an Initiator to attempt to release a reservation that is not currently active. In this case, the Drive returns Good status without altering the reservation.

Extents are not supported by the Drive. The Ext (Extent) bit must be zero and the Reservation Identification field is ignored. If the Ext bit is not zero, *Check Condition Status* is returned with a Sense Key of ***Illegal Request*** and additional sense code of ***Invalid Field in CDB***

If the 3rdPty bit is zero, then the third-party release option is not requested. If the 3rdPty bit is one, then the Target releases the LUN, but only if the reservation was made using the third-party reservation option and the 3rd Party ID is the ID of the initiator that made the reservation. (see 1.21, “Reserve (6)” on page 141) (see 4.1.10, “Command Processing While Reserved” on page 219)

1.20 Request Sense

Byte	BIT							
	7	6	5	4	3	2	1	0
0	Operation Code = 03h							
1	LUN			Reserved = 0				
2	Reserved = 0							
3	Reserved = 0							
4	Allocation Length							
5	VU = 0		Reserved = 0				Flag	Link

The Request Sense command requests that the Target transfer sense data to the Initiator.

Sense data is valid for a Check Condition status returned on the prior command and for most unexpected bus free conditions. The sense data is preserved by the Target for the Initiator until retrieved by the Request Sense command or until any other command is received for the same LUN from the same Initiator that issued the command resulting in the Check Condition status. In the case of the single Initiator option, the Target assumes that the Request Sense command is from the same Initiator.

If a Request Sense command is received and Unit Attention is active, the Drive reports any pending sense data and preserves the Unit Attention Condition (see 4.1.5, “Unit Attention Condition” on page 202). If there is no pending sense data for conditions other than a Unit Attention, the sense data for the Unit Attention is returned and the Unit Attention condition is cleared.

The Target transfers all of the sense data up to the number of bytes allocated by the Initiator. No bytes are transferred if the allocation length is 0; this is not an error condition.

Note: For support of the Drive, a minimum allocation length of 32 bytes is required. However, for a generalized SCSI Initiator design, only an allocation of 255 bytes (FFh) ensures that sense data is not lost.

For a description of the sense data returned, see Appendix A, “SCSI Sense Data Format” on page 247.

Separate sense data is maintained for each Initiator.

If a Request Sense command is issued with an invalid LUN, sense data is returned indicating an illegal request due to the invalid LUN.

The Request Sense command returns the Check Condition status only to report fatal errors for the Request Sense command. Possible fatal errors include:

- Nonzero reserved bit in the command descriptor block
- Unrecovered SCSI bus parity error
- Incorrect Initiator Connection

Note: The Request Sense Command is not queued. For more information, see 4.3, “Command Queuing” on page 221.

1.21 Reserve (6)

Byte	BIT							
	7	6	5	4	3	2	1	0
0	Operation Code = 16h							
1	LUN			3rdPty	3rd Party ID			Ext = 0
2	Reservation Identification							
3	(MSB) Extent List Length = 0							
4	(LSB)							
5	VU = 0		Reserved = 0			Flag	Link	

The Reserve command is used to reserve a LUN for an Initiator. This reservation can be either for the Initiator sending the command or for a third party as specified by the Initiator.

Extents are not supported by the Drive. The Ext bit must be 0. If Ext bit is set to 1, *Check Condition Status* is returned with a Sense Key of **Illegal Request** and additional sense code of **Invalid Field in CDB**. The Reservation Identification and Extent List Length fields are ignored.

The Reserve command requests that the entire Lun be reserved for the Initiator until;

- The reservation is superseded by another valid Reserve command from the Initiator that made the reservation.
- The reservation is released by a Release command from the same Initiator.
- A hard Reset condition occurs.
- A Bus Device Reset message is received from any Initiator.
- A power off/on cycle occurs.

The 3rdPty bit of 0 indicates that the Initiator that issued the the Reserve command is the Initiator for which the LUN is reserved.

The 3rdPty bit of 1 indicates that this is a third-party reservation . The 3rd Party ID field specifies the ID of the third party for which the LUN is reserved. A reservation made with the 3rdPty bit of 1 and the 3rd Party ID field set to the Initiator that issued this Reserve command is considered equivalent to a reservation made with the 3rdPty bit set to 0.

Only the Initiator that issued the Reserve command for a LUN may release the LUN, regardless of the 3rdPty option. This Initiator may also release the LUN by issuing another Reserve command. This superseding Reserve command releases the previous reservation when the new reservation is granted (see 4.1.10, “Command Processing While Reserved” on page 219).

Reservation queuing is not supported by the Drive. If a LUN is reserved and a Reserve command is issued from a different initiator, the Target responds with a reservation Conflict.

1.22 Reserve (10)

Table 124. Reserve Command Descriptor Block								
Byte	BIT							
	7	6	5	4	3	2	1	0
0	Operation Code = 56h							
1	LUN		3rdPty	Reserved			Ext = 0	
2	Reservation Identification							
3	Third Party Device ID							
4	Reserved = 0							
5	Reserved = 0							
6	Reserved = 0							
7	(MSB) Extent List Length = 0 (LSB)							
8								
9	VU = 0		Reserved = 0			Flag	Link	

The Reserve command is used to reserve a LUN for an Initiator. This reservation can be either for the Initiator sending the command or for a third party as specified by the Initiator.

Extents are not supported by the Drive. The Ext bit must be 0. If Ext bit is set to 1, *Check Condition Status* is returned with a Sense Key of **Illegal Request** and additional sense code of **Invalid Field in CDB**. The Reservation Identification and Extent List Length fields are ignored.

The Reserve command requests that the entire Lun be reserved for the Initiator until;

- The reservation is superseded by another valid Reserve command from the Initiator that made the reservation.
- The reservation is released by a Release command from the same Initiator.
- A hard Reset condition occurs.
- A Bus Device Reset message is received from any Initiator.
- A power off/on cycle occurs.

The 3rdPty bit of 0 indicates that the Initiator that issued the the Reserve command is the Initiator for which the LUN is reserved.

The 3rdPty bit of 1 indicates that this is a third-party reservation . The 3rd Party ID byte specifies the ID of the third party for which the LUN is reserved. A reservation made with the 3rdPty bit of 1 and the 3rd Party ID byte set to the Initiator that issued this Reserve command is considered equivalent to a reservation made with the 3rdPty bit set to 0.

Only the Initiator that issued the Reserve command for a LUN may release the LUN, regardless of the 3rdPty option. This Initiator may also release the LUN by issuing another Reserve command. This superseding Reserve command releases the previous reservation when the new reservation is granted (see 4.1.10, “Command Processing While Reserved” on page 219).

Reservation queuing is not supported by the Drive. If a LUN is reserved and a Reserve command is issued from a different initiator, the Target responds with a reservation Conflict.

1.23 Rezero Unit

Byte	BIT							
	7	6	5	4	3	2	1	0
0	Operation Code = 01h							
1	LUN			Reserved = 0				
2	Reserved = 0							
3	Reserved = 0							
4	Reserved = 0							
5	VU = 0		Reserved = 0				Flag	Link

The Rezero Unit command causes the Drive to reposition heads to the cylinder containing Logical Block Address 0 and optionally force execution of certain internal periodic activities.

If the TCC bit is set (see 1.6.2, “Page 0 - Vendor Unique Parameters” on page 75) then periodic internal activities will be executed as part of the Rezero Unit command. By forcing these activities and resetting the associated timers the Initiator can prevent unpredictable response time due to these internal activities. The periodic activities will resume when the timers expire, thus the Initiator must reissue this command periodically as needed.

1.24 Seek (6)

Table 126. Seek (6) Command Descriptor Block								
Byte	BIT							
	7	6	5	4	3	2	1	0
0	Operation Code = 0Bh							
1	LUN			(MSB)	LBA.			
2	Logical Block Address							
3	Logical Block Address (LSB)							
4	Reserved = 0							
5	VU = 0		Reserved = 0				Flag	Link

The Seek Command causes the Drive to seek to the track that contains the specified LBA. If the LBA is greater than the value returned by the Read Capacity command, the Drive returns a Check Condition status with a sense key of Illegal Request and an additional sense code of Invalid Field in CDB.

1.25 Seek (10)

Table 127. Seek (10) Command Descriptor Block								
Byte	BIT							
	7	6	5	4	3	2	1	0
0	Operation Code = 2Bh							
1	LUN			Reserved = 0				
2	(MSB)	Logical Block Address						
3								
4								
5	(LSB)							
6-8	Reserved = 0							
9	VU = 0		Reserved = 0				Flag	Link

The Seek Command causes the Drive to seek to the track that contains the specified LBA. If the LBA is greater than the value returned by the Read Capacity command, the Drive returns a Check Condition status with a sense key of Illegal Request and an additional sense code of Invalid Field in CDB.

1.26 Send Diagnostic

Byte	BIT							
	7	6	5	4	3	2	1	0
0	Operation Code = 1Dh							
1	LUN			PF	RSVD = 0	Self Test	Dev Ofl	Unit Ofl
2	Reserved = 0							
3	(MSB) Parameter List Length (LSB)							
4								
5	VU = 0		Reserved = 0			Flag	Link	

The Send Diagnostic command requests that the Target perform self diagnostic tests.

The PF (Page Format) Bit set to one specifies that the Send Diagnostic parameters conform to the page structure as specified in the ANSI SCSI Standard.

If the SelfTest bit is set to one the the Parameter List Length must be zero.

If the SelfTest bit is one the following self-tests will be performed if the spindle motor is running and up to speed.

- RAM checksum Test
- ROM checksum Test
- Data Buffer Test
- Seek Test
- Head Offset Test
- Read Test(all heads)
- Write Test(all heads)
- Cyclic Redundancy Code (CRC) Test
- Error Correction Code (ECC) Test
- Longitudinal Redundancy Code (LRC) Test

In addition to the above tests the Target will resume an interrupted Reassign Blocks command or Auto Reallocate.

All of the above must complete successfully for the Target to return Good status. If a test fails, the command terminates, an interrupted Reassign Blocks command or Auto Reallocate is not resumed, Check Condition status will be returned and the Target will be in Degraded Mode (see 4.1.9, “Degraded Mode” on page 208).

If the SelfTest bit is zero the target will perform the diagnostic operation specified in the passed parameter list.

If the SelfTest bit is zero, the parameter list length specifies the length in bytes of the parameter list to be transferred from the initiator to the target. If the length is zero, no data will be transferred. This is not an error. If the specified length results in truncation of the supported page, the target will return *Check Condition Status* with a Sense Key of ***Illegal Request/Invalid Field in CDB***. The target supports the Translate Address Page, Page Code 40h.

The PF bit may be 0 or 1 if the SelfTest bit is zero.

The DevOfl and UnitOfl bits are ignored because they are not applicable for this device.

1.26.1 Send Diagnostics Page 00h

Table 129. Supported Diagnostics Pages - Send Diagnostics								
Byte	BIT							
	7	6	5	4	3	2	1	0
0	Page Code = 00h							
1	Reserved = 0							
2	(MSB) Page Length = 00h (LSB)							
3								

The supported diagnostics page allows the initiator to request that a list of supported diagnostic pages be returned on the next Receive Diagnostic Results command.

The page code field is 00h.

The page length field is 00h. If the page length field is not 0, the command will terminate with *Check Condition Status*. The sense key shall be set to ILLEGAL REQUEST and the additional sense code set to ILLEGAL FIELD IN PARAMETER LIST.

1.26.2 Send Diagnostics Page 40h

The translate address page allows the initiator to translate a logical block address or physical sector address to the other format. The address to be translated is passed to the target with the Send Diagnostic command and the results are returned to the initiator by the Receive Diagnostics Results command.

The target will read the parameter list from the initiator, and if no errors are detected in the parameter list, Good Status will be returned. The data translation will be performed upon receipt of the Receive Diagnostic Results Command.

Table 130. Translate Address Page - Send Diagnostics								
Byte	BIT							
	7	6	5	4	3	2	1	0
0	Page Code = 40h							
1	Reserved = 0							
2	(MSB) Page Length = 000Ah (LSB)							
3								
4	Reserved = 0				Supplied Format			
5	Reserved = 0				Translate Format			
6 - 13	Address to Translate							

The page begins with a four-byte page header which specifies the page code and length, followed by two bytes which describe the translated address followed by the address to be translated.

The Page Code field is 40h.

The Page Length field specifies the length of the parameter bytes which follow, equal to ten.

The Supplied format field specifies the format of the address to be translated. The target supports 000b (Block Format) and 101b (Physical Sector Format).

The Translated format field specifies which format the initiator would like the address to be translated to. Valid values are the same as for the Supplied format.

If an invalid Supplied or Translated format field is passed, or if the Supplied format is the same as the Translated format field, the target will terminate the command with *Check Condition Status*. The sense key shall be set to ILLEGAL REQUEST and the additional sense code set to ILLEGAL FIELD IN PARAMETER LIST.

The address to translate field contains a single address for the target to translate. The format of this field depends on the value in the supplied format field. The Physical Sector format is described in Table 7 on page 28. If the logical block format is the supplied format, the block address must be in the first four bytes of this field with the remaining bytes set to zero.

1.27 Start/Stop Unit

Byte	BIT							
	7	6	5	4	3	2	1	0
0	Operation Code = 1Bh							
1	LUN			Reserved = 0				Immed
2	Reserved = 0							
3	Reserved = 0							
4	Reserved = 0						LoEj = 0	Start
5	VU = 0		Reserved = 0				Flag	Link

The Start/Stop Unit command requests that the Target enable/disable the LUN for further media access operations. Specifically, the Start/Stop Unit command spins up/stops the spindle motor.

Request Sense may be used to determine when the LUN is ready after the start-up sequence has completed.

- See 4.1.6, “Command Processing During Start-up and Format Operations” on page 205 for a description of how the Target reacts while the motor is performing the start-up sequence.
- Once the start-up has successfully completed, Request Sense returns sense data with a Sense key of *No Sense*.

When Immed is set to 1:

- Status is returned immediately.
- The Link bit must equal zero.
- *Good Status* is returned unless a higher priority status is pending (see 4.1.1, “Priority of SCSI Status Byte Reporting” on page 197).
- If there is an error during start-up, the command issued after the error occurred returns a *Check Condition Status*. The Request Sense command then returns a deferred error sense data combination (see 4.1.8, “Deferred Error Condition” on page 207).

When Immed is set to 0:

- Status is returned at the end of the operation (after start-up is complete).
- If an error occurs, Start Unit returns a *Check Condition Status*. The Request Sense command then returns a *Medium Error* or *Hardware Error* sense key (see Appendix A, “SCSI Sense Data Format” on page 247).

A Start bit of 1 requests the LUN be made ready for use. Being made 'ready for use' involves making sure that all steps of the start-up sequence are performed (see 4.18, “Bring-Up Sequence” on page 243). After the spindle motor reaches nominal operating speed, the Target performs the remainder of the start-up sequence if necessary. The individual elements of the start-up sequence are only executed if they have not been executed previously.

Note: When Start = 1 the Target will check the motor synchronization mode in the RPL field in Page 4 - Rigid Disk Drive Geometry Page and change the spindle state of operation if any RPL bits are set. See 4.5, “Motor Synchronization” on page 225 for details on error reporting and Unit Attention condition generation.

Start set to 0 requests that the logical unit be stopped (media cannot be accessed by the Initiator). The Target performs an implicit Synchronize Cache command for the entire media prior to executing the Start/Stop Unit command.

The LoEj (Load or Eject) bit must be zero. Removable media is not supported. If LoEj is set to 1, *Check Condition Status* is returned with a Sense Key of ***Illegal Request*** and additional sense code of ***Invalid Field in CDB***

1.28 Synchronize Cache

Table 132. Synchronize Cache Command Descriptor Block								
Byte	BIT							
	7	6	5	4	3	2	1	0
0	Operation Code = 35h							
1	LUN			Reserved = 0			Immed	RelAdr = 0
2	(MSB) Logical Block Address (LSB)							
3								
4								
5								
6	Reserved = 0							
7	(MSB) Number of Blocks (LSB)							
8								
9	VU = 0			Reserved = 0			Flag	Link

The Synchronize Cache command ensures that logical blocks in the cache, have their most recent data value recorded on the media. If more recent data in the specified logical block range exists in the cache than on the media, then the data from the cache is written to the media.

The Logical Block Address specifies where the operation is to begin.

The number of blocks field specifies the total number of contiguous logical blocks within the range. A number of blocks of zero indicates that all remaining logical blocks on the logical unit shall be within the range.

The RelAdr (relative address) bit must be zero. The target does not support relative addressing. If RelAdr is set to 1, *Check Condition Status* is returned with a Sense Key of **Illegal Request** and additional sense code of **Invalid Field in CDB**

An Immed (Immediate) bit of 0 indicates that the Target completes the operation before returning *Good Status*. An Immed bit of 1 indicates that the Target return status as soon as the command descriptor block has been verified.

1.29 Test Unit Ready

Byte	BIT							
	7	6	5	4	3	2	1	0
0	Operation Code = 00h							
1	LUN			Reserved = 0				
2	Reserved = 0							
3	Reserved = 0							
4	Reserved = 0							
5	VU = 0		Reserved = 0				Flag	Link

The Test Unit Ready command allows the Initiator to check if the logical unit is ready.

If the logical unit can accept any supported medium-access command without returning Check Condition status with a Sense key of Not Ready (provided the LUN is not Busy or Reserved) then this command returns Good status. If a Degraded Mode condition currently exists for the logical unit, then this command returns Check Condition status with a sense key of Not Ready, unless a higher priority response is required. (see B.3, “Priority of Error Reporting” on page 278).

The Test Unit Ready command is not intended as a diagnostic. No self-analysis is performed by the logical unit as a result of this command.

1.30 Verify

Table 134. Verify Command Descriptor Block								
Byte	BIT							
	7	6	5	4	3	2	1	0
0	Operation Code = 2Fh							
1	LUN			DPO	Reserved = 0		BytChk	RelAdr = 0
2	(MSB) Logical Block Address (LSB)							
3								
4								
5								
6	Reserved = 0							
7	(MSB) Verification Length (LSB)							
8								
9	VU = 0			Reserved = 0			Flag	Link

The Verify command requests that the Target verify the data written on the medium. With a verification length of 0, the seek occurs but no data is verified. This condition is not considered an error.

The Logical Block Address specifies where the operation is to begin.

A BytChk bit of zero causes the Drive to do an ECC check on the specified range. If an ECC check is detected on all re-reads and the data was not corrected (either because it was uncorrectable or the correction was not attempted), a Check Condition status is returned with a Medium Error sense key.

A BytChk bit of one causes the Drive to do a byte-by-byte compare of data on the Drive to data sent by the initiator during the data-out phase. If an ECC check persists then Check Condition status is returned with Medium Error sense key. If there is no ECC check and a compare error is detected then Check Condition status is returned with a Miscompare sense key.

DRP actions for this command are controlled by Mode parameters in 1.6.7, “Page 7h - Error Recovery Parameters for Verify” on page 100. The actual DRP steps are defined in B.1.2, “Verify Commands” on page 275. Miscompare errors are not retried.

If caching is enabled, the command performs an implied Force Unit Access (FUA) and an implied Synchronize Cache before starting the verify. This insures that the medium, not the cache, is being verified.

The command stops on Check Condition and reports the LBA in error. The command must be reissued, starting with the next LBA, to verify the remainder of the Drive.

The Verification Length is the number of blocks to check.

The data (if any) from the data-out phase and the data from the media are not retained in the cache. Therefore, the DPO bit has no effect on this command and is ignored.

The RelAdr (Relative Address) bit must be 0. Relative addressing is not supported. If RelAdr is set to 1, Check Condition Status is returned with a Sense Key of Illegal Request and additional sense code of Invalid Field in CDB.

1.31 Write (6)

Byte	BIT							
	7	6	5	4	3	2	1	0
0	Operation Code = 0Ah							
1	LUN			(MSB)	LBA			
2	Logical Block Address							
3	Logical Block Address (LSB)							
4	Transfer Length							
5	VU = 0			Reserved = 0			Flag	Link

The Write (6) command requests that the Target write the specified number of blocks of data from the Initiator to the LUN starting at the specified logical block address.

Transfer length may be a value from 0 to 255 where 0 implies a length of 256 blocks.

Errors are handled by ERP (error recovery procedures) (see B.1, “Data Recovery Procedure for Data Field Errors” on page 273). ERPs are controlled by the error recovery parameters (see 1.6.3, “Page 1 - Error Recovery Parameters” on page 83).

Note: The 6 byte command has only 21 bits of address for LBAs. The 21 bits allows for $2 \times 10^{(21)}$ LBAs. (2,097,152) The 10 byte command should be used to write LBAs which require more bits.

1.32 Write (10)

Table 136. Write (10) Command Descriptor Block								
Byte	BIT							
	7	6	5	4	3	2	1	0
0	Operation Code = 2Ah							
1	LUN			DPO	FUA	Reserved = 0		RelAdr = 0
2	(MSB) Logical Block Address (LSB)							
3								
4								
5								
6	Reserved = 0							
7	(MSB) Transfer Length (LSB)							
8								
9	VU = 0			Reserved = 0			Flag	Link

The Write (10) command requests that the Target write the specified number of blocks of data from the Initiator to the LUN starting at the specified logical block address.

A FUA (Force Unit Access) bit of 1 indicates the Target must write the logical blocks of data to media before returning *Good Status*. A FUA bit of 0 indicates the Target may return *Good Status* prior to writing the logical blocks of data to the media.

A DPO (Disable Page Out) bit of 1 indicates that the data accessed by this command is to be assigned the lowest priority for being written into or retained by the cache. A DPO bit of 1 overrides any retention priority specified in the Mode Select Page 8 Caching Parameters. A DPO bit of 0 indicates the priority is determined by the retention priority. See 1.6.8, “Page 8h - Caching Parameters” on page 102 and 4.9, “Segmented Caching” on page 231.

The initiator should set the DPO bit when the blocks written by this command are not likely to be read in the near future.

The RelAdr (Relative Address) bit must be 0. Relative addressing is not supported. If RelAdr is set to 1, *Check Condition Status* is returned with a Sense Key of *Illegal Request* and additional sense code of *Invalid Field in CDB*.

If the transfer length is 0, the seek occurs, but no data is transferred. Status is returned after the seek completes. This condition is not considered an error.

1.33 Write and Verify

Table 137. Write and Verify Command Descriptor Block								
Byte	BIT							
	7	6	5	4	3	2	1	0
0	Operation Code = 2Eh							
1	LUN			DPO	Reserved = 0		BytChk	RelAdr = 0
2	(MSB) Logical Block Address (LSB)							
3								
4								
5								
6	Reserved = 0							
7	(MSB) Transfer Length (LSB)							
8								
9	VU = 0			Reserved = 0			Flag	Link

The Write and Verify command requests that the Target write the data transferred from the Initiator to the medium and then verify that the data is correctly written. A transfer length of zero indicates that no data is transferred.

The Logical Block Address specifies where the operation is to begin.

A BytChk bit of zero causes the Drive to do an ECC check on the specified range after the write completes successfully. If an ECC check is detected on all re-reads and the data was not corrected (either because it was uncorrectable or the correction was not attempted), a Check Condition status is returned and a Medium Error sense key is built.

A BytChk bit of one causes the Drive to do a byte-by-byte compare of data after it is written to the Drive. The Drive uses the data sent for the write as the compare data, thus there is no extra data-out phase or extra save pointer messages. During the verify step if an ECC check is detected on all re-reads then Check Condition status is returned with Medium Error sense key. If there is no ECC check and a compare error is detected then Check Condition status is returned with a Mismatch sense key. When a compare or medium error occurs, the write may not have completed.

DRP actions for the verify portion of this command are controlled by Mode parameters in 1.6.7, “Page 7h - Error Recovery Parameters for Verify” on page 100. The actual DRP steps are defined in B.1.2, “Verify Commands” on page 275. Normal write command DRP is used for the Write portion of the command. A Mismatch error is not retried.

If caching is enabled, the command performs an implied Force Unit Access (FUA) and an implied Synchronize Cache before starting the operation. This insures that the medium, not the cache, is being verified.

A DPO (Disable Page Out) bit of 1 indicates that the data written by this command is to be assigned the lowest priority for being written into or retained by the cache. A DPO bit of 1 overrides any retention priority specified in the Mode Select Page 8 Caching parameters. A DPO bit of 0 indicates the priority is determined by the

retention priority. See 1.6.8, “Page 8h - Caching Parameters” on page 102 and 4.9, “Segmented Caching” on page 231.

The initiator should set the DPO bit when the blocks written by this command are not likely to be read again in the near future.

The RelAdr (Relative Address) bit must be 0. Relative addressing is not supported. If RelAdr is set to 1, Check Condition Status is returned with a Sense Key of Illegal Request and additional sense code of Invalid Field in CDB.

1.34 Write Buffer

Table 138. Write Buffer Command Descriptor Block								
Byte	BIT							
	7	6	5	4	3	2	1	0
0	Operation Code = 3Bh							
1	LUN			Reserved = 0		Mode		
2	Buffer ID							
3	(MSB)							
4	Buffer Offset							
5								
6	(MSB)							
7	Parameter List Length							
8								
9	VU = 0		Reserved = 0				Flag	Link

The Write Buffer command is used to test the Target buffer and download micro-code to the Target. The values allowed in the Mode field are:

- 000b - Combined Header and Data Mode
- 010b - Write Data
- 100b - Download Microcode
- 101b - Download and Save

If any modes other than shown above are specified, then *Check Condition Status* is returned with a Sense Key of ***Illegal Request*** and additional sense code of ***Invalid Field in CDB***.

- Mode = 000b (Combined Header and Data)

In this mode, the data specified is written to the buffer in sequence.

The Buffer ID must be zero. Receipt of a non-zero Buffer ID results in *Check Condition Status* with Sense Key of ***Illegal Request*** and additional Sense Code of ***Invalid Field in CDB***.

The Buffer Offset must be zero. Receipt of a non-zero Buffer Offset results in *Check Condition Status* with Sense Key of ***Illegal Request*** and additional Sense Code of ***Invalid Field in CDB***.

The four-byte header consists of all reserved bytes. Receipt of a non-zero byte in the header results in *Check Condition Status* with Sense Key of ***Illegal Request*** and additional Sense Code of ***Invalid Field in Parameter List***.

The Parameter List Length includes the length of the header. Therefore, the data written is 4 bytes less than the Parameter List Length. A Parameter List Length of zero indicates no data is transferred. The Parameter List Length must not be greater than the buffer capacity plus four bytes. Receipt of an invalid Parameter List Length results in *Check Condition Status* with Sense Key of a ***Illegal Request*** and additional Sense Code of ***Parameter List Length Error***.

Note: The Buffer Capacity can be determined using Read Buffer mode 000b.

- Mode = 010b (Write Data)

In this mode, the data specified is written to the buffer in sequence starting at the specified offset.

The Buffer ID field must be 0. Receipt of a non-zero Buffer ID results in *Check Condition Status* with Sense Key of ***Illegal Request*** and additional Sense Code of ***Invalid Field in CDB***.

The Buffer Offset field contains the starting byte offset within the data buffer to which the data is transferred. An offset greater than or equal to the buffer capacity results in *Check Condition Status* with Sense key of ***Illegal Request*** and additional Sense Code of ***Invalid Field in CDB***.

The Parameter List Length specifies the number of bytes to transfer. A Parameter List Length of zero indicates no data is transferred. If the sum of the Buffer Offset and the Parameter List Length exceeds the buffer capacity, then the Target returns *Check Condition Status* with Sense Key of ***Illegal Request*** and additional Sense Code of ***Parameter List Length Error***.

Note: The Buffer Capacity can be determined using Read Buffer mode 000b.

- Mode = 100b (Download Microcode) and Mode = 101b (Download and Save)

The microcode is downloaded to the control storage of the Target.

When the mode = 100b (Download Microcode), the downloaded microcode is stored in volatile memory. All code downloaded with this option is lost with the next power cycle.

When the mode = 101b (Download and Save), the downloaded microcode is saved in volatile and non-volatile memory. The original microcode is lost. Non-volatile memory may include the reserved area of the file and electrically programmable memory.

The microcode to be downloaded is supplied to the using system in a single data set whose length is divisible by 8000h. The using system can download the entire microcode with a single Write Buffer command or with multiple Write Buffer commands.

When multiple Write Buffer commands are used, the system must divide the microcode into 8000h byte pieces and sends each piece with consecutive Write Buffer commands. The Buffer ID of the first piece must be set to zero and the Buffer ID must be incremented by one for each subsequent Write Buffer command until the download is complete.

The Buffer ID is used to determine which portion of the microcode is being downloaded. When downloading the entire microcode, the Buffer ID must be zero. When downloading the microcode in pieces, the Buffer ID is zero for the first piece, and the Buffer ID must be incremented by one for each subsequent Write Buffer command until the download is complete. When downloading the microcode, if a value of the Buffer ID is skipped (i.e. the Buffer ID incremented by two or more), the Target returns *Check Condition Status* with Sense Key of ***Illegal Request*** and additional Sense Code of ***Invalid Field in CDB***.

Buffer Offset is ignored.

When the Buffer ID is zero, valid values for the Parameter List Length are zero, 8000h and a Parameter List Length equal to the microcode length. When the Buffer ID is non-zero, the Parameter List Length must be equal to 8000h. Receipt of an invalid Parameter List Length results in *Check Condition Status* with Sense Key of a ***Illegal Request*** and additional Sense Code of ***Parameter***

List Length Error. A Parameter List Length of zero indicates no data is transferred.

Link must be zero when the Buffer ID is the maximum allowed value.

The command may alter the contents of electrical memory depending on the contents of the microcode data set. The Target must be allowed to disconnect before the electrical memory is altered. If the disconnection fails or is not allowed, the Target returns *Check Condition Status* with Sense Key of **Aborted Command** and additional Sense Code of **Message Error**. It is imperative that the Target not be interrupted during this electrical memory altering operation. The Target does not respond to SCSI reset and selection during this operation. The Initiator should take steps to prevent power cycles during execution of this command and should allow for a command timeout for this command as recommended in the product Functional Specification.

The entire microcode is buffered on the media before an attempt is made to alter the electrical memory.

When electrical memory is altered, an internally generated reset occurs as part of the command. The Target generates a Unit Attention condition for all Initiators except the one that issued the Write Buffer command (see 4.1.5, “Unit Attention Condition” on page 202). The Additional Sense Code **Power On Reset**, is reported in the sense data. All queued commands are cleared. Mode Select conditions are restored to their last saved values. The Target preserves Wide Data Transfer and Synchronous Data Transfer agreements only for the Initiator that issued the Write Buffer command.

With Buffer ID is zero and if the Load ID (LID) does not match the LID in the ROM code, the Target returns *Check Condition Status* with Sense Key of **Illegal Request** and additional Sense Code of **Invalid Field in Parameter List**. The Load ID is not checked when the Buffer ID is non-zero.

The downloaded microcode is tested via a checksum. If the checksum fails, the Target returns *Check Condition Status* with Sense Key of **Hardware Error** and additional Sense Code of **Diagnostic Failure**. The microcode is not saved.

On successful completion, the Target generates a Unit Attention condition for all Initiators except the one that issued the Write Buffer command (see 4.1.5, “Unit Attention Condition” on page 202). The Additional Sense Code **Microcode has been changed**, is reported in the sense data.

The first 19 bytes of the microcode data set contain the following:

- Bytes 0 to 2 = Microcode Length
- Bytes 3 to 6 = Load ID
- Bytes 7 and 10 = Modification Level
- Bytes 11 to 14 = PTF Number
- Bytes 15 to 18 = Patch Number

This command will cause the entire cache to be emptied. See 4.9, “Segmented Caching” on page 231.

Note: Idle time functions and other initiators may alter the contents of the buffer. The data read by the Read Buffer command may not match the data written by the Write Buffer mode 000b command. To ensure the buffer is not altered, link the two commands together by setting the Link bit when issuing Write Buffer mode 000b command.

1.35 Write Long

Table 139. Write Long Command Descriptor Block								
Byte	BIT							
	7	6	5	4	3	2	1	0
0	Operation Code = 3Fh							
1	LUN			Reserved = 0				RelAdr = 0
2	(MSB) Logical Block Address (LSB)							
3								
4								
5								
6	Reserved = 0							
7	(MSB) Byte Transfer Length (LSB)							
8								
9	VU = 0		Reserved = 0				Flag	Link

The Write Long command requests that the target write the data transferred by the Initiator to the medium. The data passed during the Write Long command consists of the data bytes followed by the LRC and ECC bytes. The ECC field depends solely on the data and LRC bytes and is unaffected by sync, ID, or VCO fields.

The RelAdr (relative address) bit must be zero. The Drive does not support relative addressing. If RelAdr is set to 1, *Check Condition Status* is returned with a Sense Key of **Illegal Request** and additional sense code of **Invalid Field in CDB** in CDB.

The logical block address field specifies the logical block at which the write operation starts.

The byte transfer length field must specify the number of bytes of data that are returned for the Read Long command. If a non-zero byte transfer length does not exactly match a data length that is returned for the Read Long command, the command terminates with *Check Condition Status*, a sense key set to **Illegal Request**, and an additional sense code set to **Invalid Field in CDB**. The ILI and valid bits are set to one and the information field is set to the difference (residue) of the requested length minus the actual length in bytes. Negative values are indicated by two's complement notation.

The transfer length is calculated as follows:

$$\text{transfer length} = \text{logical blocksize} + (20 * n),$$

where n is the number of physical sectors per LBA.

If the byte transfer length is zero, the seek occurs, but no data is transferred. This condition is not considered an error.

The data for this command is not retained in the cache.

Note: The Drive will attempt a limited amount of error recovery. This consists of a number of command retries, of which the number of retries is internally specified.

1.36 Write Same

Table 140. Write Same Command Descriptor Block							
Byte	BIT						
	7	6	5	4	3	2	1
0	Operation Code = 41h						
1	Logical Unit Number		Reserved = 0		PBdata = 0	LBdata = 0	RelAdr = 0
2	(MSB) Logical Block Address (LSB)						
3							
4							
5							
6	Reserved						
7	Number of Blocks						
8							
9	VU = 0		Reserved = 0			Flag	Link

The Write Same command instructs the Target to write a single block of data, transferred to the Target from the Initiator, to a number of sequential logical blocks.

This command is useful to write large data areas without sending all of the data over the SCSI bus.

The Logical Block Address specifies the address at which the write begins.

The Number of Blocks specifies the number of contiguous blocks to be written. If the number is 0, all of the remaining blocks on the specified Logical Unit are written.

The PBdata (Physical Block Data) option is not supported and must be 0.

The LBdata (Logical Block Data) option is not supported and must be 0.

The RelAdr option is not supported and must be 0.

If RelAdr, PBdata or LBdata is set to 1, *Check Condition Status* is returned with a Sense Key of **Illegal Request** and additional sense code of **Invalid Field in CDB**.

The data for this command is not retained in the cache.

2.0 SCSI Status Byte

A SCSI Status Byte is sent to the Initiator during the Status phase at the termination of each SCSI command unless the command is cleared by an Abort message, any type of Target Reset, or an unexpected Bus Free error condition. The SCSI Status Byte is defined in Table 141.

Byte	BIT							
	7	6	5	4	3	2	1	0
Status	Reserved = 0		Status Code					Rsvd

Status	Bits of Status Code							
	7	6	5	4	3	2	1	0
Good	R	R	0	0	0	0	0	R
Check Condition	R	R	0	0	0	0	1	R
Condition Met	R	R	0	0	0	1	0	R
Busy	R	R	0	0	1	0	0	R
Intermediate/ Good	R	R	0	1	0	0	0	R
Intermediate/ Condition Met	R	R	0	1	0	1	0	R
Reservation Conflict	R	R	0	1	1	0	0	R
Queue Full	R	R	1	0	1	0	0	R
Note: All Reserved fields (R) are set to zero.								

A description of the status represented by each Status Byte is given below:

00h Good status

This status indicates that the Target has successfully completed the SCSI command. For this status, sense is not valid and the Sense key and the Sense code are set to zero.

02h Check Condition status

This status indicates that an error, exception, or abnormal condition has caused sense data to be set. The Initiator should issue a Request Sense command to obtain the sense data and determine the cause of the Check Condition status.

04h Condition Met status

This status indicates that the requested operation is satisfied. (See 1.8, “Pre-Fetch” on page 119) For this status, sense is not valid and the Sense key and the Sense code are set to zero.

08h Busy status

This status indicates that the Drive is busy performing another operation for a different Initiator and is unable to execute the command received from the currently connected Initiator. The Initiator should issue the command again at a later time. Also see 4.1.4, “Command Processing During Execution of

Active I/O Process” on page 200 for a discussion of commands that may return the Busy status. For this status, sense is not valid and the Sense key and the Sense code are set to zero.

10h Intermediate/Good status

This status indicates that the Target has successfully completed a linked command. This status is returned for every command in a series of linked commands (except the last command) unless an error, exception, or abnormal condition causes a Check Condition, Busy, or Reservation Conflict status to be returned. If this status is not returned, the chain of linked commands is broken. For this status, sense is not valid and the Sense key and the Sense code are set to zero.

14h Intermediate/Condition Met

This status is the combination of Condition Met and Intermediate/Good. For this status, sense is not valid and the Sense key and the Sense code are set to zero.

18h Reservation Conflict status

This status indicates that the LUN is reserved (refer to 1.21, “Reserve (6)” on page 141 and 1.18, “Release (6)” on page 137) for a different Initiator and is unable to execute the command received from the currently connected Initiator. The Initiator should issue the command again at a later time. Also see 4.1.10, “Command Processing While Reserved” on page 219 for a discussion of commands that may return the Reservation Conflict status. For this status, sense is not valid and the Sense key and the Sense code are set to zero.

28h Queue Full status

This status indicates that the targets command queue is full. This status is returned when a Queue Tag message is received and there is no room on the command queue for an I/O process from the issuing initiator. See 4.3.2, “Tagged Queuing” on page 222 for more information concerning tagged queuing. For this status, sense is not valid and the Sense key and the Sense code are set to zero.

3.0 SCSI Message System

This chapter details how the message system is implemented on the Drive. Included is a functional description of the supported messages, message timing, message phase error handling and a message state table.

3.1 Supported Messages

The following single-byte messages are supported.

Code	Message	Direction	Negate ATN Before Last ACK
00h	Command Complete	In	N/A
02h	Save Data Pointer	In	N/A
03h	Restore Pointers	In	N/A
04h	Disconnect	In	N/A
05h	Initiator Detected Error	Out	Yes
06h	Abort	Out	Yes
07h	Message Reject	In	N/A
07h	Message Reject	Out	Yes
08h	No Operation	Out	Yes
09h	Message Parity Error	Out	Yes
0Ah	Linked Command Complete	In	N/A
	Linked Command Complete with		
0Bh	Flag	In	N/A
0Ch	Bus Device Reset	Out	Yes
0Dh	Abort Tag	Out	Yes
0Eh	Clear Queue	Out	Yes
12h	Continue I/O Process	Out	Yes
13h	Target Transfer Disable	Out	Yes
80h-FFh	Identify	In	N/A
80h-FFh	Identify	Out	No

In: Target to Initiator. Out: Initiator to target.

The following two-byte messages are supported:

Code	Message	Direction	Negate ATN Before Last ACK
20h	Simple Queue Tag	In	N/A
20h	Simple Queue Tag	Out	No
21h	Head of Queue Tag	Out	No
22h	Ordered Queue Tag	Out	No
23h	Ignore Wide Residue	In	N/A

The following multiple-byte extended messages are supported:

Extended Code	Message	Direction	Negate ATN Before Last ACK
01h	Synchronous Data Transfer Request	In	N/A
01h	Synchronous Data Transfer Request	Out	Yes
03h	Wide Data Transfer Request	In	N/A
03h	Wide Data Transfer Request	Out	Yes

3.1.1 Command Complete (00h)

The Target sends Command Complete message to the Initiator to indicate that the execution of a command (or series of linked commands) has terminated and that valid status has been sent to the Initiator. After successfully sending this message, the Target goes to the bus Free phase. The Target considers the message transmission to be successful when it detects the negation of ACK for the Message In byte with the ATN signal false.

3.1.2 Save Data Pointer (02h)

The Save Data Pointer message is sent from the Target to direct the Initiator to save a copy of the present active data pointer. The value of the current (or active) data pointer should be moved into the corresponding saved data pointer for the currently attached logical unit. The Target sends the Save Data Pointer message to the Initiator prior to sending a Disconnect message to the Initiator if a Data phase has occurred since the physical path was established, and another Data phase is required to successfully complete the command. If the DPSDP bit is set, (see 1.6.2, “Page 0 - Vendor Unique Parameters” on page 75) the Save Data Pointer message will be sent prior to every disconnection once a Data phase has occurred for the current command. If the ASDPE bit (same page) is set, the Save Data Pointer message will precede every Disconnect message regardless of the value of the DPSDP bit. See also 3.1.4, “Disconnect (04h)” on page 169.

3.1.3 Restore Pointers (03h)

The Restore Pointers message is sent from the Target to direct the Initiator to restore the most recently saved pointers (for the currently attached logical unit) to the active state. The saved values for the command, data, and status pointers for the currently attached logical unit should be moved into their corresponding current (or active) pointer. The current command and status pointers should be restored to the beginning of the present command and status areas. The current data pointer should be restored to the beginning of the data area in the absence of a Save Data Pointer message, or to the value at the point at which the last Save Data Pointer message occurred. This message is sent when attempting to retry a Command, Data, or Status phase to recover from a SCSI bus related error (see also 3.6, “SCSI Bus Related Error Handling Protocol” on page 192).

3.1.4 Disconnect (04h)

The Disconnect message is sent from the Target to inform the Initiator that the present physical path is going to be broken. A later reconnect will be required in order to complete the current command. The Target sends the Disconnect message before disconnecting from the SCSI bus. The disconnection is to free the SCSI bus while the Target performs a relatively long operation that does not require the bus. After successfully sending this message to the Initiator, the Target goes to the Bus Free phase. The Target considers the message transmission to be successful when it detects the negation of ACK for the Message In byte with the ATN signal false. The Target only sends this message if the Initiator previously granted the Target the privilege of disconnecting via the Identify message (see 3.1.19, “Identify (80h or C0h)” on page 174).

3.1.5 Initiator Detected Error (05h)

The Initiator Detected Error message is sent from an Initiator to inform the Target that an error has been detected that does not preclude the Target from retrying the previous Command or Status phase. The source of the error either may be related to previous activities on the SCSI bus or may be internal to the Initiator and unrelated to any previous SCSI bus activity.

If the Initiator intends to send this message, the Initiator must assert the ATN signal prior to its release of ACK for the last byte transferred in the Information phase that is to be retried (see also 3.3, “Attention Condition” on page 182). This provides an interlock so the Target can determine which Information phase to retry.

After receiving this message, the Target may retry the previous phase by sending a Restore Pointers message to the Initiator and then repeating the previous Command or Status phase. See also 3.2, “Supported Message Functions” on page 181 and 3.6, “SCSI Bus Related Error Handling Protocol” on page 192.

3.1.6 Abort (06h)

The Abort message specifies that the current I/O process be terminated immediately regardless of its state of execution. Additionally, all other I/O processes from the same initiator on the identified LUN are likewise terminated. Queued I/O processes are deleted from the command queue and active I/O processes are aborted. If the current I/O process is also an active I/O process it will be aborted and the next queued I/O process on the command queue will become an active I/O process. If the logical unit is identified, then all pending data and status for the issuing Initiator and the identified logical unit are cleared and the Target goes to the Bus Free phase. Pending data and status for other initiators and other logical units are not cleared. I/O processes associated with other Initiators are likewise not affected. If a logical unit has not been identified, the Target goes to the Bus Free phase without affecting an operation on any logical unit for the issuing Initiator or any other Initiator. No status or message is sent for any of the I/O processes terminated. It is not an error to send the Abort message to a logical unit that is not currently performing an operation for the Initiator. The target goes to BUS FREE following receipt of this message. Pending sense data is preserved for all initiators.

Note: It is permissible for an Initiator to select the device after the Target has disconnected from the Initiator, for the purpose of sending an Identify message followed by an Abort message. This aborts all I/O processes associated with the issuing Initiator.

3.1.7 Message Reject (07h)

The Message Reject message is sent from either the Initiator or the Target to indicate that the last message received was inappropriate or has not been implemented.

If the Initiator intends to send this message, the Initiator must assert the ATN signal prior to its release of ACK for the REQ/ACK handshake of the message that is to be rejected (see also 3.3, “Attention Condition” on page 182). This provides an interlock so the Target can determine which message is rejected.

If the Target intends to send this message, the Target changes to the Message In phase and sends the Message Reject message to the Initiator prior to transferring any additional message bytes (or any other Information phase bytes) from the Initiator. This implies that the Target may change from the Message Out phase to the Message In phase before all messages are received and ATN is negated. This provides an interlock so the Initiator can determine which message is rejected.

See also 3.2, “Supported Message Functions” on page 181 and 3.6, “SCSI Bus Related Error Handling Protocol” on page 192 for more information on the use of the Message Reject message.

3.1.8 No Operation (08h)

The No Operation message is sent from the Initiator to the Target when the Initiator does not currently have any other valid message to send. See 3.5, “Message State/Action Table” on page 186 for the target's response to this message.

3.1.9 Message Parity Error (09h)

The Message Parity Error message is sent from the Initiator to inform the Target that one or more bytes in the last message it received had a parity error.

If the Initiator intends to send this message, the Initiator must assert the ATN signal prior to its release of ACK for the REQ/ACK handshake of the message that has the parity error. See also 3.3, “Attention Condition” on page 182. This provides an interlock so the Target can determine which message has the parity error.

If the target receives this message under any other circumstance, the Target signals a catastrophic error condition by releasing the BSY signal without any further information transfer attempted.

After receiving this message, the Target may retry sending the previous message to the Initiator (see 3.5, “Message State/Action Table” on page 186, 3.2, “Supported Message Functions” on page 181, and 3.6, “SCSI Bus Related Error Handling Protocol” on page 192).

3.1.10 Linked Command Complete (0Ah)

The Target sends the Linked Command Complete message to the Initiator to indicate that execution of a Linked command (with flag bit equal to zero) has completed and that valid status has been sent to the Initiator. After successfully sending this message, the Target changes to the Command phase to receive the next command.

3.1.11 Linked Command Complete with Flag (0Bh)

The Target sends the Linked Command Complete with Flag message to the Initiator to indicate that execution of a Linked command (with flag bit equal to one) has completed and that valid status has been sent to the Initiator. After successfully sending this message, the Target changes to the Command phase to receive the next command.

3.1.12 Bus Device Reset (0Ch)

The Bus Device Reset message is sent from the Initiator to direct the Target to clear all I/O processes for all initiators. This message forces a hard reset condition which resets the Target to an initial state with no I/O processes pending for any Initiator. A Unit Attention condition is created for all initiators. After receiving this message, the Target goes to the Bus Free phase.

3.1.13 Abort Tag (0Dh)

The Abort Tag message specifies that the current I/O process be terminated immediately regardless of its state of execution. No status or message is sent for the I/O process terminated. I/O processes other than the current I/O process shall not be affected even if they are from the same initiator. If the current I/O process is also an active I/O process then it will be aborted and the next queued I/O process in the command queue will become an active I/O process. If the current I/O process is also a queued I/O process then the queued I/O process will be removed from the command queue and the queue will be adjusted accordingly to preserve the order of execution of the remaining queued I/O processes. It is not an error to establish an I_T_L_Q nexus and send the Abort Tag message to a logical unit that does not currently have an I/O process associated with that I_T_L_Q nexus. The target goes to BUS FREE following receipt of this message. Pending sense data is preserved for all initiators.

Note: It is permissible for an Initiator to select the device after the Target has disconnected from the Initiator, for the purpose of sending an Identify message followed by a Queue Tag message followed by an Abort Tag message. This aborts the tagged I/O process, if any, associated with the established I_T_L_Q nexus.

3.1.14 Clear Queue (0Eh)

The Clear Queue message specifies that all I/O processes from all initiators for the identified LUN be terminated immediately regardless of their state of execution. This message is equivalent to receiving an Abort message from each initiator. All active I/O processes for the identified LUN are aborted, all queued I/O processes for the identified LUN are deleted from the command queue, and the current I/O process is ended by going to BUS FREE. All pending status and data for the identified LUN shall be cleared for all initiators. No status or message is sent for any of the I/O processes terminated. Unit Attention condition will be generated for all other initiators that had I/O processes that were *either active or queued*. The additional sense code will be set to *COMMANDS CLEARED BY ANOTHER INITIATOR*. See 4.1.5, “Unit Attention Condition” on page 202 The target goes to BUS FREE following receipt of a Clear Queue message. Pending sense data is preserved for all initiators.

3.1.15 Continue I/O Process (12h)

The Continue I/O Process message is sent from the initiator to the target to reconnect to an I/O process. This message shall be sent in the same Message Out phase as the Identify message. Thus, if the initiator intends to send the Continue I/O Process message, the Message Out phase following the Selection phase must consist of the Identify, Queue Tag (if any), and Continue I/O Process messages.

The purpose of the Continue I/O Process message is to distinguish a valid initiator reconnection from an incorrect initiator connection.

The initiator may reconnect to an I/O process before the target indicates that it is ready to transfer data (see 3.1.16, “Target Transfer Disable (13h)” for a description of how the target informs the initiator of this condition). In this case, if the target is not ready to continue processing the reconnected I/O process it will attempt to disconnect. If the disconnection attempt is successful and the I/O process is not already active, the target will move the I/O process to the front of the command queue. If the initiator rejects the disconnection or does not grant disconnect privilege in the Identify message, the target will end the connection with a check condition, terminate the I/O process, and generate sense for the initiator/LUN combination. The sense key, code, and qualifier will be set to *ABORTED COMMAND, Message Error*.

It is an error for the initiator to send this message on an initial connection (i.e., there is no I/O process for the nexus) and the target will go to Bus Free phase (see 3.6.1, “Unexpected Bus Free Phase Error Condition” on page 192).

3.1.16 Target Transfer Disable (13h)

The Target Transfer Disable (TTD) message is sent from an initiator to the target to request that subsequent reconnections for data transfer on the I/O process be done by the initiator instead of the target. The target may reconnect for other purposes, but will not enter a data phase on a target reconnection.

This message shall be sent as the last message of the first Message Out phase of an initial connection. The target will continue the I/O process, including any Data Out phases on the initial connection, until the target would normally disconnect, but the target will not reconnect to transfer data. The target will not enter a Data In phase on the initial connection (unless disconnection permission is not granted), and the target will not enter any data phase on any subsequent target reconnection for the I/O process.

When the target is ready to transfer data for a disconnected I/O process for which a TTD message has been sent, the target will reconnect to the initiator for the I/O process (via a Reselection phase, an Identify message, and an optional Queue Tag message), send a Disconnect message, and, if the initiator does not respond with a Message Reject message, go to Bus Free phase. If the initiator rejects the Disconnect message, the target will enter a data phase; otherwise, the initiator may reconnect to the I/O process as described in 3.1.15, “Continue I/O Process (12h)” to do the data transfer.

3.1.17 Queue Tag Messages (20h, 21h, 22h)

Byte	Value	Description
0	20h 21h 22h	Queue Tag message
1	XXh	Queue Tag

Queue Tag messages consist of:

- Simple Queue Tag Message
- Ordered Queue Tag Message
- Head of Queue Tag Message

Queue Tag messages are used to specify an identifier, called a *Queue Tag*, for an I/O process which establishes the I_T_L_Q nexus. The queue tag field is an 8-bit unsigned integer assigned by the initiator during an initial connection. The Queue Tag for every I/O process for each I_T_L nexus must be unique. If the target receives a Queue Tag that is currently in use for the I_T_L nexus it will respond as outlined in 4.1.3, “Incorrect Initiator Connection” on page 199. A Queue Tag becomes available for re-assignment when the I/O process ends.

Whenever an initiator connects to the target, the appropriate Queue Tag message must be sent immediately following the Identify message and within the same MESSAGE OUT phase to establish the I_T_L_Q nexus for the I/O process. Only one I_T_L_Q nexus may be established during a connection. If a Queue Tag message is not sent, then only an I_T_L nexus is established for the I/O process (untagged command).

Whenever the target reconnects to an initiator to continue a tagged I/O process, the Simple Queue Tag message is sent immediately following the Identify and within the same MESSAGE IN phase to revive the I_T_L_Q nexus for the I/O process. Only one I_T_L_Q nexus may be revived during a reconnection. If the Simple Queue Tag message is not sent, then only an I_T_L nexus is revived for the I/O process (untagged command).

3.1.17.1 Simple Queue Tag (20h)

The Simple Queue Tag Message specifies that the current I/O process be placed in the command queue. The order of execution, with respect to other I/O processes received with Simple Queue Tag Messages, is up to the discretion of the target. The target will send a Simple Queue Tag Message after reselection for I/O processes that were received with either Simple, Ordered, or Head of Queue Tag messages.

3.1.17.2 Head of Queue Tag (21h)

The Head of Queue Tag message specifies that the current I/O process be placed first in the command queue. Active I/O processes (if any) will not be preempted by an I/O process received with a Head of Queue Tag. An I/O process received with a Head of Queue Tag will be executed before all other queued I/O processes regardless of the *I_T_L_Q nexus*. Successive I/O processes received with Head of Queue Tag messages will be executed in LIFO order.

3.1.17.3 Ordered Queue Tag (22h)

The Ordered Queue Tag Message specifies that the current I/O process be placed in the command queue for execution in the order received. All queued I/O processes for the logical unit received prior to the current I/O process are executed before the current I/O process is executed. All queued I/O processes received after the current I/O process are executed after the current I/O process is executed, except for I/O processes received with a HEAD OF QUEUE tag message.

Note: In multi-initiator environments where both Tagged and Untagged I/O processes are present together in the command queue, untagged I/O processes are treated as though they were received with a Simple Queue tag for purposes of execution scheduling.

3.1.18 Ignore Wide Residue (23h)

Byte	BIT							
	7	6	5	4	3	2	1	0
0	Message Code = 23h							
1	Ignore = 01h							

The Ignore Wide Residue Message is sent from the target to indicate that the number of valid bytes sent during the last REQ/ACK handshake of a DATA IN phase is less than the negotiated transfer width. The ignore field (always = 01h) indicates that one byte (data bits 8-15) should be ignored. This message is sent immediately following the DATA IN phase and prior to any other messages. Even though a byte is invalid, its corresponding parity bit is valid for the value transferred.

3.1.19 Identify (80h or C0h)

The Identify message is sent by either the Initiator or the Target to establish the physical path connection between the Initiator and the Target for a particular logical unit.

The Identify message is defined as follows:

- Bit 7** This bit is always set to one to distinguish the Identify message from other messages.
- Bit 6** This bit is only set to one by the Initiator to grant the Target the privilege of disconnecting. If this bit is 0, the Target does not disconnect. This bit is set to 0 when the Target sends an Identify message to the Initiator during reconnection.
- Bit 5** This bit is reserved and must be zero for an Identify message.
- Bits 4-0** These bits specify the LUN. A value other than zero identifies an invalid LUN. For a description of the response to an invalid LUN see 4.1.2, "Invalid LUN Processing" on page 198.

If an Identify message is received with bit 5 not equal to zero, the Target responds with the Message Reject message and goes to the Bus Free phase to signal a catastrophic error condition (see 3.5, "Message State/Action Table" on page 186).

Only one LUN may be identified for any one selection sequence. If the Target receives an Identify message with a new logical unit number after the LUN has previously been identified, the Target goes to the Bus Free phase to signal a catastrophic error. The Initiator may send more than one Identify message during a selection sequence in order to toggle disconnect/reconnect permission if the specified LUN remains the same. (see 3.2, “Supported Message Functions” on page 181).

When the Identify message is sent from the Target to the Initiator during reconnection, an implied Restore Pointers message must be performed by the Initiator.

3.1.20 Extended Messages (01h,xxh)

A value of one in the first byte of a message indicates the beginning of a multiple-byte extended message. The minimum number of bytes sent for an extended message is three. The extended message format is shown below.

Byte	Value	Description
0	01h	Extended message
1	n	Extended message length
2	y	Extended message code
3 - (n+1)	x	Extended message arguments

The extended message length specifies the length in bytes of the extended message code plus the extended message arguments to follow. The total length of the message is equal to the extended message length plus two. A value of zero for the extended message length indicates 256 bytes to follow.

The Drive supports two extended messages; Synchronous Data Transfer Request (01h,01h) and Wide Data Transfer Request (01h,03h). The only extended message lengths supported by the Target are 02h and 03h. If an unsupported message code or message length is received, the Target goes to MESSAGE IN phase immediately after the byte in error and sends a Message Reject message to the Initiator.

If attention is negated before all bytes of a multiple-byte extended message are received, the file will go to BUS FREE to signal a catastrophic error.

3.1.21 Synchronous Data Transfer Request (01h,01h)

A pair of Synchronous Data Transfer Request messages are exchanged between an Initiator and a Target to establish the synchronous data transfer mode between the two devices. The message exchange establishes the permissible transfer period and REQ/ACK offset for a synchronous data transfer between the two devices. The Initiator may initiate a synchronous data transfer negotiation at any time after the LUN has been identified. The Target initiates a synchronous transfer negotiation if the Target has not negotiated with the Initiator since the last time the Target was Reset (Power-on Reset, SCSI Bus “hard” Reset, Bus Device Reset message, or Self Initiated Reset).

Target-initiated synchronous negotiation normally occurs immediately following the wide data transfer negotiation. If a data transfer width agreement exists, the target-initiated synchronous negotiation occurs either immediately following the Command phase or immediately following the first reconnection.

The implied synchronous agreement remains in effect until the Target is Reset (Power-on Reset, SCSI Bus “hard” Reset, Bus Device Reset message, or Self Initiated Reset), a new synchronous agreement is negotiated, or the Target receives a Wide Data Transfer Request message. If a Reset occurs, the Target goes to asynchronous mode.

3.1.21.1 Synchronous Data Transfer Request Message Definition

Byte	Value	Description
0	01h	Extended message
1	03h	Extended message length
2	01h	Synchronous Data Transfer Request code
3	M	Transfer period (M times 4 nanoseconds)
4	X	REQ/ACK offset.

The transfer period (M above) is the minimum time between leading edges of successive REQ pulses and of successive ACK pulse to meet the device requirements for successful reception of data while using synchronous data transfers. The Drive supports transfer periods in the range 100 nSec to 450 nSec in 25 nSec increments. The Target will use the "fast SCSI data transfer" timings if a synchronous agreement results in a target transfer period of less than 200 nSec.

The REQ/ACK offset (X above) is the maximum number of REQ pulses that can be outstanding before its corresponding ACK pulse is received at the Target. A REQ/ACK offset value of zero indicates asynchronous mode. The Drive supports REQ/ACK offset values in the range 0 through 15 for 16 bit data transfers and offset values in the range 0 through 30 for 8 bit data transfers.

3.1.21.2 Synchronous Negotiation Started by the Initiator

If the Initiator recognizes that negotiation is required and sends a Synchronous Data Transfer Request message out, the Target responds by changing to the Message In phase and sending a Synchronous Data Transfer Request message in to the Initiator prior to transferring any additional message bytes (or any other Information phase bytes) from the Initiator. This provides an interlock during the synchronous negotiation.

The Drive responds to each Initiator requested transfer period as shown in the following table:

Initiator Request	Target Response	Target Transfer Period	Maximum Burst Rate
$0 \leq Mi \leq 25$	Mt = 25	100 nSec	10.00 MT/s
$26 \leq Mi \leq 31$	Mt = Mi	125 nSec	8.00 MT/s
$32 \leq Mi \leq 37$	Mt = Mi	150 nSec	6.67 MT/s
$38 \leq Mi \leq 43$	Mt = Mi	175 nSec	5.71 MT/s
$44 \leq Mi \leq 50$	Mt = Mi	200 nSec	5.00 MT/s
$51 \leq Mi \leq 56$	Mt = Mi	225 nSec	4.44 MT/s
$57 \leq Mi \leq 62$	Mt = Mi	250 nSec	4.00 MT/s
$63 \leq Mi \leq 68$	Mt = Mi	275 nSec	3.64 MT/s

Table 150 (Page 2 of 2). Initiator Request/Target Response			
Initiator Request	Target Response	Target Transfer Period	Maximum Burst Rate
69 <= Mi <= 75	Mt = Mi	300 nSec	3.33 MT/s
76 <= Mi <= 81	Mt = Mi	325 nSec	3.08 MT/s
82 <= Mi <= 87	Mt = Mi	350 nSec	2.86 MT/s
88 <= Mi <= 93	Mt = Mi	375 nSec	2.67 MT/s
94 <= Mi <= 100	Mt = Mi	400 nSec	2.50 MT/s
101 <= Mi <= 106	Mt = Mi	425 nSec	2.35 MT/s
107 <= Mi <= 112	Mt = Mi	450 nSec	2.22 MT/s
113 <= Mi <= 255	Mt = Mi	(Asynchronous mode)	N/A

Note: MT/s means Mega-Transfers per second. If the established data transfer width is 8 bits, the MB/s rate is the same as the MT/s rate. If the established data transfer width is 16 bits, the MB/s is two times the MT/s rate. For example, 10.00 MT/s on a 16 bit transfer width is an effective transfer rate of 20.00 MB/s.

The Drive responds to each Initiator requested REQ/ACK offset as follows:

If the Initiator requests a transfer period that is greater than 448 nSec ($M > 112$), the Target will respond with the same period that the initiator requested but with a REQ/ACK offset of 0.

If the Initiator requests a transfer period in the acceptable range and requests a REQ/ACK offset value that is greater than 15 with an established 16 bit transfer width or greater than 30 with an established 8 bit transfer width, the Target responds with a REQ/ACK offset value of 15 or 30 respectively.

If the Initiator requests a transfer period and an offset value in the acceptable range, the response is equal to the Initiator's requested value.

Note: If the REQ/ACK offset value is 0, this indicates asynchronous mode.

If following the Target's response above the Initiator asserts the ATN signal and the first message received is either a Message Parity Error or a Message Reject message, the Target negates the synchronous agreement and goes to asynchronous mode. For the Message Parity Error case, the implied synchronous agreement is reinstated if the Target successfully retransmits the Synchronous Data Transfer Request message to the Initiator (see 3.6.3, "Message In Phase Retry" on page 194). For any other message, the Target completes negotiation and goes to synchronous mode.

3.1.21.3 Synchronous Negotiation Started by the Target

If the Target recognizes that negotiation is required, the Target sends a Synchronous Data Transfer Request message to the Initiator with the transfer period equal to 100 nSec ($M = 25$) and the REQ/ACK offset equal to 15 ($X = 15$) for an established 16 bit transfer width or 30 ($X = 30$) for an established 8 bit transfer width. The Initiator must respond by asserting the ATN signal prior to its release of ACK for the REQ/ACK handshake of the last byte of the Synchronous Data Transfer Request message. (see 3.3, "Attention Condition" on page 182). This provides an interlock during the synchronous negotiation. If the Initiator does not assert the ATN signal, the Target goes to asynchronous mode. If the Initiator does assert the ATN signal,

the Target changes to the Message Out phase and receives a message from the Initiator.

If the first message received is a Synchronous Data Transfer Request message, the Target establishes the new data transfer mode. The Drive interprets the Initiator corresponding transfer period as shown in the following table:

Initiator's Response	Target Transfer Period	Maximum Burst Rate
$0 <= Mi <= 24$	Send Message Reject (Asynchronous mode)	N/A
$25 <= Mi <= 25$	100 nSec	10.00 MT/s
$26 <= Mi <= 31$	125 nSec	8.00 MT/s
$32 <= Mi <= 37$	150 nSec	6.67 MT/s
$38 <= Mi <= 43$	175 nSec	5.71 MT/s
$44 <= Mi <= 50$	200 nSec	5.00 MT/s
$51 <= Mi <= 56$	225 nSec	4.44 MT/s
$57 <= Mi <= 62$	250 nSec	4.00 MT/s
$63 <= Mi <= 68$	275 nSec	3.64 MT/s
$69 <= Mi <= 75$	300 nSec	3.33 MT/s
$76 <= Mi <= 81$	325 nSec	3.08 MT/s
$82 <= Mi <= 87$	350 nSec	2.86 MT/s
$88 <= Mi <= 93$	375 nSec	2.67 MT/s
$94 <= Mi <= 100$	400 nSec	2.50 MT/s
$101 <= Mi <= 106$	425 nSec	2.35 MT/s
$107 <= Mi <= 112$	450 nSec	2.22 MT/s
$113 <= Mi <= 255$	Send Message Reject (Asynchronous mode)	N/A

Note: If the corresponding transfer period received from the Initiator indicates a transfer period that is less than 100 nSec ($M < 25$) or greater than 448 nSec ($M > 112$), the Target sends a Message Reject message to the Initiator to indicate asynchronous mode.

The Drive interprets each Initiator requested REQ/ACK offset as follows:

- If the Initiator requests a REQ/ACK offset value that is greater than 15 with an established 16 bit data transfer width or 30 with an established 8 bit data transfer width, the Target changes to the Message In phase, sends a Message Reject message to the Initiator, and goes to asynchronous mode.
- If the value is 0, the Target goes to asynchronous mode. For all other values, the Target interprets the REQ/ACK offset to be equal to the Initiator requested value.

If the first message received from the Initiator is either a Message Parity Error or a Message Reject message, the Target goes to asynchronous mode. For the Message Parity Error case, the synchronous negotiation is restarted if the Target successfully retransmits the Synchronous Data Transfer Request message to the Initiator. (see 3.6.3, “Message In Phase Retry” on page 194).

If the first message received from the Initiator is any other message, the Target goes to asynchronous mode. The Target assumes that the Initiator does not support synchronous mode and does not attempt to renegotiate with this Initiator. (see 3.5,

“Message State/Action Table” on page 186 for more information regarding the Target's response to each message received from the Initiator during synchronous negotiation).

The implied agreement for synchronous operation is not considered to exist by the Target until the Target leaves the Message Out phase, implying that no parity error was detected. If the Target detects a parity error while attempting to receive the message from the Initiator, the Target goes to asynchronous mode. The Target will attempt to resume synchronous negotiation by retrying the Message Out phase (see also 3.6.2, “Message Out Phase Retry” on page 193).

Note: If during the Message In phase of negotiations, either Target or Initiator started, ATN is asserted prior to transmission of the last byte of the message and the message is not Message Parity or Message Reject, the Target goes to asynchronous mode. Message Reject and Message Parity Errors are handled as described in 3.1.21.2, “Synchronous Negotiation Started by the Initiator” on page 176 and 3.1.21.3, “Synchronous Negotiation Started by the Target” on page 177.

Note: Target initiated synchronous negotiation is selectable via the DSN bit. See 1.6.2, “Page 0 - Vendor Unique Parameters” on page 75 for more information.

3.1.22 Wide Data Transfer Request (01h,03h)

A pair of Wide Data Transfer Request messages are exchanged between an Initiator and a Target to establish a data transfer width agreement between the two devices. The Initiator may initiate a wide data transfer negotiation at any time after the LUN has been identified. The Target initiates a wide data transfer negotiation if the Target has not negotiated with the Initiator since the last time the Target was Reset (Power-on Reset, SCSI Bus “hard” Reset, Bus Device Reset message, or Self Initiated Reset).

Target-initiated negotiation occurs either immediately following the Command phase or immediately following the first reconnection. The Target will negotiate the data transfer width agreement prior to negotiating the synchronous data transfer agreement. If a synchronous data transfer agreement is in effect when a Wide Data Transfer Request message is received, the Target will reset the synchronous agreement to asynchronous mode.

The implied data transfer width agreement remains in effect until the Target is Reset (Power-on Reset, SCSI Bus “hard” Reset, Bus Device Reset message, or Self Initiated Reset) or a new data transfer width agreement is negotiated. If a Reset occurs, the Target goes to eight bit mode.

3.1.22.1 Wide Data Transfer Request Message Definition

Byte	Value	Description
0	01h	Extended message
1	02h	Extended message length
2	03h	Wide Data Transfer Request code
3	E	Transfer Width Exponent

The data transfer width is two to the transfer width exponent bytes wide. Valid data transfer widths are 8 bits (E = 00h) and 16 bits (E = 01h). Value of E greater than 01h are reserved.

3.1.22.2 Transfer Width Negotiation Started by the Initiator

If the Initiator recognizes that negotiation is required and sends a Wide Data Transfer Request message out, the Target responds by changing to the Message In phase and sending a Wide Data Transfer Request message in to the Initiator prior to transferring any additional message bytes (or any other Information phase bytes) from the Initiator. This provides an interlock during the data transfer width negotiation.

The Drive responds to each Initiator requested transfer width exponent as shown in the following table:

Table 153. Initiator Request/Target Response		
Initiator Request	Target Response	Target Data Transfer Width
E _i = 0	E _t = 0	8 Bit Data Transfers
E _i > 0	E _t = 1	16 Bit Data Transfers

If following the Target's response above the Initiator asserts the ATN signal and the first message received is either a Message Parity Error or a Message Reject message, the Target negates the data transfer width agreement and goes to 8 bit mode. For the Message Parity Error case, the implied data transfer width agreement is reinstated if the Target successfully retransmits the Wide Data Transfer Request message to the Initiator (see 3.6.3, "Message In Phase Retry" on page 194). For any other message, the Target completes negotiation and goes to the negotiated data transfer width.

3.1.22.3 Transfer Width Negotiation Started by the Target

If the Target recognizes that negotiation is required, the Target sends a Wide Data Transfer Request message to the Initiator with the transfer width exponent equal to 1 (E = 1). The Initiator must respond by asserting the ATN signal prior to its release of ACK for the REQ/ACK handshake of the last byte of the Wide Data Transfer Request message. (see 3.3, "Attention Condition" on page 182). This provides an interlock during the wide data transfer negotiation. If the Initiator does not assert the ATN signal, the Target goes to 8 bit mode. If the Initiator does assert the ATN signal, the Target changes to the Message Out phase and receives a message from the Initiator.

If the first message received is a Wide Data Transfer Request message, the Target establishes the new data transfer mode. The Drive interprets the Initiator corresponding transfer width exponent as shown in the following table:

Table 154. Target Response to Initiator's Transfer Period	
Initiator's Response	Target Data Transfer Width
$E_i = 0$	8 Bit Data Transfers
$E_i = 1$	16 Bit Data Transfers
$E_i > 1$	Send Message Reject (8 Bit Data Transfers)

Note: If the corresponding transfer width exponent received from the Initiator indicates a data transfer width that is greater than 16 bits ($E > 1$) the Target sends a Message Reject message to the Initiator to indicate 8 bit data transfer mode.

If the first message received from the Initiator is either a Message Parity Error or a Message Reject message, the Target goes to 8 bit data transfer mode. For the Message Parity Error case, the wide data transfer negotiation is restarted if the Target successfully retransmits the Wide Data Transfer Request message to the Initiator. (see 3.6.3, “Message In Phase Retry” on page 194).

If the first message received from the Initiator is any other message, the Target goes to 8 bit data transfer mode. The Target assumes that the Initiator does not support wide data transfers and does not attempt to renegotiate with this Initiator. (see 3.5, “Message State/Action Table” on page 186 for more information regarding the Target's response to each message received from the Initiator during wide data transfer negotiation).

The implied agreement for wide data transfer operation is not considered to exist by the Target until the Target leaves the Message Out phase, implying that no parity error was detected. If the Target detects a parity error while attempting to receive the message from the Initiator, the Target goes to 8 bit data transfer mode. The Target will attempt to resume the wide data transfer negotiation by retrying the Message Out phase (see also 3.6.2, “Message Out Phase Retry” on page 193).

Note: If during the Message In phase of negotiations, either Target or Initiator started, ATN is asserted prior to transmission of the last byte of the message and the message is not Message Parity or Message Reject, the Target goes to 8 bit data transfer mode. Message Reject and Message Parity Errors are handled as described in 3.1.22.2, “Transfer Width Negotiation Started by the Initiator” on page 180 and 3.1.22.3, “Transfer Width Negotiation Started by the Target” on page 180.

Note: Target initiated negotiation of wide transfers is selectable by the DSN bit. See 1.6.2, “Page 0 - Vendor Unique Parameters” on page 75 for more information.

3.2 Supported Message Functions

The implementation of the supported messages also includes the following functions:

- Retry SCSI Command or Status phase

The retry is caused by one of the following error conditions:

- Target detected SCSI bus parity error (Command phase)

- Target receives Initiator Detected Error message during or at the conclusion of an information transfer phase (Command or Status phase)

Note: The Initiator may send the Initiator Detected Error message as a result of an Initiator detected SCSI bus parity error or an internal error.

- Retry Message Out phase

The retry is caused by a Target detected SCSI bus parity error during the Message Out phase.

- Retry Message In phase

The retry is caused by the receipt of a Message Parity Error message immediately following a Message In phase.

Note: The Initiator may send the Message Parity Error message as a result of an Initiator detected SCSI bus parity error during the Message In phase.

- Receipt of multiple Identify messages

The Initiator is allowed to send multiple Identify messages out in order to toggle the disconnect/reconnect permission bit (bit 6). This may be used to selectively enable or disable disconnect/reconnect permission during portions of a command.

- Message Reject during Target disconnection

If the Initiator rejects the Save Data Pointer message, the Target disables disconnect/reconnect permission. This is equivalent to receiving an Identify message with bit 6 (disconnect/reconnect permission bit) equal to zero. This causes the Target to inhibit the pending disconnection. If the Initiator rejects the Disconnect message, the Target does not disconnect but may attempt to disconnect at a later time. This function may be used to selectively disable disconnection during portions of a command.

3.3 Attention Condition

The Attention Condition allows an Initiator to inform the Target that a Message Out phase is desired. The Initiator may create the Attention Condition by asserting the ATN signal at any time except during the Arbitration phase or Bus Free phase.

The Initiator must create the Attention Condition by asserting the ATN signal before releasing ACK for the last byte transferred in a bus phase to guarantee that the Attention Condition is honored before transition to a new bus phase. This guarantees a predictable Target response to messages received during the Message Out phase for this Attention Condition. If the ATN signal is asserted later, it may be honored in the current bus phase or the next bus phase and then may not result in the expected action or may result in a Bus Free condition. See Figure 1 on page 183 and Figure 2 on page 184 for an example of the desired time to assert ATN during an information transfer phase.

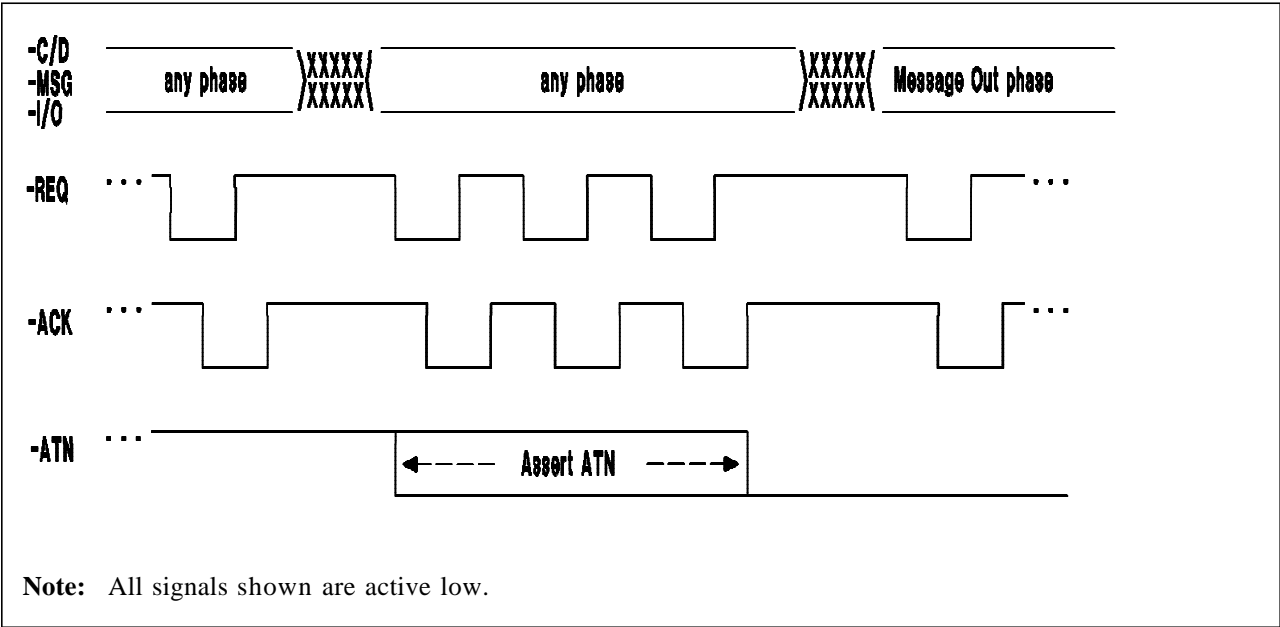

Figure 1. Attention Condition during Asynchronous Information Transfer phase

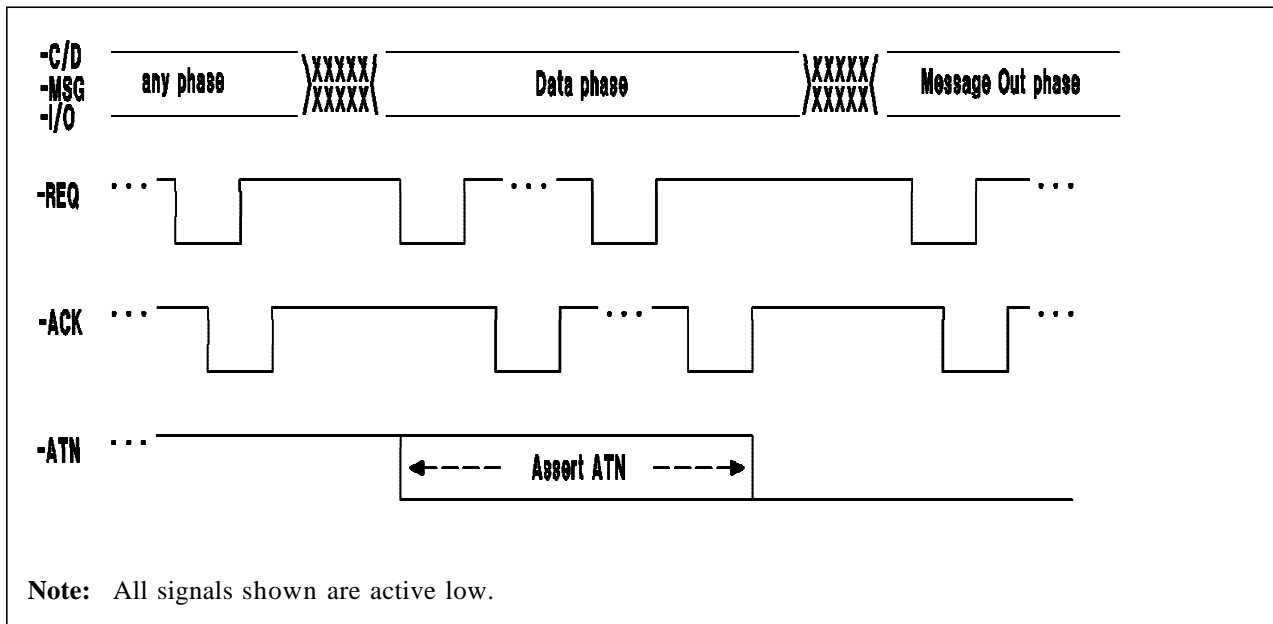

Figure 2. Attention Condition during Synchronous Data Transfer phase

After the Initiator asserts the ATN signal, the Target responds with the Message Out phase as follows:

- If ATN occurs during a Command phase, the Message Out phase occurs after part or all of the Command Descriptor Block has been transferred to the Target. The Initiator must continue REQ/ACK handshakes during the Command phase until the Target enters the Message Out phase.
- If ATN occurs during a Data In or Data Out phase, the Message Out phase occurs after part or all of the data bytes have been transferred and not necessarily on a logical block boundary. The Initiator must continue REQ/ACK handshakes (asynchronous transfer) or ACK pulses to reach an offset of zero (synchronous transfer) until the Target enters the Message Out phase.

Note: The Drive SCSI hardware and microcode implementation restricts the Target response to the Attention Condition during a parameter or sense data phase as follows: The Target detects the Attention Condition within 256 bytes after the assertion of the ATN. During a data out phase that is not for parameter data, the target detects the Attention Condition within 2 bytes. During a data in phase that is not for parameter or sense data, the target detects the Attention Condition within 34 bytes. Once the Target detects the Attention Condition, it will wait until all outstanding SCSI ACK pulses have been received before entering the Message Out phase. Any data that is received after attention is asserted will not be written to the disk.

- If ATN occurs during a Status phase, the Message Out phase occurs after the REQ/ACK handshake of the status byte has been completed.
- If ATN occurs during a Message In phase, the target shall enter Message Out phase before it sends another message. This permits a Message Parity Error message from the initiator to be associated with the appropriate message.
- If ATN occurs during a Selection phase and before the Initiator releases the BSY signal, the Message Out phase occurs following the completion of the Selection phase.

- If ATN occurs during a Reselection phase, the Target temporarily ignores the Attention condition and completes the reselection phase and Message In phase to send an Identify message. The Message Out phase occurs after the Target has sent the Identify message to the Initiator. This is indistinguishable from an Attention Condition during the Identify Message In phase.

The Initiator must keep the ATN signal asserted if more than one message byte is to be transferred during the Message Out phase. The Target processes each message byte (multiple-bytes for an extended message) prior to receiving the next message from the Initiator. The Target continues to handshake and process byte(s) in the Message Out phase until ATN goes false, unless one of the following conditions occurs:

- The Target receives an illegal or inappropriate message and goes to the Message In phase to send a Message Reject message.
- The Target detects a catastrophic error condition and goes to the Bus Free phase.

Note: If the Target detects a parity error during the Message Out phase, the Target continues to handshake byte(s) in this phase until ATN goes false. The Target does not process any messages received after the parity error is detected. (see 3.6.2, “Message Out Phase Retry” on page 193).

The Initiator must negate the ATN signal while REQ is true and ACK is false during the last REQ/ACK handshake of the Message Out phase to ensure a predictable Target response. If ATN is negated later, the Target may or may not request an additional Message Out byte. If ATN is negated earlier during a multiple-byte Message Out phase, the Target may or may not request additional Message Out byte(s). If ATN is negated prior to the Target entering the Message Out phase, the Target may or may not enter the Message Out phase.

3.4 SCSI Bus Parity Error Detection

SCSI bus parity errors may be detected by either the Initiator or the Target. The Initiator detects parity errors during the Data In, Status, or Message In phases. If a retry is desired to attempt to recover from one of these parity errors, the Initiator must assert the ATN signal to create an Attention Condition and send either the Initiator Detected Error message (Data In or Status phase) or Message Parity Error message (Message In phase) to the Target. The ATN signal must be asserted within the phase during which the parity error was detected to guarantee proper Target response. See 3.3, “Attention Condition” on page 182 for a description of the proper time to assert the ATN signal and the Target's response to the Attention Condition. See 3.6.7, “Data In Phase Retry” on page 195, 3.6.5, “Status Phase Retry” on page 195, and 3.6.3, “Message In Phase Retry” on page 194 for a description of the retry of each of these phases.

The Target detects parity errors during the Command, Data Out, or Message Out phases. After the parity error is detected, the Target may attempt to retry the phase. The Target parity error detection for each of these phases is defined as follows:

- If a parity error occurs during a Command phase, the retry occurs after part or all of the Command Descriptor Block has been transferred to the Target. The Initiator must continue REQ/ACK handshakes during the Command phase until the Target attempts the retry. See 3.6.4, “Command Phase Retry” on page 194 for a description of the retry of this phase.

- If a parity error occurs during a Data Out phase, the Target responds to the parity error after part or all of the data bytes have been transferred and not necessarily on a logical block boundary. The Initiator must continue REQ/ACK handshakes (asynchronous transfer) or ACK pulses to reach an offset of zero (synchronous transfer) until the Target terminates the Data phase. There is no guarantee that the medium will or will not be altered with the data received prior to the parity error.

Note: The Target detects the parity error immediately. The byte with the parity error and any data received after that byte will not be written to the disk.

- If a parity error occurs during a Message Out phase, the retry occurs after all remaining Message Out bytes have been received from the Initiator (indicated by ATN false). The Target does not process any messages received after the parity error is detected. The Initiator must continue REQ/ACK handshakes during the Message Out phase until ATN is false and the Target attempts the retry. See 3.6.2, “Message Out Phase Retry” on page 193 for a description of the retry of this phase.

3.5 Message State/Action Table

This section describes the Target's action or response to inputs that affect the SCSI message systems during various stages of command execution. The description is in the form of a state/action table, that describes the Target's Action in response to various inputs during command execution states.

The inputs are factors that influence the SCSI Message System. The inputs include:

- Messages received from the Initiator in response to an Attention Condition
- Target detected SCSI bus parity errors

The state represents the current SCSI bus phase interrupted by the input. In addition, some state/input combinations are divided into two States to represent either the first or second error to be retried during this SCSI bus connection.

The Action shows the Target's response to the Input that interrupted the present State. The Action also includes the Target's Next State in response to the input.

The Next State may be examined to show the Target's Action in response to the next input. This process may then be repeated to show the series of Target actions in response to a series of messages (or input) received from the Initiator. The initial State of the Target (prior to the assertion of ATN) and the succeeding actions (internal indicators set by actions) determines how the Target proceeds (for example, continue previous information phase, retry previous information phase, start disconnection, send Check Condition status, and so on).

The entries in the Message State/Action Table should be interpreted as shown below:

Table 155. Action Table Example	
SCSI Phase or State Interrupted	<i>Present SCSI State</i>
SCSI State Number	<i>State Number</i>
<i>Input 1</i>	<i>ACTION 1 ACTION 2 (NEXT STATE)</i>
<i>Input 2</i>	<i>ACTION 1A ACTION 2A (NEXT STATE)</i>
	<i>ACTION 1B ACTION 2B (NEXT STATE)</i>

- ACTION 1 & ACTION 2 are both done in response to Input 1.
- ACTION 1A & ACTION 2A are both done in response to Input 2 if this is the first error for this connection.
- ACTION 1B & ACTION 2B are both done in response to Input 2 if this is the second error for this connection.

The following Message Action Legend defines the meaning of each Target Action entry in the Message State/Action Table.

compact.

Table 156. Message Action Legend		
AT	=	Return to Asynchronous Transfer mode
BF	=	Go to Bus Free phase
CC	=	Send Command Complete message
CD	=	Clear internal indication of disconnect/reconnect permission
CHK	=	Send Check Condition status
CS	=	Clear Sense for the Initiator
DATA	=	Go to Data Phase
DATA1	=	Go to Data Phase if a TTD message was received for this process, otherwise SS and BF. If data transfer is not ready, DM and BF.
DM	=	Send Disconnect message
DW	=	Return to default Wide Data Transfer mode (8 bit)
ET	=	Establish Synchronous Transfer mode
EW	=	Establish Wide Data Transfer mode
ID	=	Send Identify message
IW	=	Send Ignore Wide Residue message
LCC	=	Send Linked Command Complete message
MR	=	Send Message Reject message
MR1	=	Message reject issued for nonzero reserved bits but not for a different LUN
na	=	not applicable
ND	=	Set internal indication to suspend pending disconnection
NP	=	Continue to the next SCSI phase
PS	=	Preserve Sense Data for all Initiators
RMO	=	Flush Message Out bytes until ATN=0 and retry Message Out phase
RP	=	Send Restore Pointers message
RST	=	Perform Hard Reset
SDP	=	Send Save Data Pointer message
SM	=	Send Synchronous Data Transfer Request message
SQ	=	Send Simple Queue Tag message
SS	=	Abort command execution for Identified Initiator/LUN and set appropriate sense data if the LUN is valid
SS1	=	Same as SS unless error on message immediately following ID message and Tagged Queuing is enabled. In this case PS
SVD	=	Save internal indication of disconnect/reconnect permission
SVL	=	Save LUN second LUN different from the first
SVQ	=	Establish ITLQ Nexus and Save TAG if immediately after ID MSG, else message reject
SVT	=	Set internal indication that a TTD message was received for this process
SW	=	Send Wide Data Transfer Request message

Table 157. Message State/Action Table (Part 1)

SCSI Phase or State Interrupted	Selection Phase (LUN not Identified)	Identify Message Out (after Selection)	Queue Tag Message Out (after ID Message)	Command Phase	Message In Restore Pointers (03h) for Command Phase	Message In Save Data Pointer (02h)	Message In Disconnect (04h)	Message In Identify (8Xh)	Message In Simple Queue Tag (20h)
	1	2	3	4	5	6	7	8	9
SCSI State Number									
Valid Identify (80H-87H, C0H-C7H)	SVL SVD (2)	SVD (25)	SVD (25)	SVD (25)	SVD (25)	SVD (25)	SVD (25)	SVD (25)	SVD (25)
Invalid Identify with Reserved Bits = 1	SS CHK	SS CHK	SS CHK	SS CHK	SS CHK	SS CHK	SS CHK	SS CHK	SS CHK
Invalid Identify with Different LUN	na	SS BF	SS BF	SS BF	SS BF	SS BF	SS BF	SS BF	SS BF
Queue Tag Message (20h, 21h, 22h)	PS BF	SVQ	MR (23)	MR (23)	MR (23)	MR (23)	MR (23)	MR (23)	MR (23)
Target Transfer Disable Message (13h)	PS BF	SVT (4)	SVT (4)	MR (23)	MR (23)	MR (23)	MR (23)	MR (23)	MR (23)
Continue I/O Process Message (12h)	PS BF	DATA1 (14-17)	DATA1 (14-17)	MR (23)	MR (23)	MR (23)	MR (23)	MR (23)	MR (23)
Sync Data Transfer Request (01h,01h) with Acceptable Transfer Mode	PS BF	SM ET (10)	SM ET (10)	SM ET (10)	SM ET (10)	SM ET (10)	SM ET (10)	SM ET (10)	SM ET (10)
Sync Data Transfer Request (01h,01h) with Unacceptable Transfer Mode	PS BF	AT SM (10)	AT SM (10)	AT SM (10)	AT SM (10)	AT SM (10)	AT SM (10)	AT SM (10)	AT SM (10)
Wide Data Transfer Request (01h,03h)	PS BF	AT EW SW (12)	AT EW SW (12)	AT EW SW (12)	AT EW SW (12)	AT EW SW (12)	AT EW SW (12)	AT EW SW (12)	AT EW SW (12)
Initiator Detected Error (05H)	PS BF	SS CHK (19)	SS CHK (19)	RP (5) SS CHK (19)	SS CHK (19)	SS CHK (19)	SS CHK (19)	SS CHK (19)	SS CHK (19)
Abort (06H)	PS BF	PS BF	PS BF	PS BF	PS BF	PS BF	PS BF	PS BF	PS BF
Message Reject (07H)	PS BF	MR (23)	MR (23)	MR (23)	SS CHK (19)	ND CD NP	ND NP	ID (8) SS BF	SQ (9) SS BF
No Operation (NOP) (08H)	PS BF	NP	NP	NP	NP	NP	NP	NP	NP
Message Parity Error (09H)	PS BF	SS BF	SS BF	SS BF	SS BF	SDP (6) SS BF	DM (7) SS BF	ID (8) SS BF	QT (9) SS BF
Bus Device Reset (0CH)	RST BF	RST BF	RST BF	RST BF	RST BF	RST BF	RST BF	RST BF	RST BF
Abort Tag Message (0Dh)	PS BF	PS BF	PS BF	PS BF	PS BF	PS BF	PS BF	PS BF	PS BF
Clear Queue Message (0Eh)	PS BF	PS BF	PS BF	PS BF	PS BF	PS BF	PS BF	PS BF	PS BF
Any Unsupported or Illegal Message	PS BF	MR (23)	MR (23)	MR (23)	MR (23)	MR (23)	MR (23)	MR (23)	MR (23)
Target Detected SCSI Parity Error During Command	na	na	na	RP (5) SS CHK (19)	na	na	na	na	na
Target Detected SCSI Parity Error During Message Out (response to ATN)	RMO (1) PS BF	RMO (2) SS1 BF	RMO (3) SS BF	RMO (4) SS BF	SS BF	RMO (6) SS BF	RMO (7) SS BF	RMO (8) SS BF	RMO (9) SS BF

Table 158. Message State/Action Table (Part 2)

SCSI Phase or State Interrupted	Message In Sync Data Xfer Request (01h,01b) (Initiator Started)	Message In Sync Data Xfer Request (01h,01h) (Target Started)	Message In Wide Data Xfer Request (01h,03b) (Initiator Started)	Message In Wide Data Xfer Request (01h,03b) (Target Started)	Data In Phase for Logical Block (Drive) Data	Data Out Phase for Logical Block (Drive) Data	Data In Phase for Command Parameter/Sense Data	Data Out Phase for Command Parameter/Sense Data	Message In Ignore Wide Residue (23h)
SCSI State Number	10	11	13	14	15	17	18		
Valid Identify (80H-87H, C0H-C7H)	SVD (25)	AT SVD (25)	DW SVD SM (11)	SVD SS CHK (19)	SVD SS CHK (19)	SVD (25)	SVD (25)		SVD (25)
Invalid Identify with Reserved Bits = 1	SS CHK	AT SS CHK	DW SS CHK	SS CHK	SS CHK	SS CHK	SS CHK		SS CHK
Invalid Identify with Different LUN	SS BF	AT SS BF	DW SS BF	SS BF	SS BF	SS BF	SS BF		SS BF
Queue Tag Message (20h, 21h, 22h)	MR (23)	AT MR (23)	DW MR (23)	MR SS CHK (19)	MR SS CHK (19)	MR (23)	MR (23)		MR (23)
Target Transfer Disable Message (13h)	MR (23)	AT MR (23)	DW MR (23)	MR SS CHK (19)	MR SS CHK (19)	MR (23)	MR (23)		MR (23)
Continue I/O Process Message (12h)	MR (23)	AT MR (23)	DW MR (23)	MR SS CHK (19)	MR SS CHK (19)	MR (23)	MR (23)		MR (23)
Sync Data Transfer Request (01h,01h) with Acceptable Transfer Mode	SM ET (10)	ET NP	DW SM ET (10)	SM ET SS CHK (19)	SM ET SS CHK (19)	SM ET (10)	SM ET (10)		SM ET (10)
Sync Data Transfer Request (01h,01h) with Unacceptable Transfer Mode	AT SM (10)	AT MR (23)	DW AT SM (10)	AT SM SS CHK (19)	AT SM SS CHK (19)	AT SM (10)	AT SM (10)		AT SM (10)
Wide Data Transfer Request (01h,03b)	AT EW SW (12)	AT EW SW (12)	AT EW SM (11)	AT EW SW SS CHK (19)	AT EW SW SS CHK (19)	AT EW SW (12)	AT EW SW (12)		AT EW SW (12)
Initiator Detected Error (05H)	SS CHK (19)	AT SS CHK (19)	DW SS CHK (19)	SS CHK (19)	SS CHK (19)	SS CHK (19)	SS CHK (19)		SS CHK (19)
Abort (06H)	PS BF	AT PS BF	DW PS BF	PS BF	PS BF	PS BF	PS BF		PS BF
Message Reject (07H)	AT NP	AT NP	DW NP	MR SS CHK (19)	MR SS CHK (19)	MR (23)	MR (23)		1W (18) SS BF
No Operation (NOP) (08H)	NP	AT NP	DW SM (11)	SS CHK (19)	SS CHK (19)	NP	NP		NP
Message Parity Error (09H)	SM (10) AT SS BF	SM (11) AT SS BF	SW (13) DW SS BF	SS BF	SS BF	SS BF	SS BF		1W (18) SS BF
Bus Device Reset (0CH)	RST BF	RST BF	RST BF	RST BF	RST BF	RST BF	RST BF		RST BF
Abort Tag Message (0Dh)	PS BF	AT PS BF	DW PS BF	PS BF	PS BF	PS BF	PS BF		PS BF
Clear Queue Message (0Eh)	PS BF	AT PS BF	DW PS BF	PS BF	PS BF	PS BF	PS BF		PS BF
Any Unsupported or Illegal Message	MR (23)	AT MR (23)	DW MR (23)	MR SS CHK (19)	MR SS CHK (19)	MR (23)	MR (23)		MR (23)
Target Detected SCSI Parity Error During Command	na	na	na	na	na	na	na		na
Target Detected SCSI Parity Error During Message Out (response to ATN)	RMO (10) AT SS BF	RMO (11) AT SS BF	RMO (13) DW SS BF	RMO (14) SS BF	RMO (15) SS BF	RMO (17) SS BF	RMO (16) SS BF		RMO (18) SS BF

Table 159. Message State/Action Table (Part 3)

SCSI Phase or State Interrupted	Status Phase	Message In Restore Pointers (03b) for Status Phase	Message In Command Complete (00h)	Message In Linked Command Complete (0Ah or 0Bh)	Message In Message Reject (07h)	Message In Disconnect (04h) during Target Transfer Disable sequence	ATN Asserted Between Phases
SCSI State Number	19	20	21	22	23	24	25
Valid Identify (80H-87H, C0H-C7H)	SVD (25)	SVD (25)	SVD (25)	SVD (25)	SVD (25)	SVD (25)	SVD (25)
Invalid Identify with Reserved Bits = 1	SS BF	SS BF	PS BF	SS BF	SS CHK	SS CHK	SS CHK
Invalid Identify with Different LUN	SS BF	SS BF	SS BF	SS BF	SS BF	SS BF	SS BF
Queue Tag Message (20h, 21h, 22h)	MR (23)	MR (23)	MR (23)	MR (23)	MR (23)	MR (23)	MR (23)
Target Transfer Disable Message (13h)	MR (23)	MR (23)	MR (23)	MR (23)	MR (23)	MR (23)	MR (23)
Continue I/O Process Message (12h)	MR (23)	MR (23)	MR (23)	MR (23)	MR (23)	MR (23)	MR (23)
Sync Data Transfer Request (01h,01h) with Acceptable Transfer Mode	SM ET (10)	SM ET (10)	SM ET (10)	SM ET (10)	SM ET (10)	SM ET (10)	SM ET (10)
Sync Data Transfer Request (01h,01h) with Unacceptable Transfer Mode	AT SM (10)	AT SM (10)	AT SM (10)	AT SM (10)	AT SM (10)	AT SM (10)	AT SM (10)
Wide Data Transfer Request (01h,03h)	AT EW SW (12)	AT EW SW (12)	AT EW SW (12)	AT EW SW (12)	AT EW SW (12)	AT EW SW (12)	AT EW SW (12)
Initiator Detected Error (05H)	RP (20)	SS BF	PS BF	SS BF	SS CHK (19)	SS CHK (19)	SS CHK (19)
	SS BF	SS BF	PS BF	SS BF	SS BF	SS BF	PS BF
Abort (06H)	PS BF	PS BF	PS BF	PS BF	PS BF	PS BF	PS BF
Message Reject (07H)	MR(23)	SS BF	PS BF	SS BF	SS BF	DATA (14-17)	MR(23)
No Operation (NOP) (08H)	NP	NP	NP	NP	NP	NP	NP
Message Parity Error (09H)	SS BF	SS BF	CC (21)	LCC (22)	MR (23)	DM (24)	SS BF
	SS BF	SS BF	SS BF	SS BF	SS BF	SS BF	SS BF
Bus Device Reset (0CH)	RST BF	RST BF	RST BF	RST BF	RST BF	RST BF	RST BF
Abort Tag Message (0Dh)	PS BF	PS BF	PS BF	PS BF	PS BF	PS BF	PS BF
Clear Queue Message (0Eh)	PS BF	PS BF	PS BF	PS BF	PS BF	PS BF	PS BF
Any Unsupported or Illegal Message	MR (23)	MR (23)	MR (23)	MR (23)	MR (23)	MR (23)	MR (23)
Target Detected SCSI Parity Error During Command	na	na	na	na	na	na	na
Target Detected SCSI Parity Error During Message Out (response to ATN)	RMO (19)	SS BF	RMO (21)	RMO (22)	RMO (23)	RMO (24)	RMO (25)
	SS BF	SS BF	SS BF	SS BF	SS BF	SS BF	SS BF

The following points further describe the Target's response to inputs that affect the SCSI message systems.

- Acceptable messages following Selection

The first message sent from the Initiator to the Target following a Selection phase with the ATN signal active must be the Identify, Abort, or Bus Device Reset message. If any other message is received, the Target changes to the Bus Free phase to signal a catastrophic error condition.

- Messages following Identify

The Identify message establishes the I_T_L nexus. The Identify message may be immediately followed by other messages, such as a Queue Tag message, a Target Transfer Disable Message, a Continue I/O Process Message, or the first message of a pair of Synchronous Data Transfer Request messages.

- Queue Tag Messages with Tagged Queuing disabled

Any Queue Tag Message received while Tagged Queuing is disabled is treated like an unsupported message.

- Actions after an Incorrect Initiator Connection

If an Initiator establishes an incorrect connection (see 4.1.3, “Incorrect Initiator Connection” on page 199), the drive will attempt to return check condition status to indicate this condition. The check condition status for this condition will have priority over every BUS FREE action in the message state action table except for the BUS FREE following the Bus Device Reset Message.

- Messages without properly negated ATN

The Initiator is required to end the Message Out phase (by negating ATN) when it sends certain messages (see 3.1, “Supported Messages” on page 167). If the Initiator fails to negate the ATN signal to end the Message Out phase following these messages, the Target changes to the Bus Free phase to signal a catastrophic error condition.

- Retry for unsupported messages

If the ATN signal remains asserted following the receipt of an unsupported message, the Target will Message Reject the unsupported message. If the ATN signal is still asserted, the Target changes to the Message Out phase to receive the next message from the Initiator.

3.6 SCSI Bus Related Error Handling Protocol

This protocol is used to handle errors that threaten the integrity of a connection between the Target and an Initiator.

3.6.1 Unexpected Bus Free Phase Error Condition

There are several error conditions that cause the Target to immediately change to the Bus Free phase, regardless of the state of the ATN signal. The Target does not attempt to reconnect to the Initiator to complete the operation that was in progress when the error condition was detected. The Initiator should interpret this as a catastrophic error condition.

If the LUN was identified by the Target prior to the error condition, then the Target aborts the command and generates sense data for this Initiator/LUN to describe the

cause of the catastrophic error. The Initiator may retrieve this sense data by issuing a Request Sense command to this LUN.

Note: The Request Sense command may fail if the catastrophic error condition persists.

If the LUN was not identified by the Target prior to the error condition, then the Target does not affect the sense data or the operation of any currently executing command for this Initiator or any other Initiator.

3.6.2 Message Out Phase Retry

A Message Out phase retry may be caused by a Target detected parity error during the Message Out phase.

When an error occurs for the first time, the Target retries the Message Out phase as follows:

- Continue the REQ/ACK handshakes in the Message Out phase until the Initiator negates the ATN signal. The Target ignores all the remaining Message Out phase bytes received after the parity error is detected until the ATN signal is negated.
- Assert the REQ signal prior to changing to any other phase. After detecting this condition, the Initiator must resend all of the previous message byte(s) sent during this continuous Message Out phase. The Target assumes that the message byte(s) are sent in the same order as previously sent during this phase. The Target does not act on any message which it acted on the first time received. When resending more than one message byte, the Initiator must assert the ATN signal prior to asserting ACK for the first message byte and must maintain ATN asserted until the last message byte is sent, as described in 3.3, “Attention Condition” on page 182.
- Repeat the transfer of the Message Out phase byte(s). If the Target receives all of the message byte(s) successfully (without detecting a parity error), it indicates that it does not wish to retry the Message Out phase by changing to any other information transfer phase and transferring at least one byte. The Target may also indicate that it has successfully received an Abort, Abort Tag, Clear Queue or Bus Device Reset message by changing to the Bus Free phase.

Note: This situation is indistinguishable from a second Message Out phase parity error, detected while attempting to receive an Abort, Abort Tag, Clear Queue or Bus Device Reset message.

When an error occurs as a result of a retry and the LUN has been previously identified, the Target terminates the current command as follows:

- Change to the Bus Free phase, regardless of the state of the ATN signal. This signals a catastrophic error condition to the Initiator.
- Abort the command and set the sense data to Aborted Command/Interface Parity Error (0Bh/47h).

When an error occurs as a result of a retry and the LUN has not been previously identified, the Target terminates the current command as follows:

- Change to the Bus Free phase, regardless of the state of the ATN signal. This signals a catastrophic error condition to the Initiator.

- The Target does not affect the sense data or the operation of any currently executing command for this Initiator or any other Initiator.

3.6.3 Message In Phase Retry

A Message In phase retry may be caused by a Target receipt of a Message Parity Error message immediately following a Message In phase. The Initiator may send the Message Parity Error message as a result of an Initiator detected SCSI bus parity error during the Message In phase.

When an error occurs for the first time, the Target retries the Message In phase as follows:

- Change to the Message In phase and repeat the transfer of the last message sent to the Initiator. If the last message sent to the Initiator was an extended message, then multiple bytes are sent to repeat the transfer of the entire extended message.

When an error occurs as a result of a retry, the Target terminates the current command as follows:

- Change to the Bus Free phase, regardless of the state of the ATN signal. This signals a catastrophic error condition to the Initiator.
- Abort the command and set the sense data to Aborted Command/Interface Parity Error (0Bh/47h).

3.6.4 Command Phase Retry

A Command Phase Retry may be caused by a Target detected SCSI bus parity error during the Command phase or a Target receipt of an Initiator Detected Error message immediately following the Command phase. The Initiator may send the Initiator Detected Error message as a result of an Initiator internal error, detected during the Command phase.

When an error occurs for the first time and the LUN has been previously identified by an Identify message, the Target retries the Command phase as follows:

- Change to the Message In phase and send a Restore Pointers message to the Initiator.
- If the Initiator Message Rejects the Restore Pointers message, then the Target terminates the Command phase retry and responds as defined for an error detected during the Command phase retry. If the Initiator accepts the Restore Pointers message, then the Target repeats the transfer of the Command phase bytes.

When an error occurs during a Command phase retry and the LUN has been previously identified by an Identify message, the Target terminates the current command as follows:

- Send Check Condition status followed by Command Complete message to the Initiator.
- Abort the command and set the sense data based on the cause of the error that interrupted the Command phase. The sense data is set to Aborted Command/Interface Parity Error (0Bh/47h) for a Target detected SCSI bus parity error or Aborted Command/Initiator Detected Error (0Bh/48h) for an Initiator Detected Error message.

If this is the first error for retry and the LUN has not been previously identified by an Identify message, the Target terminates the current command as follows:

- Change to the Bus Free phase to signal a catastrophic error condition to the Initiator.
- The Target does not affect the sense data or the operation of any currently executing command for this Initiator or any other Initiator.

3.6.5 Status Phase Retry

A Status phase retry may be caused by a Target receipt of an Initiator Detected Error message immediately following the Status phase. The Initiator may send the Initiator Detected Error message as a result of a SCSI bus parity error or internal error, detected by the Initiator during the Status phase.

The first time an error occurs the Target retries the Status phase as follows:

- Change to the Message In phase and send a Restore Pointers message to the Initiator.
- If the Initiator Message Rejects the Restore Pointers message, then the Target terminates the Status phase retry and responds as defined for an error detected during the Status phase retry. If the Initiator accepts the Restore Pointers message, the Target repeats the transfer of the Status phase byte.

When an error occurs during a Status phase retry, the Target terminates the current command as follows:

- Change to the Bus Free phase, regardless of the state of the ATN signal. This signals a catastrophic error condition to the Initiator.
- Abort the command and set the sense data to Aborted Command/Initiator Detected Error (0Bh/48h).

3.6.6 Data Out Phase Retry

Data Out phase retries are not supported. If an error occurs during a Data Out phase, the Target terminates the current command as follows:

- Send Check Condition status followed by Command Complete message to the Initiator.
- Abort the command and set the sense data based on the cause of the error which interrupted the Data Out phase. The sense data is set to Aborted Command/Interface Parity Error (0Bh/47h) for a Target detected SCSI bus parity error, Hardware Error/Internal Controller Error (04h/44h) for a Target detected internal error, or Aborted Command/Initiator Detected Error (0Bh/48h) for an Initiator Detected Error message.

3.6.7 Data In Phase Retry

Data In phase retries are not supported. If an error occurs during a Data In phase, the Target terminates the current command as follows:

- Send Check Condition status followed by Command Complete message to the Initiator.
- Abort the command and set the sense data based on the cause of the error which interrupted the Data In phase. The sense data is set to Hardware Error/Internal Controller Error (04h/44h) for a Target detected internal error, or

Aborted Command/Initiator Detected Error (0Bh/48h) for an Initiator Detected Error message.

3.6.8 Identify Message In Phase Retry

An Identify Message In retry may be caused by a Target receipt of the Message Reject or Message Parity Error message immediately following an Identify Message In phase.

When an error occurs for the first time the Target retries the Identify Message In phase as follows:

- Change to the Message In phase and repeat the transfer of the Identify message to the Initiator.

When an error occurs as a result of a retry, the Target terminates the current command as follows:

- Change to the Bus Free phase, regardless of the state of the ATN signal. This signals a catastrophic error condition to the Initiator.
- Abort the command and set the sense data to Aborted Command/Message Error (0Bh/43h) or Aborted command/parity error (0Bh/47h).

3.6.9 Simple Queue Tag Message In Phase Retry

A Simple Queue Tag Message In retry may be caused by a Target receipt of the Message Reject or Message Parity Error message immediately following a Simple Queue Tag Message In phase.

When an error occurs for the first time the Target retries the Simple Queue Tag message In phase as follows:

- Change to the Message In phase and repeat the transfer of the Simple Queue Tag message to the Initiator.

When an error occurs as a result of a retry, the Target terminates the current command as follows:

- Change to the Bus Free phase, regardless of the state of the ATN signal. This signals a catastrophic error condition to the Initiator.
- Abort the command and set the sense data to Aborted Command/Message Error (0Bh/43h) or Aborted command/parity error (0Bh/47h).

4.0 Additional Information

This chapter provides additional information or descriptions of various functions, features, or operating modes supported by the Target that are not fully described in previous chapters.

4.1 SCSI Protocol

There are various operating conditions that prevent the Target from executing a SCSI command. This section describes each of these operating conditions and their relative priority.

4.1.1 Priority of SCSI Status Byte Reporting

After establishing the I_T_L nexus or I_T_L_Q nexus, the Target must first determine whether command execution is allowed. Execution is deferred until a later time if the command must be added to the command queue. Execution may also be prevented by an internal Target condition that requires the reporting of a *Check Condition Status*, *Busy Status*, *Reservation Conflict Status*, or *Queue Full Status*. There are several different internal conditions that may cause *Check Condition Status* to be reported and Sense data to be generated. It is possible for more than one of these conditions to exist at the same time. The order in which the Target checks for each of these conditions determines their priority (highest priority first) as follows:

1. *Check Condition Status* for Invalid Logical Unit Number (see 4.1.2, “Invalid LUN Processing” on page 198)
2. *Check Condition Status* for Incorrect Initiator Connection (see 4.1.3, “Incorrect Initiator Connection” on page 199)
3. *Busy Status* or *Queue Full Status*, or add command to command queue (see 4.1.4, “Command Processing During Execution of Active I/O Process” on page 200)
4. *Check Condition Status* for Unit Attention condition (see 4.1.5, “Unit Attention Condition” on page 202)
5. *Check Condition Status* during start-up or format operations (see 4.1.6, “Command Processing During Start-up and Format Operations” on page 205)
6. *Check Condition Status* for Internal Error condition (see 4.1.7, “Internal Error Condition” on page 206)
7. *Check Condition Status* for Deferred Error condition (see 4.1.8, “Deferred Error Condition” on page 207)
8. *Check Condition Status* for Degraded Mode condition (see 4.1.9, “Degraded Mode” on page 208)
9. *Reservation Conflict Status* (see 4.1.10, “Command Processing While Reserved” on page 219)
10. *Check Condition Status* for invalid command opcode
11. *Check Condition Status* for invalid command descriptor block

The highest priority internal condition that prevents command execution is reported by the Target, provided there is no bus error.

For all Check Conditions, Sense data is built by the Target provided a valid LUN address is known. Sense data is cleared by the Target upon receipt of any subsequent command to the LUN from the Initiator receiving the *Check Condition Status*.

4.1.2 Invalid LUN Processing

An invalid LUN may be identified by the Target after receiving the first Identify message or the CDB if no previous Identify message has been received. If an Identify message is received prior to the Command phase, then the LUN specified in the CDB is ignored. The Target accepts the first Identify message with an invalid LUN, without returning a Message Reject message. The Target also continues to the Command phase to receive the CDB from the Initiator.

The Target's response to an invalid LUN varies with the command, as follows:

Inquiry	Execute the command, return the Inquiry data that indicates unknown device type (byte 0 = 7Fh), and return <i>Good Status</i> . All other bytes are valid (see 1.3, "Inquiry" on page 30).
Request Sense	Execute the command, return the sense data with the Sense Key set to <i>Illegal Request</i> and the Additional Sense Code and Qualifier set to <i>Logical Unit Not Supported</i> , and return <i>Good Status</i> (see also 1.20, "Request Sense" on page 139).
All Others	Do not execute the command and return <i>Check Condition Status</i> . Since the Initiator is not addressing a valid LUN, no Sense data is built for the failed command.

In all cases, the Target's response to the command for an invalid LUN does not affect the current execution of a command on a valid LUN for this Initiator or any other Initiator.

An Identify message with a different LUN from the one in the first Identify message may be received before a Bus Free phase has occurred. In this case, the second LUN is considered to be invalid. This causes the Target to go to the Bus Free phase to signal a catastrophic error.

4.1.3 Incorrect Initiator Connection

It is an *Incorrect Initiator Connection* error if any of the following occurs:

- an Initiator attempts to establish an I_T_L nexus when an I/O process (either queued or active) with an I_T_L nexus already exists from a previous connection with the same Initiator

Note: It is not an Incorrect Initiator Connection to reconnect to an already established I_T_L nexus if it is in order to send an *Abort*, *Abort Tag*, *Continue I/O Process*, *Clear Queue*, or *Bus Device Reset* message during the same MESSAGE OUT phase as the *Identify* message.

- an Initiator attempts to establish an I_T_L_Q nexus when an I_T_L nexus already exists from a previous connection with the same Initiator
- an Initiator attempts to establish an I_T_L nexus when an I_T_L_Q nexus already exists from a previous connection with the same Initiator

Note: It is not an Incorrect Initiator Connection to send a Request Sense command without a Queue Tag message when sense is pending on the logical unit for the Initiator that issues the Request Sense command.

- an Initiator attempts to establish an I_T_L_Q nexus when an I/O process (either queued or active) with the same I_T_L_Q nexus already exists from a previous connection

Note: It is not an Incorrect Initiator Connection to reconnect to an already established I_T_L_Q nexus if it is in order to send an *Abort*, *Abort Tag*, *Continue I/O Process*, *Clear Queue*, or *Bus Device Reset* message during the same MESSAGE OUT phase as the *Identify* message.

If any of the above errors occur, all queued I/O processes and active I/O processes associated with the issuing Initiator on the specified logical unit are terminated. The current I/O process is ended with a *Check Condition Status*, the sense key is set to *Aborted Command* and the additional sense code is set to *Overlapped Commands Attempted*. Status is only returned for the current I/O process.

4.1.4 Command Processing During Execution of Active I/O Process

When the Target is not executing any active I/O processes, a new I/O process is permitted to execute (unless execution is prevented by another internal Target condition listed in 4.1.1, “Priority of SCSI Status Byte Reporting” on page 197).

If an active I/O process does exist when the Target receives a new command, then the Target determines if:

- *Check Condition Status* with Sense Key = **Aborted Command** is returned for an **Overlapped Commands Attempted** error
- the command is permitted to execute
- the command is added to the command queue
- *Queue Full Status* is returned
- *Busy Status* is returned

If an active I/O process does exist when the Target receives a new command, then the Target determines how the new command should be handled based on the following rules:

- *Check Condition Status* is returned with Sense Key set to **Aborted Command** for an **Overlapped Commands Attempted** error if:
 - See 4.1.3, “Incorrect Initiator Connection” on page 199 for the conditions which cause this error.
- The command is permitted to execute if:
 - the command is an Inquiry or Request Sense command. (see 4.2, “Priority Commands” on page 220.)
- *Check Condition Status* is returned with Sense Key set to **Logical Unit Not Ready** if:
 - the start-up operation or format operation is an active process. See 4.1.6, “Command Processing During Start-up and Format Operations” on page 205 for the exact conditions which cause this response.
Note: If a Unit Attention is pending when this condition exists, the Sense Key is set to **Unit Attention** rather than **Logical Unit Not Ready** since Unit Attention has a higher reporting priority. (See 4.1.1, “Priority of SCSI Status Byte Reporting” on page 197).
- The command is permitted to execute if:
 - the conditions to execute concurrently are met. (See 4.4, “Concurrent Command Processing” on page 224).
- The command is added to the command queue for an I_T_L nexus if:
 - no Queue Tag message was received during the connection which established the I/O process, and
 - disconnection is allowed for the current I/O process, and
 - there is no queued I/O process or active I/O process corresponding to the I_T_L nexus for the current I/O process, and
 - the command is not linked to a previous command.
- The command is added to the command queue for an I_T_L_Q nexus if:

- a Queue Tag message was received during the connection which established the I/O process, and
 - Tagged Queuing is enabled (DQue = 0), and
 - an I/O process (either active or queued) exists at the Target, and
 - disconnection is allowed for the current I/O process, and
 - there is no queued I/O process or active I/O process corresponding to the I_T_L_Q nexus for the current I/O process, and
 - the command is not linked to a previous command.
- *Queue Full Status* is returned if:
 - the command would otherwise be queued (according to the rules described above) but the command queue is full and all slots are utilized, or
 - the command would otherwise be queued (according to the rules described above) but all of the available command queue slots not reserved for use by another Initiator are utilized, or
 - Tagged Queuing is enabled (DQue = 0) and a Format Unit command was previously queued but has not yet begun execution, or
 - Tagged Queuing is enabled (DQue = 0), the Target is in a Degraded Mode (see 4.1.9, “Degraded Mode” on page 208), and a Start Unit command was previously queued but has not yet begun execution.
 - *Busy Status* is returned if:
 - Tagged Queuing is disabled (DQue = 1) and a Format Unit command was previously queued but has not yet begun execution, or
 - Tagged Queuing is disabled (DQue = 1), the Target is in a Degraded Mode (see 4.1.9, “Degraded Mode” on page 208), and a Start Unit command was previously queued but has not yet begun execution, or
 - the command would otherwise be queued (according to the rules described above) but disconnection is not allowed for the current I/O process.

If a command is queued, command execution may still be prevented at a later time when the command is dequeued to become an active I/O process. This occurs if command execution is prevented by another internal Target condition listed in 4.1.1, “Priority of SCSI Status Byte Reporting” on page 197 at the time the command is dequeued.

4.1.5 Unit Attention Condition

The Target generates a Unit Attention condition when one of the following occurs:

- Target has been reset

This includes Power-On reset, SCSI Bus reset, Bus Device Reset message, or Self Initiated reset. In all of these cases, a Unit Attention condition is generated for each Initiator. The Additional Sense Code and Additional Sense Code Qualifier reported is ***Power On, Reset, or Bus Device Reset occurred***.

- Mode Select command has been executed

In this case, a Unit Attention condition is generated for all Initiators except the one that issued the Mode Select command. The Additional Sense Code and Additional Sense Code Qualifier reported is ***Mode Parameters Changed***. The Unit Attention condition is generated if any of the current page parameters are set by the Mode Select command. The Target does not check to see that the old parameters are different from the new parameters. For example: If the Initiator issues a Mode Sense command with a page code to report the current values followed by a Mode Select command with the same parameter list, a Unit Attention condition is generated despite the fact that the current parameters were not changed from their previous value. However, if the Target detects an illegal parameter or error condition prior to modifying the current parameters, a Unit Attention condition is not generated since the parameters were not set. The Unit Attention condition is also not generated if the Mode Select command parameter list does not include any pages and only the header or header/block descriptor is present.

- Format Unit command has been executed

In this case, a Unit Attention condition is generated for all Initiators except the one that issued the Format Unit command. The Additional Sense Code and Additional Sense Code Qualifier reported is ***Not Ready To Ready Transition, (Medium may have changed)***. This indicates that the block descriptor parameters from the last Mode Select command have been used and are now considered current values.

- Write Buffer command to download microcode has been executed

In this case, a Unit Attention condition is generated for all Initiators except the one that issued the Write Buffer command. The Additional Sense Code and Additional Sense Code Qualifier reported is ***Microcode has been changed***.

- Commands Cleared by a Clear Queue Message

This Unit Attention condition is generated after an Initiator sends a Clear Queue Message. The Unit Attention condition is generated for all other Initiators with I/O processes that were either active or queued for the logical unit. The Additional Sense Code and Additional Sense Code Qualifier reported is ***Commands Cleared by Another Initiator***.

- Spindles Synchronized

This Unit Attention is generated when the Drive enters the spindle motor synchronization state. In this case, a Unit Attention condition is generated for all Initiators. The Additional Sense Code and Additional Sense Code Qualifier reported is ***Spindles Synchronized***. When this Unit Attention is generated, the Unit Attention for Spindles not Synchronized is cleared (they are mutually exclusive). See 4.5, “Motor Synchronization” on page 225 for more information on this Unit Attention.

- Spindles Not Synchronized

This Unit Attention is generated when the Drive could not enter into or falls out of the spindle motor synchronization state. If the Drive could not enter into the synchronization state, a Unit Attention condition is generated for all Initiators. If the Drive falls out of the synchronization state, a Unit Attention condition is generated for Initiators other than the first Initiator to detect the synchronization error. The Additional Sense Code and Additional Sense Code Qualifier reported is *Spindles Not Synchronized*. When this Unit Attention is generated, the Unit Attention for Spindles Synchronized is cleared (they are mutually exclusive). See 4.5, “Motor Synchronization” on page 225 for more information on this Unit Attention.

The Unit Attention condition persists for each Initiator until that Initiator clears the condition from the logical unit as described below. Several commands are handled as special cases during a Unit Attention condition. These cases are also discussed below.

If the Target receives a command from an Initiator before reporting a *Check Condition Status* for a pending Unit Attention condition for that Initiator, the Target's response varies with the command as follows:

Inquiry	Execute the command, return <i>Good Status</i> , and preserve the Unit Attention condition.
Request Sense	Execute the command, return any pending sense data, return <i>Good Status</i> , and preserve the Unit Attention condition. If there is not any pending sense data, the sense data associated with the highest priority Unit Attention condition is returned and the highest priority Unit Attention condition is cleared for this Initiator.
All Others	Do not execute the command, return a <i>Check Condition Status</i> , and clear the highest priority Unit Attention condition for this Initiator. If the following command from this Initiator is Request Sense, then the sense data associated with the highest priority Unit Attention condition is returned. Otherwise, it is lost.

The Target's response to the next command received from an Initiator after reporting a *Check Condition Status* for a pending Unit Attention condition for that Initiator, varies with the command as follows:

Inquiry	Execute the command, return <i>Good Status</i> , and preserve any lower priority Unit Attention condition(s) for that Initiator (sense data for the highest priority Unit Attention condition is lost).
Request Sense	Execute the command, return a Sense key of <i>Unit Attention</i> and Additional Sense Code and Qualifier that corresponds to the highest priority Unit Attention condition, return <i>Good Status</i> , and preserve any lower priority Unit Attention condition(s).
All Others	Execute the command unless prevented by another higher priority status (see 4.1.1, “Priority of SCSI Status Byte Reporting” on page 197 for more information) or another lower priority Unit Attention Condition, and return the

appropriate status for the command. (Sense data for the highest priority Unit Attention condition is lost).

More than one Unit Attention condition may be generated for an Initiator before that Initiator clears the Unit Attention condition. Each Unit Attention condition is reported one at a time until they all have been reported and cleared. The highest priority Unit Attention condition is reported first. The order in which the Target checks for each Unit Attention condition determines their priority (highest priority first) as follows:

1. Reset (Target has been reset)
2. Mode Select Parameters Changed (Mode Select command has been executed.)
3. Not Ready To Ready Transition (Medium May Have Changed) (Format Unit command has been executed.)
4. Microcode Has Been Changed (Write Buffer command to download microcode has been executed.)
5. Commands Cleared By Another Initiator (Commands Cleared by a Clear Queue Message)
6. Spindles Synchronized
7. Spindles Not Synchronized

4.1.6 Command Processing During Start-up and Format Operations

If the Target receives a command from an Initiator while the Target is executing a start-up operation and the Target is in a Degraded Mode (see 4.1.9, “Degraded Mode” on page 208), or is executing a format operation, the Target's response varies with the command as follows:

Inquiry	Execute the command and return <i>Good Status</i> .
Request Sense	Execute the command, return a Sense key of <i>Not Ready</i> and an Additional Sense code of <i>Logical Unit Not Ready</i> and return <i>Good Status</i> . The Additional Sense code Qualifier that is returned is dependent on type of I/O processes that are active: For the Start/Stop Unit command and the Auto-start operation, the qualifier returned is <i>logical unit is in the process of becoming ready</i> . For the Format Unit command, the qualifier returned is <i>Logical Unit Not Ready, Format in Progress</i> , and the Sense key specific bytes are set to return the progress indication.
Start/Stop Unit	If the start-up operation is an active process and a Start/Stop Unit command (either active or queued) does not exist at the Target from this Initiator, and disconnection is allowed for the current I/O process then: The command is added to the command queue. Otherwise: Do not execute the command and return <i>Check Condition Status</i> . The Sense data generated is described in Request Sense above.
All Others	Do not execute the command and return <i>Check Condition Status</i> . The Sense data generated is described in Request Sense above.

4.1.7 Internal Error Condition

The Target generates an Internal Error condition for all Initiators when:

- an internally initiated operation completes with an unrecoverable error.

The following is a list of internally initiated error conditions:

- During the execution of the start-up sequence for Auto Start (to automatically start the spindle motor) after the SCSI bus has been enabled and prior to completion of the bring-up sequence.
 - Following a SCSI Hardware reset or a SCSI Bus Device Reset message if the reset was received during a start-up sequence with the Auto Start function enabled. The start-up sequence is executed if it has not been previously executed and completed.
- an unrecoverable error occurs during an internal Target idle time function

An Internal Error condition causes Sense data to be generated and saved for all Initiators. The Error Code field of the Sense data is set for a Current Error (70h) and the Sense Key is set to HARDWARE ERROR. Recovered errors are not reported. Any outstanding Deferred Error condition is cleared for all Initiators and the associated Sense data is lost. (The Internal Error condition and Deferred Error condition are mutually exclusive.)

The Internal Error condition persists for each Initiator until that Initiator clears the condition from the logical unit as described below. Several commands are handled as special cases during an Internal Error condition. These cases are also discussed.

If the Target receives a command from an Initiator while an Internal Error condition exists for that Initiator, the Target's response varies with the command as follows:

Inquiry	Execute the command, return <i>Good Status</i> , and do not clear the Internal Error condition.
Request Sense	Execute the command, return the sense data generated by the Internal Error condition, return <i>Good Status</i> , and clear the Internal Error condition for that Initiator.
All Others	Do not execute the command, return <i>Check Condition Status</i> , and clear the Internal Error condition. If the following command from this Initiator is Request Sense, then the sense data associated with the Internal Error condition is returned. Otherwise, it is lost.

4.1.8 Deferred Error Condition

The Target generates a Deferred Error condition for all Initiators when:

- an external initiated operation completes in error.

The following is a list of external conditions:

- During the execution of an immediate Start/Stop Unit command after *Good Status* has been returned and prior to completing the start unit operation.
- During the execution of an immediate Format Unit command after *Good Status* has been returned and prior to completing the format operation.
- In the case of write caching, during execution of a Write command after *Good Status* has been returned and prior to writing the data to the media.

A Deferred Error condition causes Sense data to be generated and saved for all Initiators. The Error Code field (byte 0) of the Sense data is set for a Deferred Error (71h) and the Sense Key is set to either RECOVERED ERROR, MEDIUM ERROR, or HARDWARE ERROR. Both recoverable and unrecoverable errors are reported. Any outstanding Internal Error condition is cleared for all Initiators and the associated Sense data is lost. (The Internal Error condition and Deferred Error condition are mutually exclusive.)

The Deferred Error condition persists for each Initiator until that Initiator clears the condition from the logical unit as described below. Several commands are handled as special cases during a Deferred Error condition. These cases are also discussed.

If the Target receives a command from an Initiator while Deferred Error condition exists for that Initiator, the Target's response varies with the command as follows:

Inquiry	Execute the command, return <i>Good Status</i> , and do not clear the Deferred Error condition.
Request Sense	Execute the command, return the Sense data generated by the Deferred Error condition, return <i>Good Status</i> , and clear the Deferred Error condition for that Initiator.
All Others	Do not execute the command, return <i>Check Condition Status</i> , and clear the Deferred Error condition. If the following command from this Initiator is Request Sense, then the Deferred Error Sense data is returned. Otherwise, it is lost.

4.1.9 Degraded Mode

There are certain errors or conditions that impair the Target's ability to function normally. Rather than fail hard, the Target is designed to be as responsive as possible. Also, in most cases, some action on the part of the Initiator may be used to restore normal operation. This mode of limited operation is called Degraded Mode.

The following sections address causes of Degraded Mode, characteristics and limitations the Target has in Degraded Mode, and actions that may be taken to restore normal operation.

4.1.9.1 Reasons for Entering Degraded Mode

The Target enters Degraded Mode for any of the reasons shown below. Not all reasons are error conditions (for example, the Target powers up in Degraded Mode and Degraded Mode does not clear until, among other requirements, the

spindle spins up).

- The spindle motor is not spinning or is not at its proper speed. (*Motor Stop Degraded*)

The motor may not be spinning for any of several reasons:

- The motor has not spun up yet, either because the point of Auto Start has not been reached (if enabled), or because a Start/Stop Unit command has not been issued to start the motor.
- The motor has been stopped by a Start/Stop Unit command.
- A spindle failure has caused the Target to stop the spindle.
- A Self Initiated Reset has occurred.

- The configuration records have not been read or are not readable. (*Configuration Sector Degraded*)

During the execution of the start-up sequence, the Target reads a portion of its Reserved Area called the configuration records. Errors prior to this read, or a failure of the read, result in entering Degraded Mode.

- RAM microcode is not loaded. (*Microcode Degraded*)

During the execution of the start-up sequence, the Target loads its microcode from the Reserved Area. The Target enters Degraded Mode if this load cannot be achieved. Degraded Mode is also entered after failures of a microcode download operation by way of the Write Buffer command.

- Failure of a Send Diagnostic self-test, a start-up sequence, or other internal Target failures. (*Power on Self Test Degraded*)

There are several different reasons for entering this Degraded Mode. All of these reasons are related to error condition and failures within the Target. The reasons for entering this degraded mode include the following:

- The Target does extensive self testing as part of the start-up sequence or as a result of executing the Send Diagnostic command with the SlfTst option. A failure of either of these tests places the Target in this Degraded Mode.
- The Target reads and/or writes various data records in the Reserved Area of the Drive during the start-up sequence, while executing certain SCSI commands, or while performing internal Idle Time functions. Any failures to read or write any of these data records at any time, result in entering this Degraded Mode.

- The Target periodically adjusts the track following position for each data head to compensate for disk movement. If one of these adjustments fails, the Target enters this degraded mode to prevent writing data off-track.
- A Format Unit or Reassign Blocks command, or an automatic reallocation failed or was abnormally terminated. (*Format Degraded, Reassign Degraded*)

Format Unit, Reassign Blocks, and automatic reallocation operations must complete successfully for the Drive to be useable. If one of these operations fail or is terminated by a reset, a Bus Device Reset or Abort message, a Self Initiated Reset, a loss of power, or certain SCSI errors, the Target enters Degraded Mode.

4.1.9.2 Limitations of the Drive While in Degraded Mode

Several commands are not executed by the Target while in Degraded Mode. If Degraded Mode does not allow the command to execute, the command is failed with a Check Condition status and the appropriate Sense Data is generated. The Sense Key is set to Not Ready. The Additional Sense Code and the Additional Sense Code Qualifier is dependent on the type of Degraded Mode as summarized below.

More than one Degraded Mode may exist at the same time. Only the highest priority Degraded Mode that prevents command execution is reported to the Initiator. The order in which the Target checks for each type of Degraded Mode determines their priority (highest priority first) as follows:

1. The spindle motor is not spinning or is not at its proper speed. (*Motor Stop Degraded*)

The Sense Key is *Not Ready*, with a Sense Code/Qualifier of *Logical Unit Not Ready initializing command required*.

2. The configuration records have not been read or are not readable. (*Configuration Sector Degraded*)

The Sense Key is *Not Ready*, with a Sense Code/Qualifier of *Logical Unit Failed Self-Configuration*.

3. RAM microcode is not loaded. (*Microcode Degraded*)

The Sense Key is *Not Ready*, with a Sense Code/Qualifier of *Logical Unit Failed Self-Configuration*.

4. Failure of a Send Diagnostic self-test, a start-up sequence, abnormal termination of Track Squeeze Recovery in DRP, or other internal Target failures. (*Power on Self Test Degraded*)

The Sense Key is *Not Ready*, with a Sense Code/Qualifier of *Diagnostic Failure*.

5. A Format Unit command failed or was abnormally terminated. (*Format Degraded*)

The Sense Key is *Not Ready*, with a Sense Code/Qualifier of *Medium Format Corrupted, Format Command Failed*.

6. Reassign Blocks command failed or was abnormally terminated. (*Reassign Degraded*)

The Sense Key is *Not Ready*, with a Sense Code/Qualifier of *Medium Format Corrupted, Reassign Failed*.

7. An Auto Reassign failed or was abnormally terminated. (*Reassign Degraded*)

The Sense Key is *Not Ready*, with a Sense Code/Qualifier of *Medium Format Corrupted, Reassign Failed*.

4.1.9.3 Summary of Target's response to each SCSI Command in Degraded Mode

A summary of the Target's response to each SCSI command that is received during Degraded Mode is shown in the following tables:

Inquiry, Read Buffer, Request Sense, Start/Stop Unit, or Write Buffer commands		
Degraded Mode	Description	
<ul style="list-style-type: none"> • <i>Motor Stop Degraded</i> • <i>Configuration Sector Degraded</i> • <i>Microcode Degraded</i> • <i>Power on Self Test Degraded</i> • <i>Format Degraded</i> • <i>Reassign Degraded</i> 	Executes.	
	Success:	Reports Good status.
	Failure:	Generates Check Condition

Reassign Blocks command	
Degraded Mode	Description
<ul style="list-style-type: none"> • <i>Motor Stop Degraded</i> • <i>Configuration Sector Degraded</i> • <i>Microcode Degraded</i> • <i>Power on Self Test Degraded</i> • <i>Format Degraded</i> 	Does not execute. Generates Check Condition.
<i>Reassign Degraded</i>	Executes.
	<p>Note: The LBA specified by the command must match the original LBA that was being re-assigned in order to resume the Reassign Blocks operation. Otherwise, Check Condition Status is returned and the command is not executed.</p>
	Success:
Failure:	Generates Check Condition. <i>Reassign Degraded</i> mode is not cleared.

Synchronize Cache, Write, Write Extended, Write Verify, Write Same, or Write Long command	
Degraded Mode	Description
<ul style="list-style-type: none"> • <i>Motor Stop Degraded</i> • <i>Configuration Sector Degraded</i> • <i>Microcode Degraded</i> • <i>Power on Self Test Degraded</i> • <i>Format Degraded</i> • <i>Reassign Degraded</i> 	Does not execute. Generates Check Condition.

Test Unit Ready command		
Degraded Mode	Description	
<ul style="list-style-type: none"> • <i>Motor Stop Degraded</i> • <i>Configuration Sector Degraded</i> • <i>Microcode Degraded</i> • <i>Power on Self Test Degraded</i> 	Executes. Generates Check Condition.	
<ul style="list-style-type: none"> • <i>Format Degraded</i> • <i>Reassign Degraded</i> (FRDD bit set to 0, see “?” on page ?.) 	Executes. Generates Check Condition.	
<ul style="list-style-type: none"> • <i>Format Degraded</i> • <i>Reassign Degraded</i> (FRDD bit set to 1, see 1.6.2, “Page 0 - Vendor Unique Parameters” on page 75.) 	Executes. Reports Good status or status other than Degraded Mode.	
	Success:	Reports Good status.
	Failure:	Generates Check Condition.

Format Unit command	
Degraded Mode	Description
<ul style="list-style-type: none"> • <i>Motor Stop Degraded</i> • <i>Configuration Sector Degraded</i> • <i>Microcode Degraded</i> • <i>Power on Self Test Degraded</i> 	Does not execute. Generates Check Condition.
<i>Format Degraded</i>	Executes.
	Success: Reports Good status. Clears <i>Format Degraded</i> . Clears <i>Reassign Degraded</i> if it exists internally.
	Failure: Enters <i>Format Degraded</i> mode. Generates Check Condition.
<i>Reassign Degraded</i>	Executes.
	Success: Reports good status. Clears <i>Reassign Degraded</i> mode.
	Failure: Enters <i>Format Degraded</i> mode. Generates Check Condition.

Send Diagnostics command	
Degraded Mode	Description
<ul style="list-style-type: none"> • <i>Motor Stop Degraded</i> • <i>Configuration Sector Degraded</i> • <i>Microcode Degraded</i> 	Does not execute. Generates Check Condition.
<i>Power on Self Test Degraded</i>	Executes.
	Success: Reports Good status. Clears <i>Power on Self Test Degraded</i> mode.
	Failure: Enters <i>Power on Self Test Degraded</i> mode. Generates Check Condition.
<i>Format Degraded</i>	Executes.
	Success: Reports Check Condition with <i>Format Degraded</i> mode.
	Failure: Enters <i>Power on Self Test Degraded</i> mode. Generates Check Condition.
<i>Reassign Degraded</i>	Executes.
	Success: Reports Good status. Clears <i>Reassign Degraded</i> mode.
	Failure: Generates Check Condition. Depending on the cause of the failure, <i>Power on Self Test Degraded</i> mode may be entered. <i>Reassign Degraded</i> mode is not cleared.

Read, Read Extended, Read Capacity with PMI=1, Read Long, or Verify commands	
Degraded Mode	Description
<ul style="list-style-type: none"> • <i>Motor Stop Degraded</i> • <i>Configuration Sector Degraded</i> • <i>Microcode Degraded</i> 	Does not execute. Generates Check Condition.
<i>Power on Self Test Degraded</i>	Executes.
	Success: Reports Good status.
	Failure: Generates Check Condition.
<i>Format Degraded</i>	Does not execute. Generates Check Condition with <i>Format Degraded</i> .
<i>Reassign Degraded</i>	Executes.
	Success: Reports Good status.
	Failure: Generates Check Condition.

Mode Select with Save Parameters bit = 1	
Degraded Mode	Description
<ul style="list-style-type: none"> • <i>Motor Stop Degraded</i> • <i>Configuration Sector Degraded</i> • <i>Microcode Degraded</i> • <i>Power on Self Test Degraded</i> 	Does not execute. Generates Check Condition.
<ul style="list-style-type: none"> • <i>Format Degraded</i> • <i>Reassign Degraded</i> 	Executes.
	Success: Reports Good status.
	Failure: Generates Check Condition.

All Other commands	
Degraded Mode	Description
<ul style="list-style-type: none"> • <i>Motor Stop Degraded</i> • <i>Configuration Sector Degraded</i> • <i>Microcode Degraded</i> 	Does not execute. Generates Check Condition.
<ul style="list-style-type: none"> • <i>Power on Self Test Degraded</i> • <i>Format Degraded</i> • <i>Reassign Degraded</i> 	Executes.
	Success: Reports Good status.
	Failure: Generates Check Condition.

Degraded Mode affects the operation of the automatic rewrite/reassignment function and various internal Target idle time functions as shown in the following tables:

Automatic Rewrite/Reassignment function	
Degraded Mode	Description
<ul style="list-style-type: none"> • <i>Motor Stop Degraded</i> • <i>Configuration Sector Degraded</i> • <i>Microcode Degraded</i> • <i>Power on Self Test Degraded</i> • <i>Format Degraded</i> • <i>Reassign Degraded</i> 	Does not execute.

Update of Performance Counter Data in Reserved Area and Error Logging function	
Degraded Mode	Description
<ul style="list-style-type: none"> • <i>Motor Stop Degraded</i> • <i>Configuration Sector Degraded</i> • <i>Microcode Degraded</i> • <i>Power on Self Test Degraded</i> 	Does not execute.
<ul style="list-style-type: none"> • <i>Format Degraded</i> • <i>Reassign Degraded</i> 	Executes.

Disk Sweep function	
Degraded Mode	Description
<i>Motor Stop Degraded</i>	Does not execute.
<ul style="list-style-type: none"> • <i>Configuration Sector Degraded</i> • <i>Microcode Degraded</i> • <i>Power on Self Test Degraded</i> • <i>Format Degraded</i> • <i>Reassign Degraded</i> 	Executes.

4.1.9.4 Exiting Degraded Mode

There are one or more actions that cause the Target to attempt to exit each Degraded Mode. See Appendix C, “Recommended Initiator Error Recovery Procedures” on page 279 for a description of the recommended Initiator action for each Degraded Mode condition.

The following is a list of the actions and conditions that cause the Target to attempt to exit various Degraded Modes:

- The Target is reset by a Power-On reset or Self Initiated Reset, and the function to automatically start the spindle motor is enabled via the Auto Start jumper (see product Functional Specification).

When this occurs, the Target executes the start-up sequence. (see 4.18, “Bring-Up Sequence” on page 243). The Target attempts to clear the following Degraded Mode conditions:

- *Motor Stop Degraded*
- *Configuration Sector Degraded*
- *Microcode Degraded*
- *Power on Self Test Degraded*
- *Reassign Degraded*

- The Target is reset by a SCSI Bus reset or Bus Device Reset message, and the function to automatically start the spindle motor is enabled via the Auto Start jumper, and the Target has not previously completed the initial attempt to execute the start-up sequence.

When this occurs, the Target executes the start-up sequence. The Target attempts to clear the following Degraded Mode conditions:

- *Motor Stop Degraded*
- *Configuration Sector Degraded*
- *Microcode Degraded*
- *Power on Self Test Degraded*
- *Reassign Degraded*

- A Start Unit command is executed and the Target has not previously completed the initial attempt to execute the start-up sequence.

When this occurs, the Target executes the start-up sequence. The Target attempts to clear the following Degraded Mode conditions:

- *Motor Stop Degraded*
- *Configuration Sector Degraded*
- *Microcode Degraded*
- *Power on Self Test Degraded*
- *Reassign Degraded*

- A Start Unit command is executed and the Target has previously completed the initial attempt to execute the start-up sequence.

When this occurs, the Target only starts the spindle motor and does not execute the complete start-up sequence. The Target attempts to clear the following Degraded Mode conditions:

- *Motor Stop Degraded*

- A Write Buffer command with the Download Microcode or Download Microcode and Save option is executed.

If the Write Buffer command completes successfully, the Target clears the following Degraded Mode conditions:

- *Microcode Degraded*

- A Send Diagnostic command is executed.

If the Send Diagnostic command completes successfully, the Target clears the following Degraded Mode conditions:

- *Power on Self Test Degraded*

- *Reassign Degraded*

- A Format Unit command is executed.

If the Format Unit command completes successfully, the Target clears the following Degraded Mode conditions:

- *Format Degraded*

- *Reassign Degraded*

- A Reassign Blocks command is executed. The LBA specified by the Reassign Blocks command must be for the same LBA that was previously reassigned when the Reassign Degraded Mode was entered. Otherwise, the command is not executed and is ended with Check Condition Status.

If the Reassign Blocks command completes successfully, the Target clears the following Degraded Mode conditions:

- *Reassign Degraded*

4.1.10 Command Processing While Reserved

A logical unit is reserved after successful execution of the Reserve command. Each time a Reserve command is executed successfully, the Target records the SCSI ID of the Initiator that made the reservation and the SCSI ID of the Initiator that is to receive the reservation. This information is needed to determine whether subsequent commands should be permitted or if the *Reservation Conflict Status* should be reported. The Initiator that made the reservation is the Initiator that issued the Reserve command. The Initiator to receive the reservation may be either the same or a different Initiator (third-party reservation).

Note: A third-party reservation (3rdPty bit equal to one) with the Third Party Device ID set equal to the SCSI ID of the Initiator that issued the Reserve command is not distinguishable from a Reserve command with the third party (3rdPty) bit equal to 0. In either case, the Target interprets both the SCSI ID of the Initiator that made the reservation and the Initiator to receive the reservation to be the SCSI ID of the Initiator that issued the Reserve command. In this case, a 3rdPty release is not required, but is allowed.

If the logical unit is reserved when a new command is received, the Target examines the command opcode and the SCSI ID of the issuing Initiator to determine whether a *Reservation Conflict Status* should be returned based on the following rules:

1. If the issuing Initiator is the one that made the reservation and also the one to receive the reservation then:
 - All commands are permitted.
2. If the issuing Initiator is neither the one that made the reservation nor the one to receive the reservation then:
 - A Request Sense or Inquiry command is permitted.
 - A Release command is permitted but is ignored.
 - Any other command results in a *Reservation Conflict Status*.
3. If the issuing Initiator is the one that made the reservation but is not the one to receive the reservation then:
 - An Inquiry, Request Sense, Reserve, or Release command is permitted.
 - Any other command results in a *Reservation Conflict Status*.
4. If the issuing Initiator is not the one that made the reservation but is the one to receive the reservation then:
 - A Reserve command results in a *Reservation Conflict Status*.
 - A Release command is permitted but is ignored.
 - Any other command is permitted.

If a *Reservation Conflict Status* is not reported and the command is permitted, then the Target checks the next highest priority internal condition to determine whether execution is allowed. See 4.1.1, “Priority of SCSI Status Byte Reporting” on page 197 for more information.

4.2 Priority Commands

Certain SCSI commands always execute without returning a *Busy Status*, *Reservation Conflict Status*, or *Queue Full Status* in response to the command. These commands are:

- Inquiry
- Request Sense

These commands do not disconnect from the SCSI bus prior to completion (except if a TTD message is received with the command. See 3.1.16, “Target Transfer Disable (13h)” on page 172). They are executed prior to attempting to complete the execution of any other pending command that has disconnected from the SCSI bus. Therefore, a second priority command cannot be received during the execution of a priority command.

These commands are never queued whether or not the command is sent with a queue tag. However, the rules for an Incorrect Initiator Connection still apply to priority commands. (see 4.1.3, “Incorrect Initiator Connection” on page 199)

4.3 Command Queuing

The Target supports both Tagged and Untagged Queuing. An Initiator can use either Tagged or Untagged Queuing but cannot use both at the same time. Both tagged I/O processes and untagged I/O processes can coexist in the command queue at the same time, provided they are associated with different Initiators.

The command queue is allocated on a First-In First-Out (FIFO) basis. See 4.3.2, “Tagged Queuing” on page 222 for exceptions to the FIFO execution order.

Command Queuing is enabled and disabled using the DQue bit in Mode Select page 0Ah.

The following commands are never queued.

- Priority Commands. (i.e. Request Sense and Inquiry).
- Commands linked to previous commands. These are defined to be part of a single I/O process. (Linked commands are always executed immediately following the previous command from the same Initiator. No other Initiator's commands are allowed to be executed between two linked commands.)
- Commands for which disconnection is not allowed. (These may result in a *Busy Status*.)
- Commands in which a SCSI bus error occurred between selection and first disconnection following the receipt of the CDB.
- Commands for an invalid Logical Unit Number.
- Commands which cause an OVERLAPPED COMMANDS ATTEMPTED error. (see 4.1.3, “Incorrect Initiator Connection” on page 199)

In the above listed situations, the command queue is bypassed and the received command becomes an active I/O process immediately. If one of the above situations occurs when there are queued I/O processes, those queued I/O processes are preserved in the command queue in the order they were received.

At the completion of an active I/O process, the queued I/O process at the head of the queue is removed from the queue and becomes an active I/O process. (See 4.3.6, “Termination of I/O processes” on page 224 for the circumstances in which I/O processes can be removed from the queue without executing.)

4.3.1 Untagged Queuing

The Target supports queuing one I/O process from each SCSI Initiator. Untagged I/O processes are treated by the Target as though they were received with Simple Queue Tag messages for purposes of queuing.

Note: There is no guarantee that I/O processes are executed in the order they were received in a multiple initiator environment. Reserve and Release commands must be used to temporarily “lock out” other Initiators if any restrictions apply to the order of command processing in a multiple initiator environment. The Queue Algorithm Modifier parameter value of zero (restricted re-ordering) in Mode Select page 0Ah, only applies to commands from the same Initiator tagged with Simple Queue Tag message.

4.3.2 Tagged Queuing

The Target supports queuing multiple commands from one Initiator if Tagged Queuing is enable.

Initiators may add commands to the queue or delete commands from the queue. When a command is added to the queue, the Initiator may specify the command is to be execute next, in the order received, or allow the the Target to determine the order of execution. The target reordering of commands is controlled by the Mode Select Page 0Ah parameter QMOD. See 1.6.9, “Page 0Ah - Control Mode Parameters” on page 105 for more information.

Commands received with *Head of Queue* tags are executed Last-In First-Out (LIFO). (See 3.1.17, “Queue Tag Messages (20h, 21h, 22h)” on page 173 for more details concerning *Head of Queue* tags.)

When a command terminates with *Check Condition Status*, commands in the queue for that Initiator are not executed until a command is received by that Initiator. Execution of commands in the queue from other Initiators is not affected. See 4.3.5, “Effects of errors on Command Queuing” on page 223.

The Target can queue up to 32 I/O processes. The value of the Disable Queuing (DQue) bit determine how many commands an Initiator may queue.

When Tagged Queuing (DQue = 1) is disable, each Initiator may queued one command. An initiator with an active I/O process is not allowed to queue any commands.

When Tagged Queuing (DQue = 0) is enabled, the Target reserves 2 slots in the command queue for each Initiator the Target has received an I/O process from, once 2 slots become available for that Initiator. This prevents one Initiator from locking out other Initiators. Queue slot reservations are lost when the Target powers down.

The remaining queue slots are shared among all Initiators. The exact number of shared slots depend on the number of Initiators that have sent I/O processes to the Target. Any of the Initiators may have a queued I/O process in one of these shared slots. A single Initiator could use all the shared queue slots, if no other Initiator has more than 2 queued I/O process in the queue. The number of I/O processes a particular Initiator can queue varies between 2 and 32 I/O processes depending on the number of Initiators that have sent I/O process to the target.

4.3.3 Queue Full

When Tagged Queuing is enabled (DQue = 0), the Target responds with *Queue Full Status* when

- The command queue is full and all 32 slots are utilized.
- The command queue is not full but all of the available slots not reserved for use by another initiator are utilized.
- A Format Unit command has been queued but has not yet been executed.
- A Start Unit command has been queued but has not yet been executed.

4.3.4 Rules for Queuing commands

For a description of the rules for queuing commands, see 4.1.4, “Command Processing During Execution of Active I/O Process” on page 200.

4.3.5 Effects of errors on Command Queuing

When an I/O process ends with *Check Condition Status*, the Target builds sense for the Initiator associated with the I/O process which ended with *Check Condition Status*. When an Initiator has sense pending, all queued I/O processes associated with that Initiator that were in the command queue prior to the connection in which the *Check Condition Status* was sent, are held in the queue until the sense data is cleared. The SCSI operations of active I/O processes for that Initiator are suspended until the sense data is cleared. After the pending sense data is cleared, normal execution and dequeuing resumes. This handling of error conditions for Tagged Queuing, corresponds to $QErr = 0$ in Mode Select page 0Ah.

Note: When the queue operation regarding queued I/O processes from other Initiators is not affected, I/O processes may be executed in a different order than they were received with respect to multiple Initiators. See 4.3.1, “Untagged Queuing” on page 221 for more information.

When the Target returns *Check Condition Status*:

- Execution of SCSI operations for active I/O processes of the affected Initiator are suspended until pending sense data is cleared.
Note: the *affected Initiator* is the Initiator which received the *Check Condition Status*.
- Dequeuing is suspended for the affected Initiator until the pending sense data is cleared.
- Dequeuing of queued I/O processes from unaffected Initiators is not suspended, unless execution of SCSI operations for an active I/O process are suspended. In that case, dequeuing of queued I/O processes for all Initiators is suspended.
- Subsequent commands from the affected Initiator clear sense and restore normal queue operation for that Initiator.
 - A REQUEST SENSE command from the affected Initiator bypasses the queue as described in 4.2, “Priority Commands” on page 220, executes immediately, reports and clears the pending sense. A REQUEST SENSE command from the affected Initiator cannot cause an Incorrect Initiator Connection when sense is pending for that Initiator.
 - A command other than REQUEST SENSE from the affected Initiator will clear the pending sense and then be handled according to the protocol described in 4.1, “SCSI Protocol” on page 197.
- It is possible for queued I/O processes to not be executed in the order expected because some Initiators have dequeuing suspended while others do not.
- Relative execution order of all queued I/O processes for the affected Initiator is preserved.
- Relative execution order of all queued I/O processes for all unaffected Initiators is preserved.
- Enqueuing operation is not affected by pending sense.

4.3.6 Termination of I/O processes

I/O processes can be terminated in a number of ways:

- An I/O process ends normally either by being executed by the Target or by encountering an error.
- The current I/O process for a given Initiator is terminated by an *Abort Tag Message*.
- All I/O processes for a given Initiator on the specified logical unit are terminated by an *Abort Message*.
- All I/O processes for a given Initiator on the specified logical unit are terminated by an **Overlapped Commands Attempted** error. See 4.1.3, “Incorrect Initiator Connection” on page 199 for details of this error condition.
- All I/O processes from all Initiators on the specified logical unit are terminated by a *Clear Queue Message*
- All I/O processes from all Initiators are terminated by a *SCSI BUS RESET* or a *BUS DEVICE RESET MESSAGE*.

4.4 Concurrent Command Processing

Concurrent processing is when multiple I/O processes are active (not queued) on the same logical unit. The Target supports multiple active I/O processes executing on the same logical unit. The Initiator becomes aware an I/O process is active when the Data phase (Data In or Data Out) portion of that I/O process has started. The Initiator becomes aware multiple I/O processes are active when the Target has initiated the Data phase of another I/O process on the same logical unit as the first I/O process, before the first I/O process has completed the Status phase.

Two non-priority I/O processes are allowed to execute concurrently on the same logical unit. Priority commands are always allowed to execute concurrently regardless of the number of active I/O processes.

The following I/O processes are allowed to execute concurrently:

- Priority commands. (See 4.2, “Priority Commands” on page 220).
 - Inquiry
 - Request Sense

The following command is allowed to execute concurrently when the Concurrent Processing Enable (CPE) bit is 1. (See 1.6.2, “Page 0 - Vendor Unique Parameters” on page 75)

- Back to Back write commands.

When an I/O process ends in *Check Condition Status*, other active I/O processes from the same initiator to the same logical unit will not reconnect and complete execution until the sense data has been cleared. (See 4.3.5, “Effects of errors on Command Queuing” on page 223.)

4.4.1 Back to Back Writes

Back to back writes allows multiple write commands which write sequential logical blocks, to be written to the media without losing a motor revolution between the ending of each write command and the beginning of the following write command.

The Target will write back to back under the following conditions:

- Two (or more) write commands (Operation Code 0Ah or Operation Code 2Ah) execute consecutively, without an intervening command.
- The write commands address consecutive logical block ranges. The logical block specified for the second write command is the next logical block following the last logical block to be written by the first write command.
- One logical block of data has been received in the buffer from the second write command in time to allow the media to be written before an additional revolution would be required.
- Concurrent Processing is enabled (CPE = 1) or Write Caching is enabled (WCE = 1, FUA = 0).

When the Target is required to write the data to the media before sending Status (writes not cached), the write commands execute concurrently. Following the completion of the Data Out phase and before the Status phase of the first write command, the Data Out phase of the second write command begins. When the first write command has completed writing the data to the media, and the second write command is disconnected, the first write command returns Status. The Target continues with writing data to the media for the second write command without losing a motor revolution.

When the Target is caching writes, *Good Status* is returned before writing all the data to the media. (See description of Write Cache Enable (WCE) bit in 1.6.8, “Page 8h - Caching Parameters” on page 102 and 4.9.4, “Write Cache” on page 235 for more information.) Execution of the second write command begins after the first write command returns status, but before the first write command has completed writing data to the media. When the Target completes writing data to the media for the first write command, data is written to the media for the second write command without losing a motor revolution.

Status for the first write command is always returned before Status is returned for the second write command. If the first write command returns *Check Condition Status* and the second write command is from the same initiator, execution of SCSI operations for the second write command are suspended. The second write command will resume execution when the pending sense data is cleared. Dequeuing and execution of queued commands for all initiators on the logical unit with the pending sense data are suspended until the pending sense data is cleared. (See 4.3.5, “Effects of errors on Command Queuing” on page 223.)

4.5 Motor Synchronization

Motor synchronization is controlled by the MODE SELECT command. See 1.6.6, “Page 4h - Rigid Disk Drive Geometry Parameters” on page 97 for a complete description of the command's role regarding Motor Synchronization.

If changing from an unsynchronized state to a synchronized state, a Unit Attention condition is generated for all Initiators. The sense key is set to UNIT ATTEN-

TION and the additional sense code/qualifier is set to SPINDLES SYNCHRONIZED.

If changing from a synchronized state to an unsynchronized state, a Unit Attention condition is also generated for all Initiators. The sense key is set to UNIT ATTENTION and the additional sense code/qualifier is set to SPINDLES NOT SYNCHRONIZED.

If the Target fails to achieve synchronization, a Unit Attention condition is generated for all Initiators. The sense key is set to UNIT ATTENTION and the additional sense code/qualifier is set to SPINDLES NOT SYNCHRONIZED.

See 4.1.5, “Unit Attention Condition” on page 202 for more information on Unit Attentions.

The actual state of synchronization can be altered by three different types of events -

1. Any event that attempts to start the spindle motor when the RPL field has a value other than 00b.

If an Initiator wishes to place the Drive into a synchronized mode other than the one that it is currently in, it must ensure that the current RPL field has the desired value and the proper signals are present on the Spindle Synchronization Cable (if required) before that attempt is made. For example, if an Initiator changes a Drive spindle synchronization mode from No Sync to Master Sync Control, it must ensure that another Drive is driving the Slave Sync line with a proper signal and that no other Drive is driving the Master Sync line before that attempt is made.

2. An error condition that causes the motor to fall out of synchronization subsequent to achieving synchronization is reported in two possible ways.
 - If the loss of synchronization is detected when an I/O process is not executing, the Target creates a unit attention condition for all initiators. The sense key is set to UNIT ATTENTION, the additional sense code/qualifier to SPINDLES NOT SYNCHRONIZED.
 - If detected by an I/O process, the first I/O process to detect the synchronization error attempts to complete execution of the I/O process. The Target returns *Check Condition Status* for this I/O process. The sense key is set to RECOVERED ERROR if the Target is able to successfully complete the I/O process. The additional sense code/qualifier is set to SPINDLES NOT SYNCHRONIZED. The Target then generates a Unit Attention condition for all other Initiators. The sense key is set to UNIT ATTENTION and the additional sense code/qualifier is set to SPINDLES NOT SYNCHRONIZED. If in addition to the loss of synchronization, another error occurs, the sense data will be for the additional error and the Unit Attention will be set for all initiators.
3. When the value of the RPL field in Page 4 of the MODE SELECT command has changed, the spindle synchronization is updated.

The value of the RPL field Page 4 of the MODE SELECT command also affects the way the FORMAT UNIT command operates. The Target alters the method of track and cylinder skewing depending on whether the RPL field is set to synchronized or unsynchronized operation. When the motor synchronization mode is changed a FORMAT UNIT command should be issued to change the track and cylinder skewing. The value of the RPL field in Page 4 of the MODE SELECT

command *that is present when a FORMAT UNIT is initiated* is the value that determines the skewing method used.

Note: If the drive is operated in a synchronized mode but was formatted with the RPL field set to unsynchronized mode, *the Drive is effectively not synchronized* even though the spindles are synchronized.

In summary, changing the motor synchronization mode is done as follows:

- Issue a MODE SELECT command with the RPL field in Page 4 - Rigid Disk Drive Geometry Page set to the desired value.
- Reformat the Drive using the FORMAT UNIT command.

4.6 Error Logs

The target maintains error logs in RAM and in the reserved area for use in development and Automatic/Recommend Reassignment. When an error occurs, it is entered into the logs maintained in RAM and is analyzed for Automatic/Recommend Reassignment. The contents of these RAM logs are copied to the reserved area during idle time to prevent impacts to performance. If insufficient idle time is available to copy the log contents to the reserved area and the RAM logs are full, the copying will occur following the completion of the command on which the last error occurred. When the log contents are copied at the end of the command, the target will disconnect from the SCSI bus, if allowed, and then reconnect before ending the command.

4.7 Automatic Rewrite/Reallocate - Recommend Rewrite/Reassign

The target supports Auto and Recommend Reallocate for READ, WRITE, WRITE and VERIFY, VERIFY, and WRITE SAME. (See 1.6, “Mode Select (6)” on page 70 for a description of the bits used to control automatic reallocation.)

Automatic and Recommend Reallocate operate from within the read/write command. When an automatic reallocation occurs, the read or write command takes longer to complete. During this time, the target disconnects from the SCSI bus, if allowed, and reconnects before ending the command.

Following is a description of the target behavior for each setting of ARRE. ARRE settings affects all data errors (No Sector Found, Data Sync Byte Errors and Data ECC Errors.)

- ARRE = 1 - An error site determined to need rewriting or reassignment during a read is automatically rewritten or reallocated at the conclusion of the read and prior to sending ending status. If the site cannot be automatically rewritten or reallocated, then a recommendation for reassignment is given. The site will be automatically rewritten or reallocated only if it can be successfully read.
- ARRE = 0 - An error site determined to need rewriting or reassignment during a read is recommended for rewriting or reassignment at the conclusion of the read.

The setting of the ARRE bit is checked and the target will automatically rewrite/reallocate or recommend rewrite/reassign for the following commands.

- Read(6)
- Read(10)

The target will recommend rewrite/reallocate but will not auto rewrite/reallocate for the following commands.

- Verify
- Verify Portion of Write and Verify

For all other commands the ARRE setting is ignored and the target will not automatically rewrite/reallocate or recommend rewrite/reassign.

Following is a description of the target behavior for each setting of AWRE. AWRE settings affect only No Sector Found errors on writes.

- AWRE = 1 - An error site determined to need reassignment during a write is automatically reallocated at the conclusion of the write and prior to sending ending status. If the site cannot be automatically reallocated, then a recommendation for reassignment is given. The site is automatically reallocated only if the write recovery succeeded and the site can then be read.
- AWRE = 0 - An error site determined to need reassignment during a write will be recommended for reassignment at the conclusion of the write.

The setting of the AWRE bit is checked and the target will automatically reallocate or recommend reassign for the following commands.

- Write(6)
- Write(10)
- Write Same
- Write portion of Write and Verify

For all other commands the AWRE setting is ignored and the target will not automatically rewrite/reallocate or recommend rewrite/reassign.

Auto/Recommend Reallocate information is communicated via the sense data returned following a command during which a site was determined to need rewriting or reassignment. The LBA returned in the sense data is the LBA that was determined to need rewriting or reassignment. The Sense Key/Code/Qualifier combinations listed below is a list of all possible combinations that are valid for Auto Reallocate/Recommend Reassign.

It is important to note that Auto Reallocate/Recommend Reassign is affected by several Mode Parameters. See the description of the RPF AE bit in the section describing 1.6.2, “Page 0 - Vendor Unique Parameters” on page 75 for information regarding the reporting of soft errors associated with Predictive Failure Analysis functions.

The sense data combinations associated with auto/recommend rewrite/reallocate are listed below.

Table 160. Auto/Recommend Rewrite/Reallocate Sense data combinations.. Sense data combinations for automatic or recommend rewrite or reallocate.			
Key	Code	Qual.	Description
1	0C	01	Recovered Write error - Auto Reallocated.
3	0C	02	Recovered Write error - auto reallocate failed.
1-3	0C	03	Write Error - Recommend Reassign.
3	11	04	Auto reallocate failed due to unrecovered read error.
3	11	0B	Unrecovered read error - Recommend Reassign.
1-3	14	05	Record Not Found - Recommend Reassign.
1	14	06	Record Not Found - data Auto-Reallocated.
1	16	01	Sync Byte Error - data Rewritten.
1	16	02	Sync Byte Error - recommend Rewrite.
1	16	03	Sync Byte Error - data auto-reallocated.
1-3	16	04	Sync Byte Error - Recommend Reassign.
1	17	06	Recovered data without ECC - Auto Reallocated.
1	17	07	Recovered data without ECC - Recommend Reassign.
1	17	08	Recovered data without ECC - Recommend Rewrite.
1	17	09	Recovered data without ECC - Data Rewritten.
1	18	02	Recovered data with ECC - Auto Reallocated.
1	18	05	Recovered data with ECC - Recommend Reassign
1	18	06	Recovered data with ECC - Recommend Rewrite.
1	18	07	Recovered data with ECC - Data Rewritten.

4.8 Predictive Failure Analysis

Predictive Failure Analysis (PFA) is an internal function of the Target. During Idle periods and as a part of Error Recovery, the Target performs a number of functions designed to predict drive failure conditions before they occur. The predictive actions performed by the Target are:

- Error Log Analysis
- Data channel parametric measurement and analysis
- Head flyheight analysis

When one of the predictive functions detects an anomaly and reporting of PFA is enabled by the appropriate Mode Select parameters, the Target will send Check Condition Status following a successful Read or Write command. The sense will indicate a Recovered Error and the sense Code/Qualifier will be ***Predictive Failure Analysis Threshold Reached on Recovered Error***.

The appropriate Mode Select parameters for enabling PFA reporting are shown in the RPPAE description in 1.6.2, “Page 0 - Vendor Unique Parameters” on page 75.

4.9 Segmented Caching

4.9.1 Overview

Segmented Caching divides the data buffer into several smaller buffer segments. Each buffer segment is used as a separate Read / Write / Read-Ahead / Pre-Fetch buffer.

At the start of a command, the target chooses which segment to use and where to start in the segment. The selection of the segment is based on whether or not the desired blocks are currently in the segment, the retention priority, and the relative age of the data now in the segment.

During the execution of a Read command, the target determines whether to transfer all the data directly from the cache segment, or to access the media to retrieve all or part of the requested data. If the media is accessed, the target also chooses how much Read-Ahead is to be done afterward.

4.9.2 Options Supported

- Log Sense Vendor Unique Page 35h: Cache Hit/Miss
 - Cumulative Cache Hits on Reads
 - Cumulative Cache Partial Hits on Reads
 - Cumulative Cache Misses on Reads
- Mode Select Page 0: Vendor Unique Parameters
 - ADC: Adaptive Caching
- Mode Select Page 8: Caching Parameters
 - RCD: Read Cache Disable
 - MF: Multiplication Factor
 - WCE: Write Cache Enable
 - Demand Read Retention Priority
 - Write Retention Priority
 - Disable Pre-Fetch Transfer Length
 - Minimum Pre-Fetch
 - Maximum Pre-Fetch Ceiling
 - Number of Cache Segments
- Pre-Fetch Command
- Read-Ahead for Read commands
- Write Retention for Write and Write Verify commands
- DPO: Disable Page Out option on Read Commands
- FUA: Force Unit Access option on Read Commands
- DPO: Disable Page Out option on Write and Write Verify Commands

See 1.5.11, “Log Sense Page 35h” on page 69, 1.6.8, “Page 8h - Caching Parameters” on page 102, 1.10, “Read (10)” on page 122, and 1.32, “Write (10)” on page 157 for more details on the caching options.

4.9.3 Read-Ahead

The Read-Ahead function consists of reading data into the Target's data buffer that the Initiator has not yet requested. It is a form of anticipatory reading. This function is intended to improve performance for an Initiator that frequently accesses sequential data with successive Read commands.

The Read-Ahead function is controlled by the Mode Select Page 8 Caching parameters (See 1.6.8, “Page 8h - Caching Parameters” on page 102). When the Read-Ahead function is enabled, a Read-Ahead is normally performed following the execution of every Read command. However, if all the data requested by the Read command already resides in a cache segment, then a Read-Ahead is not performed. For this case, the data is transferred directly from the cache segment, and the media is not accessed. If only a portion or none of the data requested by the Read command resides in a cache segment, then the media will be accessed and a Read-Ahead will be performed based on the Mode Select Page 8 Caching parameters and Page 0, ADC bit as follows:

If the RCD (Read Cache Disable) bit from Mode Select Page 8 is on or if the number of requested blocks for the Read command is greater than the Disable Pre-Fetch Transfer Length from Mode Select Page 8, then a Read-Ahead operation is not performed. Otherwise the number of Read-Ahead blocks for the Read-Ahead operation is calculated based on the Mode Select Page 8 Caching parameters as follows:

If the MF (Multiplication Factor) bit in the Mode Select Page 8 is on, the Maximum Pre-Fetch parameter from Mode Select Page 8 is multiplied by the number of requested blocks from the Read command and used as the number of Read-Ahead blocks. If the MF bit is off, the Maximum Pre-Fetch parameter is used as the number of Read-Ahead blocks.

Whether or not a new command received while Read Ahead is executing causes the Read Ahead to be aborted depends upon how much data has already been read ahead and the value of the Minimum Pre-fetch parameter. If the amount of data prefetched (or read ahead) does not meet or exceed the Minimum Pre-Fetch parameter value then the Read Ahead is not aborted. If the amount prefetched does exceed that value, then the Read Ahead may be aborted. (See 1.6.8, “Page 8h - Caching Parameters” on page 102 for more information about Minimum Pre-fetch.)

If ADC (Adaptive Caching) bit in the Mode Select Page 0 is on, the number of Read-Ahead blocks may be reduced if the drive is receiving non-sequential commands.

The number of Read-Ahead blocks is then reduced by any or all of the following factors:

- The number of Read-Ahead blocks is reduced so that it is not larger than the Maximum Pre-Fetch Ceiling parameter from Mode Select Page 8.
- The number of Read-Ahead blocks is reduced so that it is not larger than the size of the data buffer segment. The size of the data buffer segment is determined by the Number of Cache Segments parameter from Mode Select Page 8h and whether or not the ADC bit is set = 1.
- If the Demand Read Retention Priority from Mode Select Page 8 is set to Fh, the number of Read-Ahead blocks is reduced so that Read-Ahead data will not overwrite the Requested Data from the Read command. This occurs if the sum of the number of Read-Ahead blocks and Requested Data blocks is larger than the size of the data buffer segment.
- The number of Read-Ahead blocks is reduced so that the target will not read beyond the end of the media.

The Read-Ahead function works as follows:

- At the conclusion of a Read command, the Target continues to read data into its data buffer. The Target reads the data which immediately follows the data requested by the Initiator in the preceding Read command without missing a revolution of the disk. The Target may or may not overwrite the Read command data in the data buffer which has already been sent to the Initiator. This depends on the size of the number of Read-Ahead blocks for the Read-Ahead operation. The Read-Ahead operation continues until the required number of blocks have been read into the data buffer segment. The Target performs any necessary accesses (single cylinder seek and/or multiple head switches) in order to obtain more sequential data. As each block of data is stored in the data buffer during the read ahead operation, the Target maintains information that identifies the LBAs in the data buffer and their location within the data buffer.
- If an error is encountered during the Read-Ahead operation:
 1. The Target terminates the Read-Ahead operation and does not attempt to recover the data.
 2. The error is not reported to the Initiator for the current Read command. (The error will be reported during the next command if the next command is a Read command that requests the block which encountered the error.)
 3. The blocks which were successfully read prior to the block in error are retained in the cache.
- If a command is received from an Initiator during a Read-Ahead operation, the Target's response varies with the command, as follows:
 - If the command is a priority command (see 4.2, “Priority Commands” on page 220), the Target:
 1. Continues the current Read-Ahead operation.
 2. Executes the priority command.
 - If the command is a Read command whose starting LBA is not in the data buffer segment for the current Read-Ahead operation and is not in any other data buffer segment, or the Force Unit Access (FUA) bit for the Read command is on, the Target:
 1. Terminates the current Read-Ahead operation, assuming Minimum Pre-fetch requirements are met.
 2. Retains the LBAs in the data buffer segment that had been cached during the preceding Read-Ahead operation.
 3. Selects a new data buffer segment. (See 4.9.6, “Segment Selection” on page 236 for more information.)
 4. Executes the Read command.
 5. Starts a new Read-Ahead operation at the conclusion of the Read command.
 - If the command is a Read command (with FUA off) whose starting LBA is not in the data buffer segment for the current Read-Ahead operation, but is in another data buffer segment, the Target:
 1. Terminates the current Read-Ahead operation, assuming Minimum Pre-fetch requirements are met.
 2. Retains the LBAs in the data buffer segment that had been cached during the preceding Read-Ahead operation.
 3. Selects the data buffer segment which contains the most data requested by the current Read command. (See 4.9.6, “Segment Selection” on page 236 for more information.)

4. The target performs the following operations if the selected data buffer segment contains only a portion or none of the requested data:
 - a. Starts a new Read operation to read the required amount of data from the disk for the current Read command and the next Read-Ahead operation.
 - b. Executes the Read command by transferring the LBAs in the selected data buffer segment that had been cached during a previous Read, Read-Ahead, Pre-Fetch, Write, or Write Verify operation.
 - c. Continues with the new Read-Ahead operation at the conclusion of the Read command.
 5. The target performs the following operations if the selected data buffer segment contains all of the requested data:
 - a. Transfers the requested data from the data buffer segment.
 - b. Does not access the media and does not start a Read-Ahead operation.
- If the command is a Read command whose starting LBA is in the data buffer segment for the current Read-Ahead operation and FUA is off, the Target:
 1. Updates the current Read-Ahead operation to read the required amount of data from the disk for the current Read command and the next Read-Ahead operation.
 2. Executes the Read command by transferring the LBAs in the data buffer segment that had been cached during the preceding Read or Read-Ahead operation.
 3. Continues with the new Read-Ahead operation at the conclusion of the Read command.
 - If any other command is received, the Target:
 1. Terminates the current Read-Ahead operation, assuming Minimum Pre-fetch requirements are met.
 2. Retains the LBAs in the data buffer segment that had been cached during the preceding Read-Ahead operation.
 3. Executes the command.

Note: If the command is a media access command that requires use of the data buffer, a new data buffer segment is selected. (See 4.9.6, “Segment Selection” on page 236 for more information.)
 - If a command is received from an Initiator after a previous Read-Ahead operation has completed, the Target's response varies with the command as follows:
 - If the command is a priority command see also 4.2, “Priority Commands” on page 220 the Target:
 1. Preserves the LBAs in the data buffer that had been cached during the preceding Read-Ahead operation.
 2. Executes the priority command.
 - If the command is a Read command whose starting LBA is not in any data buffer segment, or the Force Unit Access (FUA) bit for the Read command is on, the Target:

1. Retains the LBAs in the data buffer segment that had been cached during the preceding Read-Ahead operation.
 2. Selects a new data buffer segment. (See 4.9.6, “Segment Selection” on page 236 for more information.)
 3. Executes the Read command.
 4. Starts a new Read-Ahead operation at the conclusion of the Read command.
- If the command is a Read command whose starting LBA is in the data buffer (any data buffer segment) and FUA is off, the Target:
 1. Retains the LBAs in the data buffer segment that had been cached during the preceding Read-Ahead operation.
 2. Selects the data buffer segment which contains the most data requested by the current Read command. (See 4.9.6, “Segment Selection” on page 236 for more information.)
 3. The target performs the following operations if the selected data buffer segment contains only a portion or none of the requested data:
 - a. Starts a new read operation to read the required amount of data from the disk for the current Read command and the next Read-Ahead operation.
 - b. Executes the Read command by transferring the LBAs in the selected data buffer segment that had been cached during a previous Read, Read-Ahead, Pre-Fetch, Write, or Write Verify operation.
 - c. Continues with the new Read-Ahead operation at the conclusion of the Read command.
 4. The target performs the following operations if the selected data buffer segment contains all of the requested data:
 - a. Transfers the requested data from the data buffer segment.
 - b. Does not access the media and does not start a Read-Ahead operation.
 - If any other command is received, the Target:
 1. Retains the LBAs in the data buffer segment that had been cached during the preceding Read-Ahead operation.
 2. Executes the command.

Note: If the command is a media access command that requires use of the data buffer, a new data buffer segment is selected. (See 4.9.6, “Segment Selection” on page 236 for more information.)

4.9.4 Write Cache

When the drive's Read Cache is enabled ($RCD = 0$) and the Mode Parameter $WCE = 0$, a write-through caching algorithm is employed for data transferred as a result of a write command. This means that the Command Complete message is not returned from the Target to the Initiator until the requested data is successfully stored on the magnetic media. And the data is cached following the completion of the write command. This data resides in a cache segment such that subsequent read commands that access the same LBAs can get cache hits if that data is not overwritten with other LBAs from intervening requests. See the following sections on segment selection and data retention/prioritization for more details.

When the drive's Read Cache is disabled ($RCD = 1$) and the Mode Parameter $WCE = 0$, write data is not cached following the completion of the requested write command. As is the case with the write-through cache algorithm, command complete is not returned until the requested data is successfully written to the magnetic media.

When $WCE = 1$, a write-back caching algorithm is employed for data transferred as a result of a write command. This means that command complete is returned from the Target to the Initiator before requested data is successfully stored on the magnetic media. The data is cached following the completion of the write command for use in possible cache hits for subsequent read commands if $RCD = 0$.

See 4.4.1, "Back to Back Writes" on page 225 for more particular usage information.

4.9.5 Synchronize Cache on SCSI Reset

Write data stored in the cache as a result of a write command, when $WCE = 1$, that has not been written to the media when a SCSI Reset is received is synchronized/destaged as part of the Reset processing. Thus coherence between what a system believes the drive has written to the magnetic media and what it actually has written is maintained across SCSI Resets.

4.9.6 Segment Selection

If the RCD (Read Cache Disable) bit in the Mode Select Page 8 is off, a data buffer segment must be selected before any operation that reads or writes the media can be started.

1. If the operation is one of the following:

- Read Command with the FUA bit off
- Pre-Fetch Command

The Cache is scanned to see if the start of the Requested Data is already in any of the segments. If the data is in more than one segment, and Read Ahead is enabled, the segment associated with the Read Ahead is selected. If Read Ahead is disabled the segment selected will be the segment with the most available data after the start of the Requested Data.

2. If the operation is one of the following:

- Verify Command with the BytChk bit on
- Write Command
- Write and Verify Command
- Write Long
- Write Same

The Cache is scanned to see if the Requested Data is already in any of them. All data within the range of the Requested Data located in segments that are not selected is invalidated.

3. If the command is one of the following:

- Mode Select Command with the Save Parameter bit on
- Pre-Fetch Command and the Start of the Requested Data is not in the cache
- Read Command and the Start of the Requested Data is not in the cache
- Read Command with the FUA bit on
- Read Long Command

- Skip Read/Write Command
- Verify Command with the BytChk bit on
- Write Command
- Write and Verify Command
- Write Long Command
- Write Same Command

The following algorithm is used to select the segment to use:

- a. An Empty segment is chosen.
- b. If there are no Empty segments, the oldest Low Priority segment is chosen.
- c. If there are no Low Priority segments, the oldest Middle Priority segment is chosen.
- d. If there are no Middle Priority segments, the oldest High Priority segment is chosen.

Occasionally, the Drive requires a segment to perform some idle time function. When this happens, the preceding algorithm is used to select a segment.

4.9.7 Segment Prioritization

Initially, all data buffer segments are empty. When a segment is used, it is given a new priority level based on the type of command being executed and the Retention Priorities set in Mode Select Page 8 by the following algorithm:

1. If the command is one of the following, the segment is marked empty after the command completes:
 - Mode Select Command with the Save Parameter bit on
 - Skip Read/Write Command
 - Read Long Command
 - Verify Command with the BytChk bit on
 - Write Long Command
 - Write Same Command
2. If the command is one of the following, all segments are marked empty:
 - Format Unit Command
 - Mode Select Command to Page 8 or Vendor Unique Page 0
 - Reassign Block Command
 - Send Diagnostic Command
 - Write Buffer Command
 - Read Defect Data (10) Command
 - Read Defect Data (12) Command
3. If the command is a Pre-Fetch, the segment is assigned Middle Priority.
4. If the command is a Write, or Write and Verify and:
 - a. The DPO bit is on, the segment is assigned Lowest Priority.
 - b. The DPO bit is off and the Write Retention Priority is:
 - 0** The segment is assigned Middle Priority.
 - 1** The segment is assigned Low Priority.
 - Fh** The segment is assigned High Priority.
5. If the command is a Read and Read-Ahead will occur and:
 - a. The DPO bit is on, the segment is assigned Middle Priority.
 - b. The DPO bit is off and the Demand Read Retention Priority is:
 - 0** The segment is assigned Middle Priority.
 - 1** The segment is assigned Middle Priority.

Fh The segment is assigned High Priority.

6. If the command is a Read and Read-Ahead will not occur and:

a. The DPO bit is on, the segment is assigned Lowest Priority.

b. The DPO bit is off and the Demand Read Retention Priority is:

0 The segment is assigned Middle Priority.

1 The segment is assigned Low Priority.

Fh The segment is assigned High Priority.

Segments chosen for idle time functions are marked empty. All segments are marked empty if any of the following events occur:

- Automatic Block Reassign
- Bus Device Reset Message
- Power on Reset
- Self Initiated Reset
- SCSI Bus Reset

4.10 Reselection Timeout

A reselection timeout error occurs when the target attempts to reselect an initiator and the initiator does not respond within a Selection Timeout delay (250 mSec). If this occurs, the target releases the SCSI bus to the Bus Free phase (following the reselection timeout procedure) and then retries the reselection one more time. If a second reselection timeout error occurs, the target releases the SCSI bus to the Bus Free phase (following the reselection timeout procedure) and does not attempt to reselect the initiator again. This error condition causes the target to generate sense data with a Sense key of Aborted Command and an Additional Sense code of Select/Reselect failure (45h). If the second reselection is successful, command execution is resumed and no sense data is generated.

4.11 Single Initiator Selection

For single initiator systems, it is not an error to have only the target ID bit present during selection. Disconnection is not allowed for Single Initiator Selection with only one ID bit present during selection. The initiator must not send an Identify message with the disconnect permission bit (6) set.

4.12 Non-arbitrating Systems

The target cannot detect whether other SCSI devices on the SCSI bus use arbitration prior to selection. As a consequence, the target allows disconnect permission to be enabled by the Identify message independent of the initiators use of arbitration prior to selection. A non-arbitrating initiator must ensure that disconnect permission in the Identify message is disabled (bit 6=0) for proper operation.

4.13 Selection without ATN

If the target is selected without the ATN signal active, no Identify message is received from the initiator. In this case, the LUN is identified from the CDB and disconnect permission is disabled. The target does not perform any phase retries. The target still responds to a subsequent attention condition. However, the LUN is not considered to be known if a fatal error is detected during the Command phase. That is, a Command phase parity error or a fatal message error in response to attention condition during Command phase is handled as a Bus Free error with no sense data. The target also allows the use of linked commands if selected without ATN. The target does not initiate synchronous or wide data transfer negotiation if selected without ATN.

Phase retries and target initiated negotiations may be allowed if a subsequent Identify message is received.

4.14 Multiple Initiator Systems

This section describes how the target supports Multiple initiator systems.

4.14.1 Initiator Sense Data

A separate sense data area is reserved for each initiator. Each initiator's sense data is maintained independent of commands from other initiators. This allows a command from one initiator to complete with a Check Condition status and generated sense data, without being affected by a subsequent command from a different initiator. There is no requirement for the first initiator to send a Request Sense command to retrieve the sense data prior to target execution of a command from a different initiator.

4.14.2 Initiator Mode Select/Mode Sense Parameters

A single shared copy of the Mode Select/Mode Sense parameters is maintained by the target. This includes both the current and saved parameters. If a Mode Select command is executed, which updates the current parameters, a Unit Attention condition is generated for all initiators except the one that issued the Mode Select command. See 4.1.5, “Unit Attention Condition” on page 202 for more information.

4.14.3 Initiator Data Transfer Mode Parameters

A separate data transfer mode parameters area is reserved for each Initiator. Each initiator's data transfer mode (synchronous transfer period, REQ/ACK offset, and data transfer width) is maintained independent of Synchronous Data Transfer Request messages and Wide Data Transfer Request messages from other initiators. This allows multiple initiators to send commands to the target with different data transfer modes without the need to renegotiate the synchronous data transfer mode or the wide data transfer mode during each command.

4.15 Options Jumper Block

The Drive provides an Options Jumper Block which allows the drive to be customized using jumpers instead of software settings. Refer to the product Functional Specification for detailed information on the location and function of these jumpers. Functions listed below are controlled via the options jumper block.

Auto Start

Spindle Synchronization

LED output

Write Protect

Disabling Target Initiated Synchronous Negotiation

Disabling Unit Attentions

Disabling SCSI Parity

Auto Start Delay

4.16 LED Pin

The Drive provides a LED pin which allows the integrator to attach an external LED to the drive, and use this pin output to control the LED. The MODE SELECT command allows a selection of various Drive 'conditions' to be reflected at the pin output. See 1.6.2, "Page 0 - Vendor Unique Parameters" on page 75 for information regarding the CMDAC and LED Mode fields. The "Jumper Settings" section of the *product Functional Specification* shows the location of the LED pin.

4.17 Reset

The Reset condition is used to clear all SCSI devices from the bus. This condition takes precedence over all other phases and conditions. After a reset condition is detected and the reset actions completed, the target returns to a 'SCSI bus enabled' state that allows the target to accept SCSI commands.

This device uses the Hard reset option as defined in the SCSI-2 standard.

4.17.1 Reset Sources

There are four sources of resets detected by the target:

Reset Name	Reset Source
Power-On reset	This is the signal generated by the hardware at initial power-on.
Self-Initiated reset	This is a software-generated reset that occurs when a catastrophic error is detected by the microcode (for example, microcode sanity error).
SCSI Bus reset	This is a reset generated when the SCSI bus control line RST goes active.
SCSI Bus Device Reset message	This is the reset generated by the SCSI Bus Device Reset Message (0Ch).

4.17.2 Reset Actions

The action taken by the Drive following a reset is dependent on the source of the reset.

4.17.2.1 Power-On reset and Self-Initiated reset

These two reset conditions cause the following to be performed in the order shown.

1. A power-up sequence
2. A start-up sequence is necessary (see 4.18, "Bring-Up Sequence" on page 243) to put the Drive in a ready state

4.17.2.2 SCSI Bus reset and SCSI Bus Device Reset message

These two reset conditions cause the following to be performed.

- If reset goes active while the power-up sequence is in progress, the power-up sequence is started over.
- If the Auto Start pin is grounded and a start-up sequence has not yet completed, a start-up sequence will be re-attempted from the beginning.
Note: The power-up sequence, having already completed, is not rerun.
- If reset occurs while a physical sector is being written, the write operation is disabled after the current physical sector is written. Data is not lost as long as power stays valid until the physical sector being written is completed.

4.18 Bring-Up Sequence

Two sequences of events must occur after power is applied to the Drive (POR) before the Drive becomes ready. (See the command description of 1.29, “Test Unit Ready” on page 153 for the description of 'ready'.) A power-up sequence and a start-up sequence are required. The following is a chronological list of actions taken by the Target after POR in order to be ready.

The power-up sequence attempts to:

1. Perform BATS1 testing (see 4.19.1, “BATS1 Tests” on page 244)
2. Enable SCSI Bus

(The Target can only respond to SCSI commands after the power-up sequence is complete.)

Note: Refer to the *product Functional Specification* for information relating to execution time of the power-up sequence.

If the auto start motor is not enabled by the Auto Start pin being grounded, a Start/Stop Unit command is required to continue bring-up beyond this point. Else bring-up halts at this point until a Start/Stop Unit command is received.

The start-up sequence attempts to:

1. Start the spindle motor. Set ***Motor Stop Degraded*** if unable to spin up.
2. Read the Configuration Record from the Reserved Area (see 4.20, “Reserved Area” on page 245) Set ***Configuration Sector Degraded*** if the configuration record cannot be read.
3. Read the RAM Microcode from the Reserved Area (Microcode upload)
4. Electronics/Disk Enclosure (DE) Compatibility Test
5. Read the remaining configuration information from the Reserved Area
6. Perform BATS2 testing (see 4.19.2, “BATS2 Tests” on page 244)
7. Set the spindle motor synchronization state (see 4.5, “Motor Synchronization” on page 225)
8. Check for an interrupted Format Unit operation.
9. Resume a checkpointed Reassign Blocks command or automatic reallocation (See 4.1.9.4, “Exiting Degraded Mode” on page 217)

4.19 Basic Assurance Tests (BATS)

Basic Assurance Tests (BATS) are a series of tests performed by the target to internally test the controller and Drive hardware. The BATS are broken into two functional groups, BATS1 and BATS2. The BATS1 tests are run during the power-up sequence. The BATS2 tests are run during the start-up sequence.

4.19.1 BATS1 Tests

BATS1 consists of the following tests:

- Microprocessor Functional Test
- Controller Hardware Test
- ROM Checksum Test
- Microprocessor RAM Test

4.19.2 BATS2 Tests

BATS2 consists of the following tests:

- Data Buffer Test
- Seek Test
- Head Offset Test
- Read Test (all heads)
- Write Test (all heads)
- Cyclic Redundancy Code (CRC) Test
- Error Correction Code (ECC) Test
- Longitudinal Redundancy Code (LRC) Test

4.20 Reserved Area

The target maintains a Reserved Area on the disk. This area is never used for customer data. An initiator has no direct access to this area.

The Reserved Area is used as follows:

- Power-on Self-Test

The Reserved Area is used during the self-test to verify that the Drive can read and write with each of its heads.

- Flags

A set of flags is used by the Drive to checkpoint critical operations. For example, the flags are used to determine whether the Drive lost power during a format or relocate physical sector operation. Operations such as these must be completed before normal processing can resume.

- Manufacturing SAT map (PList)

The map of disk defect sites created at manufacturing time, SAT (Surface Analysis Test), is contained in the Reserved Area. This map is used during format operations but is never altered.

- Grown defect map (GList)

The Reserved Area also contains a grown defect map. The GList map is empty at time of manufacture. Defect locations defined by the initiator with the Reassign Blocks, Format Unit command or Automatic Reallocation are maintained in the GList.

Note: The Format Unit command may purge, replace, preserve or add to the GList at the initiator's option.

- Error Logs

The Error Logs are used to maintain information for Predictive Failure Analysis functions such as Automatic/Recommend Block Rewrite/Reallocation.

- RAM Microcode

The Drive's RAM microcode load is contained in the Reserved Area.

- Configuration Information

- Configuration Record (Configuration data and Controller data)
- Inquiry (VPD) data
- Mode Select/Sense saved parameters

- Scratch areas for Reassignment

- Predictive Failure Test Areas

d

Appendix A. SCSI Sense Data Format

Following is the format of data returned by the Target in response to the Request Sense command.

Table 161. Format of Sense Data								
Byte	BIT							
	7	6	5	4	3	2	1	0
0	Valid	Error Code (70h or 71h)						
1	Reserved = 0							
2	RSVD = 0	ILI	RSVD = 0	Sense Key				
3	(MSB) Information (LSB)							
4								
5								
6								
7	Additional Sense Length = 18h							
8	(MSB) Command Specific Information (LSB)							
9								
10								
11								
12	Additional Sense Code							
13	Additional Sense Code Qualifier							
14	Field Replaceable Unit							
15	SKSV	Sense-Key Specific Bits						
16	(MSB) Sense-Key Specific Bytes (LSB)							
17								
18 - 19	Reserved = 0							
20 - 21	Unit Error Code							
22 - 23	Reserved = 0							
24 - 29	Physical Error Record (See Description)							
30 - 31	Reserved = 0							

A.1.1 Sense Data Description

Byte 0

Valid

The Valid Bit set to one indicates the Information field contains valid information. The Valid Bit, in conjunction with the ILI bit (byte 2) indicate what is in the Information field and the Physical Error Record field. The Valid Bit set to zero indicates the Information field does not contain valid information.

Error Code

Error Code set to 70h indicates an error for the current command. Error Code set to 71h indicates a deferred error. This indicates that the error is for a previous active LUN condition that returned a **Good** status. Such commands are associated with the use of the Immediate Bit. The Format Unit command is an example of a command that may cause deferred error sense data to be set.

Byte 1

Not supported. Set to zero.

Byte 2

ILI

Incorrect Length Indicator is valid for the Read Long and Write Long commands only. ILI set to one and Valid Bit set to one indicates that the requested logical block length did not match the logical block length of the data on the medium for a Read Long or Write Long command. The Information field contains residue information about the error ILI set to zero indicates there is no incorrect length condition.

Sense Key

SENSE KEY is the SCSI method of classifying sense information for operating system interpretation. Additional detail may be obtained from the additional sense bytes.

0 *No Sense*

There is no sense key information to be reported for the logical unit.

1 *Recovered Error*

The last command completed successfully with recovery action performed by the Target. More detailed information is available in the Additional Sense Code and Additional Sense Code Qualifier.

The contents of the Physical Error Record field (bytes 24 through 29) are valid for this sense key.

Exception: For errors associated with a Predictive Failure Analysis Threshold Reached, Additional Sense Code/Qualifier (5Dh/00h), the contents of the Physical Error Record field may be invalid.

2 *Not Ready*

The logical unit addressed cannot be addressed. More detailed information is available in the Additional Sense Code and Additional Sense Code Qualifier.

The contents of the Physical Error Record field (bytes 24 through 29) are zero for this sense key.

3 ***Medium Error***

The command terminated with a non-recoverable error condition caused by a flaw in the media or an error in the recorded data. More detailed information is contained in the Additional Sense Code and Additional Sense Code Qualifier. The contents of the Physical Error Record field (bytes 24 through 29) are valid for this sense key.

4 ***Hardware Error***

The Target detected a non-recoverable hardware error while performing a command or during a diagnostic test. More detailed information is contained in the Additional Sense Code and Additional Sense Code Qualifier. The contents of the Physical Error Record field (bytes 24 through 29) are valid for this sense key.

5 ***Illegal Request***

There was an illegal parameter in the Command Descriptor Block or additional parameter supplied as data. If the Target detects an invalid parameter in the CDB, then the command is terminated without altering the medium. If an invalid parameter is detected in parameters supplied as data, then the Target may already have altered the medium. The contents of the Physical Error Record field (bytes 24 through 29) are zero with this sense key.

6 ***Unit Attention***

This sense key is reported after an attention causing event.

7 ***Data Protect***

This sense key is reported to a Write type command when the target is in Write Protect Mode.

8 - A Not Used

B ***Aborted Command***

The Target aborted the command. The contents of the Physical Error Record field (bytes 24 through 29) are zero with this sense key.

C - D Not Implemented

E ***Miscompare***

The source data did not match the data read from the medium

F Not Implemented

Byte 3 - 6

Information

- ILI = 1 - Bytes 3 through 6 contain the difference (residue) of the requested length minus the actual length in bytes. Negative values are indicated by two's complement notation.
- ILI = 0 - Bytes 3 through 6 contain the unsigned Logical Block Address associated with the sense key. If the Valid Bit is on, the LBA reported will be within the LBA range of the command as defined in the Command Descriptor Block.

Note: An LBA other than the command LBA may be reported on the Reassign Blocks command.

Byte 7

Additional Sense Length

Byte 7 contains the remaining number of bytes in the sense data. Sense data for this product is always 32 bytes.

Byte 8 - 11

Command Specific Information

If a *Reassign Blocks* command fails, this field contains the first LBA from the defect descriptor block that was not reassigned.

If an *Auto-Reallocation* fails, this field contains the LBA that was not reassigned.

Byte 12

Additional Sense Code

Byte 13

Additional Sense Code Qualifier

Note: In Table 162, the Initiator recovery field is the recommended initiator recovery procedure for each Key/Code/Qualifier combination. The table has the Key/Code/Qualifier Combination with the SCSI description and Recommended Initiator Recovery Procedure, followed by a list of target error conditions which will return that combination.

Note: In Table 162, the Key, Code, and Qualifier fields are all hex values. (i.e. Sense Key E is Eh, Sense Code 0C is 0Ch, etc.)

Table 162 (Page 1 of 19). Valid Sense Key, Code, Qualifier Combinations used by the drive.				
Key	Code	Qual	Description	Initiator Recovery
Sense Key = <i>No Sense</i>				
0	00	00	<i>No Additional Sense Information</i> No error.	NONE
Sense Key = <i>Recovered Error</i>				
1	01	00	<i>No Index/Sector Signal</i> Fake and Extra Index. Write with No Sector Pulses.	C.4.3, "Recovered drive error" on page 285

Table 162 (Page 2 of 19). Valid Sense Key, Code, Qualifier Combinations used by the drive.				
Key	Code	Qual	Description	Initiator Recovery
1	02	00	<p>No Seek Complete</p> <p>Servo error; Seek timeout.</p> <p>Servo error; Recalibrate Breakaway Failed</p> <p>Servo error; Recalibrate State 2 timeout</p> <p>Servo error; Recalibrate State 4 timeout</p> <p>Too many missing Servo IDs detected by Controller/Channel Hardware</p> <p>Servo error; Coarse offtrack</p> <p>Servo error; Recalibrate State A timeout</p> <p>Servo error; 3 Bad Servo ID's</p> <p>Servo error; Recalibrate State B timeout</p>	C.4.3, "Recovered drive error" on page 285
1	03	00	<p>Peripheral Device Write Fault</p> <p>Arm Electronics Not Ready.</p> <p>Arm Electronics error.</p> <p>Sector overrun error.</p> <p>Interface Processor write inhibit error.</p> <p>Microjog Write Inhibit</p> <p>IP Retract Error</p> <p>External Write Inhibit.</p>	C.4.3, "Recovered drive error" on page 285
1	09	00	<p>Track Following Error</p> <p>Servo error; Loss of interrupts from the Controller/Channel Hardware.</p> <p>Servo error; Settle timeout.</p> <p>Servo error; Coarse offtrack.</p> <p>Servo error; Three consecutive missing Servo IDs detected by Servo Processor</p>	C.4.3, "Recovered drive error" on page 285
1	0C	01	<p>Write Error Recovered With Auto Reallocation</p> <p>Recovered Write error, Auto Reallocated.</p>	C.3.3, "Data error logging" on page 283
1	0C	03	<p>Write Error - Recommend Reassignment</p> <p>Write Error, Recommend Reassignment</p>	C.3.2, "Reassign a physical sector" on page 282
1	14	01	<p>Record Not Found</p> <p>No sector found error (ID no sync. found).</p>	C.3.3, "Data error logging" on page 283

Table 162 (Page 3 of 19). Valid Sense Key, Code, Qualifier Combinations used by the drive.				
Key	Code	Qual	Description	Initiator Recovery
1	14	05	Record Not Found - Recommend Reassignment No sector found error(ID no sync. found), Recommend Reassignment.	C.3.2, “Reassign a physical sector” on page 282
1	14	06	Record Not Found - Data Auto-Reallocated No sector found error(ID no sync. found), Data Auto Reallocated.	C.3.3, “Data error logging” on page 283
1	15	00	Random Positioning Error Servo error; Unexpected Guardband detected. Servo error; Settle overshoot. Servo error; Maximum seek velocity exceeded. Servo error; Velocity too high at settle hand off.	C.4.3, “Recov- ered drive error” on page 285
1	15	02	Positioning Error Detected by Read of Medium Seek positioning error (ID miscompare).	C.4.3, “Recov- ered drive error” on page 285
1	16	00	Data Synchronization Mark Error No Data sync. found. Data Sync error detected while outside of the write band.	C.3.3, “Data error logging” on page 283
1	16	01	Data Synchronization Mark Error - Data Rewritten No Data sync. found, Data Rewritten	C.3.3, “Data error logging” on page 283
1	16	02	Data Synchronization Mark Error - Recommend Rewrite No Data sync. found, Recommend Rewrite	C.3.1, “Rewrite an LBA” on page 281
1	16	03	Data Synchronization Mark Error - Data Auto-Reallocated No Data sync. found, Data Auto Reallocated	C.3.3, “Data error logging” on page 283
1	16	04	Data Synchronization Mark Error - Recommend Reassignment No Data sync. found, Recommend Reassignment	C.3.2, “Reassign a physical sector” on page 282

Table 162 (Page 4 of 19). Valid Sense Key, Code, Qualifier Combinations used by the drive.				
Key	Code	Qual	Description	Initiator Recovery
1	17	01	Recovered Data with Retries ECC check corrected without using ECC correction. ECC Error Detected while outside of write band corrected without ECC. Recovered Verify Error with BytChk Option without ECC correction.	C.3.3, “Data error logging” on page 283
1	17	02	Recovered Data with Positive Head Offset Data recovered using positive offsets.	C.3.3, “Data error logging” on page 283
1	17	03	Recovered Data with Negative Head Offset Data recovered using negative offsets.	C.3.3, “Data error logging” on page 283
1	17	05	Recovered Data using previous sector ID Data recovered using No ID Recovery	C.3.2, “Reassign a physical sector” on page 282
1	17	06	Recovered Data Without ECC - Data Auto-Reallocated Recovered data without ECC, Auto Reallocated.	C.3.3, “Data error logging” on page 283
1	17	07	Recovered Data Without ECC - Recommend Reassignment Recovered data without ECC, Recommend Reassignment.	C.3.2, “Reassign a physical sector” on page 282
1	17	08	Recovered Data Without ECC - Recommend Rewrite Recovered data without ECC, Recommend Rewrite.	C.3.1, “Rewrite an LBA” on page 281
1	17	09	Recovered Data Without ECC - Data Rewritten Recovered data without ECC, Data Rewritten.	C.3.3, “Data error logging” on page 283

Table 162 (Page 5 of 19). Valid Sense Key, Code, Qualifier Combinations used by the drive.				
Key	Code	Qual	Description	Initiator Recovery
1	18	01	Recovered Data with Error Correction and Retries Applied Data correction applied to Drive data for a Data ECC check. ECC Error Detected while outside of write band corrected with ECC.	C.3.3, “Data error logging” on page 283
1	18	02	Recovered Data - Data Auto-Reallocated Recovered data with ECC, Auto Reallocated.	C.3.3, “Data error logging” on page 283
1	18	05	Recovered Data - Recommend Reassignment Recovered data with ECC, Recommend Reassignment	C.3.2, “Reassign a physical sector” on page 282
1	18	06	Recovered Data With ECC - Recommend Rewrite Recovered data with ECC, Recommend Rewrite.	C.3.1, “Rewrite an LBA” on page 281
1	18	07	Recovered Data With ECC - Data Rewritten Recovered data with ECC, Data Rewritten.	C.3.3, “Data error logging” on page 283
1	1C	01	Primary Defect List Not Found Requested P List does not match returned list format (READ DEFECT DATA only)	C.4.13, “Defect List Recovery” on page 292
1	1C	02	Grown Defect List Not Found Requested G List does not match returned list format. (READ DEFECT DATA only)	C.4.13, “Defect List Recovery” on page 292
1	1F	00	Partial Defect List Transferred Defect list longer than 64k, 64k of data returned. (READ DEFECT DATA only)	C.4.13, “Defect List Recovery” on page 292

Table 162 (Page 6 of 19). Valid Sense Key, Code, Qualifier Combinations used by the drive.				
Key	Code	Qual	Description	Initiator Recovery
1	44	00	<p>Internal Target Failure</p> <p>Servo Error; Invalid Servo Status Received by the Interface Processor</p> <p>Invalid SP Command Sequence.</p> <p>Illegal Head or Cylinder requested.</p> <p>A servo command is already active.</p> <p>Interface Processor detected Servo Sanity Error</p> <p>Controller/Channel Hardware detected Servo Sanity Error</p> <p>Servo error; Command not accepted while NOT in Retract.</p> <p>Servo error; Target Cylinder out of Range.</p> <p>Servo error; Command not accepted while in Retract.</p> <p>Servo Error; Invalid velocity detected during seek.</p> <p>Servo error; Head number out of range.</p> <p>Servo error; Invalid Command.</p> <p>Servo error; Offset out of range.</p> <p>Servo error; Loss of interrupts</p> <p>Interrupt Occured with no interrupt bits set.</p> <p>Motor Speed Error.</p> <p>Channel module Register Write Error</p> <p>Temporary loss of Motor Synchronization.</p> <p>Channel Module Write Parity Error</p> <p>Channel Module Read Parity Error</p> <p>Data Manager Write Parity Error</p> <p>Track Personalization Memory(TPM) Error</p> <p>Servo ID overrun Error</p> <p>Channel Module Write Unlock Error</p> <p>Arm Electronics(AE) Idle Error</p> <p>Interface Processor Ready Timeout Error</p> <p>Address Mark Enable(AMENA) After Sync.</p>	C.4.3, "Recovered drive error" on page 285
1	5C	02	<p>Spindles Not Synchronized</p> <p>Motor Synchronization lost, motor speed maintained.</p>	C.4.10.7, "Spindles Not Synchronized" on page 289

Table 162 (Page 7 of 19). Valid Sense Key, Code, Qualifier Combinations used by the drive.				
Key	Code	Qual	Description	Initiator Recovery
1	5D	00	<p><i>Predictive Failure Analysis Threshold Reached on Recovered Error</i></p> <p>Media Problem, Recommend Device Replacement</p> <p>Hardware Problem, Recommend Device Replacement</p> <p>Channel Noise Problem, Recommend Device Replacement</p> <p>Channel Assymetry Problem, Recommend Device Replacement</p> <p>Channel Precompensation Problem, Recommend Device Replacement</p> <p>Channel DC Offset Problem, Recommend Device Replacement</p> <p>Channel Timing Offset Problem, Recommend Device Replacement</p> <p>Fly Height Change Problem, Recommend Device Replacement</p> <p>Torque Amplification Problem, Recommend Device Replacement</p> <p>ECC On The Fly Hardware Problem, Recommend Device Replacement</p>	C.4.16, “Predictive failure analysis” on page 294
Sense Key = <i>Not Ready</i>				
2	04	00	<p><i>Logical Unit Not Ready Cause Not Reportable</i></p> <p>Motor Start Failed due to Timer 1 being disabled.</p> <p>Motor is Stuck, Cannot be started.</p> <p>Motor timeout error.</p> <p>Motor Thermal Shutdown</p>	C.4.4, “Drive not ready” on page 285
2	04	01	<p><i>logical unit is in the process of becoming ready</i></p> <p>Unavailable while Start Motor active.</p> <p>Unavailable while Spinup active.</p>	C.4.1, “Drive busy” on page 284
2	04	02	<p><i>Logical Unit Not Ready, initializing command required</i></p> <p>Degraded Mode/Motor not running.</p>	C.4.6, “Degraded Mode” on page 286
2	04	04	<p><i>Logical Unit Not Ready, Format in Progress</i></p> <p>Unavailable while Format active.</p>	C.4.1, “Drive busy” on page 284
2	31	00	<p><i>Medium Format Corrupted Reassign Failed</i></p> <p>Degraded Mode/Reassign Block unsuccessful after pushdown started.</p>	C.4.6, “Degraded Mode” on page 286

Table 162 (Page 8 of 19). Valid Sense Key, Code, Qualifier Combinations used by the drive.				
Key	Code	Qual	Description	Initiator Recovery
2	31	01	Format Command Failed Degraded Mode/Format unsuccessful.	C.4.6, “Degraded Mode” on page 286
2	40	80	Diagnostic Failure Degraded Mode/Bringup not successful.	C.4.6, “Degraded Mode” on page 286
2	40	85	Diagnostic Failure Degraded Mode/RAM Microcode not loaded, Download incomplete.	C.4.15, “Microcode error” on page 293
2	40	B0	Diagnostic Failure Self Init Reset, W/O Auto Motor Start	C.4.12, “Self Initiated Reset” on page 291
2	4C	00	Logical Unit Failed Self-Configuration Degraded Mode/Configuration not loaded. Degraded Mode/RAM Microcode not loaded.	C.4.6, “Degraded Mode” on page 286
Sense Key = Medium Error				
3	0C	02	Write Error - Auto-Reallocation Failed Recovered Write error, Auto Reallocate failed.	C.3.4, “Reassign Blocks Recovery” on page 284
3	0C	03	Write Error - Recommend Reassignment Write Error, Recommend Reassignment	C.3.2, “Reassign a physical sector” on page 282
3	11	00	Unrecovered Read Error Data ECC Check Data ECC Check detected while outside of the write band. Unrecovered Verify Error with BytChk Option before ECC check.	C.3.3, “Data error logging” on page 283
3	11	04	Unrecovered Read Error - Auto-Reallocation Failed Recovered Read Error, Auto reallocate failed because of unreadable data.	C.3.4, “Reassign Blocks Recovery” on page 284

Table 162 (Page 9 of 19). Valid Sense Key, Code, Qualifier Combinations used by the drive.				
Key	Code	Qual	Description	Initiator Recovery
3	11	0B	Unrecovered Read Error - Recommend Reassignment Unrecovered read error, Recommend Reassignment	C.3.2, “Reassign a physical sector” on page 282
3	14	00	Recorded Entity Not Found Track characterization failure. Unable to determine sector LBA due to adjacent read ID failures, with one sector defective. Reassign(pushdown not started) or Log Sense.	C.3.4, “Reassign Blocks Recovery” on page 284
3	14	01	Record Not Found No sector found error (ID no sync. found).	C.3.3, “Data error logging” on page 283
3	14	05	Record Not Found - Recommend Reassignment No sector found error(ID no sync. found), Recommend Reassignment.	C.3.2, “Reassign a physical sector” on page 282
3	16	00	Data Synchronization Mark Error No Data sync. found. Data Sync error detected while outside of the write band.	C.3.3, “Data error logging” on page 283
3	16	04	Data Synchronization Mark Error - Recommend Reassignment No Data sync. found, Recommend Reassignment	C.3.2, “Reassign a physical sector” on page 282
3	19	02	Defect List Error in Primary List. Error in Primary Defect list (READ DEFECT DATA only)	C.4.7, “Reserved Area Hard Error” on page 287
3	19	03	Defect List Error in Grown List. Error in Grown Defect list (READ DEFECT DATA only)	C.4.7, “Reserved Area Hard Error” on page 287
3	31	00	Medium Format Corrupted Reassign Failed Degraded Mode/Reassign Block unsuccessful after pushdown started. Unrecovered Read Error of Customer Data during Reassign after pushdown started.	C.3.4, “Reassign Blocks Recovery” on page 284

Table 162 (Page 10 of 19). Valid Sense Key, Code, Qualifier Combinations used by the drive.				
Key	Code	Qual	Description	Initiator Recovery
3	31	01	Format Failed Degraded Mode/Format unsuccessful.	C.4.6, “Degraded Mode” on page 286
Sense Key = Hardware Error				
4	01	00	No Index/Sector Signal No sector pulse found. Fake and Extra Index. Write with No Sector Pulses.	C.4.2, “Unrecovered drive error” on page 285
4	02	00	No Seek Complete Servo processor did not finish command in time. Servo error; Seek timeout. Servo error; Recalibrate Breakaway Failed Servo error; Recalibrate State 2 timeout Servo error; Recalibrate State 4 timeout Too many missing Servo IDs detected by Controller/Channel Hardware Servo error; Coarse offtrack Servo error; Recalibrate State A timeout Servo error; 3 Bad Servo ID's Servo error; Recalibrate State B timeout	C.4.2, “Unrecovered drive error” on page 285
4	03	00	Peripheral Device Write Fault Arm Electronics Not Ready. Arm Electronics error. Sector overrun error. Interface Processor write inhibit error. Microjog Write Inhibit IP Retract Error Write/Read Gate not detected during operation. External Write Inhibit.	C.4.2, “Unrecovered drive error” on page 285
4	09	00	Track Following Error Servo error; Loss of interrupts from the Controller/Channel Hardware. Servo error; Settle timeout. Servo error; Coarse offtrack. Servo error; Three consecutive missing Servo IDs detected by Servo Processor	C.4.2, “Unrecovered drive error” on page 285

Table 162 (Page 11 of 19). Valid Sense Key, Code, Qualifier Combinations used by the drive.				
Key	Code	Qual	Description	Initiator Recovery
4	11	00	Unrecovered Read Error in Reserved Area Data ECC Check (Reserved Area)	C.4.7, “Reserved Area Hard Error” on page 287
4	14	00	Recorded Entity Not Found No Sector Found caused by hardware fault or software.	C.4.2, “Unrecovered drive error” on page 285
4	14	01	Record Not Found - Reserved Area No sector found error (Reserved Area).	C.4.7, “Reserved Area Hard Error” on page 287
4	15	00	Random Positioning Error Servo error; Unexpected Guardband detected. Servo error; Settle overshoot. Servo error; Maximum seek velocity exceeded. Servo error; Velocity too high at settle hand off.	C.4.2, “Unrecovered drive error” on page 285
4	15	02	Positioning Error Detected by Read of Medium Seek positioning error (ID miscompare).	C.4.2, “Unrecovered drive error” on page 285
4	16	00	Data Synchronization Mark Error in Reserved Area No Data sync. found.(Reserved Area)	C.4.7, “Reserved Area Hard Error” on page 287
4	19	02	Defect List Error in Primary List. Error in Primary Defect list.	C.4.7, “Reserved Area Hard Error” on page 287
4	19	03	Defect List Error in Grown List. Error in Grown Defect list (used by Format Unit and Reassign Block commands).	C.4.7, “Reserved Area Hard Error” on page 287
4	31	00	Medium Format Corrupted Reassign Failed Unrecovered Hardware or Reserved area Data error during reassign after pushdown started.	C.3.4, “Reassign Blocks Recovery” on page 284

Table 162 (Page 12 of 19). Valid Sense Key, Code, Qualifier Combinations used by the drive.				
Key	Code	Qual	Description	Initiator Recovery
4	32	00	No Defect Spare Location Available GLIST full. Cannot add more entries. Entire track of defective sectors. No spare sectors remaining.	C.4.5, “No defect spare” on page 285
4	32	01	Defect list update failure Defect list update failure.	C.4.7, “Reserved Area Hard Error” on page 287
4	40	80	Diagnostic Failure Microcode Check Sum error detected during ROS Test. Microcode Check Sum error detected during RAM Test. Servo Data not present in CSR. Reserved area sector valid check failed. Configuration Sector valid check failed. Configuration Sector uploaded but Check Sum error. Reserved area sector version check failed.	C.4.6, “Degraded Mode” on page 286
4	40	85	Diagnostic Failure Microcode Check Sum error detected during download of Microcode. Microcode Check Sum error detected during upload of Microcode.	C.4.15, “Microcode error” on page 293
4	40	90	Diagnostic Failure BATS#2 Error. Track Personalization Memory(TPM) Error. Servo Data Verify Failure. BATS#2 Error; Seek test failure. BATS#2 Error; Head Offset Test failure. BATS#2 Error. Palette RAM test failure. BATS#2 Error. Digital Filter RAM test failure.	C.4.6, “Degraded Mode” on page 286
4	40	A0	Diagnostic Failure BATS#2 Error. Read write test failure. BATS#2 Error. ECC/CRC test failure. BATS#2 Error. LRC test failure.	C.4.6, “Degraded Mode” on page 286
4	40	B0	Diagnostic Failure Self Init Reset, W Auto Motor Start	C.4.12, “Self Initiated Reset” on page 291

Table 162 (Page 13 of 19). Valid Sense Key, Code, Qualifier Combinations used by the drive.				
Key	Code	Qual	Description	Initiator Recovery
4	40	C0	<p><i>Diagnostic Failure</i></p> <p>Mismatch between the Servo Processor ROS and Interface Processor RAM.</p> <p>Mismatch between the Interface Processor RAM and DE.</p> <p>Mismatch between the Interface Processor ROS and RAM.</p>	C.4.11, "Components Mismatch" on page 290
4	40	D0	<p><i>Diagnostic Failure</i></p> <p>Mismatch between the Servo Processor and the Reference Track Image.</p> <p>Mismatch between the Servo Processor ROS and DE.</p> <p>Mismatch between the Interface Processor ROS and the DE.</p>	C.4.11, "Components Mismatch" on page 290

Table 162 (Page 14 of 19). Valid Sense Key, Code, Qualifier Combinations used by the drive.				
Key	Code	Qual	Description	Initiator Recovery
4	44	00	<p>Internal Target Failure</p> <p>Defect List Error prevented one or more defects from being used in a format Unit command or from being reported in a Read Defect Data command.</p> <p>Too few valid GEM measurements available to perform a GEM Predictive Failure Analysis.</p> <p>ROS Microcode Download Failed.</p> <p>Mismatch between the Interface Processor ROS and Servo Processor ROS.</p> <p>Failure to load Servo Microcode into RAM.</p> <p>Buffer Controller Chip Channel A Error</p> <p>SCSI Controller Chip internal parity error.</p> <p>SCSI Controller Chip detected an LRC error during read.</p> <p>Reassign could not find the target LBA.</p> <p>Servo Error; Invalid Servo Status Received by the Interface Processor</p> <p>Sanity Error during Read Capacity execution.</p> <p>Target unexpectedly went Bus Free. (Bus Free)</p> <p>SCSI interrupt invalid. (Bus Free)</p> <p>SP interrupt on but SP Status Valid bit is off.</p> <p>Format Track parameter error (number of sectors and number of ID's do not match).</p> <p>Invalid SP Command Sequence.</p> <p>Illegal Head or Cylinder requested.</p> <p>A servo command is already active.</p> <p>Interface Processor detected Servo Sanity Error</p> <p>Controller/Channel Hardware detected Servo Sanity Error</p> <p>Buffer too small to do a requested function.</p> <p>Servo error; Command not accepted while NOT in Retract.</p> <p>Servo error; Target Cylinder out of Range.</p> <p>Servo error; Command not accepted while in Retract.</p> <p>Servo Error; Invalid velocity detected during seek.</p> <p>Servo error; Head number out of range.</p> <p>Servo error; Invalid Command.</p>	C.4.2, "Unrecovered drive error" on page 285

Table 162 (Page 15 of 19). Valid Sense Key, Code, Qualifier Combinations used by the drive.				
Key	Code	Qual	Description	Initiator Recovery
4	44	00	<p>Internal Target Failure</p> <p>Servo error; Offset out of range.</p> <p>Servo error; Loss of interrupts</p> <p>SP lost.</p> <p>Interrupt Occured with no interrupt bits set.</p> <p>Motor Speed Error.</p> <p>Channel module Register Write Error</p> <p>Temporary loss of Motor Synchronization.</p> <p>Servo error; Loss of interrupts</p> <p>Servo error; Servo Nonvolatile Storage RAM error</p> <p>Buffer Controller Chip Sequencer Error</p> <p>Buffer Controller Chip Error</p> <p>Disk Manager Chip detected an LRC error during write.</p> <p>Channel Module Write Parity Error</p> <p>Channel Module Read Parity Error</p> <p>Data Manager Write Parity Error</p> <p>Track Personalization Memory(TPM) Error</p> <p>Servo ID overrun Error</p> <p>Channel Module Write Unlock Error</p> <p>Arm Electronics(AE) Idle Error</p> <p>Interface Processor Ready Timeout Error</p> <p>Address Mark Enable(AMENA) After Sync.</p> <p>Invalid UEC</p>	C.4.2, “Unrecovered drive error” on page 285
4	5C	02	<p>Spindles Not Synchronized</p> <p>Motor Synchronization lost, motor speed maintained.</p>	C.4.10.7, “Spindles Not Synchronized” on page 289
Sense Key = <i>Illegal Request</i>				
5	1A	00	<p>Parameter List Length Error</p> <p>Command parameter list length error.</p>	C.4.8, “Interface Protocol” on page 287
5	20	00	<p>Invalid Command Operation Code</p> <p>Invalid Op. code.</p>	C.4.8, “Interface Protocol” on page 287

Table 162 (Page 16 of 19). Valid Sense Key, Code, Qualifier Combinations used by the drive.				
Key	Code	Qual	Description	Initiator Recovery
5	21	00	Logical Block Address out of Range Invalid LBA.	C.4.8, “Interface Protocol” on page 287
5	24	00	Invalid Field in CDB CDB Invalid. Data length error on Read Long or Write Long. Invalid Buffer ID in Write Buffer Command.	C.4.8, “Interface Protocol” on page 287
5	25	00	Logical Unit Not Supported Invalid LUN.	C.4.8, “Interface Protocol” on page 287
5	26	00	Invalid Field in Parameter List Command parameter data invalid. Microcode and Load ID mismatch during Write Buffer Command. Invalid field in Parameter Data, See Field Pointer Value. Invalid LBA in Reassign Command when Reassign degraded. Microcode and Servo Processor ROS mismatch during Write Buffer Command. Microcode and DE mismatch during Write Buffer Command. Microcode and Interface Processor ROS mismatch during Write Buffer Command. Microcode and Interface Processor RAM mismatch during Write Buffer Command.	C.4.8, “Interface Protocol” on page 287
5	3D	00	Invalid Bits in Identify Message Reserved bits in Identify message are non zero. (Bus Free)	C.4.9, “Aborted Command” on page 288
Sense Key = <i>Unit Attention</i>				
6	28	00	Not Ready To Ready Transition, (Medium may have changed) Unit Attention/Not Ready to Ready Transition(Format Completed)	C.4.10.1, “Not Ready to Ready Transition” on page 289
6	29	00	Power On, Reset, or Bus Device Reset occurred Unit Attention/POR. Unit Attention/Self Initiated Reset.	C.4.10.2, “Reset” on page 289

Table 162 (Page 17 of 19). Valid Sense Key, Code, Qualifier Combinations used by the drive.				
Key	Code	Qual	Description	Initiator Recovery
6	2A	01	Mode Parameters Changed Unit Attention/Mode Select Parameters have changed.	C.4.10.3, “Mode Parameters Changed” on page 289
6	2A	02	Log Select Parameters Changed Unit Attention/Log Parameters Changed	C.4.10.8, “Log Select Parameters Changed” on page 290
6	2F	00	Commands Cleared by Another Initiator Unit Attention/Command cleared by another initiator.	C.4.10.5, “Commands Cleared by Another Initiator” on page 289
6	3F	01	Microcode has been changed Unit Attention/Write Buffer.	C.4.10.4, “Microcode has Changed” on page 289
6	5C	01	Spindles Synchronized Unit Attention/Spindles Synchronized	C.4.10.6, “Spindles Synchronized” on page 289
6	5C	02	Spindles Not Synchronized Unit Attention/Spindles not Synchronized.	C.4.10.7, “Spindles Not Synchronized” on page 289
Sense Key = Data Protect				
7	27	00	Write Protected Command not allowed while in Write Protect Mode.	1.6.2, “Page 0 - Vendor Unique Parameters” on page 75
Sense Key = Aborted Command				

Table 162 (Page 18 of 19). Valid Sense Key, Code, Qualifier Combinations used by the drive.				
Key	Code	Qual	Description	Initiator Recovery
B	1B	00	<i>Synchronous Data Transfer Error</i> Synchronous transfer error, Extra pulses on synchronous transfer.	C.4.9, “Aborted Command” on page 288
B	25	00	<i>Logical Unit Not Supported</i> Different LUN addressed (Identify message) from first selected. (Bus Free)	C.4.9, “Aborted Command” on page 288
B	43	00	<i>Message Error</i> Required disconnection was not allowed. A CIOP message was received on an initial connection. (Bus Free) Cannot resume the operation (Data transfer). Innapropriate Message Reject message received. (Bus Free) Attention dropped too late. (Bus Free) Message parity error received when no message sent by Target. (Bus Free)	C.4.9, “Aborted Command” on page 288
B	44	00	<i>Internal Target Failure</i> Command aborted due to Fatal Hardware error.	C.4.9, “Aborted Command” on page 288
B	45	00	<i>Select or Reselect Failure</i> Reselection timeout. (Bus Free)	C.4.9, “Aborted Command” on page 288
B	47	00	<i>SCSI Parity Error</i> Unrecovered SCSI parity error detected by Target during a command or data phase. Unrecovered SCSI parity error detected by the Target during a MESSAGE OUT phase. (Bus Free) Unrecovered SCSI parity error detected by the Initiator (Message Parity Error Message). (Bus Free)	C.4.9, “Aborted Command” on page 288
B	48	00	<i>Initiator Detected Error Message Received</i> Initiator Detected Error for other than STATUS or linked COMMAND COMPLETE phase. Initiator Detected Error message for STATUS or Linked COMMAND COMPLETE phase. (Bus Free)	C.4.9, “Aborted Command” on page 288

Table 162 (Page 19 of 19). Valid Sense Key, Code, Qualifier Combinations used by the drive.				
Key	Code	Qual	Description	Initiator Recovery
B	49	00	Invalid Message Error Invalid message or attention dropped before all bytes of an extended message are transferred. (Bus Free)	C.4.9, “Aborted Command” on page 288
B	4E	00	Overlapped Commands Attempted Invalid Initiator Connection.	C.4.9, “Aborted Command” on page 288
Sense Key = Miscompare				
E	1D	00	Miscompare During Verify Operation Miscompare during byte by byte verify.	C.4.14, “Miscompare recovery” on page 292

Byte 14 Field Replaceable Unit Code

A Field Replaceable Unit Code of zero indicates that no specific mechanism or unit has been identified to have failed or that the data is not available.

A non-zero Field Replaceable Unit Code identifies the extended VPD page which describes the specific mechanism or unit that has failed. These extended VPD pages of the Inquiry command contain information about the field replaceable unit.

Byte 15 - 17 Sense Key Specific

The meaning of the Sense-Key Specific Field, bytes 15-17, depends on which sense key is returned and whether the sense-key specific valid (SKSV) bit is one.

If the SKSV bit is zero, then sense-key specific field is unused and is zero.

If the sense key is **Recovered Error** or **Medium Error** or **Hardware Error**, and if the SKSV bit is one, then the Sense-Key Specific Field shall be defined as shown in Table 163. These fields identify the actual number of retries used in attempting to recover from the error condition.

Table 163. Actual Retry Count Bytes								
Byte	BIT							
	7	6	5	4	3	2	1	0
15	SKSV = 1	RSVD = 0						
16 17	(MSB)	Actual Retry Count						(LSB)

The Actual Retry Count field returns the final step number of the DRP or ERP action that was used to attempt recovery from an error.

If the sense key is **Not Ready** and the SKSV bit is one, then the Sense-Key Specific Field shall be defined as shown in Table 164. These fields define an indication of progress in completing the *Format Unit* command.

Table 164. Progress Indication Bytes								
Byte	BIT							
	7	6	5	4	3	2	1	0
15	SKSV = 1	RSVD = 0						
16 17	(MSB)	Progress Indication						(LSB)

The Progress Indication Field is a fraction complete indication in which the returned value is the numerator that has 65536 as its denominator.

Progress indication is only given for the *Format Unit* command with the Immed bit set to 1. Therefore, if the sense key is then the SKSV bit is only set to 1 if the additional sense code is Format In Progress.

If the sense key is *Illegal Request* and the SKSV bit is one, then the Sense-Key Specific Field shall be defined as shown in Table 165. These fields designate the bytes and bits in error in the *Mode Select* command parameter bytes.

Table 165. Field Pointer Bytes							
Byte	BIT						
	7	6	5	4	3	2	1 0
15	SKSV = 1	C/D	RSVD = 0		BPV	Bit Pointer	
16 17	(MSB)	Field Pointer (LSB)					

A Command Data (C/D) bit of one indicates that the illegal parameter is in the command descriptor block. A C/D bit of zero indicates that the illegal parameter is in the data parameter sent by the initiator during the DATA OUT phase.

A Bit Pointer Value (BPV) bit of zero indicates that the value in the bit pointer field is not valid. A BPV bit of one indicates that the bit pointer field specifies which bit of the byte designated by the Field Pointer Field is in error. When a multiple-bit field is in error, the bit pointer field shall point to the most significant (left most) bit of the field. When multiple fields in a byte are in error, the bit pointer field points to the most significant (left most) field in error.

The Field Pointer Field indicates which byte of the command descriptor block or the parameter data that was in error. Bytes are numbered starting from zero. When a multiple byte field is in error, the pointer shall point to the most significant (left most) byte of the field in error.

Bytes 18 - 19 Reserved
Byte 20 - 21 Unit Error Code

The UEC gives detailed information about the error. It contains a unique code which describes where the error was detected and which piece of hardware or microcode detected the error.

Bytes 22 - 23 Reserved

Byte 24 - 29

Physical Error Record

- ILI = 1 - This field contains zeros.
- ILI = 0 - These bytes contain the physical location of the error as cylinder, head and sector. Bytes 24 and 25 are Cylinder high and Cylinder low respectively. Byte 26 is the head number. Bytes 28 and 29 are sector high and sector low respectively.

Byte 27 is retained for compatibility with previous members of this product family and will contain the sector number for sectors 0 through 254 and will be set to 0FFh for sector numbers greater than 254 or if the sector number is undetermined.

If the head is undetermined, its value is set to 0FFh. If the Cylinder value is undetermined, bytes 24 and 25 are set to 0FFFFh. If the sector number is undetermined bytes 27, 28, and 29 are all set to 0FFh.

This field is valid with Sense Key 1, 3 and 4 only. If Cylinder, Head, and Sector have no relevance to the Error, Bytes 24 through 29 will all be set to 0FFh.

Bytes 30 - 31

Reserved

Appendix B. Recovery Procedures

The following sections describe the recovery procedures for each of the various types of errors for which recovery is attempted.

B.1 Data Recovery Procedure for Data Field Errors

The following table lists the steps that have been defined for data recovery. These recovery actions are for Sync Byte, Data ECC and No Sector Found errors on read commands.

Definitions for the following tables.

- Reread - Read with no parameters altered.
- Rewrite - Write with no parameters altered.
- Read Bias - 0 = Normal Bias Current in Read Head, +1 = Increase Bias Current in Read Head by 1 unit, -1 = Reduce Bias Current in Read Head by 1 unit.
- TO - Track Offset movement of the Read Head slightly off center. The percent indicates the fraction of a track width. The sign indicates the direction of the movement with + being toward the inner diameter of the data surface.
- ECC Burst - Amount of ECC correction applied. Double Burst will correct a 41 bit error and under certain conditions can correct up to a 48 bit error. These are errors per physical sector.
- DA - Double burst ECC correction on adjacent error bytes.
- DR - Double burst ECC correction on adjacent or random
- TB - Triple burst ECC correction on adjacent error bytes. This allows 9 bytes in error to be corrected.
- SAT - Surface Analysis Test ECC correction on adjacent error bytes. This allows certain 14 byte errors to be corrected when a thermal asperity is involved.
- EQ - Equalizer Adjust, the Channel Hardware is set to a fixed mode with the equalizer adjusted based on the amount shown.
- TA Mode - Set the channel to thermal asperity recovery mode regardless of whether a thermal asperity was detected or not.
- NSF - No Sector Found error.
- NO ID Mode - Data recovery using tangentially adjacent sector IDs to determine the physical location of the NSF ID. A physical operation is performed to read or write the data.
- HSC - Head State Change, A short write is done in the non-customer data area to change the residual head state characteristics.
- VCO Calibrate - Calibrates the Voltage Controlled Oscillator in the Channel Hardware.
- A/D Calibrate - Calibrates the Analog to Digital Converter in the Channel Hardware.
- Scrub - Movement of the head in an attempt to recovery from an error possibly caused by a Thermal Asperity. Scrub is done in a particular direction, either toward the Inner Diameter(ID) or toward the Outer Diameter(OD). Asperity off the disk. Several disk revolutions are taken on each step which employs this type of recovery.
- Read Gate Adjust Recovery - Adjust where Data Sync is read in an attempt to avoid a Thermal Asperity in the Data Sync Field. The amount of adjust is fixed. The polarity of the adjust can be early or late.

B.1.1 Read Commands

Table 166 (Page 1 of 2). Read Recovery Steps				
DRP Steps	Action	Read Bias	ECC Burst	Miscellaneous
0	Initial Read	0		Count NSF.
1-3	Reread	0		Count NSF.
4	Reread	+1		HSC prior to step 4.
5	+9% TO	0		
6	-9% TO	0		
7	+15% TO	0		
8	-15% TO	0		
9	+1 EQ	0		Enable TA mode prior to step 9 for remainder of DRP.
10	-1 EQ	0		
11-13	Reread	0		Recalculate cylinder and head and reseek prior to step 11 if NSF count is greater than 1, then zero NSF count. HSC prior to step 13. Count NSF. Count Data Sync Errors.
14	Reread	+1		HSC prior to step 14. Count NSF.
15-16	Reread	0		Enable No ID Mode prior to step 15 if NSF count is greater than 0. Count Data Sync Error.
17	Reread	+1		HSC prior to step 17. Count Data Sync Error.
18	+6% TO	0		If the Data Sync Error Count is greater than 0 then enable Read Gate Adjust Recovery prior to step 18 and alternate polarity(late or early) of the adjust every other step up to and including step 47. If the Data Sync Error is recovered but an ECC error occurs then maintain the Read Gate Adjust polarity for the remaining steps.
19	-6% TO	0		
20	+12% TO	0		
21	-12% TO	0		
22	+18% TO	0		
23	-18% TO	0		
24	+1 EQ	0		
25	-1 EQ	0		
26	Reread	0	DA	Recalculate cylinder and head and reseek prior to step 26.
27	Reread	+1	DA	
28	Reread	-1	DA	HSC prior to step 28.
29	+6% TO	0	DA	
30	-6% TO	0	DA	

Table 166 (Page 2 of 2). Read Recovery Steps				
DRP Steps	Action	Read Bias	ECC Burst	Miscellaneous
31	+12% TO	0	DA	
32	-12% TO	0	DA	
33	+1 EQ	0	DR	
34	-1 EQ	0	DR	
35	Reread	0	DR	
36	Reread	+1	DR	OD Scrub prior to step 36.
37	Reread	-1	DR	HSC prior to step 37.
38	Reread	0	DR	VCO Calibrate prior to step 42.
39	Reread	0	TB	A/D Calibrate prior to step 39.
40	+6% TO	0	TB	ID Scrub prior to step 40.
41	-6% TO	0	TB	
42	+12% TO	0	TB	OD Scrub prior to step 42.
43	-12% TO	0	TB	
44	+18% TO	0	TB	ID Scrub prior to step 44.
45	-18% TO	0	TB	
46	+1 EQ	0	TB	OD Scrub prior to step 46.
47	-1 EQ	0	TB	
48	-6% TO	0	SAT	
49	+6% TO	0	SAT	
50	Reread	0	SAT	

B.1.2 Verify Commands

The recovery procedures for *Write and Verify (2Eh)* and *Verify (2Fh)* commands are as follows. It is important to understand two items relative to verify.

1. A failed command that does verifies is considered a hard error if the byte by byte option is in effect and a miscompare, error confirmed to be non-ECC detected, occurs. The sense key reported for this error is Eh (Miscompare Error during Verify byte by byte Operation).
2. In all other cases, a failed command that does verifies in not considered a hard error. Although the Drive will return a sense key of 3h (Medium Error) the error is not unrecoverable since Verify recovery is not nearly as extensive as normal read recovery. A subsequent read with full recovery should successfully read the data.

Note: "On the Fly ECC" correction is not done when the byte-by-byte option is in effect.

B.1.2.1 Write and Verify

Table 167. Write and Verify Recovery Steps				
DRP Steps	Action	Read Bias	ECC Burst	Miscellaneous
0	Initial Read	0		Count NSF.
1-3	Reread	0		Count NSF.
4	Reread	+1		HSC prior to step 4.
5-7	Reread	0		Recalculate cylinder and head and reseek prior to step 5 if NSF count is greater than 1. HSC prior to step 7.
8	Reread	+1		HSC prior to step 8.
9	Reread	0		

B.1.2.2 Verify

Table 168. Verify Recovery Steps				
DRP Steps	Action	Read Bias	ECC Burst	Miscellaneous
0	Initial Read	0		Count NSF.
1-3	Reread	0		Count NSF.
4	Reread	+1		HSC prior to step 4.
5-7	Reread	0		Recalculate cylinder and head and reseek prior to step 5 if NSF count is greater than 1. HSC prior to step 7.
8	Reread	+1		HSC prior to step 8.
9	+9% TO	0		
10	-9% TO	0		
11	+15% TO	0		
12	-15% TO	0		
13	+1 EQ	0		
14	-1 EQ	0		
15	Reread	0		VCO Calibrate prior to step 15.
16	Reread	0		A/D Calibrate prior to step 16.
17	+6% TO	0		
18	-6% TO	0		
19	+12% TO	0		
20	-12% TO	0		
21	+18% TO	0		
22	-18% TO	0		
23	+1 EQ	0		
24	-1 EQ	0		
25	Reread	0		

B.1.3 Write Commands (No Sector Found)

Step	Action	Read Bias	Miscellaneous
0	Initial Write	0	
1-3	Rewrite	0	HSC prior to step 3.
4	Rewrite	+1	HSC prior to step 4.
5-7	Rewrite	0	Recalculate cylinder and head and reseek prior to step 5. HSC prior to step 7.
8	Rewrite	+1	HSC prior to step 8.
9	Rewrite	-1	
10	Rewrite	0	OD Scrub prior to step 10.
11	Rewrite	0	ID Scrub prior to step 11.
12	Rewrite	0	No ID Mode.

B.2 Error Recovery for Non-Data Errors

Errors other than data errors as described above invoke Error Recovery Procedures called ERP. ERP errors fall into 4 classes:

- Drive Fault
- Position (Servo)
- Spindle Motor
- Spindle Synchronization Errors.

B.2.1 Position Error (Servo Error Recovery)

Step	Action	Read Bias	Miscellaneous
0	Initial Servo Operation	0	
1-3	Retry Servo Operation	0	Recalibrate, Seek to last good location, prior to step 1-3.

B.2.2 Drive Fault

Step	Action	Read Bias	Miscellaneous
0	Initial Read/Write	0	
1-9	Reread/Rewrite	0	Recalibrate, Seek to last good location prior to step 9.

B.2.3 Spindle Motor Error

A spindle motor error is generated when motor speed can not be maintained. The motor will be stopped and a Not Ready sense key is returned. There is no self initiated recovery taken by the Drive for this error.

B.2.4 Spindle Synchronization Error

A spindle synchronization error occurs when the target spindle loses synchronization with the master. For information on how this condition is reported, see 4.5, “Motor Synchronization” on page 225. When this condition occurs, the target reverts to unsynchronized operation. Read and write operations are not affected by the synchronization loss.

B.3 Priority of Error Reporting

Multiple errors can occur during the execution of a command. Since only one error is reported in the sense data, a priority scheme for determining which error to report is used. Following are the rules for reporting sense data:

- Hard Errors
 - An unrecovered (hard) error will always be reported in place of any soft error that may have occurred during the same operation.
 - If multiple hard error conditions exist, the first hard error detected will be reported.
- Soft Errors
 - When PER=0 (*Mode Select* data format Page 1), recovered data and non-data errors are not reported.
 - When PER=1 (*Mode Select* data format Page 1), the last error detected will be reported.

If an unrecoverable error occurs during idle time, it is reported by the next command processed even though the error may seem inappropriate for that command.

Appendix C. Recommended Initiator Error Recovery Procedures

The Drive's design points for error reporting to the system assumes certain system action for the error return codes. These assumptions are:

1. SCSI-2 protocol will be the first priority in reporting errors.
2. The system will maintain a log of all reported errors.
3. System architecture should include all error handling recommendations made in this appendix. Deviations should have mutual agreement between Drive development and system integration.

This section of the appendix is directed toward documenting the assumptions made by the Drive that the system is expected to implement. The two error classes that the system should be concerned with are DATA and NON-DATA errors.

Data errors are those errors that deal with the handling of data to and from the MEDIA and are identified by the additional sense code contained in the sense data. The additional sense codes for data errors are

- 0C - Write error
- 11 - Unrecovered read error
- 14 - No record found
- 16 - Data Synchronization mark error
- 17 - Recovered read error without ECC correction
- 18 - Recovered read error with ECC correction

Typically, data errors do not include positioning of the heads or the data path through the electronics.

Non-data errors are those errors that do not have a direct relationship with transferring data to and from the media. Non-data errors can include data handling if the media is not associated with the error (i.e. interface errors).

The system action assumed for each class of error is outlined here. System integrators should be aware that deviating from these recommendations can affect drive performance and the system service strategy.

C.1 Drive service strategy

The Drive service strategy is defined so the customer will be able to use the system as soon after a failure is detected as possible. The first priority is to replace the entire drive to make the system operational with minimal service time. The service representative should:

1. Back up all the customer data on this drive if possible
2. Replace the complete drive
3. Restore the customer data
4. Return the drive to customer service

Drive development recognizes the need to preserve customer data. Therefore, there is a procedure that will allow the service representative to replace the electronics portion of the drive at the customer location. This procedure should only be attempted when customer data is critical. If customer data is not critical, then complete drive replacement is recommended. To replace the electronics assembly, the service representative should:

1. Since data cannot be backed up, replace the electronics assembly per the instructions
2. Restore the drive to service
3. If drive performance is questionable after replacing the electronics assembly, back up customer data if possible, then replace the complete drive. Questionable performance can be a high number of recovered errors or reduced data throughput.

The service representative should **NEVER** attempt to replace only the head/disk assembly (HDA).

C.2 Recommendations for System Error Log

The system error log should contain information about the Drive error that will allow recovery actions. The system error logs should contain all the error information returned in the sense data. At a minimum the following information about each error occurrence should be logged.

- Valid bit and error code (Sense byte 0)
- Sense Key (Sense byte 2)
- Information bytes (Sense bytes 3 thru 6)
- Command specific information (Sense bytes 8 thru 11)
- Additional Sense code (sense byte 12)
- Additional Sense code qualifier (sense byte 13)
- Field Replaceable Unit (Sense byte 14)
- Sense Key Specific (sense bytes 15, 16, and 17)
- UEC (Sense bytes 20 & 21)
- Error Record - Physical Block Address (Sense bytes 24 thru 27)

C.3 Data Recovery Procedure

Statistically, most data error activity is noise related and has nothing to do with defects in the media. It is wrong for the system to assume that every data error reported occurred because of a defect in the media. It is also wrong for the system to assume that every data error that occurred because of a media defect rendered the Drive unusable.

Recurring data error activity at the same physical location is an indication of a problem. The problem can be due to a media defect or magnetic damage. A media defect is physical damage to the recording capability of the media while magnetic damage is a defect in the bit pattern written to the media.

The system recovery action to correct these types of defects differs. In both cases, the error can be corrected without replacing the unit. For media defects, the physical sector may require relocation. For magnetic defects, a rewrite of the failing LBA may be all that is required. The Drive determines the need to either rewrite or reassign a sector. The Mode Select page 1 option bits, 1.6, “Mode Select (6)” on page 70, AWRE/ARRE active allows the Drive to rewrite or relocate recovered data errors. Non-recovered data errors and AWRE/ARRE inactive will have additional sense codes returned to recommend rewrite or reassignment of sectors.

For the cases where a rewrite is recommended, the initiator should write the data using the *Write and Verify (2E)* command. The verify portion of the *Write and Verify (2E)* command uses limited error recovery, which is desirable in this case. The initiator may elect to verify the write with byte check (*Write and Verify (2E)* command CDB byte 1, bit 1) enabled or disabled.

The need to reassign a sector should be infrequent. Sites not meeting error rate criteria are removed from use during SAT (Surface Analysis Test) in Drive manufacturing. With the exception of some early life SAT escapes (sites that were marginally missed during SAT), reassigning defective sectors should be rare.

Frequent sector reassignment may be an (early) indication of another type of failure. Sector reassignments are monitored as part of the predictive failure analysis. When a threshold is exceeded, the Drive will notify the initiator that a scheduled service action is required.

Drive soft error rates are based on extraneous random faults that are not predictable. Media defects discovered after the Drive completes manufacturing final test need to be relocated so that soft error rates are not influenced by predictable known error sites. Failure of the system to properly relocate defective media sites can have a direct influence on system throughput and drive error rates.

C.3.1 Rewrite an LBA

The Drive determines the need to rewrite a logical block address (LBA) based on error activity. Once a LBA requires rewriting, the Drive will either rewrite the LBA, or recommend to the initiator that the LBA be rewritten.

When the following sense key, additional sense code, and additional sense code qualifier combinations are returned, the initiator should rewrite the LBA reported in the sense at the next opportunity.

NOTE: In Table 172 the Key, Code, and Qualifier fields are all hex values. (i.e. Sense key 1 is 1h, sense code 17 is 17h, etc)

Table 172. Recommend Rewrite errors. Sense data combinations for recommend rewrite of an LBA.			
Key	Code	Qual.	Description
1	16	02	Data Synchronization Byte Error - recommend Rewrite.
1	17	08	Recovered data without ECC - Recommend Rewrite.
1	18	06	Recovered data with ECC - Recommend Rewrite.

To rewrite a LBA that has sense data recommending a rewrite, the initiator should rewrite the data using the *WRITE and VERIFY (2E)* command. If the *WRITE and VERIFY (2E)* command completes:

- Successfully (GOOD status) or check condition status for recovered data error, log the error in the system error log.
- Unsuccessfully (Check Condition status) for a medium error, reassign the LBA using the *Reassign Blocks (07)* command.
- Unsuccessfully (Check Condition status) for any error other than recovered data error or medium error, follow the recommendations for the error codes reported.

C.3.2 Reassign a physical sector

The Drive determines the need to reassign physical sectors based on error activity. Once a physical sector requires reassignment, the Drive will either reassign the physical sector, or recommend to the initiator that the LBA associated with the physical sector be reassigned.

When the following sense key, additional sense code, and additional sense code qualifier combinations are returned, the initiator should reassign the LBA reported at the next opportunity.

NOTE: In Table 173 the Key, Code, and Qualifier fields are all hex values. (i.e. Sense key 1 is 1h, sense code 17 is 17h, etc)

Table 173. Recommend Reassign errors. Sense data combinations for recommend reassignment.			
Key	Code	Qual.	Description
1	0C	03	Write Error - Recommend Reassignment.
1	14	05	Record Not Found - Recommend Reassignment.
1	16	04	Sync Byte Error - Recommend Reassignment.
1	17	05	Recovered data using previous ID
1	17	07	Recovered data without ECC - Recommend Reassignment.
1	18	05	Recovered data with ECC - Recommend Reassignment.
3	0C	03	Write Error - Recommend Reassignment.
3	11	0B	Unrecovered read error - Recommend Reassignment.
3	14	05	Record Not Found - Recommend Reassignment.
3	16	04	Sync Byte Error - Recommend Reassignment.

To reassign an LBA that has sense data recommending a reassignment, the initiator should:

1. Attempt to recover the data from the sector being reassigned with a *Read (08) or Read (28)* command.
2. Reassign the LBA using the *Reassign Blocks (07)* command. If the reassignment completes:
 - Successfully (GOOD status), log the error in the system error log.

- Unsuccessfully (Check Condition status), follow the C.3.4, “Reassign Blocks Recovery” on page 284 procedure.

3. Write the LBA that was reassigned.

When a LBA is reassigned, the physical location of all LBAs from the LBA being reassigned to the location of the next available spare changes. Initiators wanting to reassign more than one LBA should reassign the largest LBA first and the following LBAs in descending order. All candidates for reassignment are listed in page 32 of log sense data. Refer to 1.5, “Log Sense” on page 52.

C.3.3 Data error logging

The Drive will report data errors to the initiator that do not require immediate action (successful auto reallocation, successful auto rewrite, or no action needed on this occurrence). The initiator should log these errors in the system error log. No other action is required.

NOTE: In Table 174 the Key, Code, and Qualifier fields are all hex values. (i.e. Sense key 1 is 1h, sense code 17 is 17h, etc)

Table 174. Log Only errors. Sense data combinations for automatic rewrite or reallocate or that requires no system action except log.			
Key	Code	Qual.	Description
1	0C	01	Recovered Write error - Auto Reallocated.
1	14	01	Record not found
1	14	06	Record Not Found - data Auto-Reallocated.
1	16	00	Data synchronization mark error
1	16	01	Sync Byte Error - data Rewritten.
1	16	03	Sync Byte Error - data auto-reallocated.
1	17	01	Recovered data with retries
1	17	02	Recovered data with positive offset
1	17	03	Recovered data with negative offset
1	17	06	Recovered data without ECC - Auto Reallocated.
1	17	09	Recovered data without ECC - Data Rewritten.
1	18	01	Recovered data with error correction and retries applied
1	18	02	Recovered data with ECC - Auto Reallocated.
1	18	07	Recovered data with ECC - Data Rewritten.
3	11	00	Unrecovered read error - Limited DRP set by initiator
3	14	01	Record not found
3	16	00	Data synchronization mark error

C.3.4 Reassign Blocks Recovery

The Drive provides the capability to remove media defects without reducing capacity. If the mode parameter bits ARRE/AWRE are active, the Drive will automatically reallocate LBAs determined to be defective. For those LBAs where the error is unrecoverable or the initiator elects to not have the Drive automatically reallocate LBAs, the Drive will recommend reassignment of the LBA.

Recovery from a failed reassignment is to:

- Retry the *Reassign Blocks (07)* command to the same LBA as the failed *Reassign Blocks (07)* command. Note: the LBA of the failed *Reassign Blocks (07)* command is in the command specific bytes of the sense data.
- If the retried *Reassign Blocks (07)* command completes successfully, return to normal processing.
- If the retried *Reassign Blocks (07)* command fails, service the drive using the service guidelines recommended in the C.1, “Drive service strategy” on page 279.

C.4 Non-Data Error Recovery Procedure

The Drive will follow a logical recovery procedure for non-data errors. The initiator options for non-data errors are limited to logging the error, retrying the failing command, or replacing the drive.

These recovery procedures assume the initiator practices data back-up and logs errors at the system level for interrogation by service personnel.

C.4.1 Drive busy

The Drive is busy performing an operation. Refer to the *product Functional Specification* for time-out limits. **This is not an error condition.** The initiator can test for completion of the operation by issuing a *Test Unit Ready (00)* (media access) command.

- If the *Test Unit Ready (00)* (or media access) command completes with **Check Condition** status then issue a *Request Sense (03)* command.
 - If the specified recovery procedure for the sense data is for a condition other than drive busy, follow the recovery procedure for the condition reported.
 - If the specified recovery procedure for the sense data is for a drive busy condition, and
 - If the drive is not busy for longer than the time specified in the *product Functional Specification*, test for busy again. This is not an error condition.
 - If the drive has been busy for longer than the limit specified in the *product Functional Specification*, then service the drive using the service guidelines recommended in C.1, “Drive service strategy” on page 279.
- If the *Test Unit Ready (00)* (or media access) command completes with **Good** status then return to normal processing.

C.4.2 Unrecovered drive error

The initiator should:

1. Retry the failing command.
2. If the retry of the failing command completes with
 - a. Good status or recovered sense key, follow the recovery procedure in C.4.3, “Recovered drive error.”
 - b. Hardware error sense, verify there is no outside cause (e.g. power supply) for the failure, then
 - 1) Retry the failing command.
 - 2) If the retry of the failing command completes with
 - a) Good status, follow the recovery procedure in C.4.3, “Recovered drive error.”
 - b) Recovered sense or Hardware error sense, then service the drive using the service guideline recommended in C.1, “Drive service strategy” on page 279.

C.4.3 Recovered drive error

The initiator should log the error as soft with the recovery level.

C.4.4 Drive not ready

The initiator should

1. Issue a *Start/Stop Unit (1B)* command.
2. Verify the drive comes ready within the time specified in the *product Functional Specification*.

If the drive fails to come ready within the specified time, service the drive using the service guidelines specified in C.1, “Drive service strategy” on page 279.
3. Retry the failing command.
4. If the failing command completes with
 - a. Good status, log the error as recovered.
 - b. Not Ready sense, verify there is no outside cause (e.g. power supply) then service the drive using the service guidelines specified in C.1, “Drive service strategy” on page 279.

C.4.5 No defect spare

Three conditions can exist that will cause this error. The three conditions are:

1. When the *Reassign Blocks (07)* command is issued and all the available spares on the cylinder with the sector in error and all the spares on the two subsequent cylinders are used. In this case, there are no spares available for the Drive to use for the relocation requested.
2. When last usable physical sector on a track is the sector being reassigned. This reassignment would make all the sectors on a track reassigned. The Drive requires at least one (1) usable sector on each track.
3. When the Glist is full and the sector to be reassigned cannot be added.

Service the Drive following the C.1, “Drive service strategy” on page 279.

C.4.6 Degraded Mode

Refer to 4.1.9, “Degraded Mode” on page 208 for the definition of this state. There are five (5) causes for entering degraded mode. In all cases the Sense Key is *Not Ready*. They are:

1. Sense Code/Qualifier of **Logical Unit Not Ready, initializing command required**. The spindle motor not spinning or not at the proper speed.

This may not be an error condition. The initiator should issue a *Start Unit (1B)* command to start the spindle motor.

If the Drive fails to come ready in the specified time (reference the *product Functional Specification*), service the drive using the service guideline recommended in C.1, “Drive service strategy” on page 279.

2. Sense Code/Qualifier of **Logical Unit Failed Self-Configuration**. File configuration record has not been read or is not readable This condition is the result of the configuration data located in the reserved area not being read because of an error in the configuration data records or an error prior to the process step that reads the configuration data. In either case, recovery requires the Drive to successfully read the configuration data. This can be done one of two (2) ways.

First, power may be cycled. This will initiate the power up process that includes reading in the configuration data. If the error that caused the configuration data to not be read occurs again, then the configuration data will not be loaded.

The second method to load configuration data is to execute a *Start Unit (1B)* command.

3. Sense Code/Qualifier of **Logical Unit Failed Self-Configuration**. RAM microcode not loaded. The RAM microcode is loaded as part of the spindle start up. If an error occurs during the spin up or as part of the test process after the motor has reached speed, then the RAM microcode may not be loaded.

Recovery for this step is the same as for the configuration data not being loaded. Either a power cycle or the successful completion of a *Start Unit (1B)* command will cause the Drive to attempt to load the RAM microcode.

In addition to the power cycle or *Start Unit (1B)* command, the initiator may attempt to load microcode (reference 1.34, “Write Buffer” on page 160).

4. Sense Code/Qualifier of **Diagnostic Failure**. Failure of a Send Diagnostic self test, a start up sequence, or other internal target failures
 - Failure of a send diagnostic self test or a start up sequence. This failure is the result of the diagnostics that are executed during power on or when the *Send Diagnostic (1D)* command is executed detecting a failure. As with the RAM code not loaded and the configuration data not loaded, the recovery is either a power cycle or issuing the *Send Diagnostic (1d)* command with the self test bit set active.
 - Recovery for a failed *Send Diagnostic (1D)* command is either:
 - a. Execute the *Send Diagnostic (1D)* command, or
 - b. Power cycle the drive.
 - If the failure repeats, service the drive using the service guideline recommended in C.1, “Drive service strategy” on page 279.

- Recovery for a failed power up sequence is either:
 - a. Issue a *Start Unit (1B)* command, or
 - b. Power cycle the drive.

If the failure repeats, service the drive using the service guideline recommended in C.1, “Drive service strategy” on page 279.

5. Sense Code/Qualifier of *Format Command Failed Format Unit (04)*, Sense Code/Qualifier of *Medium Format Corrupted Reassign Failed Reassign Blocks (07)* command, or an automatic reallocation failed or was abnormally terminated.

Recovery from a reassign degraded condition is to retry the failed *Reassign Blocks (07)* command (see C.3.4, “Reassign Blocks Recovery” on page 284). The sense data returned for a reassign degraded condition contains the LBA that was being reassigned in the command specific bytes.

Recovery from a failed *Format Unit (04)* command is to retry the command. If the command fails a second time, service the drive following the procedure defined in C.1, “Drive service strategy” on page 279.

If the above defined recovery procedures fail to clear the degraded mode condition, the the Drive should be replaced. Follow the procedure C.1, “Drive service strategy” on page 279 when replacing the drive.

C.4.7 Reserved Area Hard Error

Sectors found defective in the reserved area of the disk cannot be reassigned after the Drive leaves the factory. The data in the reserved area is not directly accessible by the initiator. For this reason, the reserved area has all data except the *Reassign Blocks (07)* command work area duplicated. A data error must occur in both copies of the data record before the Drive considers a reserved area read error. When this happens, the integrity of the drive is questionable.

Service the Drive using the C.1, “Drive service strategy” on page 279 procedure.

C.4.8 Interface Protocol

For all interface protocol errors, the initiator should:

1. Correct the parameter that caused the illegal request
2. Retry the failing command.
3. If the first retry of the failing command completes with
 - a. Good status, log the error as recovered
 - b. Check condition status with sense data for an illegal request, verify there is no outside cause (e.g. power supply) for the failure
 - c. Other, follow the recommendations for the error condition reported.
 - 1) Retry the failing command.
 - 2) If this retry of the failing command completes with
 - a) Good status, log the error as recovered
 - b) Check condition status with sense data for an illegal request, service the drive using the service guideline recommended in C.1, “Drive service strategy” on page 279.

- c) Other, follow the recommendations for the error condition reported.

Note: - During a microcode download, the Drive verifies the level of microcode being loaded with the level resident in ROS. If the two microcode levels are incompatible, the command terminates with check condition status and sense for illegal request and the additional sense code for invalid field in parameter list.

If all the command parameters are correct, the command is a *Write Buffer (3B)* command with a download or download and save microcode mode selected, and the additional sense code is 26, the cause of the illegal request may be an incompatible LID. To verify the LID is correct, the initiator should:

1. Issue an *Inquiry (12)* command with the EVPD option set to 1 and the identifier set to 03.
2. Determine the correct level of microcode from the inquiry data. Refer to 1.3, “Inquiry” on page 30 for the location of the LID.
3. Load the correct level of microcode to the drive using the *Write Buffer (3B)* command with the correct mode.
4. If the error repeats or the *Write Buffer (3B)* command fails to complete successfully, service the drive using the service guideline recommended in C.1, “Drive service strategy” on page 279.

C.4.9 Aborted Command

The initiator should determine the cause from the additional sense code (byte 12)

- Sense key = B (Aborted Command) with additional sense codes of 1B, 25, 43, 45, 49, and 4E and sense key = 5 (Illegal Request) with additional additional sense code of 3D are initiator caused abort conditions. The initiator should correct the condition that caused the abort and retry the failing command.
- Sense key = B (Aborted Command) with additional sense code of 44 or 48 are Drive caused abort conditions The initiator should:
 1. Retry the failing command.
 2. If the retry of the failing command completes with
 - a. Good status, log the error as recovered
 - b. Abort command sense, verify there is no outside cause (e.g. power supply) for the failure.
 3. Retry the failing command.
 4. If the retry of the failing command completes with
 - a. Good status, log the error as recovered
 - b. Abort command sense, then service the drive using the service guideline recommended in C.1, “Drive service strategy” on page 279.
- Sense key = B (Aborted Command) and an additional sense code of 47 can be an initiator or Drive caused abort condition. The initiator should follow the above procedure for initiator caused abort conditions if the Drive detected the SCSI bus parity error. The initiator should follow the above procedure for Drive caused abort conditions if the initiator detected the SCSI bus parity error.

C.4.10 Unit Attention

Unit Attention conditions are not errors. They alert the initiator that the Drive had an action that may have changed an initiator controlled state in the drive. These conditions are:

C.4.10.1 Not Ready to Ready Transition

Not ready to ready transition, unit formatted. This unit attention condition will not be reported to the initiator that issued the *Format Unit (04)* command.

C.4.10.2 Reset

Reset - This means the drive was reset by either a power-on reset, Bus reset, a Bus Device Reset message, or an internal reset.

C.4.10.3 Mode Parameters Changed

A *Mode Select (15)* command successfully completed - This means that the mode parameters that are the current value may have changed. The parameters may or may not have changed but the command to change the parameters successfully completed. The Drive does not actually compare the old current and the new current parameters to determine if the parameters changed. This unit attention condition will not be reported to the initiator that issued the *Mode Select (15)* command.

C.4.10.4 Microcode has Changed

Write Buffer (3B) command to download microcode has successfully completed. This means that the microcode that controls the Drive has been changed. The code may or may not be the same as the code resident on the media. The Drive does not compare old level code with new code.

C.4.10.5 Commands Cleared by Another Initiator

Tagged commands cleared by a clear queue message. This means that the command queue has been cleared. The unit attention condition is not reported to the initiator that issued the clear queue message. Unit attention condition is reported to all initiators that had commands active or queued.

Reissue any outstanding command.

C.4.10.6 Spindles Synchronized

Spindles synchronized - This means that the spindle of this Drive achieved synchronization with the spindle of another device. This unit attention condition is issued to all initiators including the initiator requesting spindle synchronization.

NOTE: If the saved mode parameters are for a synchronized mode, unit attention condition will not be reported when the spindle comes into synchronization from a start up sequence.

C.4.10.7 Spindles Not Synchronized

Spindles not synchronized - This means that the Drive's spindle was synchronized with another device and that synchronization is lost. The two conditions that will cause loss of spindle synchronization are a hardware fault or a *Start/Stop Unit (1B)* command with the mode parameter RPL bits changed to the no synchronization state (00). If the initiator requires spindle synchronization, recovery from loss of synchronization is the same for either cause.

The initiator should:

1. Issue a *Mode Select (15)* command, page 4, with the desired RPL mode bits and rotational offset selected.
2. Issue a *Start/Stop Unit (1B)* command with the start bit active.
3. Issue a *Test Unit Ready (00)* command followed by a *Request Sense (03)* command. If the *Test Unit Ready (00)* command or the *Request Sense (03)* command complete with sense for
 - Not ready, logical unit in process of becoming ready, verify that the attempt to achieve synchronization is still within the specified time limit (4.5, “Motor Synchronization” on page 225) then return to the beginning of this step.
 - Unit attention condition, spindles not synchronized, the loss of synchronization is probably caused by a *Start/Stop Unit (1B)* command with the RPL mode bits selected for no synchronization (00). Return to normal processing.
 - Unit attention condition, spindles not synchronized, a hardware fault is probably the cause of failure. Locate and correct the cause of loss of synchronization.
 - Good status with no sense data, this is an error condition. The Drive will report check condition status with sense data for a unit attention condition before good status is reported. If good status is reported before the unit attention condition, service the drive following the service guideline recommendations in C.1, “Drive service strategy” on page 279
 - Any other status and sense combination, follow the recommendations for the returned sense.

C.4.10.8 Log Select Parameters Changed

A Log Select (4C) command successfully completed - This means that the the Log Select command cleared statistical information successfully (See Log Select command). This unit attention condition is reported to all initiators excluding the initiator that issued the Log Select command.

C.4.11 Components Mismatch

A compatibility test is performed during BATS-2. The compatibility test verifies that the electronics assembly is compatible with the HDA. When the Drive detects a mismatch in the components, the most likely cause is the result of incorrect parts used during a service action.

If the error reported is

Key/code/qualifier 4/40/C0 - Diagnostic failure, Load IDs do not match on bring-up

The initiator should determine

1. The proper level of microcode from page 3 of the EVPD inquiry data. Refer to 1.3, “Inquiry” on page 30.
2. Load the proper level of microcode to the media using the *Write Buffer (3B)* command with the download and save option.

To load new microcode, the initiator should:

- a. Issue an *Inquiry (12)* command for EVPD page 3. EVPD page 3 of the inquiry data contains the valid LID.

- b. Issue a *Write Buffer (3B)* command with the download and save option. The microcode used during the data out phase should have the same LID as the LID reported in page 3 of the inquiry data.
 - c. If the *Write Buffer (3B)* command completes with:
 - GOOD status, continue to next step.
 - Check Condition status, service the drive using the service guidelines recommended in C.1, “Drive service strategy” on page 279.
3. Execute the *Send Diagnostic (1D)* command with the self test bit active.
 4. Check the send diagnostic end status. If the status is
 - GOOD, Return to normal processing.
 - CHECK CONDITION, issue a *Request Sense (03)* command and follow the recommendations for the sense data returned unless the sense data is for a component mismatch. If the sense data is for component mismatch, service the drive using the service guideline recommended in C.1, “Drive service strategy” on page 279.

Key/code/qualifier 4/40/D0 - Diagnostic failure, Electronics mismatch on bring-up.

The initiator should determine

1. The proper level of electronics from page 2 of the EVPD inquiry data. Refer to 1.3, “Inquiry” on page 30.
2. Replace the electronics with the correct part number electronics.
3. If bring-up complete status is
 - GOOD, Return to normal processing.
 - CHECK CONDITION, issue a *Request Sense (03)* command and follow the recommendations for the sense data returned unless the sense data is for a component mismatch. If the sense data is for component mismatch, service the drive using the service guideline recommended in C.1, “Drive service strategy” on page 279.

C.4.12 Self Initiated Reset

The Drive will initiate a self reset when the condition of the Drive cannot be determined. The internal reset will terminate any outstanding commands, release any reserved initiators, execute BATS, and stop the spindle motor. The initiator can recover by:

- Sense key = 2,
 1. Log the error
 2. Issue a *Start/Stop Unit (1B)* command
 3. Retry the failing command. If the failing command completes with
 - Good status, return to normal processing.

- Self initiated reset sense, service the drive following the guidelines recommended in C.1, “Drive service strategy” on page 279.
 - Other, follow the recommendations for the error reported.
- Sense key = 4,
 1. Log the error
 2. Retry the failing command. If the failing command completes with
 - Good status, return to normal processing.
 - Self initiated reset sense, service the drive following the guidelines recommended in C.1, “Drive service strategy” on page 279.
 - Other, follow the recommendations for the error reported.

C.4.13 Defect List Recovery

This is not an error condition.

The initiator either requested a defect list in a format (block or vendor specific) that the Drive does not support or the requested defect list(s) exceed the maximum list length that can be returned. If the sense key/code/qualifier are:

1/1F/00, the requested list(s) exceed the maximum length that can be supported. The initiator should request one list at a time. If a single list exceeds the maximum returnable length, this may be an indication of a marginally operational drive. Service the drive using following the service guidelines in C.1, “Drive service strategy” on page 279.

1/1C/01 or 1/1C/02, the requested defect list is not in the format that the Drive supports. The requested defect list is returned in the physical (cylinder, sector, head) format. This is the default format. There is no initiator action required for this condition.

C.4.14 Miscompare recovery

A miscompare can occur on a *Verify (2F)* command or a *Write and Verify (2E)* command with the byte check (BytChk) bit active. Recovery for a miscompare error is different for the two commands.

Verify command

The initiator should:

1. Verify that the data sent to the drive is the correct data for the byte-by-byte compare.
2. Read the data from the media with a *Read (08)* or *Read (28)* command and verify that the data from the media is the expected data for the byte-by-byte compare.
 - If all data are correct, this is an indication that the data may have been read from the media incorrectly without an error detected. Service the drive using the procedure specified in C.1, “Drive service strategy” on page 279.
 - If all data are not correct, this is an indication that the data on the media is not the data the initiator expected. Rewrite the correct data to the media.

Write and Verify command

The drive uses the same data in the data buffer to write then read and compare. A miscompare error on the *Write and Verify (2E)* command is an indication that the drive cannot reliability write or read the media. Service the drive using the procedures specified in C.1, “Drive service strategy” on page 279.

C.4.15 Microcode error

The microcode loaded from the media or from the interface is validated before the device operates using that microcode. When the validation detects incorrect or incomplete data, the Drive enters degraded mode.

If the initiator attempted to load microcode using the *Write Buffer (3B)* command, retry the *Write Buffer (3B)* command. If the command completes with

- Good status - return to normal processing
- Check condition status - service the drive using the service guidelines recommended in C.1, “Drive service strategy” on page 279.

If the check sum error occurred during normal processing, the initiator may attempt to load microcode to the media before deciding to service the drive using the service guidelines recommended in C.1, “Drive service strategy” on page 279.

To load new microcode, the initiator should:

1. Issue an *Inquiry (12)* command for EVPD page 3. EVPD page 3 of the inquiry data contains the valid LID.
2. Issue a *Write Buffer (3B)* command with the download and save option. The microcode used during the data out phase should have the same LID as the LID reported in page 3 of the inquiry data.
3. If the *Write Buffer (3B)* command completes with:
 - GOOD status - return to normal processingRetry the failing command. If the command complete with
 - Good status - Continue normal processing.
 - Check condition status for check sum error - Service the drive using the service guidelines recommended in C.1, “Drive service strategy” on page 279.
 - Check condition for any other error - follow the recommended recovery procedure for the error reported.
- Check Condition status for Check sum error, service the drive using the service guidelines recommended in C.1, “Drive service strategy” on page 279.
- Check condition status for any other error, follow the recommendations for the returned sense data.

C.4.16 Predictive failure analysis

The Drive performs error log analysis and will alert the initiator of a potential failure. The initiator should determine if this device is the only device with error activity.

If this drive is the only drive attached to the initiator with error activity, service the drive using the procedures specified in C.1, “Drive service strategy” on page 279. Note, service for this drive can be deferred. The longer service is deferred, the more probable a failure can occur that will require immediate service.

If more than this drive is experiencing error activity, the drive is probably not at fault. Locate and service the outside source causing error activity on this drive.

Appendix D. UEC List

Following is the list of Unit Error Codes and associated descriptions. The Unit Error Codes are returned by the target in sense data bytes 20-21 in response to the Request Sense command.

Note: The list of Unit Error Codes and descriptions does not have a direct correlation to the error descriptions and Sense Key/Code/Qualifier descriptions in Appendix A, “SCSI Sense Data Format” on page 247.

Table 175 (Page 1 of 8). Unit Error Codes with Descriptions.	
Unit Error Code	Description
00 00	No error.
01 01	Degraded Mode/Motor not running.
01 02	Unavailable while Start Motor active.
01 03	Unavailable while Spinup active.
01 04	Unavailable while Format active.
01 05	Synchronous transfer error, Extra pulses on synchronous transfer.
01 06	Requested P List does not match returned list format (READ DEFECT DATA only)
01 07	Requested G List does not match returned list format. (READ DEFECT DATA only)
01 08	Defect List Error prevented one or more defects from being used in a format Unit command or from being reported in a Read Defect Data command.
01 0A	Defect list longer than 64k, 64k of data returned. (READ DEFECT DATA only)
01 0B	BATS#2 Error. Track Personalization Memory(TPM) Error.
01 10	Too few valid GEM measurements available to perform a GEM Predictive Failure Analysis.
01 11	Degraded Mode/Reassign Block unsuccessful after pushdown started.
01 12	Degraded Mode/Format unsuccessful.
01 13	Degraded Mode/Configuration not loaded.
01 14	Degraded Mode/RAM Microcode not loaded.
01 15	Degraded Mode/RAM Microcode not loaded, Download incomplete.
01 16	ROS Microcode Download Failed.
01 1B	Motor Start Failed due to Timer 1 being disabled.
01 1C	Command not allowed while in Write Protect Mode.
01 1D	Required disconnection was not allowed.
01 1E	A CIOP message was received on an initial connection. (Bus Free)
01 1F	Mismatch between the Servo Processor and the Reference Track Image.

Table 175 (Page 2 of 8). Unit Error Codes with Descriptions.	
Unit Error Code	Description
01 20	Microcode Check Sum error detected during download of Microcode.
01 21	Mismatch between the Interface Processor ROS and Servo Processor ROS.
01 22	Degraded Mode/Bringup not successful.
01 23	Failure to load Servo Microcode into RAM.
01 24	Mismatch between the Servo Processor ROS and DE.
01 25	Mismatch between the Servo Processor ROS and Interface Processor RAM.
01 26	Mismatch between the Interface Processor RAM and DE.
01 27	Buffer Controller Chip Channel A Error - Parity error during transfer in.
01 28	Buffer Controller Chip Channel A Error - Parity error during transfer out.
01 29	Buffer Controller Chip Channel A Error - Programmed IO Parity error.
01 2A	Buffer Controller Chip Channel A Error - Unexpected error.
01 2B	Command aborted due to Fatal Hardware error.
01 2C	SCSI Controller Chip internal parity error.
01 2D	Cannot resume the operation (Data transfer).
01 2E	Mismatch between the Interface Processor ROS and RAM.
01 2F	Mismatch between the Interface Processor ROS and the DE.
01 30	Invalid Op. code.
01 31	Invalid LBA.
01 32	CDB Invalid.
01 33	Invalid LUN.
01 34	Command parameter data invalid.
01 35	Command parameter list length error.
01 36	Microcode and Load ID mismatch during Write Buffer Command.
01 37	Data length error on Read Long or Write Long.
01 38	Invalid field in Parameter Data, See Field Pointer Value.
01 39	Invalid LBA in Reassign Command when Reassign degraded.
01 3A	Invalid Buffer ID in Write Buffer Command.
01 3B	Microcode and Servo Processor ROS mismatch during Write Buffer Command.
01 3C	Microcode and DE mismatch during Write Buffer Command.
01 3D	Microcode and Interface Processor ROS mismatch during Write Buffer Command.

Table 175 (Page 3 of 8). Unit Error Codes with Descriptions.	
Unit Error Code	Description
01 3E	Microcode and Interface Processor RAM mismatch during Write Buffer Command.
01 3F	SCSI Controller Chip detected an LRC error during read.
01 40	Unit Attention/Not Ready to Ready Transition(Format Completed)
01 41	Unit Attention/POR.
01 42	Unit Attention/Mode Select Parameters have changed.
01 43	Unit Attention/Write Buffer.
01 44	Unit Attention/Command cleared by another initiator.
01 45	Unit Attention/Self Initiated Reset.
01 47	Unit Attention/Spindles not Synchronized.
01 48	Unit Attention/Spindles Synchronized
01 49	Unit Attention/Log Parameters Changed
01 50	Microcode Check Sum error detected during ROS Test.
01 51	Microcode Check Sum error detected during RAM Test.
01 52	Microcode Check Sum error detected during upload of Microcode.
01 53	Motor Synchronization lost, motor speed maintained.
01 56	GLIST full. Cannot add more entries.
01 57	Entire track of defective sectors.
01 58	No sector pulse found.
01 59	Defect list update failure.
01 5A	Motor is Stuck, Cannot be started.
01 5C	Reassign could not find the target LBA.
01 5D	No Sector Found caused by hardware fault or software.
01 5E	No spare sectors remaining.
01 5F	Error in Primary Defect list.
01 60	Initiator Detected Error for other than STATUS or linked COMMAND COMPLETE phase.
01 61	Unrecovered SCSI parity error detected by Target during a command or data phase.
01 62	Invalid Initiator Connection.
01 63	Media Problem, Recommend Device Replacement
01 64	Hardware Problem, Recommend Device Replacement
01 65	Error in Primary Defect list (READ DEFECT DATA only)
01 66	Error in Grown Defect list (READ DEFECT DATA only)
01 6A	Servo Error; Invalid Servo Status Received by the Interface Processor
01 6B	Arm Electronics Not Ready.
01 6C	Sanity Error during Read Capacity execution.
01 6D	Target unexpectedly went Bus Free. (Bus Free)
01 6E	Servo Data not present in CSR.

Table 175 (Page 4 of 8). Unit Error Codes with Descriptions.	
Unit Error Code	Description
01 6F	Servo Data Verify Failure.
01 70	Abort Message received; (Bus Free)
01 71	Different LUN addressed (Identify message) from first selected. (Bus Free)
01 72	Innapropriate Message Reject message received. (Bus Free)
01 73	Reselection timeout. (Bus Free)
01 74	Unrecovered SCSI parity error detected by the Target during a MESSAGE OUT phase. (Bus Free)
01 75	Initiator Detected Error message for STATUS or Linked COMMAND COMPLETE phase. (Bus Free)
01 76	Invalid message or attention dropped before all bytes of an extended message are transferred. (Bus Free)
01 77	Attention dropped too late. (Bus Free)
01 78	Message parity error received when no message sent by Target. (Bus Free)
01 79	Reserved bits in Identify message are non zero. (Bus Free)
01 7A	Unrecovered SCSI parity error detected by the Initiator (Message Parity Error Message). (Bus Free)
01 7B	SCSI interrupt invalid. (Bus Free)
01 80	SP interrupt on but SP Status Valid bit is off.
01 81	Error in Grown Defect list (used by Format Unit and Reassign Block commands).
01 82	Format Track parameter error (number of sectors and number of ID's do not match).
01 83	Seek positioning error (ID miscompare).
01 84	Invalid SP Command Sequence.
01 85	Illegal Head or Cylinder requested.
01 86	A servo command is already active.
01 87	Interface Processor detected Servo Sanity Error
01 88	Controller/Channel Hardware detected Servo Sanity Error
01 89	Reserved area sector valid check failed.
01 8A	Servo processor did not finish command in time.
01 8B	Motor timeout error.
01 8C	Configuration Sector valid check failed.
01 8D	Configuration Sector uploaded but Check Sum error.
01 8E	Reserved area sector version check failed.
01 8F	Buffer too small to do a requested function.
01 90	Self Init Reset, W/O Auto Motor Start - Invalid Input
01 90	Self Init Reset, W Auto Motor Start - Invalid Input
01 91	Track characterization failure. Unable to determine sector LBA due to adjacent read ID failures, with one sector defective. Reassign(pushdown not started) or Log Sense.
01 92	Miscompare during byte by byte verify.

Table 175 (Page 5 of 8). Unit Error Codes with Descriptions.	
Unit Error Code	Description
01 93	BATS#2 Error. Read write test failure.
01 94	BATS#2 Error. ECC/CRC test failure.
01 95	BATS#2 Error; Seek test failure.
01 96	BATS#2 Error; Head Offset Test failure.
01 97	Self Init Reset, W/O Auto Motor Start - No task available
01 97	Self Init Reset, W Auto Motor Start - No task available.
01 98	Self Init Reset, W/O Auto Motor Start - Cause Unknown
01 98	Self Init Reset, W Auto Motor Start - Cause Unknown
01 99	Self Init Reset, W/O Auto Motor Start - SCSI Controller Chip Reset unsuccessful
01 99	Self Init Reset, W Auto Motor Start - SCSI Controller Chip Reset unsuccessful
01 9A	Self Init Reset, W/O Auto Motor Start - Buffer Controller Chip Reset unsuccessful
01 9A	Self Init Reset, W Auto Motor Start - Buffer Controller Chip Reset unsuccessful
01 9B	Self Init Reset, W/O Auto Motor Start - Zero Divide Error
01 9B	Self Init Reset, W Auto Motor Start - Zero Divide Error
01 9C	Self Init Reset, W/O Auto Motor Start - Control Store Address Fault
01 9C	Self Init Reset, W Auto Motor Start - Control Store Address Fault.
01 9D	Self Init Reset, W/O Auto Motor Start - Unused Op Code
01 9D	Self Init Reset, W Auto Motor Start - Unused OP Code
01 9E	Motor Thermal Shutdown
01 9F	Self Init Reset, W/O Auto Motor Start - Invalid Queue Operation
01 9F	Self Init Reset, W Auto Motor Start - Invalid Queue Operation
01 A0	Servo error; Command not accepted while NOT in Retract.
01 A1	Servo error; Loss of interrupts from the Controller/Channel Hardware.
01 A2	Servo error; Settle timeout.
01 A3	Servo error; Coarse offtrack.
01 A4	Servo error; Three consecutive missing Servo IDs detected by Servo Processor
01 A5	Servo error; Unexpected Guardband detected.
01 A6	Servo error; Settle overshoot.
01 A7	Servo error; Seek timeout.
01 A8	Servo error; Target Cylinder out of Range.
01 A9	Servo error; Command not accepted while in Retract.
01 AA	Servo Error; Invalid velocity detected during seek.
01 AB	Servo error; Maximum seek velocity exceeded.

Table 175 (Page 6 of 8). Unit Error Codes with Descriptions.	
Unit Error Code	Description
01 AC	Servo error; Head number out of range.
01 AE	Servo error; Invalid Command.
01 AF	Servo error; Velocity too high at settle hand off.
01 B0	Servo error; Offset out of range.
01 B1	Servo error; Recalibrate Breakaway Failed - ID Guarband seen.
01 B2	Servo error; Recalibrate Breakaway Failed - Data Band seen.
01 B3	Servo error; Recalibrate Breakaway Failed - ID and Data band seen.
01 B4	Servo error; Recalibrate Breakaway Failed - ID and Data band not seen.
01 B5	Servo error; Recalibrate State 2 timeout - Cylinder -8 not found.
01 B7	Servo error; Recalibrate State 4 timeout - Data Band Cylinder 0 not found.
01 B8	Servo error; Loss of interrupts - motor start bit not active.
01 B9	Servo error; Loss of interrupts - Servo Processor Lost.
01 BA	Servo error; Loss of interrupts - Interface Processor initiated retract.
01 BB	Servo error; Loss of interrupts - Servo Processor initiated retract.
01 BC	Servo error; Loss of interrupts - Controller/Channel Hardware reset.
01 BD	Servo error; Loss of interrupts - Bad Coherence.
01 BE	Servo error; Loss of interrupts - Conversion Too Long.
01 C0	Too many missing Servo IDs detected by Controller/Channel Hardware
01 C1	Arm Electronics error.
01 C2	Fake and Extra Index.
01 C3	SP lost.
01 C4	Sector overrun error.
01 C5	Interface Processor write inhibit error.
01 C7	Microjog Write Inhibit
01 C8	Interrupt Occured with no interrupt bits set.
01 C9	Write with No Sector Pulses.
01 CB	Motor Speed Error.
01 CC	Channel module Register Write Error
01 CD	IP Retract Error
01 CE	Temporary loss of Motor Synchronization.
01 D0	No sector found error (ID no sync. found).
01 D1	No Data sync. found.
01 D2	Data ECC Check

Table 175 (Page 7 of 8). Unit Error Codes with Descriptions.	
Unit Error Code	Description
01 D3	Data correction applied to Drive data for a Data ECC check.
01 D4	ECC check corrected without using ECC correction.
01 D5	Data Sync error detected while outside of the write band.
01 D6	Data ECC Check detected while outside of the write band.
01 D7	ECC Error Detected while outside of write band corrected with ECC.
01 D8	ECC Error Detected while outside of write band corrected without ECC.
01 D9	Data recovered using positive offsets.
01 DA	Data recovered using negative offsets.
01 DB	Data recovered using No ID Recovery
01 DC	Unrecovered Verify Error with BytChk Option before ECC check.
01 DE	Recovered Verify Error with BytChk Option without ECC correction.
01 E0	Servo error; Loss of interrupts - No SID signal.
01 E2	Servo error; Servo Nonvolatile Storage RAM error - Command not allowed while NVSRAM not loaded.
01 E3	Servo error; Coarse offtrack - Recalibrate State 1.
01 E4	Servo error; Coarse offtrack - Recalibrate State 2.
01 E5	Servo error; Coarse offtrack - Recalibrate State 3.
01 E6	Servo error; Coarse offtrack - Recalibrate Step 4.
01 E8	Servo error; Recalibrate State A timeout - No OD Guardband.
01 E9	Servo error; 3 Bad Servo ID's - Recalibrate State 1.
01 EA	Servo error; 3 Bad Servo ID's - Recalibrate State 2.
01 EB	Servo error; 3 Bad Servo ID's - Recalibrate State 3.
01 EC	Servo error; 3 Bad Servo ID's - Recalibrate State 4.
01 ED	Servo error; Recalibrate State B timeout - No OD Guardband.
01 F0	Buffer Controller Chip Sequencer Error - Check Sum error when loading
01 F1	Buffer Controller Chip Sequencer Error - Not stopped when loading.
01 F2	Buffer Controller Chip Error - Invalid interrupt error.
01 F3	Buffer Controller Chip Error - Invalid read SEQSTOP.
01 F6	Write/Read Gate not detected during operation.
01 F8	Buffer Controller Chip Error - Channel parity error on read.
01 F9	Buffer Controller Chip Error - Channel parity error on write.
01 FB	Buffer Controller Chip Error - Channel B was busy before the start of a data transfer.

Table 175 (Page 8 of 8). Unit Error Codes with Descriptions.	
Unit Error Code	Description
01 FC	Buffer Controller Chip Error - Channel error during a transfer from the Data buffer to the Control Store RAM (CSR)
01 FD	Buffer Controller Chip Error - Channel error during a transfer from the Control Store RAM to the Data Buffer
02 00	Buffer Controller Chip Error - ECC On The Fly timeout
02 01	Buffer Controller Chip Error - Pipeline already full
02 02	Buffer Controller Chip Error - FIFO overrun/underun
02 03	Disk Manager Chip detected an LRC error during write.
02 10	Channel Module Write Parity Error
02 11	Channel Module Read Parity Error
02 13	Data Manager Write Parity Error
02 15	Track Personalization Memory(TPM) Error
02 16	Servo ID overrun Error
02 17	Channel Module Write Unlock Error
02 18	Arm Electronics(AE) Idle Error
02 19	Interface Processor Ready Timeout Error
02 1A	Address Mark Enable(AMENA) After Sync.
02 1B	External Write Inhibit.
02 20	Channel Noise Problem, Recommend Device Replacement
02 21	Channel Assymetry Problem, Recommend Device Replacement
02 22	Channel Precompensation Problem, Recommend Device Replacement
02 23	Channel DC Offset Problem, Recommend Device Replacement
02 24	Channel Timing Offset Problem, Recommend Device Replacement
02 25	Fly Height Change Problem, Recommend Device Replacement
02 26	Torque Amplification Problem, Recommend Device Replacement
02 27	ECC On The Fly Hardware Problem, Recommend Device Replacement
02 30	BATS#2 Error. LRC test failure.
02 31	BATS#2 Error. Palette RAM test failure.
02 32	BATS#2 Error. Digital Filter RAM test failure.
4x xx	Thermal Asperity Detected during error.
8x xx	Invalid UEC - x xx is Invalid UEC.

Glossary

Active I/O process. An I/O process which is executing (not queued).

Active LUN condition. Under certain Target conditions a LUN is active to all Initiators without a command being in progress (that is, without status being outstanding for a command). The Active LUN condition is initiated by either an internal Target action (internally initiated) or a command that was received from an Initiator (externally initiated).

Cache. A storage area where data can be retrieved from faster than from the main storage area. The cache contains copies of parts of the main storage.

Command queue. The queue in which processes are queued for execution in the target. The **head of the queue** refers to the next queued I/O process to be executed. The **tail of the queue** refers to the process that will be the last process to be executed.

Current I/O process. The I/O process which is currently connected to SCSI Bus.

Dequeuing. The removal of a queued I/O process from the command queue. The queued I/O process thus removed becomes the active I/O process.

DRP. Data Recovery Procedure for:

- No Data Sync Byte
- Data ECC Check
- No Sector Found errors on read commands.

ERP. Error Recovery Procedures. ERP errors fall into 4 classes:

- Drive Fault
- Position (Servo)
- Spindle Motor
- Spindle Synchronization Errors.

Enqueuing. The placing, by the target, of the current I/O process into the command queue.

FRU. Field Replaceable Unit. Refers to any part of the file that can be separately replaced in the field.

I/O process. A target process started by an initiator selecting the target. A CDB may or may not have been transferred. If a CDB is transferred, the I/O process persists until the CDB execution is complete or the I/O process has been abnormally terminated. Multiple linked commands are considered to be a single I/O process. If a CDB is not transferred, the I/O process is considered complete at the next BUS FREE phase.

I_T_L nexus. The combination of *Initiator*, *Target*, and *LUN* that uniquely identifies an *untagged I/O*

process. The *I_T_L nexus* is established by a connection or reconnection that has an *Identify* message associated with it but no *Queue Tag* message.

Note: The term *I_T_L nexus* is also used to describe the entire class of *I_T_L_Q nexus* I/O processes which have the same I, T, and L values.

I_T_L_Q nexus. The combination of *Initiator*, *Target*, *LUN*, and *Queue Tag* that uniquely identifies a tagged I/O process. The *I_T_L_Q nexus* is established by a connection or reconnection that has both an *Identify* and a *Queue Tag* message associated with it.

LRC. Longitudinal Redundancy Code. An error detecting code that detects data buffer address faults and ensures large block coherency.

PFA. Predictive Failure Analysis. The process by which a condition is detected that could possibly cause a failure in the future, thereby allowing the replacement of the FRU prior to failure.

POR. Power On Reset

PRDF. Partial Response Digital Filter detection scheme. This hardware is used to detect the data coming off a magnetic disk.

Pre-Fetch.

1. A command where the Initiator informs the Target that it should read data into its cache storage. The Initiator may issue such a command if it knows it will request this data in the near future, but it is not currently ready for it.
2. An operation where the Target automatically reads data into its cache in anticipation of a future request by an Initiator.

Queue tag. The value associated with an I/O process that uniquely identifies it from other tagged I/O processes on the same logical unit for the same initiator.

Queue tag message. A Simple Queue Tag, Ordered Queue Tag, or Head of Queue Tag message.

Queued I/O process. An I/O process that is in the command queue but has not yet begun execution. A queued I/O process can't be the *active* I/O process.

Read Ahead. An operation where the Target continues reading beyond what was requested by the Initiator in anticipation that the Initiator will request the next sequential data soon.

Read Retention. A process where data just read is saved in a cache storage in anticipation that an Initiator will request that the data be read again soon.

Tagged I/O process. An I/O process which has a *Queue Tag* associated with it.

Thermal Asperity Event. A media error associated with the head/disk interface used in the target. The target

contains special circuitry to compensate and recover from Thermal Asperity Events.

Untagged I/O process. An I/O process which *does not* have a *Queue Tag* associated with it.

Index

A

- Abort message 169
- Abort Tag message 171
- Aborted Command* sense key 249
- active LUN condition 303
- Actual Retry Count bytes 269
- additional length 35, 36, 38, 42
- additional sense code 249
- additional sense code qualifier 249
- additional sense code qualifier byte 12 and 13 249
- additional sense length 249
- allocation length 35, 36, 38, 42
 - ASCII (American Standard Code for Information Interchange) 42, 43
- ASCII data 6
- attention condition 182
- automatic block reassignment 228
- automatic read reallocation enabled (ARRE) 83
- automatic write reallocation enabled (AWRE) 83

B

- block reassignment, automatic 228
- bring-up sequence 243
- buffer ratios, choosing 92
- Bus Device Reset message 171
- busy status 165

C

Caching

- Controls
 - Demand Read Retention Priority 231, 232, 237, 238
 - Disable Pre-Fetch Transfer Length 231, 232
 - DPO: Disable Page Out 231, 237, 238
 - FUA: Force Unit Access 231
 - Maximum Pre-Fetch 231, 232
 - Maximum Pre-Fetch Ceiling 231, 232
 - MF: Multiplication Factor 231, 232
 - Minimum Pre-Fetch 231
 - Number of Cache Segments 231
 - RCD: Read Cache Disable 231, 232, 236
 - Write Retention Priority 231, 237

- Caching parameters 102
- check condition status 165
- Clear Queue message 171
- command aging enable 79
- command queuing 221
- condition met status 165
- condition, deferred error 207
- condition, Internal Error 206
- configuration information 245

- Continue I/O Process message 172
- control 105

D

- DASD (Direct Access Storage Device) 35, 36, 38, 42
- data in phase retry 195
- data out phase retry 195
- data phase save data pointer 79
- defect map, grown 245
- deferred error condition 207
- Definition of Terms 303
 - degraded mode. 208
- disable correction (DCR) 85
- Disable ECC On The Fly 78
- disable page out (DPO) 122
- Disable Physical Writes 76
- disable target initiated synchronous negotiation 79
- disable transfer on error (DTE) 85
- Disconnect message 169
- disconnect permission 239
- disconnect/reconnect parameters 91
 - download and save 42
- download microcode 160
- Drive Microcode 245

E

- EBCDIC (Extended Binary-Coded Decimal Interchange Code) 36, 43
- enable early recovery (ERR) 85
- enable vital product data (EVPD) 30, 35, 36, 38, 40, 41, 42
- end inquiry command 42
- end inquiry command EVPD = 1 42
- end SCSI sense data 271
- end SCSI sense data description 271
- error correction code (ECC) 154
- error logs 228, 245
- error recovery procedures (ERP) 121
- error reporting, priority of 278
- European Computer Manufacturers Association (ECMA) 33
- exiting degraded mode 217
- extended message table 176, 179
- Extended messages 175

F

- flag and link bits 22
- flags 245
- force unit access (FUA) 122
- format and reassign degraded disable 79
- format in progress 270

Format Unit command 23

G

GList 23, 245
good status 165
grown defect map 245

H

Hardware Error sense key 248
Head of Queue Tag message 173
hex values 6

I

Identify message 174
identify message in phase retry 196
Illegal Request sense key 249
Immed bit 26
immed *Not Ready*, 270
incorrect initiator connection 199
Initiator Data Transfer Mode parameters 240
Initiator Detected Error message 169
Initiator Mode Select/Mode Sense parameters 240
Initiator selection, single 239
Initiator sense data 240
Initiator systems, multiple 240
Inquiry command 30
inquiry command EVPD = 1 page code = 01 36
inquiry command EVPD = 1 page code = 02 38
inquiry command EVPD = 1 page code = 03 40
inquiry command EVPD = 1 page code = 80 41
inquiry command EVPD = 1 page code = 82 42
inquiry data format 32
inquiry data format - EVPD = 1 page code = 01 36
inquiry data format download and save 42
inquiry data format EVPD = 1 page code = 82 42
inquiry data format EVPD = 1 36, 38, 42, 43
inquiry data format EVPD = 1 page code = 02 38
inquiry data format EVPD = 1 Page Code = 03 40
inquiry data format EVPD = 1 Page Code = 80 41
Interleave factor 23
intermediate/condition met 166
intermediate/good status 166
internal error condition 206
invalid LUN processing 198

L

LED pin 77, 241
Limit Idle Time Function 80
link and flag bits 22
Linked Command Complete message 170
Linked Command Complete with Flag message 171
logical block address (LBA) 125, 249
logical unit number (LUN) 36
LUN (logical unit number) 30, 139, 198

LUN processing, invalid 198

M

manufacturing SAT map (PList) 245
Medium Error sense key 248
Message Parity Error message 170
Message Reject during Target disconnection 182
Message Reject message 170
microcode, download 160
Mode Select (6) 70
Mode Select command 70
Mode Sense (6) 109
Mode Sense command 109
Mode Sense data format 111
multiple Initiator systems 240

N

No Operation message 170
No Sense sense key 248
non-arbitrating systems 239
Not Ready sense key 248

O

option pin 241
Ordered Queue Tag message 174

P

partial medium indicator (PMI) 125
PC meaning 109
peripheral device type 42
physical block address 270
PList 23, 245
post error (PER) 85
power-on reset 242
power-on self test 245
power-up sequence 243
Pre-Fetch command 119
predictive failure analysis errors, reporting of (RPFAE) 77
priority commands 220
priority of error reporting 278
progress indication bytes 270
protocol, SCSI 197

Q

qualify post error 75
queue full status 166
queue tag message table 173
Queue Tag messages 173
queuing, command 221

R

- RAM code revision level 34
- ratios, buffer 92
- read (10) 122
- read (6) 121
- Read Buffer command 123
- read cache disable (RCD) 103
- Read Capacity command 125
- Read command 91, 121
- read continuous (RC) 84
- Read Defect Data command 126, 129
- Read Extended command 122
- Read Long command 132
- Read-Ahead Function 231
- Reassign Blocks command 133
- reassignment, automatic block 228
- Receive Diagnostic Results command 135
- reconnecting to Read command 91
- reconnecting to Write command 92
- Recovered Error* sense key 248
- Release (6) command 137, 138
- removable media bit (RMB) 33
- Report Recovered Non Data Errors 78
- Request Sense command 139
- reselection timeout 239
- reservation conflict status 166
- Reserve (10) command 142
- Reserve (6) command 141
- reserved area 245
- reset actions 242
- reset condition 242
- reset sources 242
- Restore Pointers message 168
- retry 269
- Rezero Unit command 144
- ROM code revision level 34

S

- SAT map, manufacturing 245
- Save Data Pointer message 76, 168
- scratch areas for reassignment 245
- SCSI bus device reset message 242
- SCSI bus reset 242
- SCSI commands 21
- SCSI protocol 197
- SCSI sense data description 248
- SCSI sense data description Actual Retry Count bytes 269
- SCSI sense data description byte 1 248
- SCSI sense data description byte 12 250
- SCSI sense data description byte 14 269
- SCSI sense data description byte 15 - 16 269
- SCSI sense data description byte 18 - 19 270
- SCSI sense data description byte 2 248
- SCSI sense data description byte 24 - 29 271
- SCSI sense data description byte 3 - 6 249

- SCSI sense data description byte 30 - 31 271
- SCSI sense data description byte 7 250
- SCSI sense data description byte 8 - 11 250
- SCSI sense data description progress indication bytes 270
- SCSI sense data format 247
- SCSI status byte reporting, priority of 197
- seek (10) 145
- Seek (6) 145
- Seek command 145
- Seek Extended command 145
- selection without ATN 239
- self-initiated reset 242
- Send Diagnostic command 146
- sense data description 249
- sense data format 247
- sense key specific bytes 269
- sense key specific bytes (SKSV) 269
- sense keys 248, 249
- sense keys *Aborted Command* 249
- sense keys additional sense code 250
- sense keys additional sense length 250
- sense keys *Hardware Error* 248, 249
- sense keys *Illegal Request* 249
- sense keys *Medium Error* 248, 249
- sense keys *Miscompare* 249
- sense keys *No Sense* 248
- sense keys not implemented 249
- sense keys *Not Ready* 248
- sense keys *Recovered Error* 248
- sense keys *Unit Attention* 249
- Simple Queue Tag message 173
- simple queue tag message in phase retry 196
- single Initiator selection 239
- spin-up 243
 - start commands log sense 44, 52
 - start log sense 44, 52
 - start SCSI sense data 247
 - start SCSI sense data description 248
- start-up sequence 243
- Start/Stop Unit command 150
- Status Byte 165
- status byte reporting, priority of SCSI 197
- status phase retry 195
- summary of SCSI commands 21
- supported message functions 181
- supported messages, single byte 167
- Synchronize Cache command 152
- Synchronous Data Transfer Request message 175
- systems, non-arbitrating 239

T

- Target Transfer Disable message 172
- Test Unit Ready command 153
- timeout, reselection 239
- track compensation control 79
- transfer block (TB) 84

U

Unit Attention condition 202
Unit Attention sense key 249
Unit Error Code (UEC) 270

V

vendor unique 42
Verify command 154
vital product data (VPD) 35, 36, 38, 42

W

Wide Data Transfer Request message 179
write (10) 157
write (6) 156
Write and Verify command 158
Write Buffer command 160
Write Caching Function 235
Write command 92, 156
Write Extended command 157
Write Long command 163
write protect enable 72
Write Same command 164

Table Definitions

<u>id</u>	<u>File</u>	<u>Page</u>	<u>References</u>
THEAD	SPECTBLS	1	
THEAD2	SPECTBLS	1	
THEAD3	SPECTBLS	1	
THEADX	SPECTBLS	1	23, 24, 25, 27, 28, 30, 32, 35, 36, 38, 40, 41, 42, 44, 47, 47, 47, 48, 48, 48, 48, 48, 48, 48, 49, 49, 49, 49, 49, 50, 50, 50, 50, 50, 51, 51, 51, 52, 55, 56, 56, 56, 57, 57, 57, 57, 58, 58, 58, 58, 59, 59, 59, 59, 60, 60, 60, 60, 61, 61, 61, 62, 65, 66, 67, 67, 69, 70, 72, 73, 74, 75, 83, 91, 94, 97, 100, 102, 105, 107, 109, 111, 111, 113, 113, 114, 115, 116, 116, 117, 117, 118, 119, 121, 122, 123, 125, 125, 126, 127, 127, 128, 128, 129, 130, 130, 131, 131, 132, 133, 134, 134, 134, 135, 135, 136, 137, 138, 139, 141, 142, 144, 145, 145, 146, 148, 148, 150, 152, 153, 154, 156, 157, 158, 160, 163, 164, 165, 174, 247, 269, 269, 270
TBLX8	SPECTBLS	1	1, 1, 1, 1
TBLX8X	SPECTBLS	1	25, 32
TBLNO	SPECTBLS	1	1
TBLR2	SPECTBLS	1	
TBLR2R	SPECTBLS	1	
TBLR2RR	SPECTBLS	1	
PADFOOT	SPECTBLS	1	32
TBLHD	SPECTBLS	1	
TBLXX	SPECTBLS	1	23, 23, 23, 25, 25, 25, 25, 28, 28, 28, 28, 28, 28, 30, 30, 32, 32, 35, 36, 38, 40, 41, 42, 44, 44, 47, 47, 47, 47, 47, 47, 48, 48, 48, 48, 48, 48, 48, 48, 48, 48, 48, 49, 49, 49, 49, 49, 49, 49, 49, 49, 50, 50, 50, 50, 50, 50, 50, 50, 50, 51, 51, 51, 51, 51, 51, 51, 51, 51, 51, 52, 52, 52, 55, 56, 56, 56, 56, 56, 56, 57, 57, 57, 57, 57, 57, 57, 57, 58, 58, 58, 58, 58, 58, 58, 59, 59, 59, 59, 59, 59, 59, 59, 60, 60, 60, 60, 60, 60, 60, 61, 61, 61, 61, 61, 61, 61, 61, 62, 62, 62, 62, 65, 65, 65, 66, 66, 67, 67, 67, 67, 67, 69, 69, 69, 69, 70, 70, 72, 72, 73, 74, 75, 75, 75, 75, 75, 75, 75, 75, 83, 83, 91, 91, 91, 94, 94, 97, 97, 97, 100, 100, 102, 102, 102, 105, 105, 107, 107, 109, 109, 111, 111, 111, 113, 113, 113, 113, 113, 113, 113, 113, 113, 113, 113, 113, 114, 114, 114, 115, 115, 116, 116, 116, 116, 116, 117, 117, 117, 117, 117, 118, 118, 119, 119, 121, 121, 122, 122, 123, 123, 125, 125, 125, 126, 126, 127, 127, 127, 128, 128, 128, 128, 128, 128, 129, 129, 129, 129, 129, 130, 130, 130, 130, 130, 130, 131, 131, 131, 131, 131, 132, 132, 133, 133, 134, 134, 134, 134, 135, 135, 135, 135, 135, 135, 135, 136, 136, 136, 136, 137, 137, 138, 138, 139, 139, 141, 141, 142, 142, 144, 144, 145, 145, 145, 145, 146, 146, 148, 148, 148, 148, 148, 148, 150, 150, 152, 152, 153, 153, 154, 154, 156, 156, 157, 157, 158, 158, 160, 160, 163, 163, 164, 164, 174, 174, 247, 247, 247, 269, 269, 270
TBLXV	SPECTBLS	1	
TBLXXH	SPECTBLS	1	
TBLYY	SPECTBLS	1	
TBL1	SPECTBLS	1	
TBL2	SPECTBLS	1	32, 35, 36, 38, 40, 41, 42, 125, 126, 133, 135, 139, 144, 145, 153
TBL2X	SPECTBLS	1	121, 145, 156
TBL3	SPECTBLS	1	23, 30, 44, 52, 70, 109, 119, 121, 122, 123, 125, 126, 129, 132, 133, 135, 137, 138, 139, 141, 142, 144, 145, 145, 146, 150, 152, 153, 154, 156, 157, 158, 160, 163, 164
TBL31	SPECTBLS	1	
TBL4	SPECTBLS	1	23, 126, 127, 129, 130

TBL5	SPECTBLS	1	105, 117, 125
TBL6	SPECTBLS	1	
TBL7	SPECTBLS	1	30, 150, 163
TBL7X	SPECTBLS	1	165
TBL8	SPECTBLS	1	70, 137, 138, 141, 142
TBL9	SPECTBLS	1	44, 47, 48, 49, 50, 51, 52, 55, 56, 57, 58, 60, 61, 62, 65, 67, 69, 109
TBL9X	SPECTBLS	1	32
TBL10	SPECTBLS	1	32, 247, 247, 269, 269
TBL11	SPECTBLS	1	75, 83, 113, 113
TBL12	SPECTBLS	1	100, 116
TBL13	SPECTBLS	1	74, 75, 83, 91, 94, 97, 100, 102, 105, 107, 107, 113, 113, 114, 115, 116, 116, 117, 117, 118, 118
TBL14A	SPECTBLS	1	91, 114
TBL14	SPECTBLS	1	102, 117
TBL15	SPECTBLS	1	
TBL16	SPECTBLS	1	150
TBL17	SPECTBLS	1	32
TBL18	SPECTBLS	1	
T1185	SPECTBLS	1	
TBL19	SPECTBLS	1	109
TBL20	SPECTBLS	1	72, 111
TBL21	SPECTBLS	1	146
TBL22	SPECTBLS	1	122, 157
TBL23	SPECTBLS	1	154, 158
TBL24	SPECTBLS	1	123, 160
TBL25	SPECTBLS	1	164
TBL26	SPECTBLS	1	
TBL27	SPECTBLS	1	102, 117
TBL28	SPECTBLS	1	
PADHD	SPECTBLS	1	
TBLF0H	SPECTBLS	1	75
TBLF0A	SPECTBLS	1	75, 75, 75, 94, 113, 113, 113, 115
TBLF0AH	SPECTBLS	1	
TBL03H	SPECTBLS	1	
TBL0FH	SPECTBLS	1	
TBL3FH	SPECTBLS	1	
TBL93H	SPECTBLS	1	44, 52, 119, 132, 152
TBLFBH	SPECTBLS	1	47, 47, 48, 48, 48, 48, 49, 49, 49, 49, 50, 50, 50, 50, 51, 51, 51, 51, 56, 56, 57, 57, 57, 58, 58, 58, 59, 59, 59, 59, 60, 60, 60, 61, 61, 61, 62, 66, 67, 69
TBLFFH	SPECTBLS	1	75, 113
TBLB8H	SPECTBLS	1	247
TBLECH	SPECTBLS	1	270
TBL03	SPECTBLS	1	

TBL29	SPECTBLS	1	97, 116
TBLE0H	SPECTBLS	1	105, 117
TBLF1H	SPECTBLS	1	102, 113, 117
TBLF8H	SPECTBLS	1	
TBLFCH	SPECTBLS	1	
TBL87H	SPECTBLS	1	105, 117
TBLC3H	SPECTBLS	1	
TBL1CH	SPECTBLS	1	136
TBL1DH	SPECTBLS	1	136, 148, 148
DFTTBL	SPECTBLS	1	26, 27, 27, 27, 27, 27, 27, 27, 27, 27, 27
DFTSECT	SPECTBLS	1	27, 27, 27, 27
THDSWEL	SPECTBLS	1	27
CENLEF	SPECTBLS	1	126, 130
DFFTHD	SPECTBLS	1	126, 130
DFFTBL	SPECTBLS	1	126, 130
STATHD	SPECTBLS	1	165
STBITHD	SPECTBLS	1	165, 165
STUS	SPECTBLS	1	165, 165, 165, 165, 165, 165, 165, 165
DMFMAT1	SPECTBLS	1	211, 211, 212, 212, 213, 214, 214, 215, 215, 215, 216, 216
DMFMAT2	SPECTBLS	1	
DMFMAT3	SPECTBLS	1	
DMFMAT4	SPECTBLS	1	
DMFMAT5	SPECTBLS	1	211, 211, 212, 212, 213, 214, 214, 215, 215, 215, 216, 216
DMFMAT6	SPECTBLS	1	211, 211, 212, 213, 213, 214, 214, 214, 214, 215, 215
DMFMAT7	SPECTBLS	1	211, 212, 212, 212, 213, 214, 214, 214, 215, 215, 215, 216, 216, 216, 216
COMPAT	SPECTBLS	1	
P10	SPECTBLS	1	27
TSNSHD	SPECTBLS	1	250
TSNSH1	SPECTBLS	1	229
TSNSH2	SPECTBLS	1	
TSNSBD	SPECTBLS	1	250, 250, 251, 251, 251, 251, 251, 251, 252, 252, 252, 252, 252, 252, 252, 253, 253, 253, 253, 253, 253, 253, 253, 254, 254, 254, 254, 254, 254, 254, 254, 254, 254, 255, 255, 256, 256, 256, 256, 256, 256, 257, 257, 257, 257, 257, 257, 257, 258, 258, 258, 258, 258, 258, 258, 258, 258, 259, 259, 259, 259, 259, 259, 260, 260, 260, 260, 260, 260, 260, 260, 261, 261, 261, 261, 261, 261, 261, 262, 262, 263, 264, 264, 264, 264, 265, 265, 265, 265, 265, 265, 266, 266, 266, 266, 266, 266, 266, 266, 267, 267, 267, 267, 267, 267, 267, 267, 268, 268, 268
TSNSB1	SPECTBLS	1	230
TSNSB2	SPECTBLS	1	
TSNSB3	SPECTBLS	1	65, 67, 250, 250, 256, 257, 259, 264, 265, 266, 266, 268
TSNSB4	SPECTBLS	1	
TDRPHD	SPECTBLS	1	274, 276, 276
TWRPHD	SPECTBLS	1	277, 277, 277

LSNP02H	LOGSNCMD	57	1.5.4, Log Sense Page 02h
LSNP03H	LOGSNCMD	58	1.5.5, Log Sense Page 03h
LSNP05H	LOGSNCMD	60	1.5.6, Log Sense Page 05h
LSNP06H	LOGSNCMD	61	1.5.7, Log Sense Page 06h
LSP35H	LOGSNCMD	69	1.5.11, Log Sense Page 35h 231
MSELECT	MDSELCMD	70	1.6, Mode Select (6) 110, 118, 228, 281
MODHDR	MDSELCMD	72	1.6.1.1, Header 111
MODBDR	MDSELCMD	73	1.6.1.2, Block Descriptor 24
MODPDR	MDSELCMD	74	1.6.1.3, Page Descriptor
PAGE0H	MDSELCMD	75	1.6.2, Page 0 - Vendor Unique Parameters 4, 4, 85, 90, 106, 144, 168, 179, 181, 212, 224, 229, 230, 241, 266
PAGE1H	MDSELCMD	83	1.6.3, Page 1 - Error Recovery Parameters 77, 121, 156
PAGE2H	MDSELCMD	91	1.6.4, Page 2 - Disconnect/Reconnect Parameters 3
PAGE3H	MDSELCMD	94	1.6.5, Page 3 - Format Device Parameters 24, 74
PAGE4H	MDSELCMD	97	1.6.6, Page 4h - Rigid Disk Drive Geometry Parameters 24, 225
PAGE7H	MDSELCMD	100	1.6.7, Page 7h - Error Recovery Parameters for Verify 75, 154, 158
PAGE8H	MDSELCMD	102	1.6.8, Page 8h - Caching Parameters 3, 122, 157, 159, 225, 231, 232, 232
PAGEAH	MDSELCMD	105	1.6.9, Page 0Ah - Control Mode Parameters 79, 80, 222
PAGECH	MDSELCMD	107	1.6.10, Page 0Ch - Notch Parameters
MSENSE	MDSNSCMD	109	1.7, Mode Sense (6) 70, 70, 71, 72
PREFET	PRFCHCMD	119	1.8, Pre-Fetch 165
READ10	READCMDS	122	1.10, Read (10) 231
READDEF	RDDEF CMD	126	1.13, Read Defect Data (10)
REDDEF2	RDDEF CMD	129	1.14, Read Defect Data (12)
REASGN	REASSCMD	133	1.16, Reassign Blocks 3
RELEASE	RELCMDS	137	1.18, Release (6) 166
REL10	RELCMDS	138	1.19, Release (10)
REQSNS	REQSNCMD	139	1.20, Request Sense 198
RESRV	RESCMDS	141	1.21, Reserve (6) 137, 138, 166
RESRV10	RESCMDS	142	1.22, Reserve (10)
RZERO	RZEROCMD	144	1.23, Rezero Unit
SEEK10	SEEKCMDS	145	1.25, Seek (10)
STRSTP	SUNITCMD	150	1.27, Start/Stop Unit 98

TURDY	TURDYCMD	153	1.29, Test Unit Ready 243
VERIFY	VERIFCMD	154	1.30, Verify 101
WRITEX	WRITCMD	157	1.32, Write (10) 231
WRITEV	WRTVYCMD	158	1.33, Write and Verify 101
WRTBUFR	WRBUFCMD	160	1.34, Write Buffer 3, 40, 286
STATBYT	CHAPTER2	165	2.0, SCSI Status Byte
SPTMSG	CHAPTER3	167	3.1, Supported Messages 4, 192
DISCMSG	CHAPTER3	169	3.1.4, Disconnect (04h) 168
CIOPTMSG	CHAPTER3	172	3.1.15, Continue I/O Process (12h) 172
TTDMSG	CHAPTER3	172	3.1.16, Target Transfer Disable (13h) 76, 79, 172, 220
QTAGMSG	CHAPTER3	173	3.1.17, Queue Tag Messages (20h, 21h, 22h) 222
C3IDMSG	CHAPTER3	174	3.1.19, Identify (80h or C0h) 169
SYNCI	CHAPTER3	176	3.1.21.2, Synchronous Negotiation Started by the Initiator 179
SYNCT	CHAPTER3	177	3.1.21.3, Synchronous Negotiation Started by the Target 179
WIDEI	CHAPTER3	180	3.1.22.2, Transfer Width Negotiation Started by the Initiator 181
WIDET	CHAPTER3	180	3.1.22.3, Transfer Width Negotiation Started by the Target 181
MSGFUNC	CHAPTER3	181	3.2, Supported Message Functions 169, 170, 170, 175
ATNCOND	CHAPTER3	182	3.3, Attention Condition 169, 170, 170, 177, 180, 185, 193
MSGTBL	CHAPTER3	186	3.5, Message State/Action Table 170, 170, 174, 179, 181
BUSERRS	CHAPTER3	192	3.6, SCSI Bus Related Error Handling Protocol 168, 169, 170, 170
BUSFREE	CHAPTER3	192	3.6.1, Unexpected Bus Free Phase Error Condition 172
MORTY	CHAPTER3	193	3.6.2, Message Out Phase Retry 179, 181, 185, 186
MIRTY	CHAPTER3	194	3.6.3, Message In Phase Retry 177, 178, 180, 181, 185
CORTY	CHAPTER3	194	3.6.4, Command Phase Retry 185
SIRTY	CHAPTER3	195	3.6.5, Status Phase Retry 185
DORTY	CHAPTER3	195	3.6.6, Data Out Phase Retry
DIRTY	CHAPTER3	195	3.6.7, Data In Phase Retry 185
PROTOCO	SCSIPROT	197	4.1, SCSI Protocol 223
STPRIOR	SCSIPROT	197	4.1.1, Priority of SCSI Status Byte Reporting 150, 200, 200, 201, 203, 219

BADLUN	SCSIPROT	198	4.1.2, Invalid LUN Processing 174, 197
TWOCMDS	SCSIPROT	199	4.1.3, Incorrect Initiator Connection 173, 192, 197, 200, 220, 221, 224
EXBUSY	SCSIPROT	200	4.1.4, Command Processing During Execution of Active I/O Process 166, 197, 223
UNITATN	SCSIPROT	202	4.1.5, Unit Attention Condition 24, 71, 71, 139, 162, 162, 171, 197, 226, 240
CPDSAF	SCSIPROT	205	4.1.6, Command Processing During Start-up and Format Oper- ations 24, 150, 197, 200
INTERR	SCSIPROT	206	4.1.7, Internal Error Condition 197
BRUPERR	SCSIPROT	207	4.1.8, Deferred Error Condition 26, 150, 197
DEGRAD	DEGRADE4	208	4.1.9, Degraded Mode 24, 133, 146, 197, 201, 201, 205, 286
DEGRENT	DEGRADE4	208	4.1.9.1, Reasons for Entering Degraded Mode
DEGLIM	DEGRADE4	210	4.1.9.2, Limitations of the Drive While in Degraded Mode
RESTOR	DEGRADE4	217	4.1.9.4, Exiting Degraded Mode 243
EXRSVD	SCSIPROT	219	4.1.10, Command Processing While Reserved 137, 138, 141, 142, 166, 197
PRICMDS	SCSIPROT	220	4.2, Priority Commands 78, 200, 223, 224, 233, 234
QSTUFF	COMQUEUE	221	4.3, Command Queuing 3, 3, 24, 30, 140
UNTAGQ	COMQUEUE	221	4.3.1, Untagged Queuing 223
TAGQ	COMQUEUE	222	4.3.2, Tagged Queuing 105, 166, 221
QRULES	COMQUEUE	223	4.3.4, Rules for Queuing commands
ERRONQ	COMQUEUE	223	4.3.5, Effects of errors on Command Queuing 222, 224, 225
QTERM	COMQUEUE	224	4.3.6, Termination of I/O processes 221
SAMETIM	BAK2BAK	224	4.4, Concurrent Command Processing 200
BAK2BAK	BAK2BAK	225	4.4.1, Back to Back Writes 3, 78, 102, 236
SYNCDES	MTRSYNC	225	4.5, Motor Synchronization 3, 24, 95, 95, 98, 151, 202, 203, 243, 278, 290
ERRLOGS	ERRLOGS	228	4.6, Error Logs 105
ATRCRES	ERRLOGS	228	4.7, Automatic Rewrite/Reallocate - Recommend Rewrite/Reassign 3, 3, 23, 66, 67, 77, 83, 84
PREFA	PFA	230	4.8, Predictive Failure Analysis 3, 78
SEGCAC	SEGCACH	231	4.9, Segmented Caching 3, 69, 102, 103, 104, 112, 122, 157, 159, 162
RLBA	SEGCACH	231	4.9.3, Read-Ahead 3, 119, 122
WCE	SEGCACH	235	4.9.4, Write Cache 102, 225
WCS	SEGCACH		

SEGSEL	SEGCACH	236	4.9.5, Synchronize Cache on SCSI Reset
		236	4.9.6, Segment Selection 233, 233, 234, 235, 235, 235
REPRI	SEGCACH	237	4.9.7, Segment Prioritization
SINIT	MISCHAP4	239	4.11, Single Initiator Selection
MULTINT	MISCHAP4	240	4.14, Multiple Initiator Systems 4
OPTPIN	MISCHAP4	241	4.15, Options Jumper Block 72
LEDPIN	MISCHAP4	241	4.16, LED Pin 3
RESET	MISCHAP4	242	4.17, Reset
RSTSRC	MISCHAP4	242	4.17.1, Reset Sources
RSTACTN	MISCHAP4	242	4.17.2, Reset Actions
BRINGUP	MISCHAP4	243	4.18, Bring-Up Sequence 133, 150, 217, 242
BATS	MISCHAP4	244	4.19, Basic Assurance Tests (BATS) 4
BTS1	MISCHAP4	244	4.19.1, BATS1 Tests 243
BTS2	MISCHAP4	244	4.19.2, BATS2 Tests 243
RSRVD	MISCHAP4	245	4.20, Reserved Area 243
SENSDAT	APPENDX1	247	Appendix A, SCSI Sense Data Format 4, 71, 139, 150, 295
APNDX2	APPENDX2	273	Appendix B, Recovery Procedures
DRPDESC	APPENDX2	273	B.1, Data Recovery Procedure for Data Field Errors 75, 90, 90, 121, 156
RRECDES	APPENDX2	274	B.1.1, Read Commands
VRPDESC	APPENDX2	275	B.1.2, Verify Commands 101, 101, 154, 158
WRPDESC	APPENDX2	277	B.1.3, Write Commands (No Sector Found)
SRPDESC	APPENDX2	277	B.2.1, Position Error (Servo Error Recovery)
PRPDESC	APPENDX2	277	B.2.2, Drive Fault
ERRPTY	APPENDX2	278	B.3, Priority of Error Reporting 87, 87, 88, 88, 88, 89, 89, 89, 153
SCTRREL	APPENDX3	279	Appendix C, Recommended Initiator Error Recovery Procedures 217
SERVICE	APPENDX3	279	C.1, Drive service strategy 284, 284, 285, 285, 285, 286, 286, 286, 287, 287, 287, 287, 287, 288, 288, 290, 291, 291, 291, 292, 292, 292, 292, 293, 293, 293, 293, 293, 294
ERRLOG	APPENDX3	280	C.2, Recommendations for System Error Log
DRP11	APPENDX3	280	C.3, Data Recovery Procedure
DRP1	APPENDX3	281	C.3.1, Rewrite an LBA 252, 253, 254
DRP3	APPENDX3	282	C.3.2, Reassign a physical sector 251, 252, 252, 253, 253, 254, 257, 258, 258, 258
DRP2	APPENDX3	283	C.3.3, Data error logging 251, 251, 252, 252, 252, 252, 253, 253, 253, 253, 253, 254, 254, 254, 257, 258, 258
ASSIGN	APPENDX3	284	C.3.4, Reassign Blocks Recovery

			257, 257, 258, 258, 260, 283, 287
NONDATA	APPENDX3	284	C.4, Non-Data Error Recovery Procedure
NOERR	APPENDX3	284	C.4.1, Drive busy 256, 256
ERP1	APPENDX3	285	C.4.2, Unrecovered drive error 259, 259, 259, 259, 260, 260, 260, 263, 264
ERP2	APPENDX3	285	C.4.3, Recovered drive error 250, 251, 251, 251, 252, 252, 255, 285, 285
ERP3	APPENDX3	285	C.4.4, Drive not ready 256
ERP7	APPENDX3	285	C.4.5, No defect spare 261
CRPTFMT	APPENDX3	286	C.4.6, Degraded Mode 256, 256, 257, 257, 257, 259, 261, 261, 261
DRP	APPENDX3	287	C.4.7, Reserved Area Hard Error 258, 258, 260, 260, 260, 260, 260, 261
ERP9	APPENDX3	287	C.4.8, Interface Protocol 264, 264, 265, 265, 265, 265
ERP10	APPENDX3	288	C.4.9, Aborted Command 265, 267, 267, 267, 267, 267, 267, 267, 267, 268, 268
ERP5	APPENDX3	289	C.4.10, Unit Attention
UANRTR	APPENDX3	289	C.4.10.1, Not Ready to Ready Transition 265
UAPOR	APPENDX3	289	C.4.10.2, Reset 265
UAMPC	APPENDX3	289	C.4.10.3, Mode Parameters Changed 266
UAMCCH	APPENDX3	289	C.4.10.4, Microcode has Changed 266
UACCAI	APPENDX3	289	C.4.10.5, Commands Cleared by Another Initiator 266
UASS	APPENDX3	289	C.4.10.6, Spindles Synchronized 266
UASNS	APPENDX3	289	C.4.10.7, Spindles Not Synchronized 255, 264, 266
UALPC	APPENDX3	290	C.4.10.8, Log Select Parameters Changed 266
ERP13	APPENDX3	290	C.4.11, Components Mismatch 262, 262
ERP14	APPENDX3	291	C.4.12, Self Initiated Reset 257, 261
DEFLIST	APPENDX3	292	C.4.13, Defect List Recovery 254, 254, 254
MISCOMP	APPENDX3	292	C.4.14, Miscompare recovery 268
CHKSUM	APPENDX3	293	C.4.15, Microcode error 257, 261
PREDICT	APPENDX3	294	C.4.16, Predictive failure analysis 256
UECLIST	APPENDX4	295	Appendix D, UEC List

MDSNP2	MDSNSCMD	114	89	
MDSNP3	MDSNSCMD	115	90	
MDSNP4	MDSNSCMD	116	91	
MDSNP7	MDSNSCMD	116	92	
MDSNP8	MDSNSCMD	117	93	
MDSNPA	MDSNSCMD	117	94	
MDSNPC	MDSNSCMD	118	95	
STATUS	CHAPTER2	165	141	
				165
MSGLGNT	CHAPTER3	187	155	
MSGTBL1	CHAPTER3	189	157	
MSGTBL2	CHAPTER3	190	158	
MSGTBL3	CHAPTER3	191	159	
SNSCOMB	APPENDX1	250	162	
				250, 250
LRETRYC	APPENDX1	269	163	
				269
LPROGIN	APPENDX1	269	164	
				269
LFLDPTR	APPENDX1	270	165	
				270
WRTCODE	APPENDX3	281	172	
				281
RSGCODE	APPENDX3	282	173	
				282
LOGCODE	APPENDX3	283	174	
				283

Processing Options

Runtime values:

Document fileid	DOCUMENT STARSCSI
Document type	USERDOC
Document style	ISO9000
Profile	EDFPRF40
Service Level	0028
SCRIPT/VS Release	4.0.0
Date	95.02.20
Time	13:27:29
Device	3820A
Number of Passes	2
Index	YES
SYSVAR G	INLINE
SYSVAR H	Y
SYSVAR R	STARFIRE
SYSVAR W	STARFIRE
SYSVAR X	XONLY
SYSVAR I	OEM

Formatting values used:

Annotation	NO
Cross reference listing	YES
Cross reference head prefix only	NO
Dialog	LABEL
Duplex	YES
DVCF conditions file	(none)
DVCF value 1	OEM
DVCF value 2	(none)
DVCF value 3	(none)
DVCF value 4	(none)
DVCF value 5	(none)
DVCF value 6	(none)

DVCF value 7	(none)
DVCF value 8	(none)
DVCF value 9	(none)
Explode	NO
Figure list on new page	YES
Figure/table number separation	YES
Folio-by-chapter	NO
Head 0 body text	(none)
Head 1 body text	(none)
Head 1 appendix text	Appendix
Hyphenation	YES
Justification	NO
Language	ENGL
Keyboard	395
Layout	OFF
Leader dots	YES
Master index	(none)
Partial TOC (maximum level)	4
Partial TOC (new page after)	RHPAGE
Print example id's	NO
Print cross reference page numbers	YES
Process value	(none)
Punctuation move characters
Read cross-reference file	STARFIRE
Running heading/footer rule	NONE
Show index entries	NO
Table of Contents (maximum level)	3
Table list on new page	YES
Title page (draft) alignment	RIGHT
Write cross-reference file	STARFIRE

Named Files

<u>Fileid</u>	<u>Page</u>	<u>Data Set Name</u>
CORNERS	1	CORNERS SCRIPT
DEC2HEX	1	DEC2HEX SCRIPT
COMMAS	1	COMMAS SCRIPT
SYMBOLS	1	SYMBOLS STARFIRE
SPECTBLS	1	SPECTBLS STARSCSI
CHAPTER1	21	CHAPTER1 STARSCSI
FORMAT	23	FORMAT STARSCSI
INQRYCMD	29	INQRYCMD STARSCSI
LOGSECMD	43	LOGSECMD STARSCSI
LOGSNCMD	52	LOGSNCMD STARSCSI
MSELCMD	70	MSELCMD STARSCSI
MDSNSCMD	109	MDSNSCMD STARSCSI
PRFHCMD	118	PRFHCMD STARSCSI
READCMDS	120	READCMDS STARSCSI
RDBUFCMD	122	RDBUFCMD STARSCSI
RDCAPCMD	124	RDCAPCMD STARSCSI
RDDEFCMD	125	RDDEFCMD STARSCSI
RDLNGCMD	131	RDLNGCMD STARSCSI
REASSCMD	132	REASSCMD STARSCSI
RDIAGCMD	134	RDIAGCMD STARSCSI
RELCMDS	136	RELCMDS STARSCSI
REQSNCMD	138	REQSNCMD STARSCSI
RESCMDS	140	RESCMDS STARSCSI
RZEROCMD	143	RZEROCMD STARSCSI
SEEKCMDS	144	SEEKCMDS STARSCSI
SDIAGCMD	145	SDIAGCMD STARSCSI
SUNITCMD	149	SUNITCMD STARSCSI
SYNCHCMD	151	SYNCHCMD STARSCSI
TURDYCMD	152	TURDYCMD STARSCSI
VERIFCMD	153	VERIFCMD STARSCSI
WRITCMDS	155	WRITCMDS STARSCSI
WRTVYCMD	157	WRTVYCMD STARSCSI
WRBUFCMD	159	WRBUFCMD STARSCSI
WRLNGCMD	162	WRLNGCMD STARSCSI
WRSMECMD	163	WRSMECMD STARSCSI
CHAPTER2	164	CHAPTER2 STARSCSI
CHAPTER3	166	CHAPTER3 STARSCSI
CHAPTER4	196	CHAPTER4 STARSCSI
SCSIPROT	196	SCSIPROT STARSCSI
COMQUEUE	196	COMQUEUE STARSCSI
BAK2BAK	196	BAK2BAK STARSCSI
MTRSYNC	196	MTRSYNC STARSCSI
ERRLOGS	196	ERRLOGS STARSCSI
PFA	196	PFA STARSCSI
SEGCACH	196	SEGCACH STARSCSI
LGBLKSZE	196	LGBLKSZE STARSCSI
LRC	196	LRC STARSCSI
MISCHAP4	196	MISCHAP4 STARSCSI

DEGRADE4	196	DEGRADE4 STARSCSI
ARRECREL	228	ARRECREL STARSCSI
APPENDX1	247	APPENDX1 STARSCSI
SNSCOMBO	250	SNSCOMBO STARSCSI
APPENDX2	271	APPENDX2 STARSCSI
DRPTABLE	274	DRPTABLE STARSCSI
VWPTABLE	276	VWPTABLE STARSCSI
VRPTABLE	276	VRPTABLE STARSCSI
WRPTABLE	277	WRPTABLE STARSCSI
SRPTABLE	277	SRPTABLE STARSCSI
PRPTABLE	277	PRPTABLE STARSCSI
APPENDX3	278	APPENDX3 STARSCSI
APPENDX4	294	APPENDX4 STARSCSI
UECLIST	295	UECLIST STARSCSI
GLOSSARY	303	GLOSSARY STARSCSI
SYMBOLS	303	SYMBOLS STARFIRE

Imbed Trace

Page 0	CORNERS
Page 0	DEC2HEX
Page 0	COMMAS
Page 0	SETUP STARSCSI
Page 0	SYMBOLS
Page 0	SPECTBLS
Page 3	FEATURES STARSCSI
Page 4	SCSIATM2 STARSCSI
Page 20	CHAPTER1
Page 23	FORMAT
Page 28	INQRYCMD
Page 43	LOGSECMD
Page 52	LOGSNCMD
Page 70	MDSELCMD
Page 109	MDSNSCMD
Page 118	PRFHCMD
Page 120	READCMDS
Page 122	RDBUFCMD
Page 124	RDCAPCMD
Page 125	RDDEF CMD
Page 131	RDLNGCMD
Page 132	REASSCMD
Page 134	RDIAGCMD
Page 136	RELCMDS
Page 138	REQSNCMD
Page 139	RESCMDS
Page 142	RZEROCMD
Page 144	SEEKCMDS
Page 145	SDIAGCMD
Page 149	SUNITCMD
Page 151	SYNCHCMD
Page 152	TURDYCMD
Page 153	VERIFCMD
Page 154	WRITCMDS
Page 157	WRTVYCMD
Page 159	WRBUFCMD
Page 162	WRLNGCMD
Page 163	WRSMECMD
Page 164	CHAPTER2
Page 166	CHAPTER3
Page 196	CHAPTER4
Page 196	SCSIProt
Page 208	DEGRADE4
Page 220	COMQUEUE
Page 224	BAK2BAK
Page 225	MTRSYNC
Page 227	ERRLOGS
Page 228	ARRECREL
Page 230	PFA
Page 230	SEGCACH
Page 238	MISCHAP4
Page 246	APPENDX1
Page 250	SNSCOMBO
Page 271	APPENDX2
Page 274	DRPTABLE
Page 275	VWPTABLE
Page 276	VRPTABLE
Page 277	WRPTABLE
Page 277	SRPTABLE
Page 277	PRPTABLE
Page 278	APPENDX3
Page 294	APPENDX4

Page 295
Page 302
Page 302

UECLIST
GLOSSARY
SYMBOLS