



Product summary

Travelstar 18GT

ATA/IDE



Models: DARA-218000
DARA-215000

Introducing

IBM's latest 2.5 inch hard disk drives provide capacities of 18GB and 15GB with a height of 12.7 mm. The latest GMR head technology, IBM's patented No-ID sector formatting, the S.M.A.R.T. function, advanced power saving modes, and IBM's "Load/Unload heads" technology make the Travelstar 18GT particularly suited to mobile computing and multimedia applications.

Applications

- High performance portable computers
- Non-IT - process control/fax
- Removable/secure storage units

Features

- 18 GB or 15 GB at 512 bytes/sector
- Enhanced IDE interface with Ultra-DMA data transfer - mode 4 (66.6MB/sec)
- PIO data transfer - mode 4 (16.6MB/sec)
- Shock 700G (1ms) non-operational
- Shock 175G (2ms) operational
- 161.6 - 85.5 Mbits/sec media data transfer rate
- Rotational speed 4200 RPM
- Average seek time 12ms (read)
- Average latency 7.1ms
- Giant Magnetoresistive heads
- No-ID sector formatting
- PRML data channel
- 512 KB segmented buffer with write cache
- Enhanced ECC On-The-Fly
- Adaptive power save control (0.65 Watt at idle state)
- Load/Unload heads
- S.M.A.R.T. function
- Drive Fitness Test (DFT) technology

Benefits

- High capacity in slim 2.5 inch form factor
- Popular interface with excellent performance
- Robust design for portable computing applications
- Excellent data rate across disk surface
- Fast access to data
- High areal density, low component count
- More data stored per track, increased sustained data transfer rate
- Fast access to data and improved throughput
- High reliability
- Low power for battery powered applications
- Increased durability during power save modes and non-operation
- Protection of user data

Electrical connector locations

Drive Address

Jumper positions to determine the drive address are available at the interface connector. The diagram below reflects jumper pin location.

When using Cable Selection, the drive address depends on the condition of pin 28 of the AT interface cable. If pin 28 is ground or low, the drive is a Master. If pin 28 is open or high level, the drive is a Slave.

Cabling

The maximum cable length from the host system to the drive plus the length of the circuit pattern in the host system shall not exceed 18 inches.

AT Signal Connector

The AT signal connector is designed to mate with Dupont part number 69764-044 or equivalent.

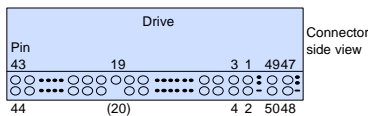

DC power requirements

Nominal supply	+5 Volt
Power supply ripple ¹	100 mV p-p max
Tolerance ²	±5%
Supply wattage (+5.00 V case)	Population mean (Nominal condition)
Performance idle average (typical) ³	1.85 W
Active idle average (typical)	0.95 W
Low power idle average (typical)	0.65 W
Read average (typical) ⁴	2.1 W
Write average (typical)	2.2 W
Seek average (typical) ⁵	2.3 W
Standby (typical)	0.25 W
Sleep (typical)	0.1 W
Startup (maximum peak) (typical)	4.7 W
Startup (average from power on to ready) (typical)	3.3 W

Notes

1. The maximum fixed disk ripple is measured at 5V input of the drive.
2. The disk drive shall not incur damage for an over voltage condition of +25% (maximum duration of 20 ms) on the 5 volt nominal supply.
3. The idle current is specified at an inner track.
4. The read/write current is specified based on three operations of 63 sector read/write per 100msec.
5. The seek average current is specified based on three operations per 100msec.

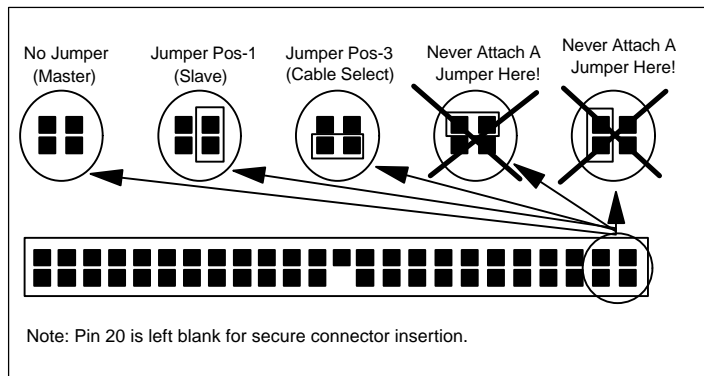

Data organization

	DARA-218000	DARA-215000
Number of logical heads	16	16
Sectors/track	63	63
Cylinder number	16,383	16,383
Total customer usable data sectors	35,433,216	29,498,112
Total customer usable data bytes	18,141,806,592	15,103,033,344

Command descriptions

The following commands are supported by the drive:

Command	Code (Hex)	Protocol
Check power mode	E5	3
Check power mode*	98	3
Execute device diagnostic	90	3
Flush cache	E7	3
Format track	50	2
Format unit	F7	3+
Identify device	EC	1
Identify device DMA	EE	4
Idle	E3	3
Idle*	97	3
Idle immediate	E1	3
Idle immediate*	95	3
Initialize device parameters	91	3
Read buffer	E4	1
Read DMA (retry)	C8	4
Read DMA (no retry)	C9	4
Read long (retry)	22	1
Read long (no retry)	23	1
Read multiple	C4	1
Read native max address	F8	3
Read sectors (retry)	20	1
Read sectors (no retry)	21	1
Read verify sectors (retry)	40	3
Read verify sectors (no retry)	41	3
Recalibrate	1x	3
Security disable password	F6	2
Security erase prepare	F3	3
Security erase unit	F4	2
Security freeze lock	F5	3
Security set password	F1	2
Security unlock	F2	2
Seek	7x	3
Set features	EF	3
Set max address	F9	3
Set multiple mode	C6	3
Sleep	E6	3
Sleep*	99	3
SMART disable operations	B0	3
SMART enable/disable attribute autosave	B0	3

SMART enable operations	B0	3
SMART execute off-line immediate	B0	3
SMART read attribute values	B0	1
SMART read attribute thresholds	B0	1
SMART return status	B0	3
SMART save attribute values	B0	3
Standby	E2	3
Standby*	96	3
Standby immediate	E0	3
Standby immediate*	94	3
Write buffer	E8	2
Write DMA (retry)	CA	4
Write DMA (no retry)	CB	4
Write long (retry)	32	2
Write long (no retry)	33	2
Write multiple	C5	2
Write sectors (retry)	30	2
Write sectors (no retry)	31	2
Write verify	3C	2

Protocol

- 1 PIO data IN command
 - 2 PIO data OUT command
 - 3 Non data command
 - 4 DMA command
- + Vendor specific command

* Alternate command codes for previously defined commands

Signal definition

The pin assignments of interface signals are listed as follows:

Pin	Signal	I/O
1	-RESET	I
2	GND	
3	DD07	I/O
4	DD08	I/O
5	DD06	I/O
6	DD09	I/O
7	DD05	I/O
8	DD10	I/O
9	DD04	I/O
10	DD11	I/O
11	DD03	I/O
12	DD12	I/O
13	DD02	I/O
14	DD13	I/O
15	DD01	I/O

16	DD14	I/O
17	DD00	I/O
18	DD15	I/O
19	GND	
-20	KEY	
21	DMARQ	O
22	GND	
23	-DIOW(*)	I
24	GND	
25	-DIOR(*)	I
26	GND	
27	IORDY(*)	O
28	CSEL	I
29	-DMACK	I
30	GND	
31	INTRQ	O
32	-IOCS16	O
33	DA01	I
34	-PDIAG	I/O
35	DA00	I
36	DA02	I
37	-CS0	I
38	-CS1	I
39	-DASP	I/O
40	GND	
41	+5V logic	power
42	+5V motor	power
43	GND	
44	(reserve)	

Notes

“O” designates an output from the drive.

“I” designates an input to the drive.

I/O” designates an input/output common.

“OD” designates Open-Drain output.

(*) designates signal lines that are redefined during the Ultra DMA protocol to provide special functions. If the Ultra DMA transfer mode was previously chosen via Set Features, these lines change from the conventional to special definitions at the moment the Host decides to allow a DMA burst. The drive becomes aware of this change upon assertion of the -DMACK line. These lines revert back to their original definitions upon the deassertion of -DMACK at the termination of the DMA burst.

“Power” designates a power supply to the drive.

“Reserve” designates reserved pins which must be left unconnected.

	Special definition (for Ultra DMA)	Conventional definition
Write operation	-DDMARDY -HSTROBE -STOP	IORDY -DIOR -DIOW
Read operation	-HDMARDY -DSTROBE -STOP	-DIOR IORDY -DIOW

5V power

There are two input pins for +5V power supply, "+5V Logic" and "+5V Motor". "+5V Logic" is connected to the internal logic circuits and "+5V Motor" is connected to the spindle motor and motor driver.

"+5V Logic" can be turned on and off by an external switch circuit to reduce power consumption. In this mode, a voltage drop out due to the motor spin up current can be reduced by connecting the "+5V Motor" line directly into the system power source.

If the above power management option is used, all signal lines that will be electrically active in the host system while the drive is disconnected from the power line shall be isolated by Three-State line drivers. Internal leakage through the ESD protection circuit may bring the Least Positive Up Level (LPUL) of the logic signal below specifications.

Use both lines in parallel for regular drive application.

Load/Unload heads

The Load/Unload mechanism allows 300,000 cycles of controlled loads and unloads. The heads are unloaded by invoking one of the following commands:

HARD RESET
SOFT RESET
STANDBY
STANDBY IMMEDIATE
SLEEP

It is also invoked as one of the idle modes. After a short period of inactivity the Adaptive Battery Life Extender power management will unload the heads to conserve energy. When the heads are unloaded, they rest in a small detent. To prevent the heads from being thrown off the ramp during angular acceleration, a bi-directional, normally open, mechanical latch engages with the actuator to keep it from turning in the head loading direction. This action causes a "rattle" sound to be heard which can be mistaken for loose parts.

Adaptive Battery Life Extender

The Adaptive Battery Life Extender (ABLE-2) provides power saving without performance degradation. ABLE-2 technology automatically determines the correct time to start removing power from the drive electronics.

Most software and operating systems make use of a disk drive in bursts. The Travelstar drives monitor the commands which are sent from the host to detect patterns which indicate that a command sequence is finished by putting the drive into low overall power consumption and longer battery life with no loss in performance. If the host system changes the number or frequency of commands which it sends then the disk drive will adapt automatically to this new pattern.

This feature has three idle modes; Performance idle mode, Active idle mode, and Low Power idle mode.

Operating modes

To provide the greatest flexibility of operation with optimum performance and power consumption, the drive has a number of operating modes. These are defined below.

Spin-Up

Start up time period from spindle stop or power down

Seek

Seek operation mode

Write

Write operation mode

Read

Read operation mode

Performance idle

The device is capable of responding immediately to media access requests. All electronic components remain powered and the full frequency servo remains operational.

Active idle

The device is capable of responding immediately to media access requests. Some circuitry including servo system and R/W electronics are in power saving mode. The head is parked near the mid-diameter of the disk without servoing. A device in active idle mode may take longer to complete the execution of a command because it has to activate that circuitry.

Low Power idle

Head is unloaded on the ramp position. Spindle motor is rotating at full speed.

Standby

The device interface is capable of accepting commands. Spindle motor is stopped. All circuitry except host host interface are in power saving mode. The execution of commands is delayed until spindle becomes ready.

Sleep

The device requires a soft reset or a hard reset to be activated. All electronics including spindle motor and host interface are shut off.

Electromagnetic compatibility

The drive meets the following worldwide EMC requirements when installed in a suitable enclosure and exercised with a random accessing routine at the maximum data rate:

United States Federal Communications Commission (FCC) Rules and Regulations (Class B), Part 15

This drive is certified for compliance to EC directive 89/666/EEC.

C-Tick Mark complies with Australian EMC standard, AS/NZS 3548 : 1995 Class B.

Operating environment

The drive operates within its performance limits when the following environment is maintained. Product life calculations are based on the nominal environment for a typical application.

Relative humidity

(non-condensing)

Operating	8 to 90%
Non-operating	5% to 95%

Wet bulb temperature

(non-condensing)

Operating	29.4 °C
Non-operating	40 °C

Elevation

Operating	-300 to 3,000 m (10Kft)
Non-operating	-300 to 12,000 m (40Kft)

Temperature

Operating	5 to 55 °C
Non-operating	-40 to 65 °C
Gradient	20 °C/hour

Air cooling requirement

The host system must provide sufficient air flow across the drive to maintain the temperature at less than 60 °C at the center of the top cover of the drive and below 63 °C at the center of the card of the drive.

Operating shock

The drive will withstand, with no hard error, a 175G half-sine shock pulse of 2ms duration or 15G half-sine shock pulse for 11ms.

Non-operating shock

The drive will withstand with no permanent damage or degradation in performance a 120G half-sine shock pulse of 11ms duration or 700G half-sine shock pulse for 1ms.

Operating and non-operating vibration

Due to the complexity of this subject we recommend that users contact the distributor to discuss how to perform the necessary measurements if they believe this to be an area which requires evaluation.

Acoustics

The upper limit criteria of the A-weighted sound power levels are given in Bel relative to one pico watt and are shown in the following table. The measurement method is in accordance with ISO7779.

A-weighted sound power level

Mode	[Bel]	
	typical	max
Idle	3.2	3.5
Operating	3.5	3.8

S.M.A.R.T. function

The intent of Self-Monitoring, Analysis, and Reporting Technology (S.M.A.R.T.) is to protect user data and prevent unscheduled system downtime that may be caused by predictable degradation or fault of the device. By monitoring and storing critical performance and calibration parameters, S.M.A.R.T. devices employ sophisticated data analysis algorithms to predict the likelihood of near-term degradation or fault condition. By alerting the host system of a negative reliability status condition, the host system can warn the user of the impending risk of a data loss and advise the user of appropriate action.

Since S.M.A.R.T. utilizes the internal device microprocessor and other device resources, there may be some small overhead associated with its operation. However, special care has been taken in the design of the S.M.A.R.T. algorithms to minimize the impact to host system performance. Actual impact of S.M.A.R.T. overhead is dependent on the specific device design and the usage patterns of the host system.

To further ensure minimal impact to the user, S.M.A.R.T. capable devices are shipped from the device manufacturer's factory with the S.M.A.R.T. feature disabled. S.M.A.R.T. capable devices can be enabled by the system OEMs at the time of system integration or in the field by after market products.

For further details refer to the drive specification.

Mechanical data

Weight: 135 grams

Dimensions	S.I. Metric
Height	12.7mm + 0.0/ -0.5
Width	69.85mm ± 0.25
Length	100.2mm ± .25

Mounting orientation

The recommended mounting screw torque is 3.0 ± 0.5 kgf.cm.

The recommended mounting screw thread length is 3.0 ± 0.3 mm for bottom and 3.5 ± 0.5 mm for horizontal mounting.

The drive mounting hole locations and sizes are show below.

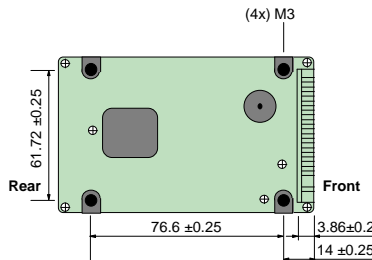
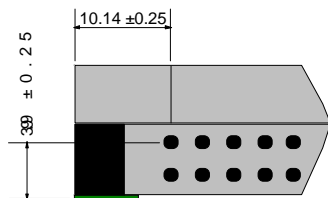
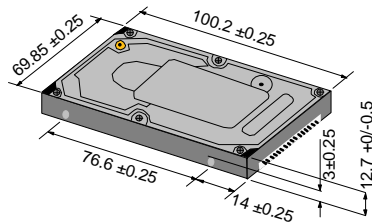

Drive usage conditions

The drive is designed to be used under the following conditions:

- Levels of shock, vibration, temperature, humidity, altitude, and magnetic fields are within the specifications.
- Measures are taken against ESD.
- The breathing hole on top of the drive is not covered.
- Pressure is not applied to the top cover of the drive.
- The drive is operated within the specification of less than 140 power-on hours per month. Seeking, Writing, and Reading operation of the drive should be no more than 20% of power-on hours.
- The power requirements of the drive are satisfied.
- The drive frame is grounded electrically to the system by four screws.
- The drive is mounted with the recommended screw depth and torque.
- Physical and electrical requirements of the interface are satisfied per ATA-4.
- The proper power-off sequence is used (see the drive specification for further details).



© International Business Machines Corporation 2000

www.ibm.com/harddrive

IBM Technology Group Support Center
Telephone: 888.IBM.5214 or 507.286.5825
E-mail: drive@us.ibm.com

Singapore Technology Group Support Center
Telephone: (65)6418.9595 or 1800.418.9595
E-mail: drive@sg.ibm.com

UK Technology Group Support Center
Telephone: 44.1475.898.125
E-mail: drive@uk.ibm.com

Germany Technology Group Support Center
Telephone: 49.7032.153050
E-mail: drive@de.ibm.com

IBM Storage Systems Division
5600 Cottle Road
San Jose, CA 95193
www.ibm.com/storage

Printed in the United States of America
03-2000
All Rights Reserved

IBM, No-ID, and Predictive Failure Analysis are the registered trademarks and Travelstar is the trademark of International Business Machines Corporation.

AMP is a trademark of AMP Incorporated.
DATA MATE is a trademark of AMP Incorporated.
Molex is a trademark of Molex Incorporated.

Other company, product, and service names may be trademarks or service marks of others.

Produced by the IBM Technology Group Support Center.

OEM Hard Disk Drive Specification for DARA-2xxxxx, 2.5 Inch Hard Disk Drive with ATA interface, Revision (2.0)

This product summary is not a substitute for the full production specification, which should be used when detailed information is required.

Product Description data represents IBM's design objectives and is provided for comparative purposes; actual results may vary based on a variety of factors. This product data does not constitute a warranty. Questions regarding IBM's warranty terms or methodology used to derive this data should be referred to the IBM Hard Disk Drive Technical Support Center. Data subject to change without notice.

Date: 28 March 2000