



---

# **OEM HARD DISK DRIVE SPECIFICATIONS**

**for**

**DMCA-21080/21440 (1080/1440 MB)**

**2.5-Inch Hard Disk Drive with ATA Interface**

**Revision (2.0)**

---





---

# **OEM HARD DISK DRIVE SPECIFICATIONS**

**for**

**DMCA-21080/21440 (1080/1440 MB)**

**2.5-Inch Hard Disk Drive with ATA Interface**

**Revision (2.0)**

---

**1st Edition (1.0) S46H-6807-00 (Jan. 31, 1996)**  
**2nd Edition (1.1) S46H-6807-01 (Apr. 01, 1996)**  
**3rd Edition (1.2) S46H-6807-02 (May. 08, 1996)**  
**4th Edition (1.3) S46H-6807-03 (May. 20, 1996)**  
**5th Edition (2.0) S46H-6807-04 (Sep. 10, 1996)**

**The following paragraph does not apply to the United Kingdom or any country where such provisions are inconsistent with local law:** INTERNATIONAL BUSINESS MACHINES CORPORATION PROVIDES THIS PUBLICATION “AS IS” WITHOUT WARRANTY OF ANY KIND, EITHER EXPRESS OR IMPLIED, INCLUDING, BUT NOT LIMITED TO, THE IMPLIED WARRANTIES OF MERCHANTABILITY OR FITNESS FOR A PARTICULAR PURPOSE. Some states do not allow disclaimer or express or implied warranties in certain transactions, therefore, this statement may not apply to You.

This publication could include technical inaccuracies or typographical errors. Changes are periodically made to the information herein; these changes will be incorporated in new editions of the publication. IBM may make improvements and/or changes in the product(s) and/or the program(s) described in this publication at any time.

It is possible that this publication may contain reference to, or information about, IBM products (machines and programs), programming, or services that are not announced in your country. Such references or information must not be construed to mean that IBM intends to announce such IBM products, programming, or services in your country.

Technical information about this product is available from your local IBM representative or at **<http://www.ibm.com/harddrive>**

IBM may have patents or pending patent applications covering subject matter in this document. The furnishing of this document does not give you any license to these patents. You can send license inquiries, in writing, to the IBM Director of Commercial Relations, IBM Corporation, Armonk, NY 10577.

**© Copyright International Business Machines Corporation 1996. All rights reserved.**

Note to U.S. Government Users —Documentation related to restricted rights —Use, duplication or disclosure is subject to restrictions set forth in GSA ADP Schedule Contract with IBM Corp.

---

# Contents

<b>1.0 General</b>	1
1.1 Glossary	1
1.2 General Caution	1
1.2.1 Caution of usage	2
<b>2.0 General Features</b>	5
<hr/>	
<b>Part 1. Functional Specification</b>	7
<b>3.0 Drive Characteristics</b>	9
3.1 Logical Drive Format	9
3.2 Data Sheet	9
3.3 Performance Characteristics	10
3.3.1 Command Processing	10
3.3.2 Average Seek Time (Including Settling)	10
3.3.3 Single Track Seek Time	11
3.3.4 Full Stroke Seek	12
3.3.5 Average Latency	12
3.3.6 Drive Ready Time	12
3.3.7 Operating Modes.	13
<b>4.0 Data Integrity</b>	15
4.1 Data Loss by Power Off	15
4.2 Write Cache	15
4.3 Equipment Status	15
4.4 WRITE Safety	16
4.5 Data buffer test	16
4.6 Error Recovery	16
4.7 Automatic Reallocation	16
4.7.1 Non Recovered Write Errors	16
4.7.2 Non Recovered Read Errors	16
4.7.3 Recovered Read Errors	16
<b>5.0 Specification</b>	17
5.1 Environment	17
5.1.1 Temperature and Humidity	17
5.1.2 Magnetic Fields	18
5.2 DC Power Requirements	19
5.2.1 Start Up Current	20
5.3 Reliability	21
5.3.1 Contact Start Stop (CSS)	21
5.3.2 Preventive Maintenance	21
5.3.3 Data Reliability	21
5.3.4 Failure Prediction ( S.M.A.R.T.)	21
5.3.5 Cable Noise Interference	21
5.4 Mechanical Specifications	22
5.4.1 Mechanical Dimensions and Weight	22
5.4.2 Hole Locations	22
5.4.3 Mounting Orientation	24
5.4.4 Shipping Zone and Lock	24

5.5	Vibration and Shock	25
5.5.1	Operating Vibration	25
5.5.2	Non-Operating Vibrations	25
5.5.3	Operating Shock	26
5.5.4	Non-Operating Shock	26
5.6	Acoustics	27
5.6.1	Sound Power Levels	27
5.6.2	Sound Power Acceptance Criteria	27
5.7	Identification	29
5.7.1	Labels	29
5.8	Electromagnetic Compatibility	29
5.8.1	CE Mark	29
5.9	Safety	30
5.9.1	Underwriters Lab(UL) Approval	30
5.9.2	Canadian Standards Authority(CSA) Approval	30
5.9.3	IEC Compliance	30
5.9.4	German Safety Mark	30
5.9.5	Flammability	30
5.9.6	Secondary Circuit Protection	30
5.10	Packaging	30
<b>6.0</b>	<b>Electrical Interface Specifications</b>	<b>31</b>
6.1	Cabling	31
6.2	Interface Connector	31
6.3	Signal Definition	32
6.4	Signal Description	33
6.5	Interface Logic Signal Levels	35
6.6	Signal Timings	35
6.6.1	Reset Timings	35
6.6.2	PIO Timings	36
6.6.3	DMA Timings (Single Word)	37
6.6.4	DMA Timings (Multiword)	38
6.7	Drive Address Setting	39
6.7.1	Default Setting	39
6.8	Addressing of drive Registers	40
<hr/>		
<b>Part 2.</b>	<b>ATA Interface Specification</b>	<b>41</b>
<b>7.0</b>	<b>General</b>	<b>43</b>
7.1	Introduction	43
7.2	Terminology	43
<b>8.0</b>	<b>Deviations From Standard</b>	<b>45</b>
<b>9.0</b>	<b>Registers</b>	<b>47</b>
9.1	Alternate Status Register	47
9.2	Command Register	48
9.3	Cylinder High Register	48
9.4	Cylinder Low Register	48
9.5	Data Register	48
9.6	Device Control Register	49
9.7	Drive Address Register	49
9.8	Device/Head Register	49
9.9	Error Register	50

9.10	Features Register	51
9.11	Sector Count Register	51
9.12	Sector Number Register	51
9.13	Status Register	51
<b>10.0</b>	<b>General Operation Descriptions</b>	<b>53</b>
10.1	Reset Response	53
10.1.1	Register Initialization	55
10.2	Diagnostic and Reset considerations	56
10.3	Sector Addressing Mode	57
10.3.1	Logical CHS Addressing Mode	57
10.3.2	LBA Addressing Mode	57
10.4	Power Management Feature	58
10.4.1	Power Mode	58
10.4.2	Power Management Commands	58
10.4.3	Standby/Sleep command completion timing	58
10.4.4	Standby timer	59
10.4.5	Status	59
10.4.6	Interface Capability for Power Modes	59
10.4.7	Initial Power Mode at Power On	59
10.5	Adaptive Power Management Feature	60
10.5.1	Performance Idle mode	60
10.5.2	Low Power (LP) Idle mode	60
10.5.3	Transition Time	60
10.6	S.M.A.R.T. Function	61
10.6.1	Attributes	61
10.6.2	Attribute values	61
10.6.3	Attribute thresholds	61
10.6.4	Threshold exceeded condition	61
10.6.5	S.M.A.R.T. commands	61
10.6.6	S.M.A.R.T. operation with power management modes	62
10.7	Security Mode Feature Set	63
10.7.1	Security mode	63
10.7.2	Security level	63
10.7.3	Password	63
10.7.4	Operation example	64
10.7.5	Command Table	67
10.8	Protected Area Function (Vendor Specific)	69
10.8.1	Example for operation (In LBA mode)	69
10.9	Write Cache Function	70
10.10	Reassign Function	71
10.10.1	Auto Reassign Function	71
<b>11.0</b>	<b>Command Protocol</b>	<b>73</b>
11.1	Data In Commands	73
11.2	Data Out Commands	74
11.3	Non-Data Commands	76
11.4	DMA Data Transfer Commands	77
<b>12.0</b>	<b>Command Descriptions</b>	<b>79</b>
12.1	Check Power Mode (E5h/98h)	83
12.2	Execute Device Diagnostic (90h)	84
12.3	Format Track (50h: Vendor Specific)	85
12.4	Format Unit (F7h: Vendor Specific)	88
12.5	Identify Device (ECh)	89

12.6	Identify Device DMA (EEh)	93
12.7	Idle (E3h/97h)	94
12.8	Idle Immediate (E1h/95h)	95
12.9	Initialize Device Parameters (91h)	96
12.10	Read Buffer (E4h)	97
12.11	Read DMA (C8h/C9h)	98
12.12	Read Long (22h/23h)	100
12.13	Read Multiple (C4h)	102
12.14	Read Native Max LBA/CYL (F8h: Vendor Specific)	104
12.15	Read Sectors (20h/21h)	106
12.16	Read Verify Sectors (40h/41h)	108
12.17	Recalibrate (1xh)	110
12.18	Security Disable Password (F6h)	111
12.19	Security Erase Prepare (F3h)	112
12.20	Security Erase Unit (F4h)	113
12.21	Security Freeze Lock (F5h)	115
12.22	Security Set Password (F1h)	116
12.23	Security Unlock (F2h)	118
12.24	Seek (7xh)	120
12.25	Set Features (EFh)	121
12.26	Set Max LBA/CYL (F9h: Vendor Specific)	123
12.27	Set Multiple (C6h)	125
12.28	Sleep (E6h/99h)	126
12.29	S.M.A.R.T. Function Set (B0h)	127
12.29.2	Device Attributes Data Structure	130
12.29.3	Device Attribute Thresholds Data Structure	136
12.29.4	Error Reporting	138
12.30	Standby (E2h/96h)	140
12.31	Standby Immediate (E0h/94h)	141
12.32	Write Buffer (E8h)	142
12.33	Write DMA (CAh/CBh)	143
12.34	Write Long (32h/33h)	145
12.35	Write Multiple (C5h)	147
12.36	Write Sectors (30h/31h)	149
12.37	Write Verify (3Ch: Vendor Specific)	151
<b>13.0</b>	<b>Timings</b>	<b>153</b>
<b>14.0</b>	<b>Appendix</b>	<b>157</b>
14.1	Commands Support Coverage	157
14.2	SET FEATURES Command Support Coverage	160
14.3	Changed Points from DSOA-2xxxx	161
14.3.1	Added Points	161
14.3.2	Changed Points	161
14.3.3	Deleted Points	161
<b>Index</b>		<b>163</b>

---

## 1.0 General

This document describes the specifications of the following IBM 2.5-inch, ATA interface hard disk drives:

- DMCA-21080 (1080 MB)
- DMCA-21440 (1440 MB)

**Note:** The specifications are subject to change without notice.

---

## 1.1 Glossary

<i>Word</i>	<i>Meaning</i>
<b>Kbpi</b>	1 000 Bit Per Inch
<b>Mbps</b>	1 000 000 Bit per second
<b>MB</b>	1 000 000 bytes
<b>KB</b>	1 000 bytes
<b>32 KB</b>	32 x 1 024 bytes
<b>64 KB</b>	64 x 1 024 bytes
<b>Mb/sq.in</b>	1 000 000 bits per square inch
<b>MLC</b>	Machine Level Control
<b>TBD</b>	To Be Defined

---

## 1.2 General Caution

- Do not apply pressing force on the top cover (See Figure 1 on page 2).
- Do not cover the breathing hole on the top cover (See Figure 2 on page 3).
- Do not touch the interface connector pins and the surface of printed circuit board.
- The drive can be easily damaged by shocks or ESD (Electric Static Discharge), so any damages applied to the drive after taking out from shipping package and opening ESD protective bag are user's responsibilities.

## 1.2.1 Caution of usage

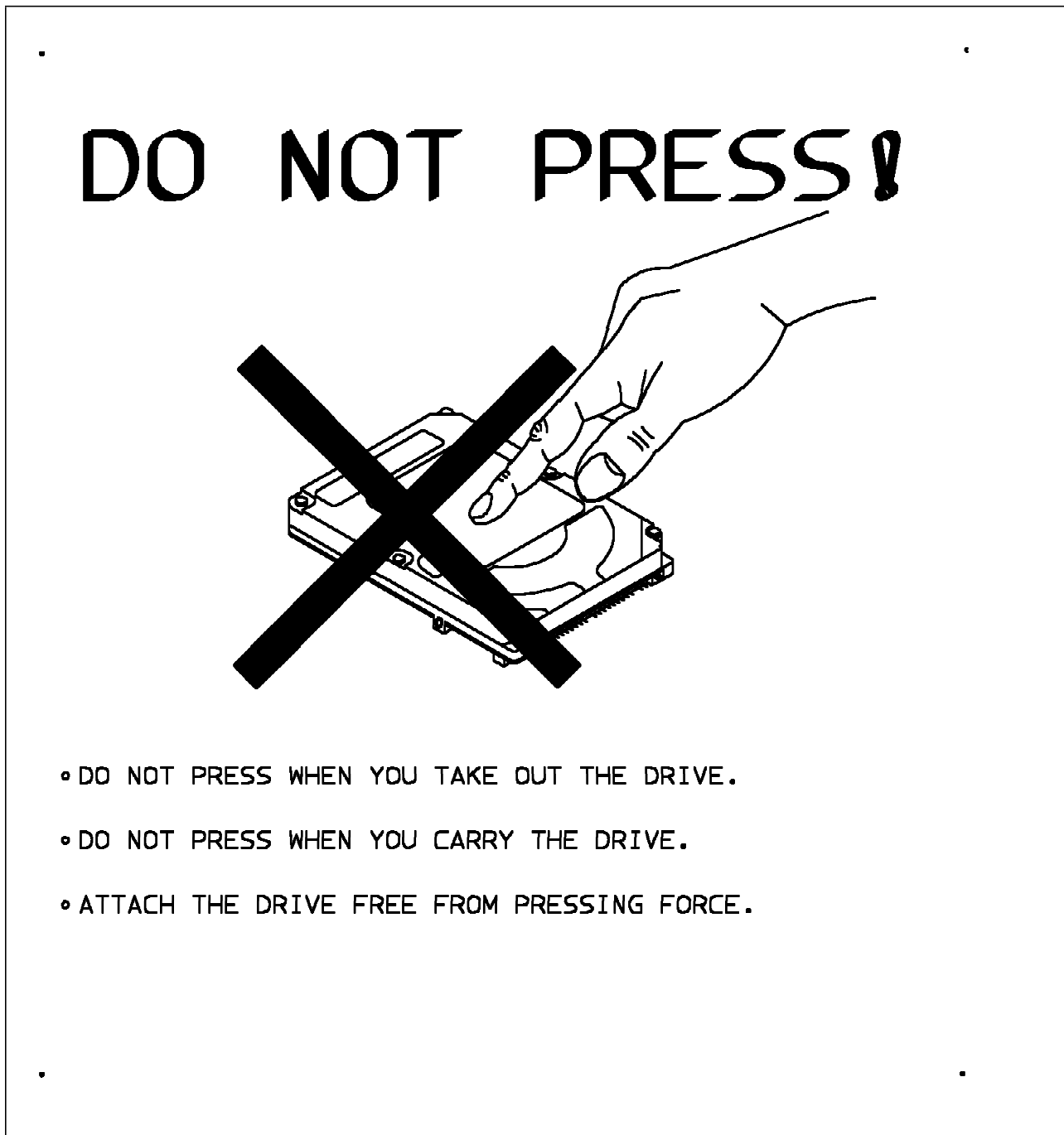

Figure 1. Handling and attachment caution of DMCA-21080/21440

# DO NOT COVER THIS HOLE

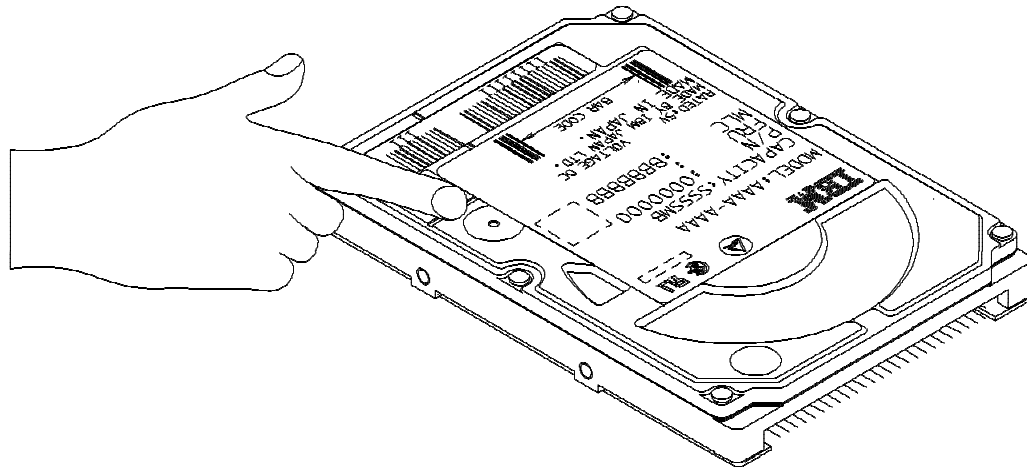

Figure 2. Breathing hole caution of DMCA-21080/21440



---

## 2.0 General Features

- 2.5-inch, 12.5mm Height MCC Compliance
- 1080MB and 1440MB formatted capacity
- 512 bytes/sector
- AT Interface (Enhanced IDE) conforming to ATA-3
- Integrated controller
- No-ID recording format
- PRML channel
- Multi Zone Recording
- Enhanced ECC
  - On The Fly correction : 6 Bytes/sector
  - Offline correction : 9 Bytes/sector
- 96KB Segmented Buffer with Write Cache
- | • PIO Data Transfer - Mode 4 (16.6 MB/sec)
- | • DMA Data Transfer
  - | – Single Word mode : Mode 2 (8.3MB/sec)
  - | – Multiword mode : Mode 2 version (16.6 MB/sec) / Mode 1 version<sup>1</sup> (8.3 MB/sec)
- Media data transfer rate 61.0(outer zone) - 40.0(inner zone) Mbit/se
- Average seek time 13 milliseconds for read
- Closed-loop actuator servo (Embedded Sector Servo)
- Rotary voice coil motor actuator
- Automatic Actuator lock
- Dedicated head landing zone
- Adaptive power save control (0.85 Watt at low-power idle state)
- 2.3 sec Power on to ready
- Shock
  - Non-operation : 500G/2ms
  - Operation : 100G/2ms

---

| <sup>1</sup> See Note 4 in 12.5, “ Identify Device (ECh)” on page 89.



---

## Part 1. Functional Specification



---

## 3.0 Drive Characteristics

This chapter provides the characteristics of the drives.

---

### 3.1 Logical Drive Format

The customer usable data capacity is as shown below.

Figure 3. Drive Parameter		
Descriptions	DMCA-21080	DMCA-21440
Logical Head Number	16	16
Logical Sectors/Track	63	63
Logical Cylinder Number	2100	2800
Logical Sector Size	512	512
Total Customer Usable Data Sectors	2 116 800	2 822 400
Total Customer Usable Data Bytes	1080 MB (1,083,801,600)	1440 MB (1,445,068,800)

---

### 3.2 Data Sheet

Figure 4. Data Sheet	
Media transfer rate [Mb/sec]	39.5 - 61.8
Interface transfer rate [MB/sec]	16.6 MB/sec Max
Data buffer size [KB]	96 KB (Read/Write)
Rotational speed [RPM]	4000
Average latency [msec]	7.5
Recording density [Kbpi]	152.5 Maximum
Track density [TPI]	8600
Areal density [Gb/sq.in.]	1.31 Maximum
Number of zone	8
Number of disks	2
Servo design method	Embedded sector servo

---

## 3.3 Performance Characteristics

File performance is characterized by the following parameters:

- Command Overhead
- Mechanical Positioning
  - Seek Time
  - Latency
- Data Transfer Speed
- Buffering Operation

**Note:** All the above parameters contribute to a file performance. There are other parameters which contribute to the performance on the actual system. This specification tries to define the essential file characteristics, not the system throughput which is dependent on the system and the application.

The following table gives a **typical value** of each parameter. The detail descriptions are followed in the next sections.

Function	Typical
Average Random Seek Time For Read	13 msec
Average Random Seek Time For Write	14 msec
Rotational Speed	4000 rpm
Power On To Ready	2.3 sec
Command Overhead	1.0 msec
Disk-Buffer Data Transfer	61.8 - 39.5 Mbit/sec
Buffer-Host Data Transfer	16.6 MB/sec

Figure 5. Performance Parameter

### 3.3.1 Command Processing

Command overhead time is defined as the total time from when the command is received by the drive to the start of motion of the actuator.

### 3.3.2 Average Seek Time (Including Settling)

Command Type	Typical	Max
Read	13 msec	16 msec
Write	14 msec	17 msec

Figure 6. Mechanical Positioning Performance

'Typical' and 'Max' are given throughout the performance specification by;

**Typical** Average of the drive population tested at nominal environmental and voltage conditions.

**Max** Maximum value measured on any one drive over the full range of the environmental and voltage conditions. (See section on Environment and D.C. Power Requirements.)

The seek time is measured from the start of motion of the actuator to the start of a **reliable read or write operation**. Reliable read or write implies that error correction/recovery is not employed to correct for arrival problems. The Average Seek Time is measured as the weighted average of all possible seek combinations.

$$\text{Weighted Average} = \frac{\sum_{n=1}^{\text{max}} (\text{max} + 1 - n) (T_{n.in} + T_{n.out})}{(\text{max} + 1) (\text{max})}$$

Where:

- max = Maximum Seek Length
- n = Seek Length ( 1 to max )
- Tn.in = Inward measured seek time for a n track seek
- Tn.out = Outward measured seek time for a n track seek

### 3.3.3 Single Track Seek Time

Function	Typical	Max
READ	4 msec	5.5 msec
Write	4 msec	6.5 msec

Figure 7. Single Track Seek Time

Single track seek is measured as the average of one (1) single track seek from every track in both directions (inward and outward).

### 3.3.4 Full Stroke Seek

Function	Typical	Max
Read	23.0 msec	30.0 msec
Write	24.0 msec	31.0 msec

Figure 8. Full Stroke Seek Time

Full stroke seek is measured as the average of 1000 full stroke seeks.

### 3.3.5 Average Latency

RPM	Time for a revolution	Average Latency
4000	15.0 msec	7.5 msec

Figure 9. Latency Time

### 3.3.6 Drive Ready Time

Condition	Typical	Max
Power On To Ready	2.3 sec	9.5 sec

Figure 10. Drive Ready Time

**Ready** The condition in which the drive is able to perform a media access command (e.g. read, write) immediately.

**Power On** This includes the time required for the internal self diagnostics.

### 3.3.7 Operating Modes.

Operating mode	Description
Spin-Up	: Start up time period from spindle stop or power down.
Seek	: Seek operation mode
Write	: Write operation mode
Read	: Read operation mode
Active	: The device is capable of responding immediately to media access requests, and commands complete execution in the shortest possible time.
Idle	: The device is capable of responding immediately to media access requests. Some circuitry including servo system and R/W electronics are in power saving mode. A device in Idle mode may take longer to complete the execution of a command because it have to activate those circuitry.
Standby	: The device interface is capable of accepting commands. Spindle motor is stopped. All circuitry except host interface are in power saving mode. The execution of commands is delayed until spindle become ready.
Sleep	: The device requires a soft reset or a hard reset to be activated. All electronics including spindle motor and host interface are shut off.
Note-1	: Upon power down or Spindle stopped, a head locking mechanism will secure the heads in the ID parking position.

Figure 11. Operating Mode

#### 3.3.7.1 Mode Transition Time.

From	To	Transition Time
Standby	Idle	2.3 sec typ, 9.5 sec max.
Idle	Standby	2.2 sec typ, 5.5 sec max.

Figure 12. Mode Transition Time

### **3.3.7.2 Operating mode at power on**

The device goes to Idle mode after power on or hard reset as an initial state. Initial state may be changed to Standby mode using pin 47 on the interface connector. Refer to 6.7, “ Drive Address Setting” on page 39 for detail.

### **3.3.7.3 Adaptive power save control**

The transient timing from active mode to Idle mode is adaptively controlled to the access pattern of the host system.

---

## 4.0 Data Integrity

---

### 4.1 Data Loss by Power Off

- The drive retains recorded data under all non-write operation.
- No more than one sector can be lost by power down during write operation while write cache is disabled.
- Power off during write operation may make an incomplete sector which will report hard data error when read. The sector can be recovered by a re-write operation.
- Hard reset does not cause any data loss.

---

### 4.2 Write Cache

- Power off while write cache is enabled may cause loss of data which are remaining in the cache and have not been flushed onto the disk media.  
This means that there is a possibility that power off even after write command completion may cause loss of data.
- There are three ways to check if all data in the write cache have been flushed onto the disk. Checking just before power off is recommended to prevent data loss.
  - To confirm negation of -DASP signal.
  - To confirm successful completion of Software Reset.
  - To confirm successful completion of Check Power Mode commands.

---

### 4.3 Equipment Status

Equipment status is available to the host system any time the drive is not ready to read, write, or seek. This status normally exists at power-on time and will be maintained until the following conditions are satisfied:

- Access recalibration/tuning is complete.
- Spindle speed meets requirements for reliable operation.
- Self-check of drive is complete.

Appropriate error status is made available to the host system if any of the following conditions occur after the drive has once become ready:

- Spindle speed outside requirements for reliable operation.
- Occurrence of a WRITE FAULT condition.

---

## 4.4 WRITE Safety

The verification process of write operation usually involves a read back check of the ECC in conjunction with WRITE FAULT detection circuits. The WRITE FAULT detection circuits reveal conditions where a write operation was intended and did not occur properly and the ECC verification occurred for old information.

---

## 4.5 Data buffer test

The data buffer is tested at Power-on-reset and when a drive self-test is requested by the host. The tests are consisted of write/read '00'x and 'ff'x pattern on all buffer.

---

## 4.6 Error Recovery

Errors occurring on the drive are handled by the error recovery procedure.

Errors that are uncorrectable after application of the error recovery procedures are reported to the host system as non-recoverable errors.

---

## 4.7 Automatic Reallocation

The sectors those show some errors may be reallocated automatically when specific conditions are met. The spare sectors for reallocation are located at the end of drive. As a result of reallocation, the physical location of logically sequenced sectors will be dispersed. The drive does not report for auto-reallocation to the host system. The conditions for auto-reallocation are described below.

### 4.7.1 Non Recovered Write Errors

When a write operation can not be completed after the Error Recovery Procedure (ERP) is fully carried out, the sector(s) are reallocated to the spare location. An error is reported to the host system only when the write cache is disabled and the auto reallocation is failed.

### 4.7.2 Non Recovered Read Errors

When a read operation is failed after defined ERP is fully carried out, a hard error is reported to the host system. This location is registered internally as a candidate for the reallocation. When a registered location is specified as a target of a write operation, a sequence of media verification is performed automatically. When the result of this verification meets the criteria, this sector is reallocated.

### 4.7.3 Recovered Read Errors

When a read operation for a sector failed once then recovered at the specific ERP step, this sector is reallocated automatically. A media verification sequence may be run prior to the reallocation according to the pre-defined conditions.

## 5.0 Specification

### 5.1 Environment

#### 5.1.1 Temperature and Humidity

Figure 13. Environmental Condition	
Operating Conditions	
Temperature	5 to 55[°C] (See note)
Relative Humidity	8 to 90 [% RH] non-condensing
Maximum Wet Bulb Temperature	29.4[°C] non-condensing
Maximum Temperature Gradient	15[°C / Hour]
Altitude	- 300 to 3048 [m]
Non-Operating Conditions	
Temperature	- 40 to 65[°C]
Relative Humidity	5 to 95 [% RH] non-condensing
Maximum Wet Bulb Temperature	40[°C] non-condensing
Maximum Temperature Gradient	15[°C / Hour]
Altitude	- 300 to 12,000 [m]
<b>Note:</b>	
The system has to provide sufficient ventilation to maintain a surface temperature below 60[°C] at the center of the top cover of the drive.	
Non-operating condition should not continue beyond one year.	

## 5.1.2 Magnetic Fields

The disk drive will withstand the radiation & conductive noise limit shown below.

### 5.1.2.1 Radiation Noise

The disk drive shall work without degradation of the soft error rate under the following Magnetic Flux Density Limits at the enclosure surface.

Frequency ( KHz )	Limits ( Gauss rms )
0 - 60	5.0
61 - 100	2.5
101 - 200	1.0
201 - 400	0.5

Figure 14. Magnetic Flux Density Limits

### 5.1.2.2 Conductive Noise

The disk drive shall work without degradation of the soft error rate, with an AC current of up to 45 mA(p-p), in the frequency range from DC to 20 MHz, injected through any two of the mounting screw holes of the drive via 50ohm resistor.

## 5.2 DC Power Requirements

Connection to the product should be made in isolated secondary circuits (SELV). The voltage specifications are applied at the power connector of the drive.

Item	Requirements	Notes
Nominal Supply	+ 5 Volt	
Power Supply Ripple ( 0- 20Mhz)	100 mv p-p max	*1
Tolerance	+/- 5 %	*2
Supply Current	Pop.Mean (Nominal Condition)	
Idle average (Low-power idle)	0.17 A RMS max (0.85W)	*3
Idle average (Performance idle)	0.34 A RMS max (1.7W)	
Read / Write	0.46 A RMS max (2.3W)	*4
Seek average	0.46 A RMS max (2.3W)	*5
Standby	0.06 A RMS max (0.3W)	
Sleep	0.02 A RMS max (0.1W)	
Start up(maximum peak)	0.94 A RMS max (4.7W)	*6
(average from power on to ready)	0.70 A RMS max (3.5W)	*7
Supply Rise Time	7 - 100 ms	

Figure 15. Power Requirement

Notes (\*):

- (\*1) The maximum fixed disk ripple is measured at 5V input of the drive.
- (\*2) The disk drive shall not incur damage for an over voltage condition of +25 % (maximum duration of 20 ms) on the 5-volt nominal supply.
- (\*3) The idle current is specified at an inner track.
- (\*4) The read/write current is specified based on three operations of 63 sector read/write per 100 msec.
- (\*5) The seek average current is specified based on three operations per 100 msec.
- (\*6) Typical start up current is shown in 5.2.1, “ Start Up Current” on page 20.
- (\*7) The typical current wave form at start up is shown in Figure 16 on page 20.

## 5.2.1 Start Up Current

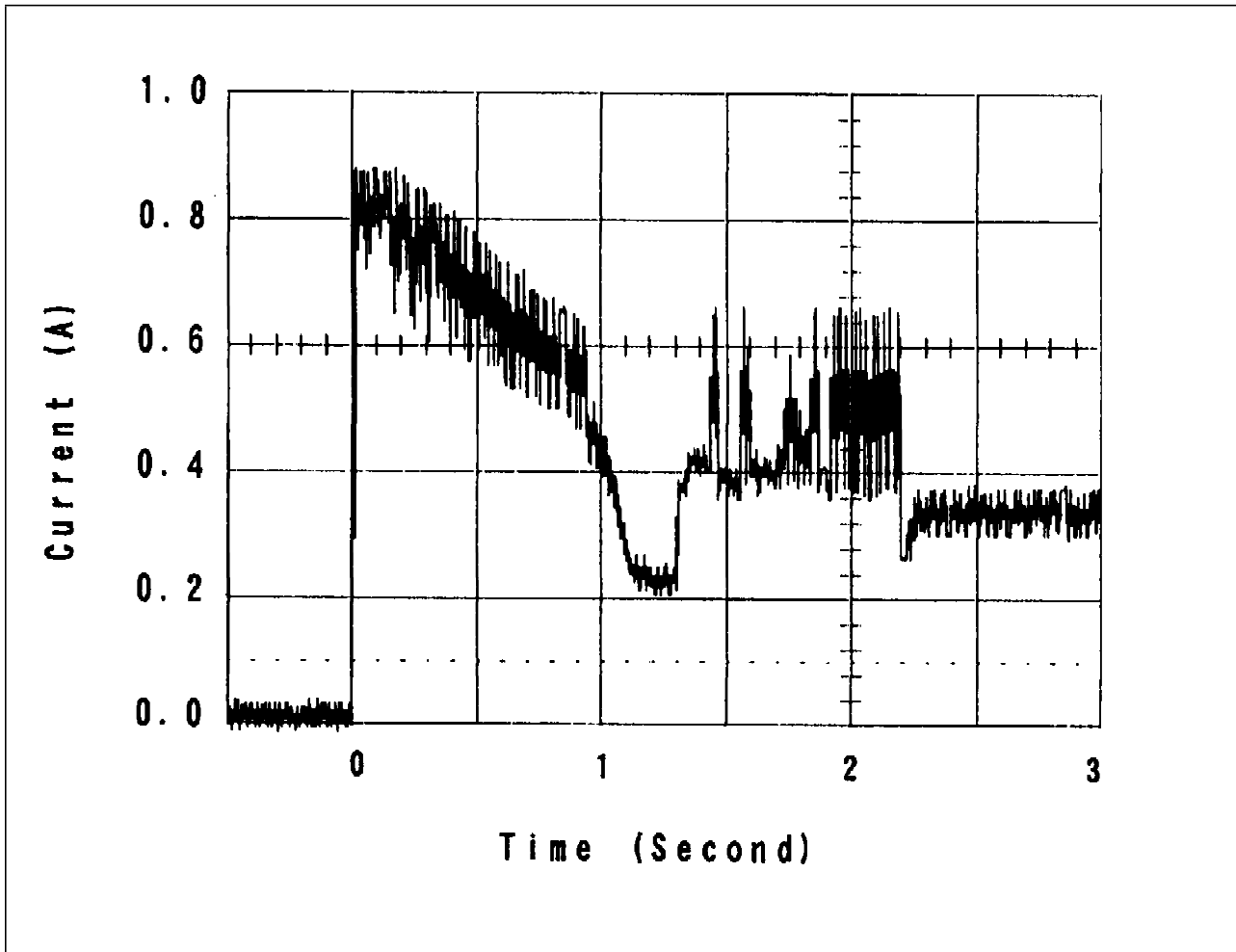

Figure 16. Typical current wave form at start up

---

## 5.3 Reliability

### 5.3.1 Contact Start Stop (CSS)

The drive is designed to withstand a minimum of 52,000 contact start/stop cycles under 40°C with 15-20% humidity.

The drive is designed to withstand a minimum of 10,400 contact start/stop cycles under 55°C with 8-15% humidity.

### 5.3.2 Preventive Maintenance

None.

### 5.3.3 Data Reliability

- Probability of not recovering data ..... 1 in 10<sup>13</sup> bits read
- ECC implementation
  - On-The-Fly correction, performed as a part of read channel function, recovers up to 6 symbols of error in 1 sector. (1 symbol is 8 bits.)
  - Off-line correction, performed as a part of retry procedure in the drive, recovers up to 9 symbols of error in 1 sector.

### 5.3.4 Failure Prediction ( S.M.A.R.T.)

DMCA-2xxxx supports S.M.A.R.T. function. The details are described in 10.6, “ S.M.A.R.T. Function” on page 61.

### 5.3.5 Cable Noise Interference

To avoid any degradation of performance throughput or error when the interface cable is routed on top or comes in contact with the HDA assembly, the drive must be grounded electrically to the system frame by four screws. The common mode noise or voltage level difference between the system frame and power cable ground or AT interface cable ground should be in the allowable level specified in the power requirement section.

---

## 5.4 Mechanical Specifications

### 5.4.1 Mechanical Dimensions and Weight

The following chart describes the dimensions for the 2.5" hard disk drive form factor.

	<b>DMCA-21080</b>	<b>DMCA-21440</b>
Height (mm)	12.5 +0.2/-0.3	12.5 +0.2/-0.3
Width (mm)	69.85 ± 0.25	69.85 ± 0.25
Length (mm)	100.2 ± 0.25	100.2 ± 0.25
Weight (gram)	140 Max	140 Max

Figure 17. Physical Dimension and Weight

### 5.4.2 Hole Locations

The Figure 18 on page 23 shows the outline of DMCA-21080/21440 which includes the hole locations.

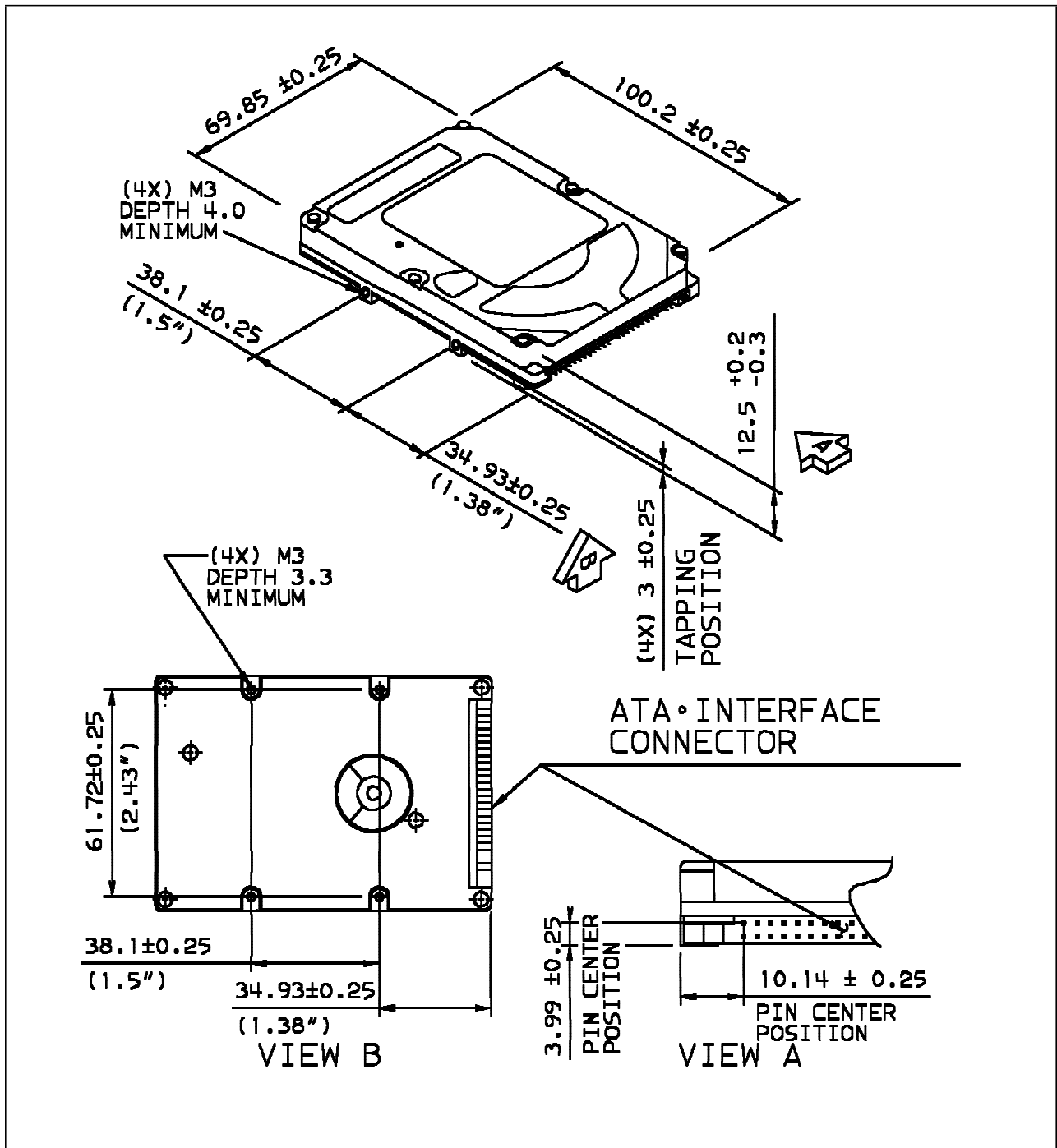

Figure 18. Outline of DMCA-21080/21440

### **5.4.3 Mounting Orientation**

The drive will operate in all axes (6 directions). The drive will operate within the specified error rates when tilted  $\pm 5$  degree from these positions.

Performance and error rate will stay within specification limits if the drive is operated in the other permissible orientations from which it was formatted. Thus a drive formatted in a horizontal orientation will be able to run vertically and vice versa.

The recommended mounting screw torque is 3 +/- 0.5 kgf.cm.

The recommended mounting screw depth is 3.0 +/- 0.3 mm for bottom and 3.5 +/- 0.5 mm for horizontal mounting.

The system is responsible for mounting the drive securely enough to prevent from excessive motion or vibration of the drive at seek operation or spindle rotation, using appropriate screws or equivalent mounting hardware.

Vibration test and shock test are to be conducted by mounting the drive to the table using bottom four screws.

### **5.4.4 Shipping Zone and Lock**

A "shipping" (or "landing") zone on the disk, not on the data area of the disk, is provided to protect the disk data during shipping, movement, or storage. Upon power down, a head locking mechanism will secure the heads in this zone. See Non-Operating Shock section for additional details.

---

## 5.5 Vibration and Shock

All vibration and shock measurements in this section shall be for the disk drive without the mounting attachments for the systems. The input level shall be applied to the normal drive mounting points.

### 5.5.1 Operating Vibration

The disk drive will operate without a hard error while being subjected to the following vibration levels.

The test will be 30 minutes of random vibration using the power spectral density (PSD) levels shown below. The vibration test level is 0.67G RMS (Root Mean Square).

Random vibration PSD profile Breakpoint

5 Hz	2.0 x E-5	g**2/Hz
17 Hz	1.1 x E-3	
45 Hz	1.1 x E-3	
48 Hz	8.0 x E-3	
62 Hz	8.0 x E-3	
65 Hz	1.0 x E-3	
150 Hz	1.0 x E-3	
200 Hz	5.0 x E-4	
500 Hz	5.0 x E-4	

The specified levels are measured at the mounting points.

### 5.5.2 Non-Operating Vibrations

#### 5.5.2.1 Random Vibration

The test consists of a random vibration applied in each of three mutually perpendicular axes with the time duration of 15 minutes per axis. The PSD levels for the test simulates the shipping and relocation environment which is shown below.

Figure 19. Random Vibration PSD Profile Breakpoints (Non-Operating)							
Hz	Random Vibration PSD Profile Breakpoints (Non-Operating)						
Hz	2	4	8	40	55	70	200
G**2/Hz	0.001	0.03	0.03	0.003	0.01	0.01	0.001

Overall RMS level of vibration is 1.04G (RMS).

#### 5.5.2.2 Swept Sine Vibration

- 2 G (Zero to peak), 5 to 200 to 5 Hz sine wave
- 0.5 oct/min sweep rate
- 15 minutes dwell at two major resonances

### **5.5.3 Operating Shock**

The hard disk drive meets the following criteria while operating in the conditions described below. The shock test consists of ten shock inputs in each axis and direction for a total of 60. There must be a minimum 3 seconds delay between shock pulses. Soft errors and automatic retries are allowed during the test.

No data loss or permanent damage : 100G, 2 msec half-sine shock pulse, 10G/11msec half-sine shock pulse

The input level shall be applied to the normal disk drive subsystem mounting points, as mounted in normal system use.

### **5.5.4 Non-Operating Shock**

The disk drive must withstand with no damage or degradation of performance, a 120G half-sine wave shock pulse of 11 ms duration and a 500G half-sine wave shock pulse of 2 ms duration on six sides when heads are parked. (When the power is not applied to the unit, the heads are automatically located on the parked position.)

All shocks shall be applied in each direction of the drive's three mutually perpendicular axes, one axis at a time. Input levels shall be measured at the frame of the disk drive.

## 5.6 Acoustics

### 5.6.1 Sound Power Levels

The upper limit criteria of the octave sound power levels are given in Bels relative to 1 pico Watt and are shown in the following table with A-weighted levels.

Figure 20. Octave band sound power levels								
	Octave Band Center Frequency (Hz)							
Mode	125	250	500	1k	2k	4k	8k	LwAu
Idle	4.8	4.1	3.6	3.6	3.9	3.9	3.6	4.5
Operating	5.0	4.3	4.2	4.2	4.2	4.2	3.8	4.8

Background power levels of the acoustic test chamber for each octave band are to be recorded.

Sound power tests are to be conducted with the drive supported by spacers so that the lower surface of the drive be located at 25 +/- 3mm height from the chamber floor. No sound absorbing material shall be used.

The acoustical characteristics of the disk drive subsystem are measured under the following conditions.

Idle mode :

Power on, disks spinning, track following, unit ready to receive and respond to control line commands.

Operating mode :

Continuous random cylinder selection and seek operation of actuator with a dwell time at each cylinder. Seek rate for the drive can be calculated as shown below.

$$\text{Dwell time} = (0.5 + N) \times 60/\text{RPM}$$

$$\text{Seek rate} = 1/(\text{Average seek time} + \text{Dwell time})$$

Where N = number of maximum data surfaces (n=4 for DMCA-21440)

### 5.6.2 Sound Power Acceptance Criteria

Statistical upper limit  $(L_{W_{\text{oct}}})_{\text{stat}}$  is calculated with following formula.

$$(L_{W_{\text{oct}}})_{\text{stat}} = (L_{W_{\text{oct}}})_{\text{m}} + k \times (s_t)_{W_{\text{oct}}}$$

where:

$(L_{W_{\text{oct}}})_{\text{m}}$  is the mean value of the sound power level for a sample of N drives.

$(s_t)_{W_{\text{oct}}}$  is the total standard deviation for sound power level at each octave band.

$$(s_t)_{W_{\text{oct}}} = \text{SQRT}((s_R)_W^2 + (s_P)_{W_{\text{oct}}}^2)$$

$(s_R)_W$  is the standard deviation of reproducibility for sound power level.

Assume  $(s_R)_W = 0.075$  B.

$(s_P)_{W_{\text{oct}}}$  is the standard deviation of the samples for sound power level at each octave band.

k is a coefficient determined by number of samples (N) as shown below.

N	3	4	5	6	7	8	9	10	11	12	13	14	15
k	3.19	2.74	2.74	2.49	2.33	2.22	2.13	2.07	2.01	1.97	1.93	1.90	1.87

The calculated left hand side of the criterion equation above is referred to as LWU and is rounded to the nearest 0.05 bel. The individual terms may be rounded to the nearest 0.01 bel before calculation.

---

## 5.7 Identification

### 5.7.1 Labels

The following labels are affixed to every disk drive .

1. A label containing IBM logo, IBM part number and the statement 'Made by IBM' or equivalent.
2. A label containing drive model number, date code, formatted capacity, place of manufacture, and UL/CSA/TUV/CE mark logos.
3. A bar code label containing the drive serial number.

The labels may be integrated with other labels.

---

## 5.8 Electromagnetic Compatibility

The drive, when installed in a suitable enclosure and exercised with a random accessing routine at maximum data rate, shall meet the worldwide EMC requirements listed below.

IBM will provide technical support to assist users in complying with the EMC requirements.

- United States Federal Communications Commission (FCC) Rules and Regulations (Class B), Part 15.
- European Economic Community (EEC) directive number 76/889 related to the control of radio frequency interference and the Verband Deutscher Elektrotechniker (VDE) requirements of Germany (GOP).

### 5.8.1 CE Mark

The product is declared to be in conformity with the requirements of following EC directives under the sole responsibility of IBM United Kingdom Ltd.

Council Directive 89/336/EEC on the approximation of laws of the Member States relating to electromagnetic compatibility.

---

## **5.9 Safety**

### **5.9.1 Underwriters Lab(UL) Approval**

DMCA-21080/21440 complies with UL 1950.

### **5.9.2 Canadian Standards Authority(CSA) Approval**

DMCA-21080/21440 complies with CSA C22.2, #950-M89.

### **5.9.3 IEC Compliance**

DMCA-21080/21440 complies with IEC 950.

### **5.9.4 German Safety Mark**

DMCA-21080/21440 are approved by TUV on Test Requirement:

EN 60 950:1988/A1:1990/A2:1991.

### **5.9.5 Flammability**

Printed Circuit boards used in this product are made of material with a UL recognized flammability rating of V-1 or better. The flammability rating is marked or etched on the board. All other parts not considered electrical components are made of material with a UL recognized flammability rating of V-1 or better except minor mechanical parts.

### **5.9.6 Secondary Circuit Protection**

This product utilizes printed circuit wiring that must be protected against the possibility of sustained combustion due to circuit or component failure. Adequate secondary over current protection is the responsibility of the using system.

User must protect the drive from it's electrical short circuit problem. 10 A limit is required for safety purpose.

---

## **5.10 Packaging**

Drives will be shipped in appropriate containers and placed on pallets.

Drives are shipped in ESD protective bags.



## 6.3 Signal Definition

The pin assignments of interface signals are listed as follows:

PIN	SIGNAL	I/O	Type	PIN	SIGNAL	I/O	Type
01	-HRESET	I	TTL	02	GND		
03	HD07	I/O	3-state	04	HD08	I/O	3-state
05	HD06	I/O	3-state	06	HD09	I/O	3-state
07	HD05	I/O	3-state	08	HD10	I/O	3-state
09	HD04	I/O	3-state	10	HD11	I/O	3-state
11	HD03	I/O	3-state	12	HD12	I/O	3-state
13	HD02	I/O	3-state	14	HD13	I/O	3-state
15	HD01	I/O	3-state	16	HD14	I/O	3-state
17	HD00	I/O	3-state	18	HD15	I/O	3-state
19	GND			(20)	Key		
21	DMARQ	O	3-state	22	GND		
23	-HIOW	I	TTL	24	GND		
25	-HIOR	I	TTL	26	GND		
27	HIORDY	O	OD	28	CSEL	I	TTL
29	-DMACK	I	TTL	30	GND		
31	HIRQ	O	3-state	32	-HIOCS16	O	OD
33	HA01	I	TTL	34	-PDIAG	I/O	OD
35	HA00	I	TTL	36	HA02	I	TTL
37	-HCS0	I	TTL	38	-HCS1	I	TTL
39	-DASP	I/O	OD	40	GND		
41	+5V Logic	PWR		42	+5V MOTOR	PWR	
43	GND			44	(Resv)		

Figure 22. Table of Signals

### Notes:

1. "O" designates an output from the Drive.
2. "I" designates an input to the Drive.
3. "I/O" designates an input/output common.
4. "PWR" designates a power supply to the Drive.
5. "OD" designates Open-Drain output.
6. "(Resv)" designates reserved pins and all of these have to be left unconnected.

---

## 6.4 Signal Description

- HD00-HD15** 16-bit bi-directional data bus between the host and the drive. The lower 8 lines, HD00-07, are used for Register and ECC access. All 16 lines, HD00-15, are used for data transfer. These are Three-State lines that have a 24 mA current sink capability.
- HA00-HA02** Address used to select the individual register in the drive.
- HCS0** Chip select signal generated from the Host address bus. When active, one of the Command Block Registers (Data, Error{Features when written}, Sector Count, Sector Number, Cylinder Low, Cylinder High, Drive/Head and Status{Command when written} register) can be selected.  
(See Figure 28 on page 40.)
- HCS1** Chip select signal generated from the Host address bus. When active, one of the Control Block Registers (Alternate Status{Device Control when written} and Drive Address register) can be selected.  
(See Figure 28 on page 40.)
- HRESET** This line is used to reset the drive. It shall be kept at a Low logic state during power up and kept High thereafter for normal operation.
- HIOW** The rising edge clocks data from the host data bus to a register or data register of the drive.
- HIOR** When low, this signal enables data from a register or data register of the drive onto data bus. The data on the bus shall be latched on the rising edge of -HIOR.
- HIRQ** Interrupt is enabled only when the drive is selected, and the host activates the -IEN bit in the Device Control Reg. Otherwise, this signal is in high impedance state regardless of the state of the IRQ bit. The interrupt is set when the IRQ bit is set by the drive CPU. IRQ is reset to zero by a host read of the status register or a write to the Command Reg. This signal is a 3-State line with 24 mA sink capability.
- IORDY** Indication to host that the drive is ready to complete current I/O cycle. This line is driven low at the falling edge of -HIOR or -HIOW, when the drive needs some additional WAIT cycle(s) to extend PIO cycle. This line can be connected to host IORDY signal in order to insert WAIT state(s) in the host PIO cycle. This is an Open-Drain output with 24 mA sink capability.
- CSEL** This signal is monitored to determine the drive address, Master or Slave, when the jumper on the interface connector is at Position-3. (Refer to Figure 27 on page 39 for jumper position.)  
When CSEL is ground or at a low level, the drive works as a Master. If CSEL is open or a high level, the drive works as a Slave.  
The signal level of CSEL to one drive should be different from the signal level to another drive on the same AT interface cable, to avoid master-master or slave-slave configurations. Signal level of CSEL should be constant while the drives are on the AT interface.
- HIOCS16** Indication to the host that 16-bit wide data register has been addressed and that the drive is prepared to send or receive a 16-bit wide data word. This signal is an Open-Drain output with 24 mA sink capability and an external resistor is needed to pull this line to 5 Volt.
- DASP** This is a time-multiplexed signal which indicates that a drive is active, or that drive 1 is present. This signal is driven by an Open Collector driver and internally pulled-up to 5 Volt through 10Kohm resistor.  
During Power-On initialization or after -RESET is negated, -DASP shall be asserted by Drive 1 within 400 msec to indicate that drive 1 is present. Drive 0 shall allow up to

450msec for drive 1 to assert -DASP. If drive 1 is not present, drive 0 may assert -DASP to drive a LED indicator.

-DASP shall be negated following acceptance of the first valid command by drive 1 or after 31 seconds, whichever comes first.

Anytime after negation of -DASP, either drive may assert -DASP to indicate that a drive is active.

When write cache is enabled, drive asserts -DASP until completion of actual disk write operation.

#### **-PDIAG**

This signal shall be asserted by drive 1 to indicate to drive 0 that it has completed diagnostics. This line is pulled-up to 5 Volt in the drive through a 10Kohm resistor.

Following a Power On Reset, software reset or -HRESET, drive 1 shall negate -PDIAG within 1 msec (to indicate to drive 0 that it is busy). Drive 1 shall then assert -PDIAG within 30 seconds to indicate that it is no longer busy, and is able to provide status. After the assertion of -PDIAG, drive 1 may be unable to accept commands until it has finished its reset procedure and is ready (DRDY=1).

Following the receipt of a valid Execute Drive Diagnostics command, drive 1 shall negate -PDIAG within 1 msec to indicate to drive 0 that it is busy and has not yet passed its drive diagnostics. If drive 1 is present then drive 0 shall wait for up to 5 seconds from the receipt of a valid Execute Drive Diagnostics command for drive 1 to assert -PDIAG. Drive 1 should clear BSY before asserting -PDIAG, as -PDIAG is used to indicate that drive 1 has passed its diagnostics and is ready to post status.

If -DASP was not asserted by drive 1 during reset initialization, drive 0 shall post its own status immediately after it completes diagnostics, and clear the drive 1 Status register to 00h. Drive 0 may be unable to accept commands until it has finished its reset procedure and is ready (DRDY=1).

#### **KEY**

Pin position 20 has no connection pin. It is recommended to key or blank the respective position of the cable connector in order to avoid wrong insertion by mistake.

#### **5V Power**

There are two input pins for +5V power supply, "+5V LOGIC" and "+5V MOTOR". "+5V LOGIC" is connected to the internal logic circuits and "+5V MOTOR" is connected to the spindle motor and motor driver.

It is possible to turn on and off "+5V LOGIC" by an external switch circuit to reduce power consumption to the least possible. In this mode, a voltage drop out due to the motor spin up current can be reduced by connecting "+5V MOTOR" line into the system power source directly.

If the above power management is used, all signal lines that will be electrically active in the host system while the drive is disconnected from power line shall be isolated by Three-State line drivers. Internal leakage through ESD protection circuit may pull down LPUL (Least Positive Up Level) of logic signal below the spec.

Use both lines in parallel, for regular drive applications.

#### **-DMACK**

This signal shall be used by the host in response to DMARQ to either acknowledge that data has been accepted, or that data is available.

#### **DMARQ**

This signal, used for DMA data transfers between host and drive, shall be asserted by the drive when it is ready to transfer data to or from the host. The direction of data transfer is controlled by -HIOR and -HIOW. This signal is used on a handshake manner with -DMACK. This signal is a 3-state line with 24mA sink capability and internally pulled-down to GND through 10KOhm resistor.

## 6.5 Interface Logic Signal Levels

The interface logic signal have the following electrical specifications:

Inputs :	Input High Voltage	—	2.0 V min./ V <sub>CC</sub> +0.7 V max.
	Input Low Voltage	—	-0.5 V min./ 0.8 V max.
Outputs :	Output High Voltage	—	2.4 V min.
	Output Low Voltage	—	0.5 V max.
Current :	Driver Sink Current	—	24 mA min.
	Driver Source Current	—	-400 $\mu$ A min.

## 6.6 Signal Timings

### 6.6.1 Reset Timings

Reset timings of the drive are shown below.

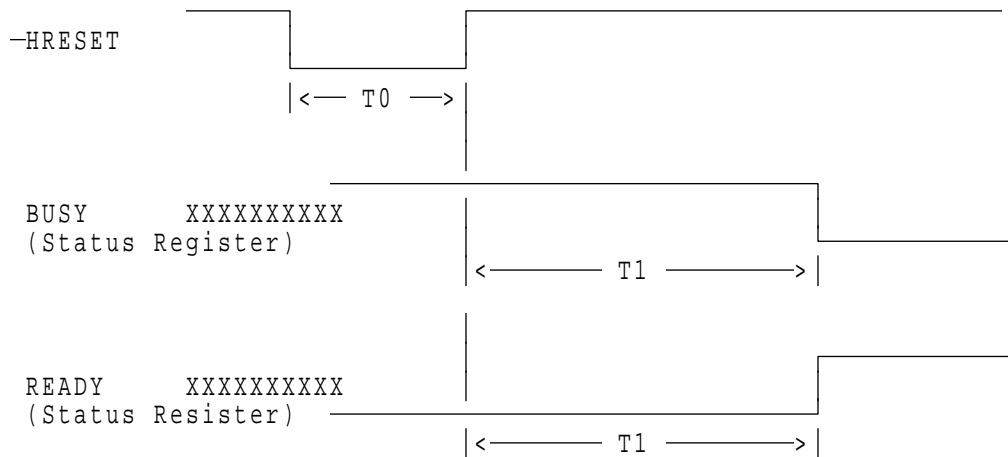

	PARAMETER DESCRIPTION	Min (usec)	Typ (sec)	Max (sec)
T0	-HRESET low width	25	—	—
T1	-HRESET high to READY/Not BUSY	—	2.3	9.5

Figure 23. System Reset timings

## 6.6.2 PIO Timings

The PIO cycle timings meet Mode 4 of the ATA-2 description.

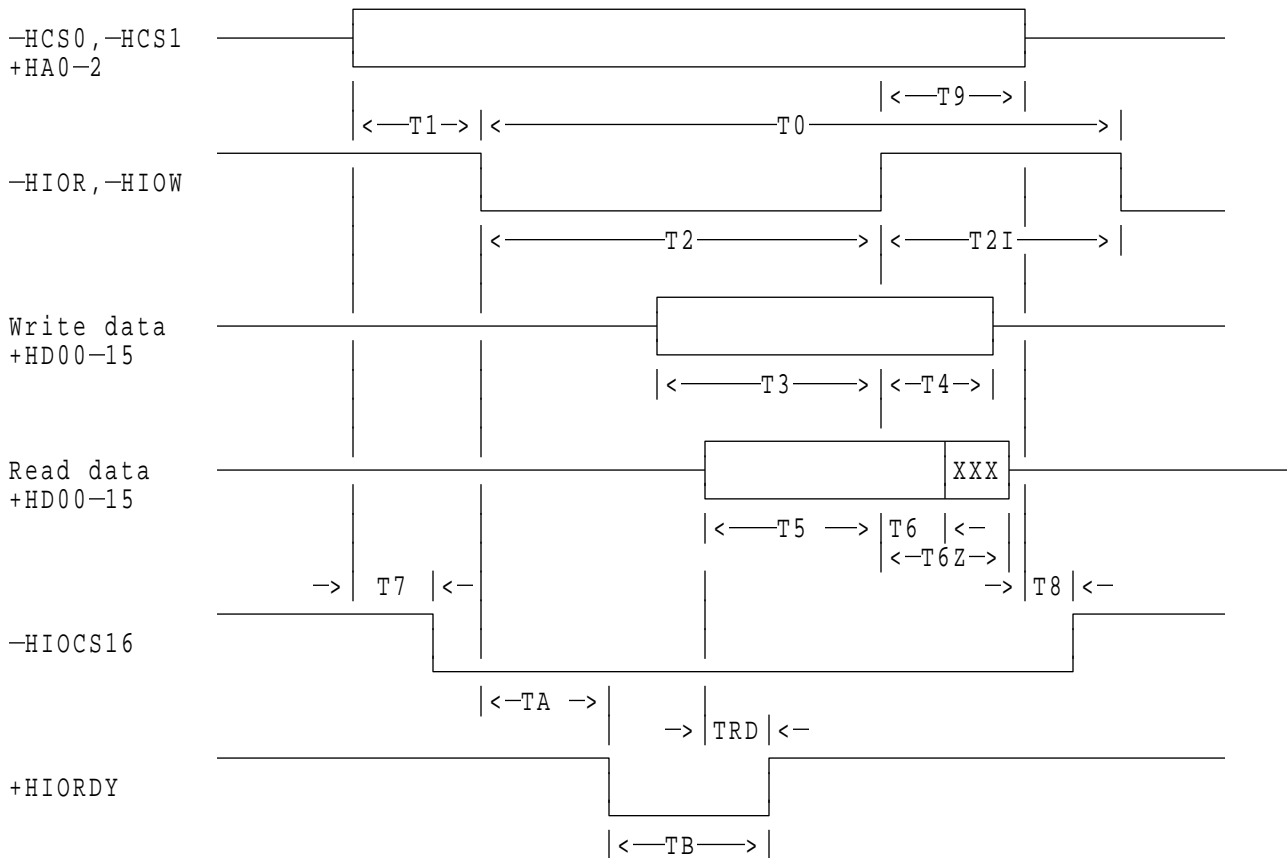

	PARAMETER DESCRIPTION	MIN (nsec)	MAX (nsec)	Note
T0	Cycle time	120	—	
T1	$\overline{\text{HCS0-1}}, \text{+HA00-02}$ valid to $\overline{\text{HIOR}}, \overline{\text{HIOW}}$ active	25	—	
T2	$\overline{\text{HIOR}}, \overline{\text{HIOW}}$ pulse width	70	—	
T2I	$\overline{\text{HIOR}}, \overline{\text{HIOW}}$ recovery	25	—	
T3	$\text{+HD00-15}$ setup to $\overline{\text{HIOW}}$ high	20	—	
T4	$\overline{\text{HIOW}}$ high to $\text{+HD00-15}$ hold	10	—	
T5	$\text{+HD00-15}$ setup to $\overline{\text{HIOR}}$ high	20	—	*1
T6	$\overline{\text{HIOR}}$ high to $\text{+HD00-15}$ hold	5	—	
T6Z	$\overline{\text{HIOR}}$ high to $\text{+HD00-15}$ tristate	—	30	
T7	$\overline{\text{HCS0-1}}, \text{+HA00-02}$ valid to $\overline{\text{HIOCS16}}$ assertion	—	30	
T8	$\overline{\text{HCS0-1}}, \text{+HA00-02}$ invalid to $\overline{\text{HIOCS16}}$ negation	—	30	
T9	$\overline{\text{HIOR}}, \overline{\text{HIOW}}$ high to $\overline{\text{HCS0-1}}, \text{+HA00-02}$ hold	10	—	
TRD	Read data valid to $\text{+HIORDY}$ active	0	—	
TA	$\overline{\text{HIOR}}, \overline{\text{HIOW}}$ low to $\text{+HIORDY}$ low	—	35	
TB	$\text{+HIORDY}$ pulse width	—	1250	

Note \*1 : This value is applied only when  $\text{+HIORDY}$  is not negated. When  $\text{+HIORDY}$  is negated, TRD is applied.

Figure 24. PIO cycle timings

### 6.6.3 DMA Timings (Single Word)

The Single Word DMA timing meets Mode 2 of the ATA-2 description.

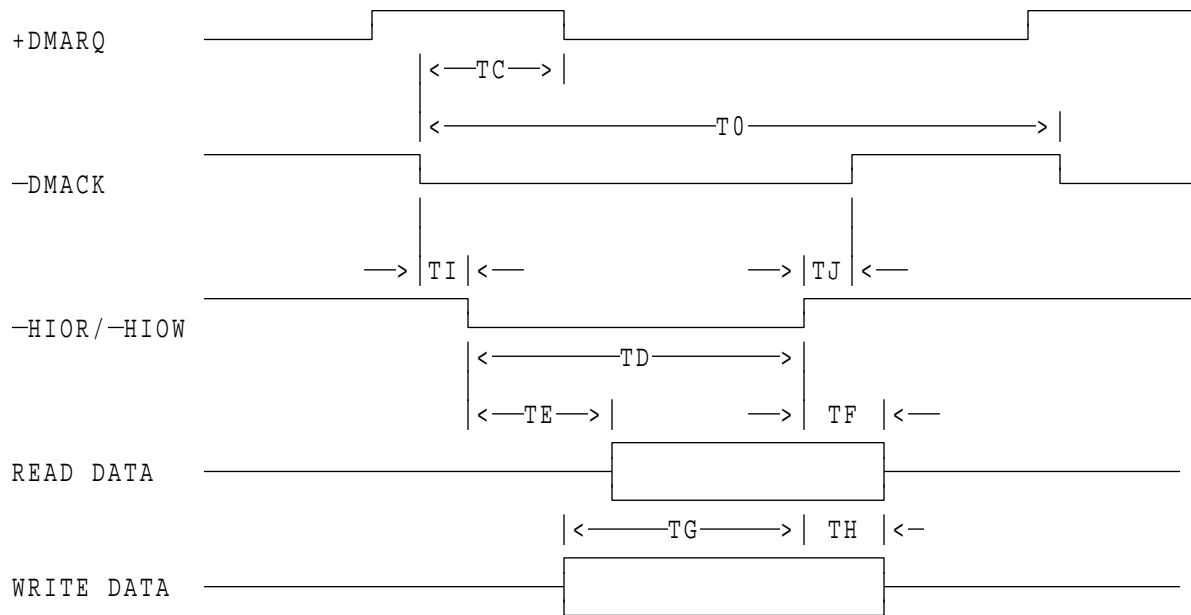

	PARAMETER DESCRIPTION	MIN (nsec)	MAX (nsec)	Note
T0	Cycle time	240	—	
TC	-DMA active to +DMARQ inactive	—	80	
TD	-HIOR, -HIOW pulse width	120	—	
TE	-HIOR data access	—	60	
TF	-HIOR data hold	5	—	
TG	-HIOW data setup	35	—	
TH	-HIOW data hold	20	—	
TI	-DMACK to -HIOR/-HIOW setup	0	—	
TJ	-HIOR/-HIOW to -DMACK hold	0	—	

Figure 25. DMA (Single Word) cycle timings

## 6.6.4 DMA Timings (Multiword)

- DMCA-2xxxx has two versions on Multiword DMA.
  - Multiword DMA Mode 2 support version. (minimum cycle time 120ns)
  - Multiword DMA Mode 1 support version. (minimum cycle time 240ns)

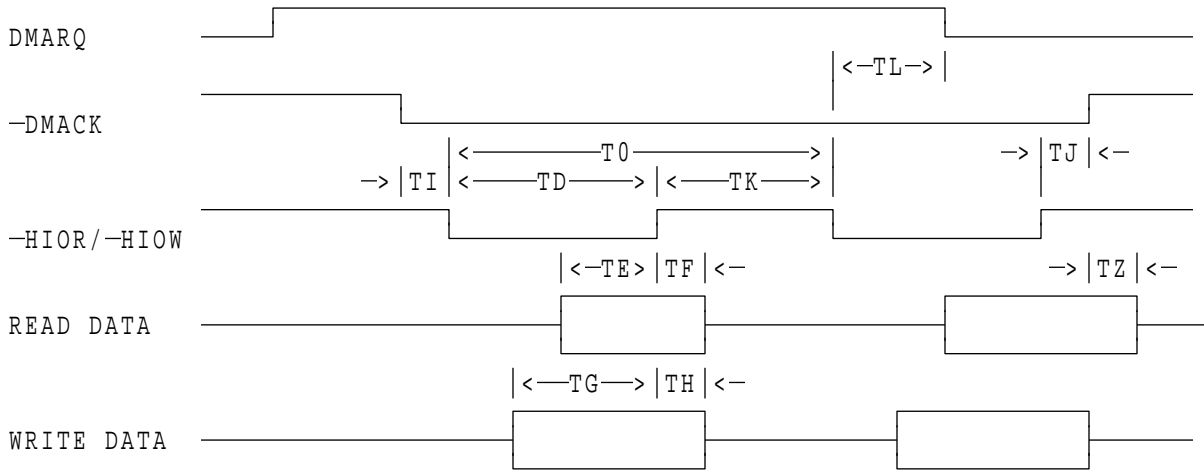

	PARAMETER DESCRIPTION	MIN (nsec)	MAX (nsec)	
T0	Cycle time	120 / 240	—	Note
TD	-HIOR,-HIOW pulse width	70	—	
TE	-HIOR data setup	20	—	
TF	-HIOR data hold	5	—	
TG	-HIOW data setup	20	—	
TH	-HIOW data hold	10	—	
TI	-DMACK to -HIOR/-HIOW setup	0	—	
TJ	-HIOR/-HIOW to -DMACK hold	5	—	
TK	-HIOR/-HIOW negated pulse width	25	—	
TL	-HIOR/-HIOW to -DMARQ delay	—	35	
TZ	-DMACK to tristate	—	25	

Figure 26. DMA (Multiword) cycle timings

- Note:** The cycle time is specified in word 65 of Identify Device data. See 12.5, “Identify Device (ECh)” on page 89 for details.

## 6.7 Drive Address Setting

A jumper is available at the interface connector to determine the drive address. The set position of the jumper is as shown in Figure 27.

Using Cable Selection, the drive address depends on the condition of pin 28 of the AT interface cable. In the case when pin 28 is ground or low, the drive is a Master. If pin 28 is open or high level, the drive is a Slave.

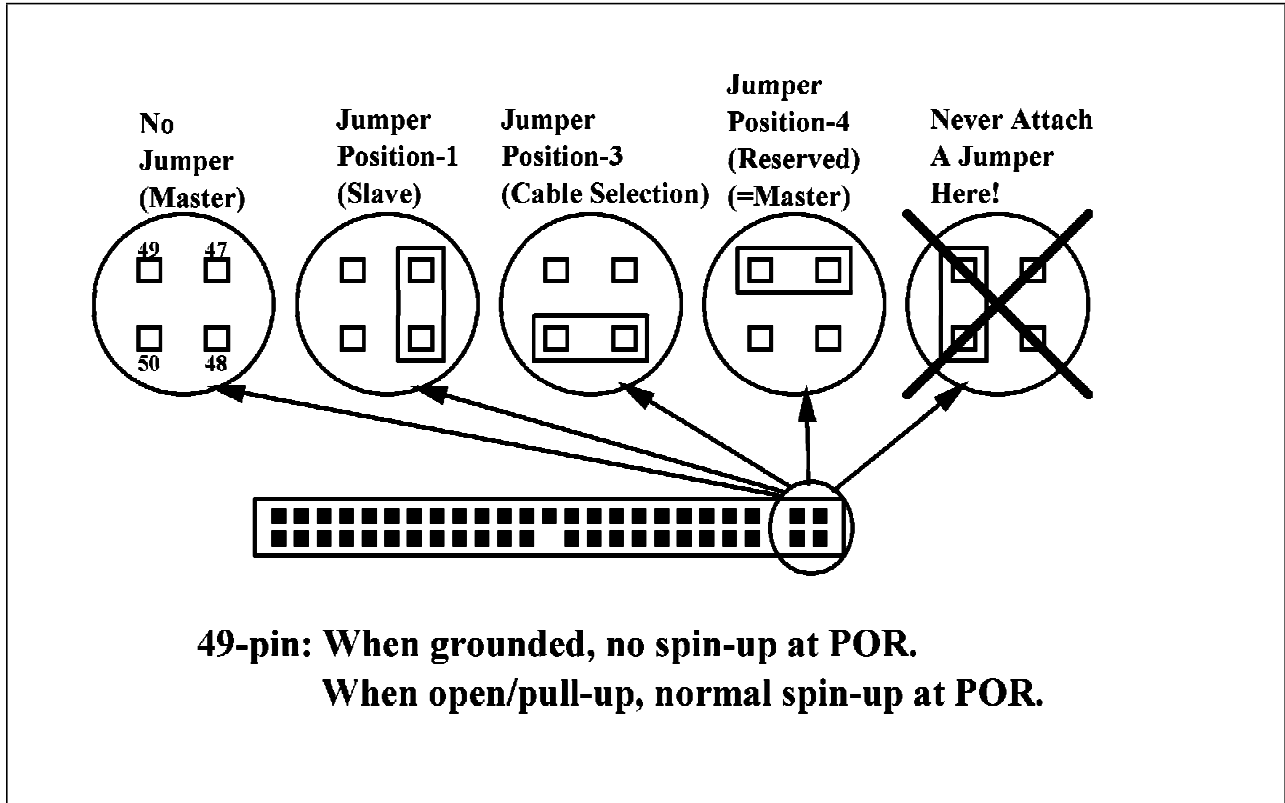

Figure 27. Address setting by a jumper for DMCA-21080/21440.

### 6.7.1 Default Setting

The default setting of jumper at shipment is No Jumper (Master).

## 6.8 Addressing of drive Registers

The host addresses the drive through a set of registers called a Task File. These registers are mapped into the host's I/O space. Two chip select lines (-HCS0 and -HCS1) and three address lines (HA00-02) are used to select one of these registers, while a -HIOR or -HIOW is provided at the specified time.

The -HCS0 is used to address Command Block registers, while the -HCS1 is used to address Control Block registers.

The following table shows the standard I/O address range for IBM PC-AT machines.

Addr.	-CS0	-CS1	HA2	HA1	HA0	-HIOR = 0 (Read)	-HIOW = 0 (Write)
Command Block Registers							
1F0	0	1	0	0	0	Data Reg.	Data Reg.
1F1	0	1	0	0	1	Error Reg.	Features Reg.
1F2	0	1	0	1	0	Sector count Reg.	Sector count Reg.
1F3	0	1	0	1	1	Sector number Reg.	Sector number Reg.
1F4	0	1	1	0	0	Cylinder low Reg.	Cylinder low Reg.
1F5	0	1	1	0	1	Cylinder high Reg.	Cylinder high Reg.
1F6	0	1	1	1	0	Drive/Head Reg.	Drive/Head Reg.
1F7	0	1	1	1	1	Status Reg.	Command Reg.
Control Block Registers							
3F6	1	0	1	1	0	Alt. Status Reg.	Device control Reg
3F7	1	0	1	1	1	Drive address Reg.	-

Figure 28. Register Address

**Note:** "Addr." field is shown just as an example.

---

## Part 2. ATA Interface Specification



---

## 7.0 General

---

### 7.1 Introduction

This specification describes the host interface to DMCA-2xxxx.

The interface conforms to the Working Document of Information technology - AT Attachment-3 Interface (ATA-3) Revision 6 dated on October 26, 1995. with certain limitations described in 8.0, “ Deviations From Standard” on page 45.

DMCA-2xxxx support following new functions included by ATA-3 standard.

- Security Mode Feature Set
- S.M.A.R.T.(Self-Monitoring, Analysis, and Reporting Technology) Function

DMCA-2xxxx support following functions as Vendor Specific Function.

- Format Unit Function
- Protected Area Function

---

### 7.2 Terminology

<b>Device</b>	Device indicates DMCA-2xxxx.
<b>Host</b>	Host indicates the system that the device is attached to.
<b>First Command</b>	The command which is executed first right after power on reset or hard reset when the initial power mode at power on is Standby mode.



---

## 8.0 Deviations From Standard

<b>BBK(Bad Block)</b>	Bit7 of Error Register is supported as BAD BLOCK bit. This bit will be set when BAD BLOCK is reported on Read commands.
<b>Check Power Mode</b>	CHECK POWER MODE command returns FFh to Sector Count Register when the device is in Idle mode. This command does not support 80h as the return value.
<b>Write Verify</b>	WRITE VERIFY command does not include read verification after write operation. The function is exactly same as WRITE SECTORS command.
<b>Standby Timer</b>	Even if IDLE command or STANDBY command is issued with Sector Cuont register value 00h, Standby Timer is not disabled, but it sets default value 109 minutes. In case Sector Count register value is other than 00h, Standby Timer is set to (Sector Count register value) x 5 seconds.



## 9.0 Registers

Addresses					Functions	
CS0-	CS1-	DA2	DA1	DA0	READ(DIOR-)	WRITE(DIOW-)
N	N	x	x	x	Data bus high imped*1	Not used
					Control block registers	
N	A	0	x	x	Data bus high imped	Not used
N	A	1	0	x	Data bus high imped	Not used
N	A	1	1	0	Alternate Status	Device Control
N	A	1	1	1	Device Address	Not used
					Command block registers	
A	N	0	0	0	Data	Data
A	N	0	0	1	Error Register	Features
A	N	0	1	0	Sector Count	Sector Count
A	N	0	1	1	Sector Number	Sector Number
A	N	0	1	1	*2 LBA bits 0-7	*2 LBA bits 0-7
A	N	1	0	0	Cylinder Low	Cylinder Low
A	N	1	0	0	*2 LBA bits 8-15	*2 LBA bits 8-15
A	N	1	0	1	Cylinder High	Cylinder High
A	N	1	0	1	*2 LBA bits 16-23	*2 LBA bits 16-23
A	N	1	1	0	Device/Head	Device/Head
A	N	1	1	0	*2 LBA bits 24-27	*2 LBA bits 24-27
A	N	1	1	1	Status	Command
A	A	x	x	x	Invalid address	Invalid address

\*1 "imped" stands for "impedance".  
 \*2 Mapping of registers in LBA mode

Logic conventions : A = signal asserted  
 N = signal negated  
 x = does not matter which it is

Figure 29. Register Set

Communication to or from the device is through an I/O Register that routes the input or output data to or from registers addressed by the signals from the host (CS0-, CS1-, DA2, DA1, DA0, DIOR- and DIOW-).

The Command Block Registers are used for sending commands to the device or posting status from the device.

The Control Block Registers are used for device control and to post alternate status.

### 9.1 Alternate Status Register

Alternate Status Register							
7	6	5	4	3	2	1	0
BSY	RDY	DF	DSC	DRQ	COR	IDX	ERR

Figure 30. Alternate Status Register

This register contains the same information as the Status Register. The only difference is that reading this register does not imply interrupt acknowledge or clear a pending interrupt. See 9.13, “ Status Register” on page 51 for the definition of the bits in this register.

## 9.2 Command Register

This register contains the command code being sent to the device. Command execution begins immediately after this register is written. The command set is shown in Figure 46 on page 79.

All other registers required for the command must be set up before writing the Command Register.

## 9.3 Cylinder High Register

This register contains the high order bits of the starting cylinder address for any disk access. At the end of the command, this register is updated to reflect the current cylinder number.

In LBA Mode this register contains Bits 16-23. At the end of the command, this register is updated to reflect the current LBA Bits 16-23.

The cylinder number may be from zero to the number of cylinders minus one.

## 9.4 Cylinder Low Register

This register contains the low order 8 bits of the starting cylinder address for any disk access. At the end of the command, this register is updated to reflect the current cylinder number.

In LBA Mode this register contains Bits 8-15. At the end of the command, this register is updated to reflect the current LBA Bits 8-15.

The cylinder number may be from zero to the number of cylinders minus one.

## 9.5 Data Register

This register is used to transfer data blocks between the device data buffer and the host. It is also the register through which sector information is transferred on a Format Track command, and configuration information is transferred on an Identify Device command.

All data transfers are 16 bits wide, except for ECC byte transfers, which are 8 bits wide. Data transfers are PIO only.

The register contains valid data only when DRQ=1 in the Status Register.

---

## 9.6 Device Control Register

Device Control Register							
7	6	5	4	3	2	1	0
—	—	—	—	1	SRST	—IEN	0

Figure 31. Device Control Register

### Bit Definitions

**SRST (RST)** Software Reset. The device is held reset when RST=1. Setting RST=0 re-enables the device.

The host must set RST=1 and wait for at least 5 microseconds before setting RST=0, to ensure that the device recognizes the reset.

**—IEN** Interrupt Enable. When IEN=0, and the device is selected, device interrupts to the host will be enabled. When IEN=1, or the device is not selected, device interrupts to the host will be disabled.

---

## 9.7 Drive Address Register

Drive Address Register							
7	6	5	4	3	2	1	0
HIZ	—WTG	—H3	—H2	—H1	—H0	—DS1	—DS0

Figure 32. Drive Address Register

This register contains the inverted drive select and head select addresses of the currently selected drive.

### Bit Definitions

**HIZ** High Impedance. This bit is not device and will always be in a high impedance state.

**—WTG** —Write Gate. This bit is 0 when writing to the disk device is in progress.

**—H3,—H2,—H1,—H0** —Head Select. These four bits are the one's complement of the binary coded address of the currently selected head. —H0 is the least significant.

**—DS1** —Drive Select 1. Drive select bit for device 1, active low. DS1=0 when device 1 (slave) is selected and active.

**—DS0** —Drive Select 0. Drive select bit for device 0, active low. DS0=0 when device 0 (master) is selected and active.

---

## 9.8 Device/Head Register

Device/Head Register							
7	6	5	4	3	2	1	0
1	L	1	DRV	HS3	HS2	HS1	HS0

Figure 33. Device/Head Register

This register contains the device and head numbers.

#### Bit Definitions

- L** Binary encoded address mode select. When L=0, addressing is by CHS mode. When L=1, addressing is by LBA mode.
- DRV** Device. When DRV=0, device 0 (master) is selected. When DRV=1, device 1 (slave) is selected.
- HS3,HS2,HS1,HS0** Head Select. These four bits indicate binary encoded address of the head. HS0 is the least significant bit. At command completion, these bits are updated to reflect the currently selected head.
- The head number may be from zero to the number of heads minus one.
- In LBA mode, HS3 through HS0 contain bits 24-27 of the LBA. At command completion, these bits are updated to reflect the current LBA bits 24-27.

---

## 9.9 Error Register

Error Register							
7	6	5	4	3	2	1	0
BBK	UNC	0	IDNF	0	ABRT	TK0NF	AMNF

Figure 34. Error Register

This register contains status from the last command executed by the device, or a diagnostic code.

At the completion of any command except Execute Device Diagnostic, the contents of this register are valid always even if ERR=0 in the Status Register.

Following a power on, a reset, or completion of an Execute Device Diagnostic command, this register contains a diagnostic code. See Figure 38 on page 55 for the definition.

#### Bit Definitions

- BBK** Bad Block. BBK=1 indicates a bad block mark was detected in the requested sector's ID field.
- UNC** Uncorrectable Data Error. UNC=1 indicates an uncorrectable data error has been encountered.
- IDNF (IDN)** ID Not Found. IDN=1 indicates the requested sector's ID field could not be found.
- ABRT (ABT)** Aborted Command. ABT=1 indicates the requested command has been aborted due to a device status error or an invalid parameter in an output register.

<b>TK0NF (T0N)</b>	Track 0 Not Found. T0N=1 indicates track 0 was not found during a Recalibrate command.
<b>AMNF (AMN)</b>	Address Mark Not Found. AMN=1 indicates the data address mark has not been found after finding the correct ID field for the requested sector.

---

## 9.10 Features Register

This register is command specific. This is used with the Set Features command.

---

## 9.11 Sector Count Register

This register contains the number of sectors of data requested to be transferred on a read or write operation between the host and the device. If the value in the register is set to 0, a count of 256 sectors is specified.

If the register is zero at command completion, the command was successful. If not successfully completed, the register contains the number of sectors which need to be transferred in order to complete the request.

The contents of the register are defined otherwise on some commands. These definitions are given in the command descriptions.

---

## 9.12 Sector Number Register

This register contains the starting sector number for any disk data access for the subsequent command. The sector number is from one to the maximum number of sectors per track.

In LBA mode, this register contains Bits 0-7. At the end of the command, this register is updated to reflect the current LBA Bits 0-7.

---

## 9.13 Status Register

Status Register							
7	6	5	4	3	2	1	0
BSY	DRDY	DF	DSC	DRQ	CORR	IDX	ERR

Figure 35. Status Register

This register contains the device status. The contents of this register are updated whenever an error occurs and at the completion of each command.

If the host reads this register when an interrupt is pending, it is considered to be the interrupt acknowledge. Any pending interrupt is cleared whenever this register is read.

If BSY=1, no other bits in the register are valid.

## Bit Definitions

<b>BSY</b>	Busy. BSY=1 whenever the device is accessing the registers. The host should not read or write any registers when BSY=1. If the host reads any register when BSY=1, the contents of the Status Register will be returned.
<b>DRDY (RDY)</b>	Device Ready. RDY=1 indicates that the device is capable of responding to a command. RDY will be set to 0 during power on until the device is ready to accept a command. If the device detects an error while processing a command, RDY is set to 0 until the Status Register is read by the host, at which time RDY is set back to 1.
<b>DF</b>	Device Fault. DF=1 indicates that the device has detected a write fault condition. DF is set to 0 after the Status Register is read by the host.
<b>DSC</b>	Device Seek Complete. DSC=1 indicates that a seek has completed and the device head is settled over a track. DSC is set to 0 by the device just before a seek begins. When an error occurs, this bit is not changed until the Status Register is read by the host, at which time the bit again indicates the current seek complete status.  When the device enters into or is in Standby mode or Sleep mode, this bit is set by device in spite of not spinning up.
<b>DRQ</b>	Data Request. DRQ=1 indicates that the device is ready to transfer a word or byte of data between the host and the device. The host should not write the Command register when DRQ=1.
<b>CORR (COR)</b>	Corrected Data. Always 0.
<b>IDX</b>	Index. IDX=1 once per revolution. Since IDX=1 only for a very short time during each revolution, the host may not see it set to 1 even if the host is reading the Status Register continuously. Therefore the host should not attempt to use IDX for timing purposes.
<b>ERR</b>	Error. ERR=1 indicates that an error occurred during execution of the previous command. The Error Register should be read to determine the error type. The device sets ERR=0 when the next command is received from the host.

## 10.0 General Operation Descriptions

### 10.1 Reset Response

There are three types of reset in ATA as follows:

#### Power On Reset (POR)

The device executes a series of electrical circuitry diagnostics, spins up the HDA, tests speed and other mechanical parametrics, and sets default values.

#### Hard Reset (Hardware Reset)

RESET- signal is negated in ATA Bus.

The device executes a series of electrical circuitry diagnostics, spins up the HDA, tests speed and other mechanical parametrics, and sets default values.

#### Soft Reset (Software Reset)

SRST bit in the Device Control Register is set, then is reset.

The device resets the interface circuitry according to the Set Features requirement.

The actions of each reset is shown in Figure 36

	POR	hard reset	soft reset
Aborting Host interface	—	0	0
Aborting Device operation	—	(*1)	(*1)
Initialization of hardware	0	0	x
Internal diagnostic	0	0	x
Spinning spindle	(*6)	(*6)	x
Initialization of registers (*2)	0	0	0
DASP handshake	0	0	x
PDIAG handshake	0	0	0
Reverting programmed parameters to default	0	0	(*3)
— Number of CHS (set by Initialize Device Parameter)			
— Multiple mode			
— Write cache			
— Read look-ahead			
— ECC bytes			
Disable Standby timer	0	0	x
Power mode	(*6)	(*6)	(*4)
Reset Standby timer value (*5)	0	0	x

0 — execute  
x — not execute

Figure 36. Reset Response Table

Note.

(\*1) Execute after the data in write cache has been written.

- (\*2) Default value on POR is shown in Figure 37 on page 55.
- (\*3) The Set Features command with Feature register = CCh enables the device to revert these parameters to the power on defaults.
- (\*4) In the case of sleep mode, the device goes to idle mode. In other case, the device does not change current mode.
- (\*5) After reset the Standby timer value, it is set to 109 minutes.
- (\*6) According to the initial power mode selection.

## 10.1.1 Register Initialization

Register	Default Value
Error	Diagnostic Code
Sector Count	01h
Sector Number	01h
Cylinder Low	00h
Cylinder High	00h
Device/Head	A0h
Status	50h
Alternate Status	50h

Figure 37. Default Register Values

After power on, hard reset, or software reset, the register values are initialized as shown in Figure 37.

Code	Description
01h	No error detected
02h	Formatter device error
03h	Sector buffer error
04h	ECC circuitry error
05h	Controller microprocessor error
8xh	Device 1 failed

Figure 38. Diagnostic Codes

The meaning of the Error Register diagnostic codes resulting from power on, hard reset or the Execute Device Diagnostic command are shown in Figure 38.

## 10.2 Diagnostic and Reset considerations

For each Reset and Execute Device Diagnostic, the diagnostic is done as follows:

### Power On Reset

DASP- is read by Device 0 to determine if Device 1 is present. If Device 1 is present Device 0 shall read PDIAG- to determine when it is valid to clear the BSY bit and whether Device 1 has powered on or reset without error, otherwise Device 0 clears the BSY bit whenever it is ready to accept commands. Device 0 may assert DASP- to indicate device activity. If Device 1 is not present, Device 0 does not Assert DASP- at POR.

### Soft Reset, Hard Reset

If Device 1 is present Device 0 shall read PDIAG- to determine when it is valid to clear the BSY bit and whether Device 1 has reset without any errors, otherwise Device 0 shall simply reset and clear the BSY bit. DASP- is asserted by Device 0 (and Device 1 if it is present) in order to indicate device active.

### Execute Device Diagnostic

If Device 1 is present, Device 0 shall read PDIAG- to determine when it is valid to clear the BSY bit and if Device 1 passed or failed the EXECUTE DEVICE DIAGNOSTIC command, otherwise Device 0 shall simply execute its diagnostics and then clear the BSY bit. DASP- is asserted by Device 0 (and Device 1 if it is present) in order to indicate the device is active.

In all the above cases: Power on, RESET-, Soft reset, and the EXECUTE DEVICE DIAGNOSTIC command the Device 0 Error register is shown in Figure 39.

Device 1 Present?	PDIAG- Asserted?	Device 0 Passed	Error Register
Yes	Yes	Yes	01h
Yes	Yes	No	0xh
Yes	No	Yes	81h
Yes	No	No	8xh
No	(not read)	Yes	01h
No	(not read)	No	0xh

Where x indicates the appropriate Diagnostic Code for the Power on, RESET-, Soft reset, or Device Diagnostic error.

Figure 39. Reset error register values

---

## 10.3 Sector Addressing Mode

All addressing of data sectors recorded on the device's media is by a logical sector address. The logical CHS address for &Crescendo./DMCA-2xxxx is different from the actual physical CHS location of the data sector on the disk media.

&Crescendo./DMCA-2xxxx support both Logical CHS Addressing Mode and LBA Addressing Mode as the sector addressing mode.

The host system may select either the currently selected CHS translation addressing or LBA addressing on a command-by-command basis by using the L bit in the DEVICE/HEAD register. So a host system must set the L bit to 1 if the host uses LBA Addressing mode.

### 10.3.1 Logical CHS Addressing Mode

The logical CHS addressing is made up of three fields: the cylinder number, the head number and the sector number. Sectors are numbered from 1 to the maximum value allowed by the current CHS translation mode but can not exceed 255(0FFh). Heads are numbered from 0 to the maximum value allowed by the current CHS translation mode but can not exceed 15(0Fh). Cylinders are numbered from 0 to the maximum value allowed by the current CHS translation mode but cannot exceed 65535(0FFFFh).

When the host selects a CHS translation mode using the INITIALIZE DEVICE PARAMETERS command, the host requests the number of sectors per logical track and the number of heads per logical cylinder. The device then computes the number of logical cylinders available in requested mode.

The default CHS translation mode is described in the Identify Device Information. The current CHS translation mode also is described in the Identify Device Information.

### 10.3.2 LBA Addressing Mode

Logical sectors on the device shall be linearly mapped with the first LBA addressed sector (sector 0) being the same sector as the first logical CHS addressed sector ( cylinder 0, head 0, sector 1). Irrespective of the logical CHS translation mode currently in effect, the LBA address of a given logical sector does not change. The following is always true:

$$\text{LBA} = ( (\text{cylinder} * \text{heads\_per\_cylinder} + \text{heads}) * \text{sectors\_per\_track} ) + \text{sector} - 1$$

where heads\_per\_cylinder and sectors\_per\_track are the current translation mode values.

On LBA addressing mode, the LBA value is set to the following register.

Device/Head	<---	LBA bits 27-24
Cylinder High	<---	LBA bits 23-16
Cylinder Low	<---	LBA bits 15- 8
Sector Number	<---	LBA bits 7- 0

---

## 10.4 Power Management Feature

The power management feature set permits a host to modify the behavior of a manner which reduces the power required to operate. The power management feature set provides a set of commands and a timer that enable a device to implement low power consumption modes.

DMCA-2xxxx implement the following set of functions.

1. A Standby timer
2. Idle command
3. Idle Immediate command
4. Sleep command
5. Standby command
6. Standby Immediate command

### 10.4.1 Power Mode

The lowest power consumption when the device is powered on occurs in Sleep Mode. When in sleep mode, the device requires a reset to be activated. The time to respond could be as long as the power on reset time.

In Standby Mode the device interface is capable of accepting commands, but as the media may not immediately accessible, there is a delay while waiting for the spindle to reach operating speed.

In Idle Mode the device is capable of responding immediately to media access requests.

In Active Mode the device is under executing a command or accessing the disk media with read look-ahead function or write cache function.

### 10.4.2 Power Management Commands

The Check Power Mode command allows a host to determine if a device is currently in, going to or leaving standby mode.

The Idle and Idle Immediate commands move a device to idle mode immediately from the active or standby modes. The idle command also sets the standby timer count and starts the standby timer.

The sleep command moves a device to sleep mode. The device's interface becomes inactive at the completion of the sleep command. A reset is required to move a device out of sleep mode. When a device exits sleep mode it will enter idle mode.

The Standby and Standby Immediate commands move a device to standby mode immediately from the active or idle modes. The standby command also sets the standby timer count.

### 10.4.3 Standby/Sleep command completion timing

1. Confirm the completion of the cached write commands
2. Set INTRQ (completion of the command)
3. Move heads to park position
4. Activate the spindle brake to stop the spindle motor

5. Wait 1.5 Sec to spindle motor is stopped
6. Perform post process

#### 10.4.4 Standby timer

The standby timer provides a method for the device to automatically enter standby mode from either active or idle mode following a host programmed period of inactivity. If the device is in the active or idle mode, the device waits for the specified time period and if no command is received, the device automatically enters the standby mode.

If the value of SECTOR COUNT register on Idle command or Standby command is set to 00h, the device will automatically set the standby timer to 109 minutes.

#### 10.4.5 Status

In the active, idle and standby modes, the device shall have RDY bit of the status register set. If BSY bit is not set, shall be ready to accept any command.

In sleep mode, the device's interface is not active. A host shall not attempt to read the device's status or issue commands to the device.

#### 10.4.6 Interface Capability for Power Modes

The each power mode affects the physical interface as defined in the following table:

Mode	BSY	RDY	Interface active	Media
Active	x	x	Yes	Active
Idle	o	1	Yes	Active
Standby	o	1	Yes	Inactive
Sleep	x	x	No	Inactive

Figure 40. Power conditions

Ready(RDY) is not a power condition. A device may post ready at the interface even though the media may not be accessible.

Though the interface is inactive in sleep mode, the access to the interface registers and the validity of INTRQ is guaranteed for two seconds after Sleep command is completed. After this period, the contents of interface registers may be lost. Since the contents of interface registers may be invalid, host should NOT check Status register nor Alternate Status register prior to issuing soft reset to wake up a device.

#### 10.4.7 Initial Power Mode at Power On

After power on or hard reset the device goes to IDLE mode or STNADBY mode depending on the option. Refer &FFS. for the intial power mode selection.

---

## 10.5 Adaptive Power Management Feature

This feature is developed to improve the power consumption and performance in mobile hard drives. This power management technology intelligently manages power modes within the device by adapting to the individual users recent disk access pattern. DMCA-2xxxx support this feature.

This feature has two-stage idle mode. One is Performance Idle mode. Another is Low Power (LP) Idle mode.

### 10.5.1 Performance Idle mode

This mode is usually entered immediately after Active mode command processing is complete, instead of conventional idle mode. In Performance Idle mode, all electronic components remain powered and full frequency servo remains operational. This provides instantaneous response to the next command. The duration of this mode is intelligently managed as described below.

### 10.5.2 Low Power (LP) Idle mode

In this mode, power consumption is 15-20% less than conventional idle mode. Additional electronics are powered off, and the head is parked near the mid-diameter of the disk without servoing. Recovery time to Active mode is about 40ms.

### 10.5.3 Transition Time

The transition time is dynamically managed by users recent access pattern, instead of fixed times. The algorithm monitors the frequency of commands over intervals of interest, usually several seconds. The algorithm judges how long the current burst of commands will continue by maintaining a distribution of command frequencies. After each command, the algorithm calculates the probability that the current burst of commands is complete based on the statistics of the distribution.

Each time this algorithm decides that the current burst of commands is not yet complete, it places the device in Performance Idle mode. This means another command will arrive very soon, and the response to it can now be instantaneous without the delay associated with conventional idle. Since bursts usually contain tens of commands, performance is improved.

When this algorithm decides the current burst of commands is complete, it knows with high probability that the next command will not occur for a relatively long time (seconds). To conserve power, this feature places the device in LP Idle mode, then performs a seek to the mid-band and enters a low power state.

The optimal time to enter LP Idle is variable depending on the users recent behavior. It is not possible to achieve the same level of savings with a fixed entry time into LP Idle because every users data and access pattern is different. The optimum entry time changes over time.

To recover to Active mode from LP Idle requires about 40 ms. This does not represent a significant performance impact because it is a relatively rare event, and because a new burst of commands almost always begins with a seek to a new location which requires the time anyway. Throughput is maintained because LP Idle is entered only when a long idle interval is anticipated.

---

## 10.6 S.M.A.R.T. Function

The intent of Self-monitoring, analysis and reporting technology (S.M.A.R.T) is to protect user data and prevent unscheduled system downtime that may be caused by predictable degradation and/or fault of the device. By monitoring and storing critical performance and calibration parameters, S.M.A.R.T devices employ sophisticated data analysis algorithms to predict the likelihood of near-term degradation or fault condition. By alerting the host system of a negative reliability status condition, the host system can warn the user of the impending risk of a data loss and advise the user of appropriate action.

Since S.M.A.R.T. utilizes the internal device microprocessor and other device resources, there may be some small overhead associated with its operation. However, special care has been taken in the design of the S.M.A.R.T. algorithms to minimize the impact to host system performance. Actual impact of S.M.A.R.T. overhead is dependent on the specific device design and the usage patterns of the host system. To further ensure minimal impact to the user, S.M.A.R.T. capable devices are shipped from the device manufacturer's factory with the S.M.A.R.T. feature disabled. S.M.A.R.T. capable devices can be enabled by the system OEMs at time of system integration or in the field by aftermarket products.

### 10.6.1 Attributes

Attributes are the specific performance or calibration parameters that are used in analyzing the status of the device. Attributes are selected by the device manufacturer based on that attribute's ability to contribute to the prediction of degrading or faulty conditions for that particular device. The specific set of attributes being used and the identity of these attributes is vendor specific and proprietary.

### 10.6.2 Attribute values

Attribute values are used to represent the relative reliability of individual performance or calibration attributes. Higher attribute values indicate that the analysis algorithms being used by the device are predicting a lower probability of a degrading or fault condition existing. Accordingly, lower attribute values indicate that the analysis algorithms being used by the device are predicting a higher probability of a degrading or fault condition existing. There is no implied linear reliability relationship corresponding to the numerical relationship between different attribute values for any particular attribute.

### 10.6.3 Attribute thresholds

Each attribute value has a corresponding attribute threshold limit which is used for direct comparison to the attribute value to indicate the existence of a degrading or faulty condition. The numerical value of the attribute thresholds are determined by the device manufacturer through design and reliability testing and analysis. Each attribute threshold represents the lowest limit to which its corresponding attribute value can be equal while still retaining a positive reliability status. Attribute thresholds are set at the device manufacturer's factory and cannot be changed in the field. The valid range for attribute thresholds is from 1 through 253 decimal.

### 10.6.4 Threshold exceeded condition

If one or more attribute values are less than or equal to their corresponding attribute thresholds, then the device reliability status is negative, indicating an impending degrading or faulty condition.

### 10.6.5 S.M.A.R.T. commands

The S.M.A.R.T. commands provide access to attribute values, attribute thresholds and other logging and reporting information.

## **10.6.6 S.M.A.R.T. operation with power management modes**

It is recommended that, when a host system utilizes both the power management and S.M.A.R.T. features, the system enable the device's attribute autosave feature to allow the device's automatic attribute saving upon receipt of STANDBY IMMEDIATE or SLEEP commands. If the device has been set to utilize the standby timer, the device also saves attributes values prior to going from an Idle state to Standby state.

---

## 10.7 Security Mode Feature Set

Security Mode Feature Set is powerful security feature. With a device lock password, user can prevent unauthorized access to hard disk device even if the device is removed from the computer.

New commands are supported for this feature as below.

<b>Security Set Password</b>	('F1'h)
<b>Security Unlock</b>	('F2'h)
<b>Security Erase Prepare</b>	('F3'h)
<b>Security Erase Unit</b>	('F4'h)
<b>Security Freeze Lock</b>	('F5'h)
<b>Security Disable Password</b>	('F6'h)

### 10.7.1 Security mode

Following security modes are provided.

<b>Device Locked mode</b>	The device disables media access commands after power on. Media access commands are enabled by either a security unlock command or a security erase unit command.
<b>Device Unlocked mode</b>	The device enables all commands. If a password is not set this mode is entered after power on, otherwise it is entered by a security unlock or a security erase unit command.
<b>Device Frozen mode</b>	The device enables all commands except those which can update the device lock function, set/change password. The device enters this mode via a Security Freeze Lock command. It cannot quit this mode until power off.

### 10.7.2 Security level

Following security levels are provided.

<b>High level security</b>	When the device lock function is enabled and the User Password is forgotten the device can be unlocked via a Master Password.
<b>Maximum level security</b>	When the device lock function is enabled and the User Password is forgotten then only the Master Password with an Security Erase Unit command can unlock the device. Then user data is erased.

### 10.7.3 Password

This function can have 2 types of passwords as described below.

<b>Master Password</b>	When the Master Password is set, the device does NOT enable the Device Lock Function, and the device can NOT be locked with the Master Password, but the Master Password can be used for unlocking the device locked.
<b>User Password</b>	The User Password should be given or changed by a system user. When the User Password is set, the device enables the Device Lock Function. And then the device is locked on next power on reset or hard reset.

The system manufacturer/dealer who intend to enable the device lock function to the end users, must be set the master password even if only single level password protection is required. Otherwise, the 'default' master password which is set by IBM can unlock the device which is locked with user password.

## 10.7.4 Operation example

### 10.7.4.1 Master Password setting

The system manufacturer/dealer can set to a new Master Password from default Master Password using the Security Set Password command, without enabling the Device Lock Function.

### 10.7.4.2 User Password setting

When a User Password is set, the device will automatically enter lock mode the next time the device is powered on.

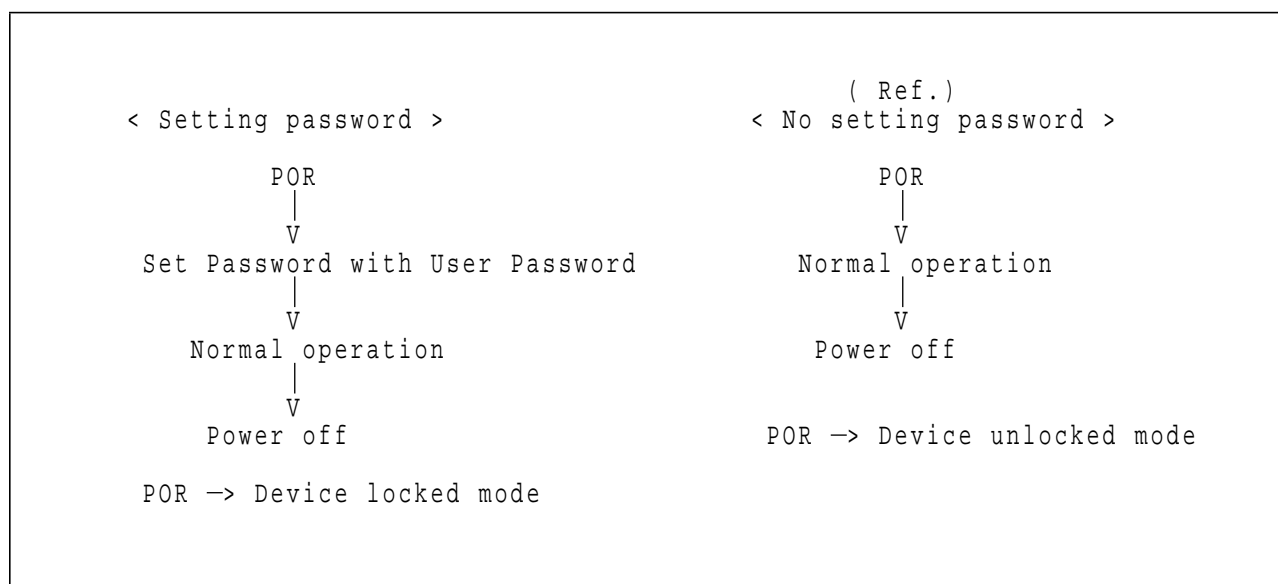

Figure 41. Initial Setting

### 10.7.4.3 Operation from POR after User Password is set

When Device Lock Function is enabled, the device rejects media access command until an Security Unlock command is successfully completed.

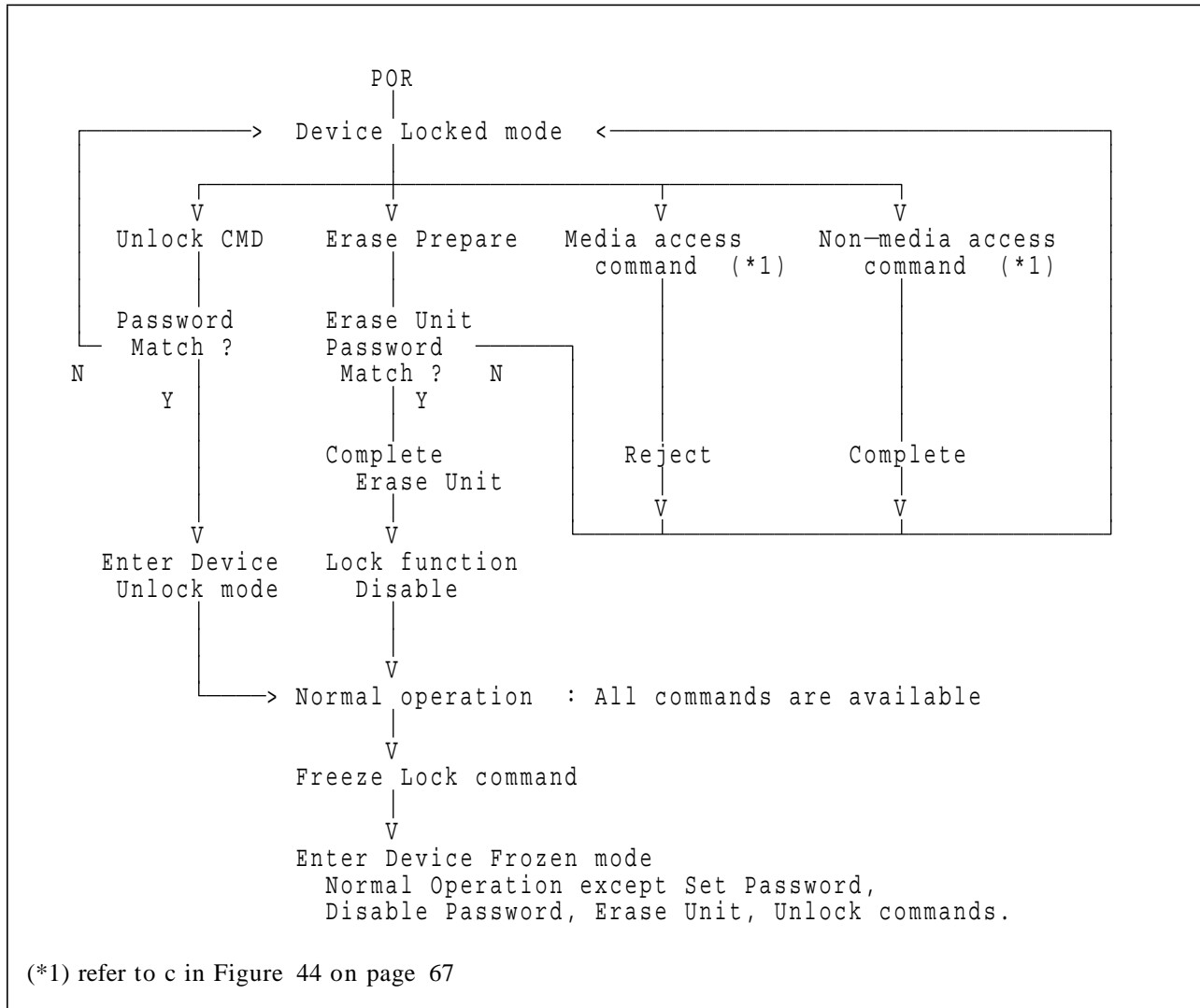

Figure 42. Usually Operation

#### 10.7.4.4 User Password Lost

If the User Password is forgotten and High level security is set, the system user can't access any data. However the device can be unlocked using the Master Password.

If a system user forgets the User Password and Maximum security level is set, data access is impossible. However the device can be unlocked using the Security Erase Unit command to unlock the device and erase all user data with the Master Password.

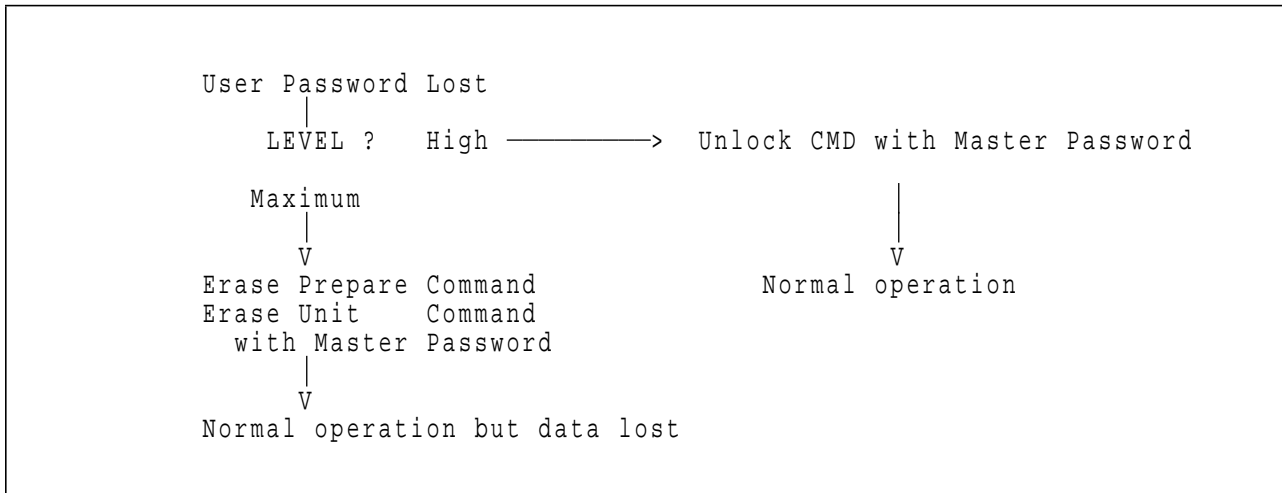

Figure 43. Password Lost

#### 10.7.4.5 Attempt limit for SECURITY UNLOCK command

The SECURITY UNLOCK command has an attempt limit. The purpose of this attempt limit is to prevent that someone attempts to unlock the drive by using various passwords many times.

The device counts the password mismatch. If the password does not match, the device counts it up without distinguishing the Master password and the User password. If the count reaches 5, EXPIRE bit(bit 4) of Word 128 in Identify Device information is set, and then SECURITY ERASE UNIT command and SECURITY UNLOCK command are aborted until a hard reset or a power off. The count and EXPIRE bit are cleared after a power on reset or a hard reset.

## 10.7.5 Command Table

This table shows the device's response to commands when the Security Mode Feature Set (Device lock function) is enabled.

Command	Device Locked Mode	Device Unlock Mode	Device Frozen Mode
Check Power Mode	0	0	0
Execute Device Diagnostic	0	0	0
Format Track	x	0	0
Format Unit	x	0	0
Identify Device	0	0	0
Identify Device DMA	0	0	0
Idle	0	0	0
Idle Immediate	0	0	0
Initialize Device Parameters	0	0	0
Read Buffer	0	0	0
Read DMA (w/o retry)	x	0	0
Read DMA (w/retry)	x	0	0
Read Long (w/o retry)	x	0	0
Read Long (w/retry)	x	0	0
Read Multiple	x	0	0
Read Native Max LBA/CYL	0	0	0
Read Sector(s) (w/o retry)	x	0	0
Read Sector(s) (w/retry)	x	0	0
Read Verify Sector(s) (w/o retry)	x	0	0
Read Verify Sector(s) (w/retry)	x	0	0
Recalibrate	0	0	0
Security Disable Password	x	0	x
Security Erase Prepare	0	0	0
Security Erase Unit	0	0	x
Security Freeze Lock	x	0	0
Security Set Password	x	0	x
Security Unlock	0	0	x
Seek	0	0	0
Set Features	0	0	0
Set Max LBA/CYL	0	0	0
Set Multiple Mode	0	0	0
Sleep	0	0	0

Figure 44. Command table for device lock operation

Command	Device Locked Mode	Device Unlock Mode	Device Frozen Mode
SMART Disable Operations	0	0	0
SMART Enable/Disable Attribute Autosave	0	0	0
SMART Enable Operations	0	0	0
SMART Execute Off-line Data Collection	0	0	0
SMART Read Attribute Values	0	0	0
SMART Read Attribute Thresholds	0	0	0
SMART Return Status	0	0	0
SMART Save Attribute Values	0	0	0
Standby	0	0	0
Standby Immediate	0	0	0
Write Buffer	0	0	0
Write DMA (w/o retry)	x	0	0
Write DMA (w/retry)	x	0	0
Write Long (w/o retry)	x	0	0
Write Long (w/retry)	x	0	0
Write Multiple	x	0	0
Write Sector(s) (w/o retry)	x	0	0
Write Sector(s) (w/retry)	x	0	0
Write Verify	x	0	0

- o — Device executes command normally  
x — Device terminates command with error register of Aborted Command.

Figure 45. Command table for device lock operation - continued

---

## 10.8 Protected Area Function (Vendor Specific)

Protected Area Function is to provide the 'protected area' which can not be accessed via conventional method. This 'protected area' is used to contain critical system data such as BIOS or system management information. The contents of entire system main memory may also be dumped into 'protected area' to resume after system power off.

The LBA/CYL changed by following command affects the Identify Device Information.

Two vendor specific commands are defined for this function.

**Read Native Max LBA/CYL** ('F8'h)

**Set Max LBA/CYL** ('F9'h)

### 10.8.1 Example for operation (In LBA mode)

Assumptions :

For better understanding, following example uses actual values for LBA, size, etc. Since it is just an example, those value could be different.

Device characteristics

Capacity (native)	: 536,870,912 byte (536MB)
Number of LBA (native)	: 1,048,576 (100000h)
Max LBA (native)	: 1,048,575 (0FFFFFh)
Required size for protected area	: 8,388,608 byte
Required blocks for protected area	: 16,384 (004000h)
Customer usable device size	: 528,482,304 byte (528MB)
Customer usable sector count	: 1,032,192 (0FC000h)
LBA range for protected area	: 0FC000h to 0FFFFFh

#### 1. Shipping HDDs from HDD manufacturer

When the HDDs are shipped from HDD manufacturer, the device has been tested to have capacity of 536MB, flagged the media defects not to be visible by system.

#### 2. Preparing HDDs at system manufacturer

Special utility software is required to define the size of protected area and store the data into it. The sequence is :

Issue Read Native Max LBA/CYL command to get the real device Number of LBA/CYL. Returned value shows that native device Number of LBA is 100000h regardless to the current setting.

Make entire device be accessible including the protected area by setting device Number of LBA as 100000h via Set Max LBA/CYL command. The option could be either nonvolatile or volatile.

Test the sectors for protected are (LBA > = 0FC000h) if required.

Write information data such as BIOS code within the protected area.

Change Number of LBA using Set Max LBA/CYL command to 0FC000h with nonvolatile option.

From this point, the protected area cannot be accessed till next Set Max LBA/CYL command is issued. Any BIOSes, device drivers, or application software access the HDD as if that is the 528MB device because the device acts exactly same as real 528MB device does.

### 3. Conventional usage without system software support

Since the HDD works as 528MB device, there are no special care to use this device for normal use.

### 4. Advanced usage using protected area

The data in protected area is accessed by following.

Issue Read Native Max LBA/CYL command to get the real device Number of LBA/CYL. Returned value shows that native device Number of LBA is 100000h regardless to the current setting.

Make entire device be accessible including the protected area by setting device Number of LBA as 100000h via Set Max LBA/CYL command with volatile option. By using this option, unexpected power removal or reset will not make the protected area remained accessible.

Read information data from protected area.

Issue hard reset or POR to inhibit any access to the protected area.

---

## 10.9 Write Cache Function

Write cache is a performance enhancement whereby the device reports as completing the write command (Write Sectors and Write Multiple) to the host as soon as the device has received all of the data into its buffer. And the device assumes responsibility to write the data subsequently onto the disk.

- While writing data after completed acknowledgment of a write command, soft reset or hard reset does not affect its operation. But power off terminates writing operation immediately and unwritten data are to be lost.
- Soft reset and Check Power Mode command is executed after the completion of writing to disk media on enabling write cache function. So the host system can confirm the completion of write cache operation by issuing Soft reset or Check Power Mode command and then confirming its completion. We developer of the device recommend that a host system checks the completion of write cache operation by issuing Soft reset or Check Power Mode command to the device before power off.
- The retry bit of Write Sectors is ignored when write cache is enabled.

---

## 10.10 Reassign Function

Reassign Function is used with FORMAT TRACK command, read with retry commands and write commands. The sectors of data for reassignment are prepared as the spare data sector. The assured number of the spare sectors is minimum 526 sectors.

This reassignment information is registered internally, and the information is available right after completing the reassign function. Also the information is used on next power on reset or hard reset.

If the number of the spare sector reaches 0 sector, the reassign function will be disabled automatically.

The spare sectors for reassignment are located at the end of device. As a result of reassignment, the physical location of logically sequenced sectors will be dispersed.

### 10.10.1 Auto Reassign Function

The sectors those show some errors may be reallocated automatically when specific conditions are met. The spare sectors for reallocation are located at the end of drive. The conditions for auto-reallocation are described below.

When a device shipped from IBM, minimum 526 of usable spare sectors are available.

#### **Non recovered write errors**

When a write operation can not be completed after the Error Recovery Procedure(ERP) is fully carried out, the sector(s) are reallocated to the spare location. An error is reported to the host system only when the write cache is disabled and the auto reallocation is failed.

If the number of available spare sectors reaches 16 sectors, the write cache function will be disabled automatically.

If the command is without retry and the write cache function is disabled, the auto reassign function is not invoked.

#### **Non recovered read errors**

When a read operation is failed after defined ERP is fully carried out, a hard error is reported to the host system. This location is registered internally as a candidate for the reallocation. When a registered location is specified as a target of a write operation, a sequence of media verification is performed automatically. When the result of this verification meets the criteria, this sector is reallocated.

#### **Recovered read errors**

When a read operation for a sector failed once then recovered at the specific ERP step, this sector of data is reallocated automatically. A media verification sequence may be run prior to the relocation according to the pre-defined conditions.



---

## 11.0 Command Protocol

The commands are grouped into different classes according to the protocols followed for command execution. The command classes with their associated protocols are defined below.

For all commands, the host must first check if BSY=1, and should proceed no further unless and until BSY=0. For all commands, the host must also wait for RDY=1 before proceeding.

A device must maintain either BSY=1 or DRQ=1 at all times until the command is completed. The INTRQ signal is used by the device to signal most, but not all, times when the BSY bit is changed from 1 to 0 during command execution.

A command shall only be interrupted with a hardware or software reset. The result of writing to the Command register while BSY=1 or DRQ=1 is unpredictable and may result in data corruption. A command should only be interrupted by a reset at times when the host thinks there may be a problem, such as a device that is no longer responding.

Interrupts are cleared when the host reads the Status Register, issues a reset, or writes to the Command Register.

Figure 99 on page 153 shows the device timeout values.

---

### 11.1 Data In Commands

These commands are:

- Identify Device
- Read Buffer
- Read Long
- Read Multiple
- Read Sectors
- SMART Read Attribute Values
- SMART Read Attribute Thresholds

Execution includes the transfer of one or more 512 byte (>512 bytes on Read Long) sectors of data from the device to the host.

1. The host writes any required parameters to the Features, Sector Count, Sector Number, Cylinder, and Device/Head Registers.
2. The host writes the command code to the Command Register.
3. For each sector (or block) of data to be transferred:
  - a. The device sets BSY=1 and prepares for data transfer.
  - b. When a sector (or block) of data is available for transfer to the host, the device sets BSY=0, sets DRQ=1, and interrupts the host.
  - c. In response to the interrupt, the host reads the Status Register.
  - d. The device clears the interrupt in response to the Status Register being read.
  - e. The host reads one sector (or block) of data via the Data Register.

- f. The device sets DRQ=0 after the sector (or block) has been transferred to the host.
4. For the Read Long command:
    - a. The device sets BSY=1 and prepares for data transfer.
    - b. When the sector of data is available for transfer to the host, the device sets BSY=0, sets DRQ=1, and interrupts the host.
    - c. In response to the interrupt, the host reads the Status Register.
    - d. The device clears the interrupt in response to the Status Register being read.
    - e. The host reads the sector of data including ECC bytes via the Data Register.
    - f. The device sets DRQ=0 after the sector has been transferred to the host.

The Read Multiple command transfers one block of data for each interrupt. The other commands transfer one sector of data for each interrupt.

Note that the status data for a sector of data is available in the Status Register **before** the sector is transferred to the host.

If the device detects an invalid parameter, then it will abort the command by setting BSY=0, ERR=1, ABT=1, and interrupting the host.

If an error occurs, the device will set BSY=0, ERR=1, and DRQ=1. The device will then store the error status in the Error Register, and interrupt the host. The registers will contain the location of the sector in error. The errored location will be reported with CHS mode or LBA mode, the mode is decided by mode select bit (bit 6) of Device/Head register on issuing the command.

If an Uncorrectable Data Error (UNC=1) occurs, the defective data will be transferred from the media to the sector buffer, and will be available to be transferred to the host, at the host's option. In case of Read Multiple command, the host should complete transfer the block which includes error from the sector buffer and terminate whatever kind of type of error occurred.

If an error occurs that is correctable by retries, the data will be corrected and the transfer will continue normally. There will be no indication to the host that any retry occurred.

All data transfers to the host through the Data Register are 16 bits, except for the ECC bytes, which are 8 bits.

---

## 11.2 Data Out Commands

These commands are:

- Format Track
- Security Disable Password
- Security Erase Unit
- Security Set Password
- Security Unlock
- Write Buffer
- Write Long
- Write Multiple

- Write Sectors
- Write Verify

Execution includes the transfer of one or more 512 byte (>512 bytes on Write Long) sectors of data from the host to the device.

1. The host writes any required parameters to the Features, Sector Count, Sector Number, Cylinder, and Device/Head Registers.
2. The host writes the command code to the Command Register.
3. The device sets BSY=1.
4. For each sector (or block) of data to be transferred:
  - a. The device sets BSY=0 and DRQ=1 when it is ready to receive a sector (or block).
  - b. The host writes one sector (or block) of data via the Data Register.
  - c. The device sets BSY=1 after it has received the sector (or block).
  - d. When the device has finished processing the sector (or block), it sets BSY=0, and interrupts the host.
  - e. In response to the interrupt, the host reads the Status Register.
  - f. The device clears the interrupt in response to the Status Register being read.
5. For the Write Long command:
  - a. The device sets BSY=0 and DRQ=1 when it is ready to receive a sector.
  - b. The host writes one sector of data including ECC bytes via the Data Register.
  - c. The device sets BSY=1 after it has received the sector.
  - d. After processing the sector of data the device sets BSY=0 and interrupts the host.
  - e. In response to the interrupt, the host reads the Status Register.
  - f. The device clears the interrupt in response to the Status Register being read.

The Write Multiple command transfers one block of data for each interrupt. The other commands transfer one sector of data for each interrupt.

If the device detects an invalid parameter, then it will abort the command by setting BSY=0, ERR=1, ABT=1, and interrupting the host.

If an uncorrectable error occurs, the device will set BSY=0 and ERR=1, store the error status in the Error Register, and interrupt the host. The registers will contain the location of the sector in error. The errored location will be reported with CHS mode or LBA mode, the mode is decided by mode select bit (bit 6) of Device/Head register on issuing the command.

All data transfers to the device through the Data Register are 16 bits, except for the ECC bytes, which are 8 bits.

---

## 11.3 Non-Data Commands

These commands are:

- Check Power Mode
- Execute Device Diagnostic
- Format Unit
- Idle
- Idle Immediate
- Initialize Device Parameters
- Read Native Max LBA/CYL
- Read Verify Sectors
- Recalibrate
- Security Erase Prepare
- Security Freeze Lock
- Seek
- Set Features
- Set Max LBA/CYL
- Set Multiple Mode
- Sleep
- SMART Disable Operations
- SMART Enable/Disable Attribute Autosave
- SMART Enable Operations
- SMART Execute Off-line Data Collection
- SMART Return Status
- SMART Save Attribute Values
- Standby
- Standby Immediate

Execution of these commands involves no data transfer.

1. The host writes any required parameters to the Features, Sector Count, Sector Number, Cylinder, and Device/Head Registers.
2. The host writes the command code to the Command Register.
3. The device sets BSY=1.
4. When the device has finished processing the command, it sets BSY=0, and interrupts the host.
5. In response to the interrupt, the host reads the Status Register.
6. The device clears the interrupt in response to the Status Register being read.

---

## 11.4 DMA Data Transfer Commands

These commands are:

- Identify Device DMA
- Read DMA
- Write DMA

Data transfer using DMA commands differ in two ways from PIO transfers:

- data transfers are performed using the slave-DMA channel
- no intermediate sector interrupts are issued on multi-sector commands

Initiation of the DMA transfer commands is identical to the Read Sector or Write Sector commands except that the host initializes the slave-DMA channel prior to issuing the command.

The interrupt handler for DMA transfers is different in that:

- no intermediate sector interrupts are issued on multi-sector commands
- the host resets the DMA channel prior to reading status from the device.

The DMA protocol allows high performance multi-tasking operating systems to eliminate processor overhead associated with PIO transfers.

1. Host initializes the slave-DMA channel
2. Host writes any required parameters to the Features, Sector Count, Sector Number, Cylinder and Device/Head registers.
3. Host writes command code to the Command Register
4. The device sets DMARQ when it is ready to transfer any part of the data.
5. Host transfers the data using the DMA transfer protocol currently in effect.
6. When all of the data has been transferred, the device generates an interrupt to the host.
7. Host resets the slave-DMA channel
8. Host reads the Status Register and, optionally, the Error Register



## 12.0 Command Descriptions

Proto col	Command	Code (Hex)	Binary Code Bit							
			7	6	5	4	3	2	1	0
3	Check Power Mode	E5	1	1	1	0	0	1	0	1
3	Check Power Mode*	98	1	0	0	1	1	0	0	0
3	Execute Device Diagnostic	90	1	0	0	1	0	0	0	0
2	Format Track	50	0	1	0	1	0	0	0	0
3+	Format Unit	F7	1	1	1	1	0	1	1	1
1	Identify Device	EC	1	1	1	0	1	1	0	0
4	Identify Device DMA	EE	1	1	1	0	1	1	1	0
3	Idle	E3	1	1	1	0	0	0	1	1
3	Idle*	97	1	0	0	1	0	1	1	1
3	Idle Immediate	E1	1	1	1	0	0	0	0	1
3	Idle Immediate*	95	1	0	0	1	0	1	0	1
3	Initialize Device Parameters	91	1	0	0	1	0	0	0	1
1	Read Buffer	E4	1	1	1	0	0	1	0	0
4	Read DMA (retry)	C8	1	1	0	0	1	0	0	0
4	Read DMA (no retry)	C9	1	1	0	0	1	0	0	1
1	Read Long (retry)	22	0	0	1	0	0	0	1	0
1	Read Long (no retry)	23	0	0	1	0	0	0	1	1
1	Read Multiple	C4	1	1	0	0	0	1	0	0
3+	Read Native Max LBA/CYL	F8	1	1	1	1	1	0	0	0
1	Read Sectors (retry)	20	0	0	1	0	0	0	0	0
1	Read Sectors (no retry)	21	0	0	1	0	0	0	0	1
3	Read Verify Sectors (retry)	40	0	1	0	0	0	0	0	0
3	Read Verify Sectors (no retry)	41	0	1	0	0	0	0	0	1
3	Recalibrate	1x	0	0	0	1	—	—	—	—
2	Security Disable Password	F6	1	1	1	1	1	0	1	0
3	Security Erase Prepare	F3	1	1	1	1	0	0	1	1
2	Security Erase Unit	F4	1	1	1	1	0	1	0	0
3	Security Freeze Lock	F5	1	1	1	1	0	1	0	1
2	Security Set Password	F1	1	1	1	1	0	0	0	1
2	Security Unlock	F2	1	1	1	1	0	0	1	0
3	Seek	7x	0	1	1	1	—	—	—	—
3	Set Features	EF	1	1	1	0	1	1	1	1
3+	Set Max LBA/CYL	F9	1	1	1	1	1	0	0	1
3	Set Multiple Mode	C6	1	1	0	0	0	1	1	0

Figure 46. Command Set

Protocol	Command	Code (Hex)	Binary Code Bit							
			7	6	5	4	3	2	1	0
3	Sleep	E6	1	1	1	0	0	1	1	0
3	Sleep*	99	1	0	0	1	1	0	0	1
3	SMART Disable Operations	B0	1	0	1	1	0	0	0	0
3	SMART Enable/Disable Attribute Autosave	B0	1	0	1	1	0	0	0	0
3	SMART Enable Operations	B0	1	0	1	1	0	0	0	0
3	SMART Execute Off-line Data Collection	B0	1	0	1	1	0	0	0	0
1	SMART Read Attribute Values	B0	1	0	1	1	0	0	0	0
1	SMART Read Attribute Thresholds	B0	1	0	1	1	0	0	0	0
3	SMART Return Status	B0	1	0	1	1	0	0	0	0
3	SMART Save Attribute Values	B0	1	0	1	1	0	0	0	0
3	Standby	E2	1	1	1	0	0	0	1	0
3	Standby*	96	1	0	0	1	0	1	1	0
3	Standby Immediate	E0	1	1	1	0	0	0	0	0
3	Standby Immediate*	94	1	0	0	1	0	1	0	0
2	Write Buffer	E8	1	1	1	0	1	0	0	0
4	Write DMA (retry)	CA	1	1	0	0	1	0	1	0
4	Write DMA (no retry)	CB	1	1	0	0	1	0	1	1
2	Write Long (retry)	32	0	0	1	1	0	0	1	0
2	Write Long (no retry)	33	0	0	1	1	0	0	1	1
2	Write Multiple	C5	1	1	0	0	0	1	0	1
2	Write Sectors (retry)	30	0	0	1	1	0	0	0	0
2	Write Sectors (no retry)	31	0	0	1	1	0	0	0	1
2	Write Verify	3C	0	0	1	1	1	1	0	0

Protocol : 1 : PIO data IN command  
 2 : PIO data OUT command  
 3 : Non data command  
 4 : DMA command  
 + : Vendor specific command

Figure 47. Command Set - continued

Commands marked \* are alternate command codes for previous defined commands.

Command (Subcommand)	Command Code (Hex)	Feature Register (Hex)
(S.M.A.R.T function)		
SMART Read Attribute Values	B0	D0
SMART Read Attribute Thresholds	B0	D1
SMART Enable/Disable Attribute Autosave	B0	D2
SMART Save Attribute Values	B0	D3
SMART Execute Off-line Data Collection	B0	D4
SMART Enable Operations	B0	D8
SMART Disable Operations	B0	D9
SMART Return Status	B0	DA
(Set Features)		
Enable Write Cache	EF	02
Set Transfer Mode	EF	03
20 bytes of ECC apply on Read/Write Long	EF	44
Disable read look-ahead feature	EF	55
Disable reverting to power on defaults	EF	66
Disable write cache	EF	82
Enable read look-ahead feature	EF	AA
4 bytes of ECC apply on Read/Wrtie Long	EF	BB
Enable reverting to power on defaults	EF	CC

Figure 48. Command Set (Subcommand)

Figure 46 on page 79 and Figure 47 on page 80 shows the commands that are supported by the device. Figure 48 shows the sub-commands that are supported by each command or feature.

The following symbols are used in the command descriptions:

#### **Output Registers**

- 0** Indicates that the bit must be set to 0.
- 1** Indicates that the bit must be set to 1.
- D** The device number bit. Indicates that the device number bit of the Device/Head Register should be specified. Zero selects the master device and one selects the slave device.
- H** Head number. Indicates that the head number part of the Device/Head Register is an output parameter and should be specified.
- L** LBA mode. Indicates the addressing mode. Zero specifies CHS mode and one does LBA addressing mode.
- R** Retry. Indicates that the Retry bit of the Command Register should be specified.
- B** Option Bit. Indicates that the Option Bit of the Sector Count Register should be specified. (This bit is used by Set Max LBA/CYL command)
- V** Valid. Indicates that the bit is part of an output parameter and should be specified.
- x** Indicates that the hex character is not used.
- Indicates that the bit is not used.

#### **Input Registers**

- 0** Indicates that the bit is always set to 0.
- 1** Indicates that the bit is always set to 1.
- H** Head number. Indicates that the head number part of the Device/Head Register is an input parameter and will be set by the device.
- V** Valid. Indicates that the bit is part of an input parameter and will be set to 0 or 1 by the device.
- Indicates that the bit is not part of an input parameter.

The command descriptions show the contents of the Status and Error Registers after the device has completed processing the command and has interrupted the host.

## 12.1 Check Power Mode (E5h/98h)

Command Block Output Registers								
Register	7	6	5	4	3	2	1	0
Data	-	-	-	-	-	-	-	-
Feature	-	-	-	-	-	-	-	-
Sector Count	-	-	-	-	-	-	-	-
Sector Number	-	-	-	-	-	-	-	-
Cylinder Low	-	-	-	-	-	-	-	-
Cylinder High	-	-	-	-	-	-	-	-
Device/Head	1	-	1	D	-	-	-	-
Command	1	1	1	0	0	1	0	1

Command Block Input Registers								
Register	7	6	5	4	3	2	1	0
Data	-	-	-	-	-	-	-	-
Error	...See Below...							
Sector Count	V	V	V	V	V	V	V	V
Sector Number	-	-	-	-	-	-	-	-
Cylinder Low	-	-	-	-	-	-	-	-
Cylinder High	-	-	-	-	-	-	-	-
Device/Head	-	-	-	-	-	-	-	-
Status	...See Below...							

Error Register							
7	6	5	4	3	2	1	0
BBK	UNC	0	IDN	0	ABT	T0N	AMN
0	0	0	0	0	V	0	0

Status Register							
7	6	5	4	3	2	1	0
BSY	RDY	DF	DSC	DRQ	COR	IDX	ERR
0	0	0	-	-	0	-	V

Figure 49. Check Power Mode Command (E5h/98h)

The Check Power Mode command will report whether the device is spun up and the media is available for immediate access.

### Input Parameters From The Device

**Sector Count** The power mode code. The command returns FFh in the Sector Count Register if the spindle motor is at speed and the device is not in Standby or Sleep mode. Otherwise, the Sector Count Register will be set to 0.

## 12.2 Execute Device Diagnostic (90h)

Command Block Output Registers								
Register	7	6	5	4	3	2	1	0
Data	-	-	-	-	-	-	-	-
Feature	-	-	-	-	-	-	-	-
Sector Count	-	-	-	-	-	-	-	-
Sector Number	-	-	-	-	-	-	-	-
Cylinder Low	-	-	-	-	-	-	-	-
Cylinder High	-	-	-	-	-	-	-	-
Device/Head	1	-	1	D	-	-	-	-
Command	1	0	0	1	0	0	0	0

Command Block Input Registers								
Register	7	6	5	4	3	2	1	0
Data	-	-	-	-	-	-	-	-
Error	...See Below...							
Sector Count	-	-	-	-	-	-	-	-
Sector Number	-	-	-	-	-	-	-	-
Cylinder Low	-	-	-	-	-	-	-	-
Cylinder High	-	-	-	-	-	-	-	-
Device/Head	-	-	-	-	-	-	-	-
Status	...See Below...							

Error Register							
7	6	5	4	3	2	1	0
BBK	UNC	0	IDN	0	ABT	T0N	AMN
V	V	V	V	V	V	V	V

Status Register							
7	6	5	4	3	2	1	0
BSY	RDY	DF	DSC	DRQ	COR	IDX	ERR
0	0	0	-	-	0	-	0

Figure 50. Execute Device Diagnostic Command (90h)

The Execute Device Diagnostic command performs the internal diagnostic tests implemented by the device. The results of the test are stored in the Error Register.

The normal Error Register bit definitions do not apply to this command. Instead, the register contains a diagnostic code. See Figure 38 on page 55 for the definition.

## 12.3 Format Track (50h: Vendor Specific)

Command Block Output Registers								
Register	7	6	5	4	3	2	1	0
Data	-	-	-	-	-	-	-	-
Feature	-	-	-	-	-	-	-	-
Sector Count	-	-	-	-	-	-	-	-
Sector Number	V	V	V	V	V	V	V	V
Cylinder Low	V	V	V	V	V	V	V	V
Cylinder High	V	V	V	V	V	V	V	V
Device/Head	1	-	1	D	H	H	H	H
Command	0	1	0	1	0	0	0	0

Command Block Input Registers								
Register	7	6	5	4	3	2	1	0
Data	-	-	-	-	-	-	-	-
Error	...See Below...							
Sector Count	-	-	-	-	-	-	-	-
Sector Number	V	V	V	V	V	V	V	V
Cylinder Low	V	V	V	V	V	V	V	V
Cylinder High	V	V	V	V	V	V	V	V
Device/Head	-	-	-	-	H	H	H	H
Status	...See Below...							

Error Register							
7	6	5	4	3	2	1	0
BBK	UNC	0	IDN	0	ABT	T0N	AMN
0	0	0	V	0	V	0	0

Status Register							
7	6	5	4	3	2	1	0
BSY	RDY	DF	DSC	DRQ	COR	IDX	ERR
0	V	V	V	-	0	-	V

Figure 51. Format Track Command (50h)

The Format Track command formats a single logical track on the device. Each good sector of data on the track will be initialized to zero with write operation. At this time, the sector of data is not verified with read operation whether the sector of data is initialized correctly. Any data previously stored on the track will be lost.

The host transfers a sector of data containing a format table to the device. The format table should contain two bytes for each sector on the track to be formatted. The structure of format table is shown in Figure 52 on page 87. The first byte should contain a descriptor value and the second byte should contain the sector number. The descriptor value should be 0 for a good sector, 20h for an unassign sector, 40h for an assign sector, 80h for a bad sector, and any other descriptor value will cause an aborted error. The remaining bytes of the sector following the format table are ignored.

Since device performance is optimal at 1:1 interleave, and the device uses relative block addressing internally, the device will always format a track in the same way no matter what sector numbering is specified in the format table.

### Output Parameters To The Device

**Sector Number** In LBA mode, this register specifies LBA address bits 0 - 7 to be formatted. (L=1)

**Cylinder High/Low** The cylinder number of the track to be formatted. (L=0)

In LBA mode, this register specifies LBA address bits 8 - 15 (Low), 16 - 23 (High) to be formatted. (L=1)

**H** The head number of the track to be formatted. (L=0)  
In LBA mode, this register specifies LBA address bits 24 - 27 to be formatted. (L=1)

#### **Input Parameters From The Device**

**Sector Number** In LBA mode, this register specifies current LBA address bits 0-7. (L=1)

**Cylinder High/Low** In LBA mode, this register specifies current LBA address bits 8 - 15 (Low), 16 - 23 (High)

**H** In LBA mode, this register specifies current LBA address bits 24 - 27. (L=1)

**Error** The Error Register. An Abort error (ABT=1) will be returned under the following conditions:

- The descriptor value does not match the certain value. (except 00h, 20h, 40h and 80h)
- The number of assign(40h) exceeds the maximum number of reassign table entry.
- No spare data sector to be assigned.

In LBA mode, this command formats a single logical track including the specified LBA.

#### **Explanation for descriptor**

**Descriptor : 00h** The sector of data will be initialized to 00h.

**Descriptor : 20h** The sector will be unassigned to the original location from the reassigned location.

**Descriptor : 40h** The sector will be assigned to a spare data sector. When being accessed by next command, the spare sector of data will be used automatically. The assigned sector can be unassigned with a descriptor 20h.

**Descriptor : 80h** The sector will be registered as a bad sector. Thereafter, the sector reports BAD BLOCK to ERROR Register on Read commands. But the sector will not report BAD BLOCK if the sector is written by Write commands.

Byte	Data	Description
0 1	xxh 00h	descriptor value for sector number 00h sector number
2 3	xxh 01h	descriptor value for sector number 01h sector number
4 5	xxh 02h	descriptor value for sector number 02h sector number
:	:	
:	:	
N*2 N*2+1	xxh N	descriptor value for sector number N sector number (last sector for the track)
N*2+2 N*2+3 : : 510 511	00h 00h : : 00h 00h	remainder of buffer filled with 00h

Descriptor : 00h – Format sector as good sector  
20h – Unassign the alternate location for this sector  
40h – Assign this sector to an alternate location  
80h – Format sector as bad sector

Figure 52. Format track data field format

## 12.4 Format Unit (F7h: Vendor Specific)

Command Block Output Registers								
Register	7	6	5	4	3	2	1	0
Data	-	-	-	-	-	-	-	-
Feature	V	V	V	V	V	V	V	V
Sector Count	-	-	-	-	-	-	-	-
Sector Number	-	-	-	-	-	-	-	-
Cylinder Low	-	-	-	-	-	-	-	-
Cylinder High	-	-	-	-	-	-	-	-
Device/Head	1	0	1	D	-	-	-	-
Command	1	1	1	1	0	1	1	1

Command Block Input Registers								
Register	7	6	5	4	3	2	1	0
Data	-	-	-	-	-	-	-	-
Error	...See Below...							
Sector Count	-	-	-	-	-	-	-	-
Sector Number	-	-	-	-	-	-	-	-
Cylinder Low	-	-	-	-	-	-	-	-
Cylinder High	-	-	-	-	-	-	-	-
Device/Head	-	-	-	-	-	-	-	-
Status	...See Below...							

Error Register							
7	6	5	4	3	2	1	0
BBK	UNC	0	IDN	0	ABT	T0N	AMN
0	0	0	V	0	V	0	0

Status Register							
7	6	5	4	3	2	1	0
BSY	RDY	DF	DSC	DRQ	COR	IDX	ERR
0	V	0	V	-	0	-	V

Figure 53. Format Unit Command (F7h)

The Format Unit command initializes all user data sectors after merging reassigned sector location into the defect information of the device and clearing the reassign information. Both new reassign information and new defect information are available right after this command completion, and are also used on next power on reset or hard reset. Both previous information are erased from the device by this command.

Note that the Format Unit command initializes from LBA 0 to Native MAX LBA. Host MAX LBA set by Initialize Drive Parameter or Set MAX LBA/CYL command is ignored. So the protected area by Set MAX LBA/CYL command is also initialized.

If Feature register is NOT 11h, the device returns Abort error to the host.

This command does not request to data transfer.

### Output Parameters To The Device

**Feature** Destination code for this command.  
**11H** Merge reassigned location into the defect information

The execution time of this command is shown below.

**DMCA-21440** about 6min.50sec.  
**DMCA-21080** about 5min.10sec.

## 12.5 Identify Device (ECh)

Command Block Output Registers								
Register	7	6	5	4	3	2	1	0
Data	-	-	-	-	-	-	-	-
Feature	-	-	-	-	-	-	-	-
Sector Count	-	-	-	-	-	-	-	-
Sector Number	-	-	-	-	-	-	-	-
Cylinder Low	-	-	-	-	-	-	-	-
Cylinder High	-	-	-	-	-	-	-	-
Device/Head	1	-	1	D	-	-	-	-
Command	1	1	1	0	1	1	0	0

Command Block Input Registers								
Register	7	6	5	4	3	2	1	0
Data	-	-	-	-	-	-	-	-
Error	...See Below...							
Sector Count	-	-	-	-	-	-	-	-
Sector Number	-	-	-	-	-	-	-	-
Cylinder Low	-	-	-	-	-	-	-	-
Cylinder High	-	-	-	-	-	-	-	-
Device/Head	-	-	-	-	-	-	-	-
Status	...See Below...							

Error Register							
7	6	5	4	3	2	1	0
BBK	UNC	0	IDN	0	ABT	T0N	AMN
0	0	0	0	0	V	0	0

Status Register							
7	6	5	4	3	2	1	0
BSY	RDY	DF	DSC	DRQ	COR	IDX	ERR
0	V	0	-	-	0	-	V

Figure 54. Identify Device Command (ECh)

The Identify Device command requests the device to transfer configuration information to the host. The device will transfer a sector to the host containing the information in Figure 55 on page 90.

Word	Content	Description
00	045AH	Drive classification, bit assignments: 15(=0): 1=ATAPI device, 0=ATA device * 14(=0): 1=format speed tolerance gap required * 13(=0): 1=track offset option available * 12(=0): 1=data strobe offset option available * 11(=0): 1=rotational speed tolerance > 0.5% * 10(=1): 1=disk transfer rate > 10 Mbps * 9(=0): 1=disk transfer rate > 5 Mbps but <= 10 Mbps * 8(=0): 1=disk transfer rate <= 5 Mbps 7(=0): 1=removable cartridge device 6(=1): 1=fixed device * 5(=0): 1=spindle motor control option implemented * 4(=1): 1=head switch time > 15 us * 3(=1): 1=not MFM encoded * 2(=0): 1=soft sectoring * 1(=1): 1=hard sectoring 0(=0): Reserved
01	Note 1	Number of cylinders in default translate mode
02	0	* Number of removable cylinders
03	0010H	Number of heads in default translate mode
04	0	* Reserved
05	0	* Reserved
06	003FH	Number of sectors per track in default translate mode
07	0000H	* Number of bytes of sector gap
08	0000H	* Number of bytes in sync field
09	0000H	* Reserved
10-19	XXXX	Serial number in ASCII (0 = not specified)
20	0003H	* Controller type: 0003: dual ported, multiple sector buffer with look-ahead read
21	00C0H	* Buffer size in 512-byte increments (=96KB)
22	00XXH	Number of ECC bytes as currently selected via the set features command
23-26	XXXX	Microcode version in ASCII
27-46	Note 2	Model number in ASCII
47	0010H	Maximum number of sectors that can be transferred per interrupt on Read and Write Multiple commands
48	0000H	Capable of double word I/O, '0000'= cannot perform
49	0F00H	Capabilities, bit assignments: 15-14(=0) Reserved 13(=0) Standby timer value are vendor specific 12(=0) Reserved 11(=1) IORDY Supported 10(=1) IORDY can be disabled 9(=1) 1=LBA Supported 8(=1) 1=DMA Supported * 7- 0(=0) Reserved
50	0000H	15(=0) 1=Security Mode Feature Set Supported 14- 8(=0) Maximum number of passwords supported

Figure 55. Identify device information

Word	Content	Description
51	0200H	PIO data transfer cycle timing mode
52	0200H	DMA data transfer cycle timing mode Refer Word 62 and 63
53	0003H	Validity flag of the word 15- 2(=0) Reserved 1(=1) 1=Word 64-70 are Valid 0(=1) 1=Word 54-58 are Valid
54	XXXXH	Number of current cylinders
55	XXXXH	Number of current heads
56	XXXXH	Number of current sectors per track
57-58	XXXXH	Current capacity in sectors Word 57 specifies the low word of the capacity
59	0XXXH	Current Multiple setting. bit assignments 15- 9(=0) Reserved 8 1= Multiple Sector Setting is Valid 7- 0 xxh = Current setting for number of sectors
60-61	Note 3	Total Number of User Addressable Sectors Word 60 specifies the low word of the number
62	XX07H	Single Word DMA Transfer Capability 15- 8 Single word DMA transfer mode active 7- 0(=7) Single word DMA transfer modes supported (support mode 0,1 and 2)
63	Note 4	Multiword DMA Transfer Capability 15- 8 Multiword DMA transfer mode active 7- 0(=3) Multiword DMA Mode 0 and 1 supported 7- 0(=7) Multiword DMA Mode 0, 1 and 2 supported
64	0003H	Flow Control PIO Transfer Modes Supported 15- 8(=0) Reserved 7- 0(=3) Advanced PIO Transfer Modes Supported '11' = PIO Mode 3 and 4 Supported
65	Note 5	Minimum Multiword DMA Transfer Cycle Time
66	Note 5	Manufacturer's Recommended Multiword DMA Transfer Cycle Time
67	00F0H	Minimum PIO Transfer Cycle Time Without Flow Control 15- 0(=F0) Cycle time in nanoseconds (240ns, 8.3MB/s)
68	0078H	Minimum PIO Transfer Cycle Time With IORDY Flow Control 15- 0(=78) Cycle time in nanoseconds (120ns, 16.6MB/s)
69-79	0000H	Reserved
80	000EH	Major version number 15- 0(=0E) ATA-1, ATA-2 and ATA-3
81	0006H	Minor version number 15- 0(=06) ATA-3 X3T10 2008D revision 1
82	000BH	Command set supported 15- 4(=0) Reserved 3(=1) 1=supports Power Management Feature Set 2(=0) 1=supports Removable Feature Set 1(=1) 1=supports Security Feature Set 0(=1) 1=supports S.M.A.R.T Feature Set
83	4000H	Command set supported 15(=0) Always 14(=1) Always 13- 0(=0) Reserved

Figure 56. Identify device information --- Continued ---

Word	Content	Description
84-127	0000H	Reserved
128	XXXXH	Security Mode Feature. Bit assignments 0 Capability 1= Support 1 Enable/Disable 1= Enable 2 Lock 1= Locked 3 Freeze 1= Frozen 4 Expire 1= Expired 8 Security Level 1= Maximum, 0= High 9-15 Reserved
129	XXXXH *	Current Set Feature Option. Bit assignments 0 Write Cache 1= Enable 1 Read Look-ahead 1= Enable 2 Reverting 1= Enable 3 Auto reassign 1= Enable 4-15 Reserved
130	XXXXH *	Reserved
131	000XH *	Initial Power Mode Selection. Bit assignments 0 Initial Power Mode 1= Standby, 0= Idle 1-15 Reserved
132-255	0000H	Reserved

Figure 57. Identify device information --- Continued ---

**Note.** The '\*' mark in 'Content' field indicates the use of the parameter is vendor specific.

**Note 1.** The number of cylinders is  
0AF0H for DMCA-21440,  
0834H for DMCA-21080.

**Note 2.** The model number in ASCII is  
'IBM-DMCA-21440' for DMCA-21440,  
'IBM-DMCA-21080' for DMCA-21080.

**Note 3.** Total number of user addressable sectors is  
2B1100H for DMCA-21440,  
204CC0H for DMCA-21080.

| **Note 4.** Earlier versions of the drive only provided support for Mode-1 rather than Mode-2 transfers when  
| operated in DMA Multiword mode.

| This information is specified in the Identify Device data, word 63.

| If the drive reports this word as xx03H, it returns then only DMA Multiword mode 0 and 1 are supported.

| If the drive reports this word as xx07H, it returns then DMA Multiword mode 0, 1 and 2 are supported.

| **Note 5.** DMCA-2xxxx has two versions on Multiword DMA as described in Note 4. The word 65 and 66  
| are as follows.

- | • Word 65 = Word 66 = 0078H (120ns) : Multiword DMA Mode 2 support version.
- | • Word 65 = Word 66 = 00F0H (240ns) : Multiword DMA Mode 1 support version.

## 12.6 Identify Device DMA (EEh)

Command Block Output Registers								
Register	7	6	5	4	3	2	1	0
Data	-	-	-	-	-	-	-	-
Feature	-	-	-	-	-	-	-	-
Sector Count	-	-	-	-	-	-	-	-
Sector Number	-	-	-	-	-	-	-	-
Cylinder Low	-	-	-	-	-	-	-	-
Cylinder High	-	-	-	-	-	-	-	-
Device/Head	1	-	1	D	-	-	-	-
Command	1	1	1	0	1	1	1	0

Command Block Input Registers								
Register	7	6	5	4	3	2	1	0
Data	-	-	-	-	-	-	-	-
Error	...See Below...							
Sector Count	-	-	-	-	-	-	-	-
Sector Number	-	-	-	-	-	-	-	-
Cylinder Low	-	-	-	-	-	-	-	-
Cylinder High	-	-	-	-	-	-	-	-
Device/Head	-	-	-	-	-	-	-	-
Status	...See Below...							

Error Register							
7	6	5	4	3	2	1	0
BBK	UNC	0	IDN	0	ABT	T0N	AMN
0	0	0	0	0	V	0	0

Status Register							
7	6	5	4	3	2	1	0
BSY	RDY	DF	DSC	DRQ	COR	IDX	ERR
0	V	0	-	-	0	-	V

Figure 58. Identify Device Command DMA (EEh)

The Identify Device DMA command requests the device to transfer configuration information to the host. The device will transfer the same 256 words of device identification data by the Identify Device command(ECh) via DMA channel.

## 12.7 Idle (E3h/97h)

Command Block Output Registers								
Register	7	6	5	4	3	2	1	0
Data	-	-	-	-	-	-	-	-
Feature	-	-	-	-	-	-	-	-
Sector Count	V	V	V	V	V	V	V	V
Sector Number	-	-	-	-	-	-	-	-
Cylinder Low	-	-	-	-	-	-	-	-
Cylinder High	-	-	-	-	-	-	-	-
Device/Head	1	-	1	D	-	-	-	-
Command	1	1	1	0	0	0	1	1

Command Block Input Registers								
Register	7	6	5	4	3	2	1	0
Data	-	-	-	-	-	-	-	-
Error	...See Below...							
Sector Count	-	-	-	-	-	-	-	-
Sector Number	-	-	-	-	-	-	-	-
Cylinder Low	-	-	-	-	-	-	-	-
Cylinder High	-	-	-	-	-	-	-	-
Device/Head	-	-	-	-	-	-	-	-
Status	...See Below...							

Error Register							
7	6	5	4	3	2	1	0
BBK	UNC	0	IDN	0	ABT	T0N	AMN
0	0	0	0	0	V	0	0

Status Register							
7	6	5	4	3	2	1	0
BSY	RDY	DF	DSC	DRQ	COR	IDX	ERR
0	V	0	V	-	0	-	V

Figure 59. Idle Command (E3h/97h)

The Idle command causes the device to enter Idle mode immediately, and set auto power down timeout parameter(standby timer). And then the timer starts counting down.

When the Idle mode is entered, the device is spun up to operating speed. If the device is already spinning, the spin up sequence is not executed.

During Idle mode the device is spinning and ready to respond to host commands immediately.

### Output Parameters To The Device

**Sector Count** Timeout Parameter. If zero, the timeout interval(Standby Timer) is NOT disabled, but the timeout interval is set for 109 minutes automatically. If other than zero, the timeout interval is set for (Timeout Parameter × 5) seconds.

The device will enter Standby mode automatically if the timeout interval expires with no device access from the host. The timeout interval will be reinitialized if there is a device access before the timeout interval expires.

## 12.8 Idle Immediate (E1h/95h)

Command Block Output Registers								
Register	7	6	5	4	3	2	1	0
Data	-	-	-	-	-	-	-	-
Feature	-	-	-	-	-	-	-	-
Sector Count	-	-	-	-	-	-	-	-
Sector Number	-	-	-	-	-	-	-	-
Cylinder Low	-	-	-	-	-	-	-	-
Cylinder High	-	-	-	-	-	-	-	-
Device/Head	1	-	1	D	-	-	-	-
Command	1	1	1	0	0	0	0	1

Command Block Input Registers								
Register	7	6	5	4	3	2	1	0
Data	-	-	-	-	-	-	-	-
Error	...See Below...							
Sector Count	-	-	-	-	-	-	-	-
Sector Number	-	-	-	-	-	-	-	-
Cylinder Low	-	-	-	-	-	-	-	-
Cylinder High	-	-	-	-	-	-	-	-
Device/Head	-	-	-	-	-	-	-	-
Status	...See Below...							

Error Register							
7	6	5	4	3	2	1	0
BBK	UNC	0	IDN	0	ABT	T0N	AMN
0	0	0	0	0	V	0	0

Status Register							
7	6	5	4	3	2	1	0
BSY	RDY	DF	DSC	DRQ	COR	IDX	ERR
0	V	0	V	-	0	-	V

Figure 60. Idle Immediate Command (E1h/95h)

The Idle Immediate command causes the device to enter Idle mode.

The device is spun up to operating speed. If the device is already spinning, the spin up sequence is not executed.

During Idle mode the device is spinning and ready to respond to host commands immediately.

The Idle Immediate command will not affect to auto power down timeout parameter.

## 12.9 Initialize Device Parameters (91h)

Command Block Output Registers							
Register	7	6	5	4	3	2	1 0
Data	-	-	-	-	-	-	-
Feature	-	-	-	-	-	-	-
Sector Count	V	V	V	V	V	V	V
Sector Number	-	-	-	-	-	-	-
Cylinder Low	-	-	-	-	-	-	-
Cylinder High	-	-	-	-	-	-	-
Device/Head	1	-	1	D	H	H	H
Command	1	0	0	1	0	0	0

Command Block Input Registers							
Register	7	6	5	4	3	2	1 0
Data	-	-	-	-	-	-	-
Error	-	-	-	-	-	-	-
Sector Count	-	-	-	-	-	-	-
Sector Number	-	-	-	-	-	-	-
Cylinder Low	-	-	-	-	-	-	-
Cylinder High	-	-	-	-	-	-	-
Device/Head	-	-	-	-	-	-	-
Status	...See Below...						

Error Register							
7	6	5	4	3	2	1	0
BBK	UNC	0	IDN	0	ABT	T0N	AMN
0	0	0	0	0	V	0	0

Status Register							
7	6	5	4	3	2	1	0
BSY	RDY	DF	DSC	DRQ	COR	IDX	ERR
0	0	0	-	-	0	-	V

Figure 61. Initialize Device Parameters Command (91h)

Initialize Device Parameters command enables the host to set the number of sectors per track and the number of heads minus 1, per cylinder. Words 54-58 in Identify Device information reflects these parameters.

The parameters remain in effect until following events:

- Another Initialize Device Parameters command is received.
- The device is powered off.
- Hard reset is occurred.
- Soft reset is occurred and the Set Feature option of CCh is set instead of 66h.

### Output Parameters To The Device

**Sector Count** The number of sectors per track. 0 does not mean there are 256 sectors per track, but there is no sector per track.

**H** The number of heads minus 1 per cylinder. The minimum is 0 and the maximum is 15.

**Note:** The following condition needs to be satisfied to avoid invalid number of cylinder beyond FFFFh, which will cause performance degradation of the drive.

$$(\text{Total customer usable data sectors}) / ((\text{Sector Count}) * (\text{H} + 1)) < \text{FFFFh}$$

The total customer usable data sectors are indicated at 3.1, “Logical Drive Format” on page 9, and related description is at 10.3.1, “Logical CHS Addressing Mode” on page 57.

## 12.10 Read Buffer (E4h)

Command Block Output Registers								
Register	7	6	5	4	3	2	1	0
Data	-	-	-	-	-	-	-	-
Feature	-	-	-	-	-	-	-	-
Sector Count	-	-	-	-	-	-	-	-
Sector Number	-	-	-	-	-	-	-	-
Cylinder Low	-	-	-	-	-	-	-	-
Cylinder High	-	-	-	-	-	-	-	-
Device/Head	1	-	1	D	-	-	-	-
Command	1	1	1	0	0	1	0	0

Command Block Input Registers								
Register	7	6	5	4	3	2	1	0
Data	-	-	-	-	-	-	-	-
Error	...See Below...							
Sector Count	-	-	-	-	-	-	-	-
Sector Number	-	-	-	-	-	-	-	-
Cylinder Low	-	-	-	-	-	-	-	-
Cylinder High	-	-	-	-	-	-	-	-
Device/Head	-	-	-	-	-	-	-	-
Status	...See Below...							

Error Register							
7	6	5	4	3	2	1	0
BBK	UNC	0	IDN	0	ABT	T0N	AMN
0	0	0	0	0	V	0	0

Status Register							
7	6	5	4	3	2	1	0
BSY	RDY	DF	DSC	DRQ	COR	IDX	ERR
0	V	0	-	-	0	-	V

Figure 62. Read Buffer Command (E4h)

The Read Buffer command transfers a sector of data from the sector buffer of device to the host.

The sector is transferred through the Data Register 16 bits at a time.

The sector transferred will be from the same part of the buffer written to by the last Write Buffer command. The contents of the sector may be different if any reads or writes have occurred since the Write Buffer command was issued.

## 12.11 Read DMA (C8h/C9h)

Command Block Output Registers								
Register	7	6	5	4	3	2	1	0
Data	-	-	-	-	-	-	-	-
Feature	-	-	-	-	-	-	-	-
Sector Count	V	V	V	V	V	V	V	V
Sector Number	V	V	V	V	V	V	V	V
Cylinder Low	V	V	V	V	V	V	V	V
Cylinder High	V	V	V	V	V	V	V	V
Device/Head	1	L	1	D	H	H	H	H
Command	1	1	0	0	1	0	0	R

Command Block Input Registers								
Register	7	6	5	4	3	2	1	0
Data	-	-	-	-	-	-	-	-
Error	...See Below...							
Sector Count	V	V	V	V	V	V	V	V
Sector Number	V	V	V	V	V	V	V	V
Cylinder Low	V	V	V	V	V	V	V	V
Cylinder High	V	V	V	V	V	V	V	V
Device/Head	-	-	-	-	H	H	H	H
Status	...See Below...							

Error Register							
7	6	5	4	3	2	1	0
BBK	UNC	0	IDN	0	ABT	T0N	AMN
V	0	0	V	0	V	0	V

Status Register							
7	6	5	4	3	2	1	0
BSY	RDY	DF	DSC	DRQ	COR	IDX	ERR
0	V	0	V	-	0	-	V

Figure 63. Read DMA Command (C8h/C9h)

The Read DMA command reads one or more sectors of data from disk media, then transfers the data from the device to the host.

The sectors are transferred through the Data Register 16 bits at a time.

The host initializes a slave-DMA channel prior to issuing the command. The data transfers are qualified by DMARQ and are performed by the slave-DMA channel. The device issues only one interrupt per command to indicate that data transfer has terminated and status is available.

If an uncorrectable error occurs, the read will be terminated at the failing sector.

### Output Parameters To The Device

**Sector Count** The number of continuous sectors to be transferred. If zero is specified, then 256 sectors will be transferred.

**Sector Number** The sector number of the first sector to be transferred. (L=0)  
In LBA mode, this register specifies LBA address bits 0 - 7 to be transferred. (L=1)

**Cylinder High/Low** The cylinder number of the first sector to be transferred. (L=0)  
In LBA mode, this register specifies LBA address bits 8 - 15 (Low) 16 - 23 (High) to be transferred. (L=1)

- H** The head number of the first sector to be transferred. (L=0)  
In LBA mode, this register specifies LBA bits 24-27 to be transferred. (L=1)
- R** The retry bit. If set to one, then retries are disabled.

**Input Parameters From The Device**

- Sector Count** The number of requested sectors not transferred. This will be zero, unless an unrecoverable error occurs.
- Sector Number** The sector number of the last transferred sector. (L=0)  
In LBA mode, this register contains current LBA bits 0 - 7. (L=1)
- Cylinder High/Low** The cylinder number of the last transferred sector. (L=0)  
In LBA mode, this register contains current LBA bits 8 - 15 (Low), 16 - 23 (High). (L=1)
- H** The head number of the sector to be transferred. (L=0)  
In LBA mode, this register contains current LBA bits 24 - 27. (L=1)

## 12.12 Read Long (22h/23h)

Command Block Output Registers								
Register	7	6	5	4	3	2	1	0
Data	-	-	-	-	-	-	-	-
Feature	-	-	-	-	-	-	-	-
Sector Count	0	0	0	0	0	0	0	1
Sector Number	V	V	V	V	V	V	V	V
Cylinder Low	V	V	V	V	V	V	V	V
Cylinder High	V	V	V	V	V	V	V	V
Device/Head	1	L	1	D	H	H	H	H
Command	0	0	1	0	0	0	1	R

Command Block Input Registers								
Register	7	6	5	4	3	2	1	0
Data	-	-	-	-	-	-	-	-
Error	...See Below...							
Sector Count	-	-	-	-	-	-	-	V
Sector Number	V	V	V	V	V	V	V	V
Cylinder Low	V	V	V	V	V	V	V	V
Cylinder High	V	V	V	V	V	V	V	V
Device/Head	-	-	-	-	H	H	H	H
Status	...See Below...							

Error Register							
7	6	5	4	3	2	1	0
BBK	UNC	0	IDN	0	ABT	T0N	AMN
0	0	0	V	0	V	0	V

Status Register							
7	6	5	4	3	2	1	0
BSY	RDY	DF	DSC	DRQ	COR	IDX	ERR
0	V	0	V	-	0	-	V

Figure 64. Read Long Command (22h/23h)

The Read Long command read the designated one sector of data and the ECC bytes from disk media, then transfers the data and ECC bytes from the device to the host.

After 512 bytes of data have been transferred, the device will keep setting DRQ=1 to indicate that the device is ready to transfer the ECC bytes to the host. The data is transferred 16 bits at a time, and the ECC bytes are transferred 8 bits at a time. The number of ECC bytes are 4 or 20 according to setting of Set Feature option. The default setting is 4 bytes of ECC data.

The command makes a single attempt to read the data and does not check the data using ECC, whatever is read is returned to the host.

### Output Parameters To The Device

**Sector Count** The number of continuous sectors to be transferred. The Sector Count must be set to one.

**Sector Number** The sector number of the sector to be transferred. (L=0)  
In LBA mode, this register contains LBA bits 0 - 7. (L=1)

**Cylinder High/Low** The cylinder number of the sector to be transferred. (L=0)  
In LBA mode, this register contains LBA bits 8 - 15 (Low), 16 - 23 (High). (L=1)

- H** The head number of the sector to be transferred. (L=0)  
In LBA mode, this register contains LBA bits 24-27. (L=1)
- R** The retry bit. If set to one, then retries are disabled.

**Input Parameters From The Device**

- Sector Count** The number of requested sectors not transferred.
- Sector Number** The sector number of the transferred sector. (L=0)  
In LBA mode, this register contains current LBA bits 0 - 7. (L=1)
- Cylinder High/Low** The cylinder number of the transferred sector. (L=0)  
In LBA mode, this register contains current LBA bits 8 - 15 (Low), 16 - 23 (High). (L=1)
- H** The head number of the transferred sector. (L=0)  
In LBA mode, this register contains current LBA bits 24-27. (L=1)

It should be noted that the device internally uses 20 bytes of ECC data on all data written or read from the disk. The 4 byte mode of operation is provided via an emulation. It is recommended that for testing the effectiveness and integrity of the devices ECC functions that the 20 byte ECC mode should be used.

## 12.13 Read Multiple (C4h)

Command Block Output Registers							
Register	7	6	5	4	3	2	1 0
Data	-	-	-	-	-	-	-
Feature	-	-	-	-	-	-	-
Sector Count	V	V	V	V	V	V	V
Sector Number	V	V	V	V	V	V	V
Cylinder Low	V	V	V	V	V	V	V
Cylinder High	V	V	V	V	V	V	V
Device/Head	1	L	1	D	H	H	H
Command	1	1	0	0	0	1	0

Command Block Input Registers							
Register	7	6	5	4	3	2	1 0
Data	-	-	-	-	-	-	-
Error	...See Below...						
Sector Count	V	V	V	V	V	V	V
Sector Number	V	V	V	V	V	V	V
Cylinder Low	V	V	V	V	V	V	V
Cylinder High	V	V	V	V	V	V	V
Device/Head	-	-	-	-	H	H	H
Status	...See Below...						

Error Register							
7	6	5	4	3	2	1	0
BBK	UNC	0	IDN	0	ABT	T0N	AMN
V	V	0	V	0	V	0	V

Status Register							
7	6	5	4	3	2	1	0
BSY	RDY	DF	DSC	DRQ	COR	IDX	ERR
0	V	0	V	-	0	-	V

Figure 65. Read Multiple Command (C4h)

The Read Multiple command reads one or more sectors of data from disk media, then transfers the data from the device to the host.

The sectors are transferred through the Data Register 16 bits at a time. Command execution is identical to the Read Sectors command except that an interrupt is generated for each block (as defined by the Set Multiple command) instead of for each sector.

### Output Parameters To The Device

**Sector Count** The number of continuous sectors to be transferred. If zero is specified, then 256 sectors will be transferred.

**Sector Number** The sector number of the first sector to be transferred. (L=0)

In LBA mode, this register contains LBA bits 0 - 7. (L=1)

**Cylinder High/Low** The cylinder number of the first sector to be transferred. (L=0)

In LBA mode, this register contains LBA bits 8 - 15 (Low), 16 - 23 (High). (L=1)

**H** The head number of the first sector to be transferred. (L=0)

In LBA mode, this register contains LBA bits 24 - 27. (L=1)

### **Input Parameters From The Device**

<b>Sector Count</b>	The number of requested sectors not transferred. This will be zero, unless an unrecoverable error occurs.
<b>Sector Number</b>	The sector number of the last transferred sector. (L=0) In LBA mode, this register contains current LBA bits 0 - 7. (L=1)
<b>Cylinder High/Low</b>	The cylinder number of the last transferred sector. (L=0) In LBA mode, this register contains current LBA bits 8 - 15 (Low), 16 - 23 (High). (L=1)
<b>H</b>	The head number of the last transferred sector. (L=0) In LBA mode, this register contains current LBA bits 24 - 27. (L=1)

## 12.14 Read Native Max LBA/CYL (F8h: Vendor Specific)

Command Block Output Registers							
Register	7	6	5	4	3	2	1 0
Data	-	-	-	-	-	-	-
Feature	-	-	-	-	-	-	-
Sector Count	-	-	-	-	-	-	-
Sector Number	-	-	-	-	-	-	-
Cylinder Low	-	-	-	-	-	-	-
Cylinder High	-	-	-	-	-	-	-
Device/Head	1	L	1	D	-	-	-
Command	1	1	1	1	1	0	0 0

Command Block Input Registers							
Register	7	6	5	4	3	2	1 0
Data	-	-	-	-	-	-	-
Error	...See Below...						
Sector Count	-	-	-	-	-	-	-
Sector Number	V	V	V	V	V	V	V
Cylinder Low	V	V	V	V	V	V	V
Cylinder High	V	V	V	V	V	V	V
Device/Head	-	-	-	-	H	H	H
Status	...See Below...						

Error Register							
7	6	5	4	3	2	1	0
BBK	UNC	0	IDN	0	ABT	T0N	AMN
0	0	0	0	0	V	0	0

Status Register							
7	6	5	4	3	2	1	0
BSY	RDY	DF	DSC	DRQ	COR	IDX	ERR
0	V	0	-	-	0	-	V

Figure 66. Read Native Max LBA/CYL (F8h)

This command returns the native number of LBA/CYL of HDD which is not effected by Set Max LBA/CYL command.

### Output Parameters To The Device

- L** LBA mode. Indicates the addressing mode. L=0 specifies CHS mode and L=1 does LBA addressing mode.
- D** The device number bit. Indicates that the device number bit of the Device/Head Register should be specified. D=0 selects the master device and D=1 selects the slave device. should be specified.
- Indicates that the bit is not used.

### Input Parameters From The Device

- Sector Number** In LBA mode, this register contains native number of LBA bits 0 - 7. (L=1)  
In CHS mode, this register contains native number of sector. (L=0)
- Cylinder High/Low** In LBA mode, this register contains native number of LBA bits 8 - 15 (Low), 16 - 23 (High). (L=1)  
In CHS mode, this register contains native number of cylinder. (L=0)
- H** In LBA mode, this register contains native number of LBA bits 24 - 27. (L=1)  
In CHS mode, this register contains native number of head minus 1. (L=0)

- V** Valid. Indicates that the bit is part of an input parameter and will be set to 0 or 1 by the device.
- Indicates that the bit is not used.

## 12.15 Read Sectors (20h/21h)

Command Block Output Registers								
Register	7	6	5	4	3	2	1	0
Data	-	-	-	-	-	-	-	-
Feature	-	-	-	-	-	-	-	-
Sector Count	V	V	V	V	V	V	V	V
Sector Number	V	V	V	V	V	V	V	V
Cylinder Low	V	V	V	V	V	V	V	V
Cylinder High	V	V	V	V	V	V	V	V
Device/Head	1	L	1	D	H	H	H	H
Command	0	0	1	0	0	0	0	R

Command Block Input Registers								
Register	7	6	5	4	3	2	1	0
Data	-	-	-	-	-	-	-	-
Error	...See Below...							
Sector Count	V	V	V	V	V	V	V	V
Sector Number	V	V	V	V	V	V	V	V
Cylinder Low	V	V	V	V	V	V	V	V
Cylinder High	V	V	V	V	V	V	V	V
Device/Head	-	-	-	-	H	H	H	H
Status	...See Below...							

Error Register							
7	6	5	4	3	2	1	0
BBK	UNC	0	IDN	0	ABT	T0N	AMN
V	V	0	V	0	V	0	V

Status Register							
7	6	5	4	3	2	1	0
BSY	RDY	DF	DSC	DRQ	COR	IDX	ERR
0	V	0	V	-	0	-	V

Figure 67. Read Sectors Command (20h/21h)

The Read Sectors command reads one or more sectors of data from disk media, then transfers the data from the device to the host.

The sectors are transferred through the Data Register 16 bits at a time.

If an uncorrectable error occurs, the read will be terminated at the failing sector.

### Output Parameters To The Device

**Sector Count** The number of continuous sectors to be transferred. If zero is specified, then 256 sectors will be transferred.

**Sector Number** The sector number of the first sector to be transferred. (L=0)

In LBA mode, this register contains LBA bits 0 - 7. (L=1)

**Cylinder High/Low** The cylinder number of the first sector to be transferred. (L=0)

In LBA mode, this register contains LBA bits 8 - 15 (Low), 16 - 23 (High). (L=1)

**H** The head number of the first sector to be transferred. (L=0)

In LBA mode, this register contains LBA bits 24 - 27. (L=1)

**R** The retry bit. If set to one, then retries are disabled.

### **Input Parameters From The Device**

<b>Sector Count</b>	The number of requested sectors not transferred. This will be zero, unless an unrecoverable error occurs.
<b>Sector Number</b>	The sector number of the last transferred sector. (L=0) In LBA mode, this register contains current LBA bits 0 - 7. (L=1)
<b>Cylinder High/Low</b>	The cylinder number of the last transferred sector. (L=0) In LBA mode, this register contains current LBA bits 8 - 15 (Low), 16 - 23 (High). (L=1)
<b>H</b>	The head number of the last transferred sector. (L=0) In LBA mode, this register contains current LBA bits 24 - 27. (L=1)

## 12.16 Read Verify Sectors (40h/41h)

Command Block Output Registers							
Register	7	6	5	4	3	2	1 0
Data	-	-	-	-	-	-	-
Feature	-	-	-	-	-	-	-
Sector Count	V	V	V	V	V	V	V
Sector Number	V	V	V	V	V	V	V
Cylinder Low	V	V	V	V	V	V	V
Cylinder High	V	V	V	V	V	V	V
Device/Head	1	L	1	D	H	H	H
Command	0	0	1	0	0	0	R

Command Block Input Registers							
Register	7	6	5	4	3	2	1 0
Data	-	-	-	-	-	-	-
Error	...See Below...						
Sector Count	V	V	V	V	V	V	V
Sector Number	V	V	V	V	V	V	V
Cylinder Low	V	V	V	V	V	V	V
Cylinder High	V	V	V	V	V	V	V
Device/Head	-	-	-	-	H	H	H
Status	...See Below...						

Error Register							
7	6	5	4	3	2	1	0
BBK	UNC	0	IDN	0	ABT	T0N	AMN
V	V	0	V	0	V	0	V

Status Register							
7	6	5	4	3	2	1	0
BSY	RDY	DF	DSC	DRQ	COR	IDX	ERR
0	V	0	V	-	0	-	V

Figure 68. Read Verify Sectors Command (40h/41h)

The Read Verify Sectors verifies one or more sectors on the device. No data is transferred to the host.

The difference of Read Sectors command and Read Verify Sectors command is whether the data is transferred to the host or not.

If an uncorrectable error occurs, the read verify will be terminated at the failing sector.

### Output Parameters To The Device

**Sector Count** The number of continuous sectors to be verified. If zero is specified, then 256 sectors will be verified.

**Sector Number** The sector number of the first sector to be transferred. (L=0)  
In LBA mode, this register contains LBA bits 0 - 7. (L=1)

**Cylinder High/Low** The cylinder number of the first sector to be transferred. (L=0)  
In LBA mode, this register contains LBA bits 8 - 15 (Low), 16 - 23 (High). (L=1)

**H** The head number of the first sector to be transferred. (L=0)  
In LBA mode, this register contains LBA bits 24 - 27. (L=1)

**R** The retry bit. If set to one, then retries are disabled.

### Input Parameters From The Device

<b>Sector Count</b>	The number of requested sectors not verified. This will be zero, unless an unrecoverable error occurs.
<b>Sector Number</b>	The sector number of the last transferred sector. (L=0) In LBA mode, this register contains current LBA bits 0 - 7. (L=1)
<b>Cylinder High/Low</b>	The cylinder number of the last transferred sector. (L=0) In LBA mode, this register contains current LBA bits 8 - 15 (Low), 16 - 23 (High). (L=1)
<b>H</b>	The head number of the last transferred sector. (L=0) In LBA mode, this register contains current LBA bits 24 - 27. (L=1)

## 12.17 Recalibrate (1xh)

Command Block Output Registers								
Register	7	6	5	4	3	2	1	0
Data	-	-	-	-	-	-	-	-
Feature	-	-	-	-	-	-	-	-
Sector Count	-	-	-	-	-	-	-	-
Sector Number	-	-	-	-	-	-	-	-
Cylinder Low	-	-	-	-	-	-	-	-
Cylinder High	-	-	-	-	-	-	-	-
Device/Head	1	-	1	D	-	-	-	-
Command	0	0	0	1	-	-	-	-

Command Block Input Registers								
Register	7	6	5	4	3	2	1	0
Data	-	-	-	-	-	-	-	-
Error	...See Below...							
Sector Count	-	-	-	-	-	-	-	-
Sector Number	-	-	-	-	-	-	-	-
Cylinder Low	-	-	-	-	-	-	-	-
Cylinder High	-	-	-	-	-	-	-	-
Device/Head	-	-	-	-	-	-	-	-
Status	...See Below...							

Error Register							
7	6	5	4	3	2	1	0
BBK	UNC	0	IDN	0	ABT	T0N	AMN
0	0	0	0	0	V	V	0

Status Register							
7	6	5	4	3	2	1	0
BSY	RDY	DF	DSC	DRQ	COR	IDX	ERR
0	V	0	V	-	0	-	V

Figure 69. Recalibrate Command (1xh)

The Recalibrate command moves the read/write heads from anywhere on the disk to cylinder 0.

If the device cannot reach cylinder 0, T0N (Track 0 Not Found) will be set in the Error Register.

## 12.18 Security Disable Password (F6h)

Command Block Output Registers								
Register	7	6	5	4	3	2	1	0
Data	-	-	-	-	-	-	-	-
Feature	-	-	-	-	-	-	-	-
Sector Count	-	-	-	-	-	-	-	-
Sector Number	-	-	-	-	-	-	-	-
Cylinder Low	-	-	-	-	-	-	-	-
Cylinder High	-	-	-	-	-	-	-	-
Device/Head	1	-	1	D	-	-	-	-
Command	1	1	1	1	0	1	1	0

Command Block Input Registers								
Register	7	6	5	4	3	2	1	0
Data	-	-	-	-	-	-	-	-
Error	...See Below...							
Sector Count	-	-	-	-	-	-	-	-
Sector Number	-	-	-	-	-	-	-	-
Cylinder Low	-	-	-	-	-	-	-	-
Cylinder High	-	-	-	-	-	-	-	-
Device/Head	-	-	-	-	-	-	-	-
Status	...See Below...							

Error Register							
7	6	5	4	3	2	1	0
BBK	UNC	0	IDN	0	ABT	T0N	AMN
0	0	0	0	0	V	0	0

Status Register							
7	6	5	4	3	2	1	0
BSY	RDY	DF	DSC	DRQ	COR	IDX	ERR
0	V	0	V	-	0	-	V

Figure 70. Security Disable Password Command (F6h)

The Security Disable Password command disables the security mode feature ( device lock function).

The Security Disable Password command requests a transfer of a single sector of data from the host including information specified in Figure 71. Then the device checks the transferred password. If the User Password or Master Password matches the given password the device disables the security mode feature (device lock function). This command does not change the Master Password which may be re-activated later by setting User Password. This command should be executed in device unlock mode.

Word	Description
00	Control word bit 0 : Identifier (1- Master, 0- User) bit 1-15 : Reserved
01-16	Password ( 32 bytes )
17-255	Reserved

Figure 71. Password Information for Security Disable Password command

The device will compare the password sent from this host with that specified in the control word.

**Identifier** Zero indicates that the device should check the supplied password against the user password stored internally. One indicates that the device should check the given password against the master password stored internally.

## 12.19 Security Erase Prepare (F3h)

Command Block Output Registers								
Register	7	6	5	4	3	2	1	0
Data	-	-	-	-	-	-	-	-
Feature	-	-	-	-	-	-	-	-
Sector Count	-	-	-	-	-	-	-	-
Sector Number	-	-	-	-	-	-	-	-
Cylinder Low	-	-	-	-	-	-	-	-
Cylinder High	-	-	-	-	-	-	-	-
Device/Head	1	-	1	D	-	-	-	-
Command	1	1	1	1	0	0	1	1

Command Block Input Registers								
Register	7	6	5	4	3	2	1	0
Data	-	-	-	-	-	-	-	-
Error	...See Below...							
Sector Count	-	-	-	-	-	-	-	-
Sector Number	-	-	-	-	-	-	-	-
Cylinder Low	-	-	-	-	-	-	-	-
Cylinder High	-	-	-	-	-	-	-	-
Device/Head	-	-	-	-	-	-	-	-
Status	...See Below...							

Error Register							
7	6	5	4	3	2	1	0
BBK	UNC	0	IDN	0	ABT	T0N	AMN
0	0	0	0	0	V	0	0

Status Register							
7	6	5	4	3	2	1	0
BSY	RDY	DF	DSC	DRQ	COR	IDX	ERR
0	V	0	V	-	0	-	V

Figure 72. Security Erase Prepare Command (F3h)

The Security Erase Prepare Command must be issued immediately before the Security Erase Unit Command to enable device erasing and unlocking.

The Security Erase Prepare Command must be issued immediately before the Format Unit Command. This command is to prevent accidental erasure of the device.

This command does not request to data transfer.

## 12.20 Security Erase Unit (F4h)

Command Block Output Registers								
Register	7	6	5	4	3	2	1	0
Data	-	-	-	-	-	-	-	-
Feature	-	-	-	-	-	-	-	-
Sector Count	-	-	-	-	-	-	-	-
Sector Number	-	-	-	-	-	-	-	-
Cylinder Low	-	-	-	-	-	-	-	-
Cylinder High	-	-	-	-	-	-	-	-
Device/Head	1	-	1	D	-	-	-	-
Command	1	1	1	1	0	1	0	0

Command Block Input Registers								
Register	7	6	5	4	3	2	1	0
Data	-	-	-	-	-	-	-	-
Error	...See Below...							
Sector Count	-	-	-	-	-	-	-	-
Sector Number	-	-	-	-	-	-	-	-
Cylinder Low	-	-	-	-	-	-	-	-
Cylinder High	-	-	-	-	-	-	-	-
Device/Head	-	-	-	-	-	-	-	-
Status	...See Below...							

Error Register							
7	6	5	4	3	2	1	0
BBK	UNC	0	IDN	0	ABT	T0N	AMN
0	0	0	V	0	V	0	0

Status Register							
7	6	5	4	3	2	1	0
BSY	RDY	DF	DSC	DRQ	COR	IDX	ERR
0	V	0	V	-	0	-	V

Figure 73. Security Erase Unit Command (F4h)

The Security Erase Unit command initializes all user data sectors, then disables the device lock function.

Note that the Format Unit command initializes from LBA 0 to Native MAX LBA. Host MAX LBA set by Initialize Drive Parameter or Set MAX LBA/CYL command is ignored. So the protected area by Set MAX LBA/CYL command is also initialized.

This command requests to transfer a single sector data from the host including information specified in Figure 74.

If the password does not match then the device rejects the command with an Aborted error.

Word	Description
00	Control word bit 0 : Identifier (1- Master, 0- User) bit 1-15 : Reserved
01-16	Password ( 32 bytes )
17-255	Reserved

Figure 74. Erase Unit information

**Identifier**                    Zero indicates that the device should check the supplied password against the user password stored internally. One indicates that the device should check the given password against the master password stored internally.

The Security Erase Unit command erases all user data and disables the security mode feature (device lock function). So after completing this command, all user data will be initialized to zero with write operation. At this time, the initialized sector of data is not verified with read operation whether the sector of data is initialized correctly. And, the defective sector information and the reassigned sector information for the device are not updated. The security erase prepare command should be completed immediately prior to the Security Erase Unit command. If the device receives an Security Erase Unit command without a prior Security Erase Prepare command the device aborts the security erase unit command.

This command disables the security mode feature (device lock function), however the master password is still stored internally within the device and may be re-activated later when a new user password is set. If you execute this command on disabling the security mode feature (device lock function), the password sent by the host is NOT compared with the password stored in the device for both the Master Password and the User Password, and then the device only erases all user data.

The execution time of this command is shown below.

**DMCA-21440**                    about 6min.50sec.

**DMCA-21080**                    about 5min.10sec.

## 12.21 Security Freeze Lock (F5h)

Command Block Output Registers								
Register	7	6	5	4	3	2	1	0
Data	-	-	-	-	-	-	-	-
Feature	-	-	-	-	-	-	-	-
Sector Count	-	-	-	-	-	-	-	-
Sector Number	-	-	-	-	-	-	-	-
Cylinder Low	-	-	-	-	-	-	-	-
Cylinder High	-	-	-	-	-	-	-	-
Device/Head	1	-	1	D	-	-	-	-
Command	1	1	1	1	0	1	0	1

Command Block Input Registers								
Register	7	6	5	4	3	2	1	0
Data	-	-	-	-	-	-	-	-
Error	...See Below...							
Sector Count	-	-	-	-	-	-	-	-
Sector Number	-	-	-	-	-	-	-	-
Cylinder Low	-	-	-	-	-	-	-	-
Cylinder High	-	-	-	-	-	-	-	-
Device/Head	-	-	-	-	-	-	-	-
Status	...See Below...							

Error Register							
7	6	5	4	3	2	1	0
BBK	UNC	0	IDN	0	ABT	T0N	AMN
0	0	0	0	0	V	0	0

Status Register							
7	6	5	4	3	2	1	0
BSY	RDY	DF	DSC	DRQ	COR	IDX	ERR
0	V	0	-	-	0	-	V

Figure 75. Security Freeze Lock Command (F5h)

The Security Freeze Lock Command allows the device to enter frozen mode immediately.

After this command is completed, the command which updates Security Mode Feature (Device Lock Function) is rejected.

Frozen mode is quit only by Power off.

Following commands are rejected when the device is in frozen mode. For detail, refer to Figure 44 on page 67.

- Security Set Password
- Security Unlock
- Security Disable Password
- Security Erase Unit

## 12.22 Security Set Password (F1h)

Command Block Output Registers								
Register	7	6	5	4	3	2	1	0
Data	-	-	-	-	-	-	-	-
Feature	-	-	-	-	-	-	-	-
Sector Count	-	-	-	-	-	-	-	-
Sector Number	-	-	-	-	-	-	-	-
Cylinder Low	-	-	-	-	-	-	-	-
Cylinder High	-	-	-	-	-	-	-	-
Device/Head	1	-	1	D	-	-	-	-
Command	1	1	1	1	0	0	0	1

Command Block Input Registers								
Register	7	6	5	4	3	2	1	0
Data	-	-	-	-	-	-	-	-
Error	...See Below...							
Sector Count	-	-	-	-	-	-	-	-
Sector Number	-	-	-	-	-	-	-	-
Cylinder Low	-	-	-	-	-	-	-	-
Cylinder High	-	-	-	-	-	-	-	-
Device/Head	-	-	-	-	-	-	-	-
Status	...See Below...							

Error Register							
7	6	5	4	3	2	1	0
BBK	UNC	0	IDN	0	ABT	T0N	AMN
0	0	0	0	0	V	0	0

Status Register							
7	6	5	4	3	2	1	0
BSY	RDY	DF	DSC	DRQ	COR	IDX	ERR
0	V	0	-	-	0	-	V

Figure 76. Security Set Password Command (F1h)

The Security Set Password command enables security mode feature (device lock function), and sets the master password or the user password.

The security mode feature (device lock function) is enabled by this command, the device is not locked immediately. And the device is locked after next power on reset or hard reset. When the MASTER password is set by this command, the master password is registered internally, but the device is NOT locked after next power on reset or hard reset.

This command requests a transfer of a single sector of data from the host including the information specified in Figure 77 on page 117.

The data transferred controls the function of this command.

Word	Description
00	Control word bit 0 : Identifier (1- Master, 0- User) bit 1-7 : Reserved bit 8 : Security level (1- Maximum, 0- High) bit 9-15 : Reserved
01-16	Password (32 byte)
17-255	Reserved

Figure 77. Security Set Password Information

**Identifier** Zero indicates that device regards Password as User Password. One indicates that device regards Password as Master Password.

**Security Level** Zero indicates High level, one indicates Maximum level. If the host sets High level and the password is forgotten, then the Master Password can be used to unlock the device. If the host sets Maximum level and the user password is forgotten, only an Security Erase Prepare/Security Unit command can unlock the device and all data will be lost.

**Password** The text of the password - all 32 bytes are always significant.

The setting of the Identifier and Security level bits interact as follows.

**Identifier=User / Security level = High** The password supplied with the command will be saved as the new user password. The security mode feature (lock function) will be enabled from the next power on. The file may then be unlocked by either the user password or the previously set master password.

**Identifier=Master / Security level = High** This combination will set a master password but will NOT enable the security mode feature (lock function).

**Identifier=User / Security level = Maximum** The password supplied with the command will be saved as the new user password. The security mode feature (lock function) will be enabled from the next power on. The file may then be unlocked by only the user password. The master password previously set is still stored in the file but may NOT be used to unlock the device.

**Identifier=Master / Security level = Maximum** This combination will set a master password but will NOT enable the security mode feature (lock function).

## 12.23 Security Unlock (F2h)

Command Block Output Registers								
Register	7	6	5	4	3	2	1	0
Data	-	-	-	-	-	-	-	-
Feature	-	-	-	-	-	-	-	-
Sector Count	-	-	-	-	-	-	-	-
Sector Number	-	-	-	-	-	-	-	-
Cylinder Low	-	-	-	-	-	-	-	-
Cylinder High	-	-	-	-	-	-	-	-
Device/Head	1	-	1	D	-	-	-	-
Command	1	1	1	1	0	0	1	0

Command Block Input Registers								
Register	7	6	5	4	3	2	1	0
Data	-	-	-	-	-	-	-	-
Error	...See Below...							
Sector Count	-	-	-	-	-	-	-	-
Sector Number	-	-	-	-	-	-	-	-
Cylinder Low	-	-	-	-	-	-	-	-
Cylinder High	-	-	-	-	-	-	-	-
Device/Head	-	-	-	-	-	-	-	-
Status	...See Below...							

Error Register							
7	6	5	4	3	2	1	0
BBK	UNC	0	IDN	0	ABT	T0N	AMN
0	V	0	0	0	V	0	0

Status Register							
7	6	5	4	3	2	1	0
BSY	RDY	DF	DSC	DRQ	COR	IDX	ERR
0	V	0	-	-	0	-	V

Figure 78. Security Unlock Command (F2h)

This command unlocks the password and cause the device to enter device unlock mode. If power on reset or hard reset is done without executing Security Disable Password command after this command is completed, the device will be in device lock mode. The password has not been changed yet.

The Security Unlock command requests to transfer a single sector of data from the host including information specified in Figure 79 on page 119.

If the Identifier bit is set to master and the file is in high security mode then the password supplied will be compared with the stored master password. If the file is in maximum security mode then the security unlock will be rejected.

If the Identifier bit is set to user then the file compares the supplied password with the stored user password.

If the password compare fails then the device returns an abort error to the host and decrements the unlock attempt counter. This counter is initially set to 5 and is decremented for each password mismatch. When this counter reaches zero then all password protected commands are rejected until a hard reset or a power off.

Word	Description
00	Control word bit 0 : Identifier (1- Master, 0- User) bit 1-15 : Reserved
01-16	Password ( 32 bytes )
17-255	Reserved

Figure 79. Security Unlock Information

**Identifier**                      Zero indicates that device regards Password as User Password. One indicates that device regards Password as Master Password.

The user can detect if the attempt to unlock the device has failed due to a mismatched password as this is the only reason that an abort error will be returned by the file AFTER the password information has been sent to the device. If an abort error is returned by the device BEFORE the password data has been sent to the file then another problem exists.

## 12.24 Seek (7xh)

Command Block Output Registers								
Register	7	6	5	4	3	2	1	0
Data	-	-	-	-	-	-	-	-
Feature	-	-	-	-	-	-	-	-
Sector Count	-	-	-	-	-	-	-	-
Sector Number	V	V	V	V	V	V	V	V
Cylinder Low	V	V	V	V	V	V	V	V
Cylinder High	V	V	V	V	V	V	V	V
Device/Head	1	L	1	D	H	H	H	H
Command	0	1	1	1	-	-	-	-

Command Block Input Registers								
Register	7	6	5	4	3	2	1	0
Data	-	-	-	-	-	-	-	-
Error	...See Below...							
Sector Count	-	-	-	-	-	-	-	-
Sector Number	V	V	V	V	V	V	V	V
Cylinder Low	V	V	V	V	V	V	V	V
Cylinder High	V	V	V	V	V	V	V	V
Device/Head	-	-	-	-	H	H	H	H
Status	...See Below...							

Error Register							
7	6	5	4	3	2	1	0
BBK	UNC	0	IDN	0	ABT	T0N	AMN
0	0	0	V	0	V	0	0

Status Register							
7	6	5	4	3	2	1	0
BSY	RDY	DF	DSC	DRQ	COR	IDX	ERR
0	V	0	V	-	0	-	V

Figure 80. Seek Command (7xh)

The Seek command initiates a seek to the designated track and selects the designated head. The device need not be formatted for a seek to execute properly.

### Output Parameters To The Device

**Sector Number** In LBA mode, this register specifies LBA address bits 0 - 7 for seek. (L=1)

**Cylinder High/Low** The cylinder number of the seek.

In LBA mode, this register specifies LBA address bits 8 - 15 (Low), 16 - 23 (High) for seek. (L=1)

**H** The head number of the seek.

In LBA mode, this register specifies LBA address bits 24 - 27 for seek. (L=1)

### Input Parameters From The Device

**Sector Number** In LBA mode, this register contains current LBA bits 0 - 7. (L=1)

**Cylinder High/Low** In LBA mode, this register contains current LBA bits 8 - 15 (Low), 16 - 23 (High). (L=1)

**H** In LBA mode, this register contains current LBA bits 24 - 27. (L=1)

## 12.25 Set Features (EFh)

Command Block Output Registers							
Register	7	6	5	4	3	2	1 0
Data	-	-	-	-	-	-	-
Feature	V	V	V	V	V	V	V
Sector Count	Note.1						
Sector Number	-	-	-	-	-	-	-
Cylinder Low	-	-	-	-	-	-	-
Cylinder High	-	-	-	-	-	-	-
Device/Head	1	-	1	D	-	-	-
Command	1	1	1	0	1	1	1

Command Block Input Registers							
Register	7	6	5	4	3	2	1 0
Data	-	-	-	-	-	-	-
Error	...See Below...						
Sector Count	-	-	-	-	-	-	-
Sector Number	-	-	-	-	-	-	-
Cylinder Low	-	-	-	-	-	-	-
Cylinder High	-	-	-	-	-	-	-
Device/Head	-	-	-	-	-	-	-
Status	...See Below...						

Error Register							
7	6	5	4	3	2	1	0
BBK	UNC	0	IDN	0	ABT	T0N	AMN
0	0	0	0	0	V	0	0

Status Register							
7	6	5	4	3	2	1	0
BSY	RDY	DF	DSC	DRQ	COR	IDX	ERR
0	V	0	-	-	0	-	V

Figure 81. Set Features Command (EFh)

The Set Feature command is to establish the following parameters which affect the execution of certain features as shown in below table.

ABT will be set to 1 in the Error Register if the Feature register contains any undefined values.

### Output Parameters To The Device

<b>Feature</b>	Destination code for this command.
<b>02H</b>	Enable write cache (Warning.1)
<b>03H</b>	Set transfer mode based on value in sector count register
<b>44H</b>	22 bytes of ECC apply on Read Long/Write Long commands
<b>55H</b>	Disable read look-ahead feature
<b>66H</b>	Disable reverting to power on defaults
<b>82H</b>	Disable write cache
<b>AAH</b>	Enable read look-ahead feature
<b>BBH</b>	4 bytes of ECC apply on Read Long/Write Long commands
<b>CCH</b>	Enable reverting to power on defaults

Warning 1. Hard reset or power off must not be done in 5 seconds after write command completion when write cache is enabled.

Note 1.

When Feature register is 03h (=Set Transfer mode), the Sector Count Register specifies the transfer mechanism. The upper 5 bits define the type of transfer and the low order 3 bits encode the mode value.

PIO Default Transfer Mode	00000	000
PIO Default Transfer Mode,Disable IORDY	00000	001
PIO Flow Control Transfer Mode x	00001	nnn (nnn=000,001,010,011,100)
Single word DMA mode x	00010	nnn (nnn=000,001,010)
Multiword DMA mode x	00100	nnn (nnn=000,001,010)

Note 2.

If the number of auto reassigned sector reaches the device's reassignment capacity, the write cache function will be automatically disabled. Although the device still accepts the Set Features command with Feature register = 02h without error, but the write cache function will remains disabled. For current write cache function status, please refer to Identify Device Information(129word) by Identify Device command.

Note 3.

After power on reset or hard reset, the device is set to the following features as default.

Write cache	:	Enable
ECC bytes	:	4 bytes
Read look-ahead	:	Enable
Reverting to power on defaults	:	Disable

## 12.26 Set Max LBA/CYL (F9h: Vendor Specific)

Command Block Output Registers							
Register	7	6	5	4	3	2	1 0
Data	-	-	-	-	-	-	-
Feature	-	-	-	-	-	-	-
Sector Count	-	-	-	-	-	-	B
Sector Number	V	V	V	V	V	V	V
Cylinder Low	V	V	V	V	V	V	V
Cylinder High	V	V	V	V	V	V	V
Device/Head	1	L	1	D	H	H	H
Command	1	1	1	1	1	0	0

Command Block Input Registers							
Register	7	6	5	4	3	2	1 0
Data	-	-	-	-	-	-	-
Error	...See Below...						
Sector Count	-	-	-	-	-	-	-
Sector Number	V	V	V	V	V	V	V
Cylinder Low	V	V	V	V	V	V	V
Cylinder High	V	V	V	V	V	V	V
Device/Head	-	-	-	-	H	H	H
Status	...See Below...						

Error Register							
7	6	5	4	3	2	1	0
BBK	UNC	0	IDN	0	ABT	T0N	AMN
0	0	0	0	0	V	0	0

Status Register							
7	6	5	4	3	2	1	0
BSY	RDY	DF	DSC	DRQ	COR	IDX	ERR
0	V	0	-	-	0	-	V

Figure 82. Set Max LBA/CYL (F9h)

This command overwrites the number of LBA/CYL of HDD in a range of actual device capacity. Once device receives this command, all accesses beyond that LBA/CYL are rejected with setting ABORT bit in status register. Identify device command and Identify device DMA command returns the LBA/CYL which is set via this command as a default value.

Read Native Max LBA/CYL command should be issued and completed immediately prior to issuing Set Max LBA/CYL command. If the device receives Set Max LBA/CYL command without a prior Read Native Max LBA/CYL command, the device aborts the Set Max LBA/CYL command.

In CHS mode, Cylinder High, Cylinder Low specify the number of cylinders. The Head number of DEVICE/HEAD and Sector Number are ignored. The default value (Number of heads per track = 16, Number of sectors per head = 63) is used for that.

In LBA mode, the Head number of DEVICE/HEAD, Cylinder High, Cylinder Low and Sector Number specify the number of LBA. This number of LBA is adjusted to as follows.

$$\begin{aligned} \text{Adjusted Number of LBA} &= \text{Number of heads per track (=16)} \\ &\quad \times \text{Number of sectors per head (=63)} \\ &\quad \times \text{Number of cylinders} \end{aligned}$$

Number of cylinders is quotient of (Set number by this command)/(16 x 63). So the remainder of (Set number by this command)/(16 x 63) is cut down. In LBA mode, if the command sets the LBA that is smaller than 16 x 63, the device returns aborted error to the host. In CHS mode, if the command sets number of cylinder = 0, the device returns aborted error to the host.

### Output Parameters To The Device

<b>B</b>	Option bit for selection whether nonvolatile or volatile. B=0 is volatile condition. When B=1, MAX LBA/CYL which is set by Set Max LBA/CYL command is preserved by POR and HARD RESET. When B=0, MAX LBA/CYL which is set by Set Max LBA/CYL command will be lost by POR and HARD RESET.
<b>Sector Number</b>	In LBA mode, this register contains LBA bits 0 - 7 which is to be input.(L=1) In CHS mode, this register is ignored. (L=0)
<b>Cylinder High/Low</b>	In LBA mode, this register contains LBA bits 8 - 15 (Low), 16 - 23 (High) which is to be set. (L=1) In CHS mode, this register contains number of cylinders which is to be input.(L=0)
<b>H</b>	In LBA mode, this register contains LBA bits 24 - 27 which is to be input.(L=1) In CHS mode, this register is ignored. (L=0)
<b>L</b>	LBA mode.Indicates the addressing mode.L=0 specifies CHS mode and L=1 does LBA addressing mode.
<b>D</b>	The device number bit. Indicates that the device number bit of the Device/Head should be specified. D=0 selects the master device and D=1 selects the slave device.
<b>V</b>	Valid. Indicates that the bit is part of an output parameter and should be specified.
<b>-</b>	Indicates that the bit is not used.

### Input Parameters From The Device

<b>Sector Number</b>	In LBA mode, this register contains Adjusted Number of LBA bits 0 - 7.(L=1) In CHS mode, this register contains number of sectors(= 63). (L=0)
<b>Cylinder High/Low</b>	In LBA mode, this register contains Adjusted Number of LBA bits 8 - 15 (Low), 16 - 23 (High). (L=1) In CHS mode, this register contains number of cylinders which is set. (L=0)
<b>H</b>	In LBA mode, this register contains Adjusted Number of LBA bits 24 - 27. (L=1) In CHS mode, this register contains number of heads minus 1(= 15).(L=0)
<b>V</b>	Valid. Indicates that the bit is part of an input parameter and will be set to 0 or 1 by the device.
<b>-</b>	Indicates that the bit is not used.

## 12.27 Set Multiple (C6h)

Command Block Output Registers								
Register	7	6	5	4	3	2	1	0
Data	-	-	-	-	-	-	-	-
Feature	-	-	-	-	-	-	-	-
Sector Count	V	V	V	V	V	V	V	V
Sector Number	-	-	-	-	-	-	-	-
Cylinder Low	-	-	-	-	-	-	-	-
Cylinder High	-	-	-	-	-	-	-	-
Device/Head	1	-	1	D	-	-	-	-
Command	1	1	0	0	0	1	1	0

Command Block Input Registers								
Register	7	6	5	4	3	2	1	0
Data	-	-	-	-	-	-	-	-
Error	...See Below...							
Sector Count	-	-	-	-	-	-	-	-
Sector Number	-	-	-	-	-	-	-	-
Cylinder Low	-	-	-	-	-	-	-	-
Cylinder High	-	-	-	-	-	-	-	-
Device/Head	-	-	-	-	-	-	-	-
Status	...See Below...							

Error Register							
7	6	5	4	3	2	1	0
BBK	UNC	0	IDN	0	ABT	T0N	AMN
0	0	0	0	0	V	0	0

Status Register							
7	6	5	4	3	2	1	0
BSY	RDY	DF	DSC	DRQ	COR	IDX	ERR
0	V	0	-	-	0	-	V

Figure 83. Set Multiple Command (C6h)

The Set Multiple command enables the device to perform Read and Write Multiple commands and establishes the block size for these commands. The block size is the number of sectors to be transferred for each interrupt.

The default block size after power up, or hard reset is 0, and Read Multiple and Write Multiple commands are disabled.

If an invalid block size is specified, an Abort error will be returned to the host, and Read Multiple and Write Multiple commands will be disabled.

### Output Parameters To The Device

**Sector Count.** The block size to be used for Read Multiple and Write Multiple commands. Valid block sizes can be selected from 0, 2, 4, 8 or 16. If 0 is specified, then Read Multiple and Write Multiple commands are disabled.

## 12.28 Sleep (E6h/99h)

Command Block Output Registers								
Register	7	6	5	4	3	2	1	0
Data	-	-	-	-	-	-	-	-
Feature	-	-	-	-	-	-	-	-
Sector Count	-	-	-	-	-	-	-	-
Sector Number	-	-	-	-	-	-	-	-
Cylinder Low	-	-	-	-	-	-	-	-
Cylinder High	-	-	-	-	-	-	-	-
Device/Head	1	-	1	D	-	-	-	-
Command	1	1	1	0	0	1	1	0

Command Block Input Registers								
Register	7	6	5	4	3	2	1	0
Data	-	-	-	-	-	-	-	-
Error	...See Below...							
Sector Count	-	-	-	-	-	-	-	-
Sector Number	-	-	-	-	-	-	-	-
Cylinder Low	-	-	-	-	-	-	-	-
Cylinder High	-	-	-	-	-	-	-	-
Device/Head	-	-	-	-	-	-	-	-
Status	...See Below...							

Error Register							
7	6	5	4	3	2	1	0
BBK	UNC	0	IDN	0	ABT	T0N	AMN
0	0	0	0	0	V	0	0

Status Register							
7	6	5	4	3	2	1	0
BSY	RDY	DF	DSC	DRQ	COR	IDX	ERR
0	V	0	V	-	0	-	V

Figure 84. Sleep Command (E6h/99h)

This command is the only way to cause the device to enter Sleep Mode.

When this command is issued, the device confirms the completion of the cached write commands before asserts INTRQ. Then the device is spun down, and the interface becomes inactive. The only way to recover from Sleep Mode is with a software reset or a hardware reset.

The use of hardware reset to recover from Sleep Mode may be incompatible with continued operation of the host system.

If the device is already spun down, the spin down sequence is not executed.

## 12.29 S.M.A.R.T. Function Set (B0h)

Command Block Output Registers							
Register	7	6	5	4	3	2	1 0
Data	-	-	-	-	-	-	-
Feature	V	V	V	V	V	V	V
Sector Count	V	V	V	V	V	V	V
Sector Number	-	-	-	-	-	-	-
Cylinder Low	0	1	0	0	1	1	1
Cylinder High	1	1	0	0	0	0	1
Device/Head	1	-	1	D	-	-	-
Command	1	0	1	1	0	0	0

Command Block Input Registers							
Register	7	6	5	4	3	2	1 0
Data	-	-	-	-	-	-	-
Error	...See Below...						
Sector Count	-	-	-	-	-	-	-
Sector Number	-	-	-	-	-	-	-
Cylinder Low	-	-	-	-	-	-	-
Cylinder High	-	-	-	-	-	-	-
Device/Head	-	-	-	-	-	-	-
Status	...See Below...						

Error Register							
7	6	5	4	3	2	1	0
BBK	UNC	0	IDN	0	ABT	T0N	AMN
0	0	0	0	0	V	0	0

Status Register							
7	6	5	4	3	2	1	0
BSY	RDY	DF	DSC	DRQ	COR	IDX	ERR
0	V	0	V	-	0	-	V

Figure 85. S.M.A.R.T. Function Set Command (B0h)

The S.M.A.R.T. Function Set command provides access to Attribute Values, Attribute Thresholds and other low level subcommands that can be used for logging and reporting purposes and to accommodate special user needs. The S.M.A.R.T. Function Set command has several separate subcommands which are selectable via the device's Features Register when the S.M.A.R.T. Function Set command is issued by the host.

In order to select a subcommand the host must write the subcommand code to the device's Features Register before issuing the S.M.A.R.T. Function Set command. The subcommands and their respective codes are listed below.

Code	Subcommand
<b>D0h</b>	SMART Read Attribute Values
<b>D1h</b>	SMART Read Attribute Thresholds
<b>D2h</b>	SMART Enable/disable Attribute Autosave
<b>D3h</b>	SMART Save Attribute Values
<b>D4h</b>	SMART Execute Off-line Data Collection
<b>D8h</b>	SMART Enable Operations
<b>D9h</b>	SMART Disable Operations

### 12.29.1.1 SMART Read Attribute Values (Subcommand D0h)

This subcommand returns the device's Attribute Values to the host. Upon receipt of the SMART Read Attribute Values subcommand from the host, the device asserts BSY, saves any updated Attribute Values to the Attribute Data sectors, asserts DRQ, clears BSY, asserts INTRQ, and then waits for the host to transfer the 512 bytes of Attribute Value information from the device via the Data Register.

### 12.29.1.2 SMART Read Attribute Thresholds (Subcommand D1h)

This subcommand returns the device's Attribute Thresholds to the host. Upon receipt of the SMART Read Attribute Thresholds subcommand from the host, the device asserts BSY, reads the Attribute Thresholds from the Attribute Threshold sectors, asserts DRQ, clears BSY, asserts INTRQ, and then waits for the host to transfer the 512 bytes of Attribute Thresholds information from the device via the Data Register.

### 12.29.1.3 SMART Enable/Disable Attribute Autosave (Subcommand D2h)

This subcommand enables and disables the attribute autosave feature of the device. The SMART Enable/Disable Attribute Autosave subcommand allows the device to automatically save its updated Attribute Values to the Attribute Data Sector at the timing of the first transition to LP idle mode after 30 minutes since the last saving of Attribute Values; this subcommand causes the autosave feature to be disabled. The state of the Attribute Autosave feature (either enabled or disabled) will be preserved by the device across power cycle.

A value of 00h written by the host into the device's Sector Count Register before issuing the SMART Enable/Disable Attribute Autosave subcommand will cause this feature to be disabled. Disabling this feature does not preclude the device from saving Attribute Values to the Attribute Data sectors during some other normal operation such as during a power-up or power-down.

A value of F1h written by the host into the device's Sector Count Register before issuing the SMART Enable/Disable Attribute Autosave subcommand will cause this feature to be enabled. Any other non-zero value written by the host into this register before issuing the SMART Enable/Disable Attribute Autosave subcommand will not change the current Autosave status but the device will respond with the error code specified in Figure 91 on page 139.

The SMART Disable Operations subcommand disables the autosave feature along with the device's SMART operations.

Upon the receipt of the subcommand from the host, the device asserts BSY, enables or disables the Autosave feature, clears BSY and asserts INTRQ.

### 12.29.1.4 SMART Save Attribute Values (Subcommand D3h)

This subcommand causes the device to immediately save any updated Attribute Values to the device's Attribute Data sector regardless of the state of the Attribute Autosave feature. Upon receipt of the SMART Save Attribute Values subcommand from the host, the device asserts BSY, writes any updated Attribute Values to the Attribute Data sector, clears BSY and asserts INTRQ.

### **12.29.1.5 SMART Execute Off-line Immediate (Subcommand D4h)**

This subcommand causes the device to immediately initiate the set of off-line data collection activities that collect attribute data in an off-line mode.

Upon receipt of the subcommand from the host, the device sets BSY to one, begins its set of off-line data collection activities, clears BSY to zero and asserts INTRQ.

During execution of its off-line activities the device will not set BSY nor clear DRDY.

If the device is in the process of performing its set of off-line data collection activities as a result of receiving a S.M.A.R.T. Execute Off-line Immediate subcommand from the host and is interrupted by any new command from the host, the device will abort its off-line data collection activities and service the host within two seconds after receipt of the new command. Off-line data collection activity must be restarted by a new S.M.A.R.T. Execute Off-line Immediate subcommand from the host.

### **12.29.1.6 SMART Enable Operations (Subcommand D8h)**

This subcommand enables access to all S.M.A.R.T. capabilities within the device. Prior to receipt of an SMART Enable Operations subcommand, Attribute Values are neither monitored nor saved by the device. The state of S.M.A.R.T. (either enabled or disabled) will be preserved by the device across power cycles. Once enabled, the receipt of subsequent SMART Enable Operations subcommands will not affect any of the Attribute Values.

Upon receipt of the SMART Enable Operations subcommand from the host, the device asserts BSY, enables S.M.A.R.T. capabilities and functions, clears BSY and asserts INTRQ.

### **12.29.1.7 SMART Disable Operations (Subcommand D9h)**

This subcommand disables all S.M.A.R.T. capabilities within the device including the device's attribute autosave feature. After receipt of this subcommand the device disables all S.M.A.R.T. operations. Non self-preserved Attribute Values will no longer be monitored. The state of S.M.A.R.T. (either enabled or disabled) is preserved by the device across power cycles. Note that this subcommand does not preclude the device's power mode attribute autosaving.

Upon receipt of the SMART Disable Operations subcommand from the host, the device asserts BSY, disables S.M.A.R.T. capabilities and functions, clears BSY and asserts INTRQ.

After receipt of the device of the SMART Disable Operations subcommand from the host, all other S.M.A.R.T. subcommands -- with the exception of SMART Enable Operations -- are disabled and invalid and will be aborted by the device (including the SMART Disable Operations subcommand), returning the error code as specified in Figure 91 on page 139.

Any Attribute Values accumulated and saved to volatile memory prior to receipt of the SMART Disable Operations command will be preserved in the device's Attribute Data Sectors. If the device is re-enabled, these Attribute Values will be updated, as needed, upon receipt of a SMART Read Attribute Values or SMART Save Attribute Values command.

### **12.29.1.8 SMART Return Status (Subcommand DAh)**

This command is used to communicate the reliability status of the device to the host's request. Upon receipt of the SMART Return Status subcommand the device asserts BSY, saves any updated Attribute Values to the reserved sector and compares the updated Attribute Values to the Attribute Thresholds.

If the device does not detect a Threshold Exceeded Condition, the device loads 4Fh into the Cylinder Low register, C2h into the Cylinder High register, clears BSY, and asserts INTRQ.

If the device detect a Threshold Exceeded Condition, the device loads F4h into the Cylinder Low register, 2Ch into the Cylinder High register, clears BSY, and asserts INTRQ.

### **12.29.2 Device Attributes Data Structure**

The following defines the 512 bytes that make up the Attribute Value information. This data structure is accessed by the host in its entirety using the SMART Read Attribute Values subcommand. All multi-byte fields shown in these data structures follow the ATA-3 specification for byte ordering, namely that the least significant byte occupies the lowest numbered byte address location in the field.

Description	Bytes	Offset	Format	Value
Data Structure Revision Number	2	00h	binary	0005h
1st Device Attribute	12	02h	(*1)	(*2)
...	..			
...	..			
30th Device Attribute	12	15Eh	(*1)	(*2)
Off-line data collection status	1	16Ah	(*1)	(*2)
Total segments required for off-line data collection	1	16Bh	(*1)	07h
Total time in seconds to complete next segment	2	16Ch	(*1)	(*2)
Current segment pointer	1	16Eh	(*1)	(*2)
Off-line data collection capability	1	16Fh	(*1)	05h
S.M.A.R.T. capability	2	170h	(*1)	03h
Reserved	16	172h		(*3)
Vendor specific	125	182h		(*3)
Data structure checksum	1	1FFh		(*2)
	512			

- (\*1) – See following definitions
- (\*2) – Value varied by actual operating condition
- (\*3) – Filled with 00h

Figure 86. Device Attribute Data Structure

### 12.29.2.1 Data Structure Revision Number

The Data Structure Revision Number identifies which version of this data structure is implemented by the device. This revision number will be set to 0005h. This revision number identifies both the Attribute Value and Attribute Threshold Data structures.

### 12.29.2.2 Individual Attribute Data Structure

The following defines the 12 bytes that make up the information for each Attribute entry in the Device Attribute Data Structure.

Description	Bytes	Offset	Format
Attribute ID Number (01h to FFh)	1	00h	binary
Status Flags	2	01h	bit flags
Bit 0 Pre-Failure/Advisory			
Bit 1 On-line Collection			
Bit 2-5 Reserved (may either 0 or 1)			
Bit 6-10 Reserved (all 0)			
Attribute Value (valid values from 01h to FEh)	1	03h	binary
00h invalid for attribute value - not to be used			
01h minimum value			
64h initial value for all attributes prior to any data collection			
FDh maximum value			
FEh value is not valid			
FFh invalid for attribute value - not to be used			
Reserved (may not be 0)	1	04h	binary
Reserved (may not be 0)	6	05h	binary
Reserved (00h)	1	0Bh	binary
Total Bytes	12		

Figure 87. Individual Attribute Data Structure

**12.29.2.2.1 Attribute ID Numbers:** Any non-zero value in the Attribute ID Number indicates an active attribute. The device supports following Attribute ID Numbers. Those marked with (\*) indicate that corresponding Attribute Values can be either collected on-line or off-line.

ID	Attribute Name
0	Indicates that this entry in the data structure is not used
1	Raw Read Error Rate (*)
2	Throughput Performance (*)
3	Spin Up Time
4	Start/Stop Count
5	Reallocated Sector Count

<b>7</b>	Seek Error Rate
<b>8</b>	Seek Time Performance (*)
<b>9</b>	Power-On Hours Count
<b>10</b>	Spin Retry Count
<b>12</b>	Device Power Cycle Count
<b>220</b>	Disk Shift

### 12.29.2.2.2 Status Flag Definitions

Bit	Flag Name	Definition
0	Pre-Failure/ Advisory bit	If bit = 0, an Attribute Value less than or equal to its corresponding Attribute Threshold indicates an Advisory condition where the usage or age of the device has exceeded its intended design life period. If bit = 1, an Attribute Value less than or equal to its corresponding Attribute Threshold indicates a Pre-Failure condition where imminent loss of data is being predicted.
1	On-Line Collective bit	If bit = 0, the Attribute Value is updated only during Off-Line testing. If bit = 1, the Attribute Value is updated only during On-Line testing
2-5	Reserved bits	may either 0 or 1
6-15	Reserved bits	Always 0

Figure 88. Status Flag Definitions

**12.29.2.2.3 Normalized Values:** The device will perform conversion of the raw Attribute Values to transform them into normalized values, which the host can then compare with the Threshold values. A Threshold is the excursion limit for a normalized Attribute Value. In normalizing the raw data, the device will perform any necessary statistical validity checks to ensure that an instantaneous raw value is not improperly reflected in the normalized Attribute Value (i.e., one read error in the first 10 reads being interpreted as exceeding the read error rate threshold when the subsequent 1 billion reads all execute without error). The end points for the normalized values for all Attributes will be 1 (01h) at the low end, and 100 (64h) at the high end for the device which is ready for customer shipment. For Performance and Error Rate Attributes, values greater than 100 are also possible, up to a maximum value of 253 (FDh).

### 12.29.2.3 Off-Line Data Collection Status

The value of this byte defines the current status of the off-line activities of the device. Bit 7 indicates Automatic Off-Line Data Collection Status.

**Bit 7                    Automatic Off-Line Data Collection Status**

**0**                    Automatic Off-Line Data Collection is enabled.

**1**                    Automatic Off-Line Data Collection is disabled.

Bits 0 thru 6 represents a hexadecimal status value reported by the device.

**Value            Definition**

**0**                    Off-line data collection never started

- 1 Segment completed without error
- 2 All segments completed without errors. In this case, current segment pointer equals to total segments required.
- 5 Off-line data collecting aborted by interrupting command
- 6 Off-line data collection aborted with fatal error

#### 12.29.2.4 Total Segments Required for Off-line Data Collection

The device will return 07h as the total segments for off-line data collection. The device divides its off-line data collection activity into 7 segments. These segments consists of: segment 1 through 4 = raw read error rate and throughput measurement, segment 5 = 1000 track to track seeks, segment 6 = 1000 1/3 stroke seeks, and segment 7 = 1000 full stroke seeks.

#### 12.29.2.5 Total Time in Seconds to Complete Next Segment

This field tells the host how many seconds the device requires to complete the segment pointed by the current segment pointer. The host can use this time to set a count down timer that will trigger it to issue the “SMART Read Attribute Values” subcommand to check on the status of off-line data collection. This field indicates the total time in seconds for the first segment if the current segment pointer is 00h or the off-line status indicates all segments completed (02h).

#### 12.29.2.6 Current Segment Pointer

This byte is a counter indicating the next segment to execute as an off-line data collection activity. This varies from 00h to the total number of segments. The current segment pointer will be 00h if the off-line data collection has not been started. If the off-line data collection is aborted by a command or an error (i.e., the status is 05h or 06h), this byte will point to the aborted segment. If the all segments complete, this byte will equal to the total number of segments.

#### 12.29.2.7 Off-Line Data Collection Capability

The device returns 05h as its off-line data collection capability which means:

Bit	Definition
0	Execute Off-line Immediate is implemented
1	Enable/Disable Automatic Off-line is NOT implemented
2	Abort/restart off-line by host

The device will abort all off-line data collection activity initiated by an S.M.A.R.T. Execute Off-line Immediate subcommand upon receipt of a new command. Off-line data collection activity must be restarted by a new S.M.A.R.T. Execute Off-line Immediate subcommand from the host.

### 12.29.2.8 S.M.A.R.T. Capability

This word of bit flags describes the S.M.A.R.T. capabilities of the device. The device will return 03h as its S.M.A.R.T. capability which means:

Bit	Definition
0	Power mode attribute saving capability  If bit = 1, the device will save its Attribute Values prior to going into a power saving mode (Standby or Sleep mode).
1	Attribute autosave after event capability  The device supports the S.M.A.R.T. Enable/Disable Attribute Autosave subcommand.
2-15	Reserved (0)

### 12.29.2.9 Data Structure Checksum

The Data Structure Checksum is the 2's compliment of the result of a simple 8-bit addition of the first 511 bytes in the data structure.

### 12.29.3 Device Attribute Thresholds Data Structure

The following defines the 512 bytes that make up the Attribute Threshold information. This data structure is accessed by the host in its entirety using the SMART Read Attribute Thresholds. All multi-byte fields shown in these data structures follow the ATA-2 specification for byte ordering, namely that the least significant byte occupies the lowest numbered byte address location in the field.

The sequence of active Attribute Thresholds will appear in the same order as their corresponding Attribute Values.

Description	Bytes	Offset	Format	Value
Data Structure Revision Number	2	00h	binary	0005h
1st Attribute Threshold	12	02h	(*1)	(*2)
...	..			
...	..			
30th Attribute Threshold	12	15Eh	(*1)	(*2)
Reserved	18	16Ah		(*3)
Vendor specific	131	17Ch		(*3)
Data structure checksum	1	1FFh		(*2)
	512			

(\*1) – See following definitions

(\*2) – Value varied by actual operating condition

(\*3) – Filled with 00h

Figure 89. Device Attribute Thresholds Data Structure

### 12.29.3.1 Data Structure Revision Number

This value (0005h) is the same as the value used in the Device Attributes Values Data Structure.

### 12.29.3.2 Individual Thresholds Data Structure

The following defines the 12 bytes that make up the information for each Threshold entry in the Device Attribute Thresholds Data Structure. Attribute entries in the Individual Threshold Data Structure is in the same order and correspond to the entries in the Individual Attribute Data Structure.

Description	Bytes	Offset	Format
Attribute ID Number (01h to FFh)	1	00h	binary
Attribute Threshold (for comparison with Attribute Values from 00h to FFh)	1	01h	binary
00h – "always passing" threshold value to be used for code test purposes			
01h – minimum value for normal operation			
FDh – maximum value for normal operation			
FEh – invalid for threshold value			
FFh – "always failing" threshold value to be used for code test purposes			
Reserved (00h)	10	02h	binary
Total Bytes	12		

Figure 90. Individual Threshold Data Structure

### 12.29.3.3 Attribute ID Numbers

Attribute ID Numbers supported by the device are the same as Attribute Values Data Structures.

### 12.29.3.4 Attribute Threshold

These values are preset at the factory and are not meant to be changeable. However, the host might use "SMART Write Attribute Threshold" subcommand to override these preset values in the Threshold sectors.

### 12.29.3.5 Data Structure Checksum

The Data Structure Checksum is the 2's compliment of the result of a simple 8-bit addition of the first 511 bytes in the data structure.

## 12.29.4 Error Reporting

The following table shows the values returned in the Status and Error Registers when specific error conditions are encountered by a device.

Error Condition	Status Register	Error Register
A S.M.A.R.T. FUNCTION SET command was received by the device without the required key being loaded into the Cylinder High and Cylinder Low registers.	51h	04h
A S.M.A.R.T. FUNCTION SET command was received by the device with a subcommand value in the Features Register that is either invalid or not supported by this device.	51h	04h
A S.M.A.R.T. FUNCTION SET command subcommand other than SMART ENABLE OPERATIONS was received by the device while the device was in a "S.M.A.R.T. disabled" state.	51h	04h
The device is unable to read its Attribute Values or Attribute Thresholds data structure.	51h	10h or 40h
The device is unable to write to its Attribute Values data structure.	51h	10h or 01h

Figure 91. S.M.A.R.T. Error Codes

## 12.30 Standby (E2h/96h)

Command Block Output Registers								
Register	7	6	5	4	3	2	1	0
Data	-	-	-	-	-	-	-	-
Feature	-	-	-	-	-	-	-	-
Sector Count	V	V	V	V	V	V	V	V
Sector Number	-	-	-	-	-	-	-	-
Cylinder Low	-	-	-	-	-	-	-	-
Cylinder High	-	-	-	-	-	-	-	-
Device/Head	1	-	1	D	-	-	-	-
Command	1	1	1	0	0	0	1	0

Command Block Input Registers								
Register	7	6	5	4	3	2	1	0
Data	-	-	-	-	-	-	-	-
Error	...See Below...							
Sector Count	-	-	-	-	-	-	-	-
Sector Number	-	-	-	-	-	-	-	-
Cylinder Low	-	-	-	-	-	-	-	-
Cylinder High	-	-	-	-	-	-	-	-
Device/Head	-	-	-	-	-	-	-	-
Status	...See Below...							

Error Register							
7	6	5	4	3	2	1	0
BBK	UNC	0	IDN	0	ABT	T0N	AMN
0	0	0	0	0	V	0	0

Status Register							
7	6	5	4	3	2	1	0
BSY	RDY	DF	DSC	DRQ	COR	IDX	ERR
0	V	0	V	-	0	-	V

Figure 92. Standby Command (E2h/96h)

The Standby command causes the device to enter the Standby Mode immediately, and set auto power down timeout parameter(standby timer).

When this command is issued, the device confirms the completion of the cached write commands before asserts INTRQ. Then the device is spun down, but the interface remains active.

If the device is already spun down, the spin down sequence is not executed.

During the Standby mode the device will respond to commands, but there is a delay while waiting for the spindle to reach operating speed.

The timer starts counting down when the device returns to Idle mode.

### Output Parameters To The Device

**Sector Count** Timeout Parameter. If zero, the timeout interval(Standby Timer) is NOT disabled, but the timeout interval is set for 109 minutes automatically. If other than zero, the timeout interval is set for (Timeout Parameter × 5) seconds.

When the automatic power down sequence is enabled,

The device will enter Standby mode automatically if the timeout interval expires with no device access from the host. The timeout interval will be reinitialized if there is a device access before the timeout interval expires.

## 12.31 Standby Immediate (E0h/94h)

Command Block Output Registers								
Register	7	6	5	4	3	2	1	0
Data	-	-	-	-	-	-	-	-
Feature	-	-	-	-	-	-	-	-
Sector Count	-	-	-	-	-	-	-	-
Sector Number	-	-	-	-	-	-	-	-
Cylinder Low	-	-	-	-	-	-	-	-
Cylinder High	-	-	-	-	-	-	-	-
Device/Head	1	-	1	D	-	-	-	-
Command	1	1	1	0	0	0	0	0

Command Block Input Registers								
Register	7	6	5	4	3	2	1	0
Data	-	-	-	-	-	-	-	-
Error	...See Below...							
Sector Count	-	-	-	-	-	-	-	-
Sector Number	-	-	-	-	-	-	-	-
Cylinder Low	-	-	-	-	-	-	-	-
Cylinder High	-	-	-	-	-	-	-	-
Device/Head	-	-	-	-	-	-	-	-
Status	...See Below...							

Error Register							
7	6	5	4	3	2	1	0
BBK	UNC	0	IDN	0	ABT	T0N	AMN
0	0	0	0	0	V	0	0

Status Register							
7	6	5	4	3	2	1	0
BSY	RDY	DF	DSC	DRQ	COR	IDX	ERR
0	V	0	V	-	0	-	V

Figure 93. Standby Immediate Command (E0h/94h)

The Standby Immediate command causes the device to enter Standby mode immediately.

When this command is issued, the device confirms the completion of the cached write commands before asserts INTRQ. Then the device is spun down, but the interface remains active.

If the device is already spun down, the spin down sequence is not executed.

During the Standby mode, the device will respond to commands, but there is a delay while waiting for the spindle to reach operating speed.

The Standby Immediate command will not affect to auto power down timeout parameter.

## 12.32 Write Buffer (E8h)

Command Block Output Registers								
Register	7	6	5	4	3	2	1	0
Data	-	-	-	-	-	-	-	-
Feature	-	-	-	-	-	-	-	-
Sector Count	-	-	-	-	-	-	-	-
Sector Number	-	-	-	-	-	-	-	-
Cylinder Low	-	-	-	-	-	-	-	-
Cylinder High	-	-	-	-	-	-	-	-
Device/Head	1	-	1	D	-	-	-	-
Command	1	1	1	0	1	0	0	0

Command Block Input Registers								
Register	7	6	5	4	3	2	1	0
Data	-	-	-	-	-	-	-	-
Error	...See Below...							
Sector Count	-	-	-	-	-	-	-	-
Sector Number	-	-	-	-	-	-	-	-
Cylinder Low	-	-	-	-	-	-	-	-
Cylinder High	-	-	-	-	-	-	-	-
Device/Head	-	-	-	-	-	-	-	-
Status	...See Below...							

Error Register							
7	6	5	4	3	2	1	0
BBK	UNC	0	IDN	0	ABT	T0N	AMN
0	0	0	0	0	V	0	0

Status Register							
7	6	5	4	3	2	1	0
BSY	RDY	DF	DSC	DRQ	COR	IDX	ERR
0	V	0	-	-	0	-	V

Figure 94. Write Buffer Command (E8h)

The Write Buffer command transfers a sector of data from the host to the sector buffer of the device. The sectors of data are transferred through the Data Register 16 bits at a time.

The Read Buffer and Write Buffer commands are synchronized such that sequential Write Buffer and Read Buffer commands access the same 512 byte within buffer.

## 12.33 Write DMA (CAh/CBh)

Command Block Output Registers								
Register	7	6	5	4	3	2	1	0
Data	-	-	-	-	-	-	-	-
Feature	-	-	-	-	-	-	-	-
Sector Count	V	V	V	V	V	V	V	V
Sector Number	V	V	V	V	V	V	V	V
Cylinder Low	V	V	V	V	V	V	V	V
Cylinder High	V	V	V	V	V	V	V	V
Device/Head	1	L	1	D	H	H	H	H
Command	1	1	0	0	1	0	1	R

Command Block Input Registers								
Register	7	6	5	4	3	2	1	0
Data	-	-	-	-	-	-	-	-
Error	...See Below...							
Sector Count	V	V	V	V	V	V	V	V
Sector Number	V	V	V	V	V	V	V	V
Cylinder Low	V	V	V	V	V	V	V	V
Cylinder High	V	V	V	V	V	V	V	V
Device/Head	-	-	-	-	H	H	H	H
Status	...See Below...							

Error Register							
7	6	5	4	3	2	1	0
BBK	UNC	0	IDN	0	ABT	T0N	AMN
0	0	0	V	0	V	0	0

Status Register							
7	6	5	4	3	2	1	0
BSY	RDY	DF	DSC	DRQ	COR	IDX	ERR
0	V	V	V	-	0	-	V

Figure 95. Write DMA Command (CAh/CBh)

The Write DMA command transfers one or more sectors of data from the host to the device, then the data is written to the disk media.

The sectors of data are transferred through the Data Register 16 bits at a time.

The host initializes a slave-DMA channel prior to issuing the command. Data transfers are qualified by DMARQ and are performed by the slave-DMA channel. The device issues only one interrupt per command to indicate that data transfer has terminated and status is available.

If an uncorrectable error occurs, the write will be terminated at the failing sector.

### Output Parameters To The Device

**Sector Count** The number of continuous sectors to be transferred. If zero is specified, then 256 sectors will be transferred.

**Sector Number** The sector number of the first sector to be transferred. (L=0)  
In LBA mode, this register contains LBA bits 0 - 7. (L=1)

**Cylinder High/Low** The cylinder number of the first sector to be transferred. (L=0)  
In LBA mode, this register contains LBA bits 8 - 15 (Low), 16 - 23 (High). (L=1)

- H** The head number of the first sector to be transferred. (L=0)  
In LBA mode, this register contains LBA bits 24 - 27. (L=1)
- R** The retry bit. If set to one, then retries are disabled. But ignored, when write cache is enabled. (Ignoring the retry bit is in violation of ATA-2.)

**Input Parameters From The Device**

- Sector Count** The number of requested sectors not transferred. This will be zero, unless an unrecoverable error occurs.
- Sector Number** The sector number of the last transferred sector. (L=0)  
In LBA mode, this register contains current LBA bits 0 - 7. (L=1)
- Cylinder High/Low** The cylinder number of the last transferred sector. (L=0)  
In LBA mode, this register contains current LBA bits 8 - 15 (Low), 16 - 23 (High). (L=1)
- H** The head number of the last transferred sector. (L=0)  
In LBA mode, this register contains current LBA bits 24 - 27. (L=1)

## 12.34 Write Long (32h/33h)

Command Block Output Registers								
Register	7	6	5	4	3	2	1	0
Data	-	-	-	-	-	-	-	-
Feature	-	-	-	-	-	-	-	-
Sector Count	0	0	0	0	0	0	0	1
Sector Number	V	V	V	V	V	V	V	V
Cylinder Low	V	V	V	V	V	V	V	V
Cylinder High	V	V	V	V	V	V	V	V
Device/Head	1	L	1	D	H	H	H	H
Command	0	0	1	1	0	0	1	R

Command Block Input Registers								
Register	7	6	5	4	3	2	1	0
Data	-	-	-	-	-	-	-	-
Error	...See Below...							
Sector Count	-	-	-	-	-	-	-	V
Sector Number	V	V	V	V	V	V	V	V
Cylinder Low	V	V	V	V	V	V	V	V
Cylinder High	V	V	V	V	V	V	V	V
Device/Head	-	-	-	-	H	H	H	H
Status	...See Below...							

Error Register							
7	6	5	4	3	2	1	0
BBK	UNC	0	IDN	0	ABT	T0N	AMN
0	0	0	V	0	V	0	0

Status Register							
7	6	5	4	3	2	1	0
BSY	RDY	DF	DSC	DRQ	COR	IDX	ERR
0	V	V	V	-	0	-	V

Figure 96. Write Long Command (32h/33h)

The Write Long command transfers the data and the ECC bytes of the designated one sector from the host to the device, then the data and the ECC bytes are written to the disk media.

After 512 bytes of data have been transferred, the device will keep setting DRQ=1 to indicate that the device is ready to receive the ECC bytes from the host. The data is transferred 16 bits at a time, and the ECC bytes are transferred 8 bits at a time. The number of ECC bytes are 4 or 20 according to setting of Set Feature option. The default number after power on is 4 bytes.

### Output Parameters To The Device

- Sector Count** The number of continuous sectors to be transferred. The Sector Count must be set to one.
- Sector Number** The sector number of the sector to be transferred. (L=0)  
In LBA mode, this register contains LBA bits 0 - 7. (L=1)
- Cylinder High/Low** The cylinder number of the sector to be transferred. (L=0)  
In LBA mode, this register contains LBA bits 8 - 15 (Low), 16 - 23 (High). (L=1)
- H** The head number of the sector to be transferred. (L=0)  
In LBA mode, this register contains LBA bits 24 - 27. (L=1)
- R** The retry bit. If set to one, then retries are disabled.

### **Input Parameters From The Device**

<b>Sector Count</b>	The number of requested sectors not transferred.
<b>Sector Number</b>	The sector number of the sector to be transferred. (L=0) In LBA mode, this register contains current LBA bits 0 - 7. (L=1)
<b>Cylinder High/Low</b>	The cylinder number of the sector to be transferred. (L=0) In LBA mode, this register contains current LBA bits 8 - 15 (Low), 16 - 23 (High). (L=1)
<b>H</b>	The head number of the sector to be transferred. (L=0) In LBA mode, this register contains current LBA bits 24 - 27. (L=1)

The file internally uses 20 bytes of ECC on all data read or writes. The 4 byte mode of operation is provided via an emulation technique. As a consequence of this emulation it is recommended that 20 byte ECC mode is used for all tests to confirm the operation of the files ECC hardware. Unexpected results may occur if such testing is performed using 4 byte mode.

## 12.35 Write Multiple (C5h)

Command Block Output Registers								
Register	7	6	5	4	3	2	1	0
Data	-	-	-	-	-	-	-	-
Feature	-	-	-	-	-	-	-	-
Sector Count	V	V	V	V	V	V	V	V
Sector Number	V	V	V	V	V	V	V	V
Cylinder Low	V	V	V	V	V	V	V	V
Cylinder High	V	V	V	V	V	V	V	V
Device/Head	1	L	1	D	H	H	H	H
Command	1	1	0	0	0	1	0	1

Command Block Input Registers								
Register	7	6	5	4	3	2	1	0
Data	-	-	-	-	-	-	-	-
Error	...See Below...							
Sector Count	V	V	V	V	V	V	V	V
Sector Number	V	V	V	V	V	V	V	V
Cylinder Low	V	V	V	V	V	V	V	V
Cylinder High	V	V	V	V	V	V	V	V
Device/Head	-	-	-	-	H	H	H	H
Status	...See Below...							

Error Register							
7	6	5	4	3	2	1	0
BBK	UNC	0	IDN	0	ABT	T0N	AMN
0	0	0	V	0	V	0	0

Status Register							
7	6	5	4	3	2	1	0
BSY	RDY	DF	DSC	DRQ	COR	IDX	ERR
0	V	V	V	-	0	-	V

Figure 97. Write Multiple Command (C5h)

The Write Multiple command transfers one or more sectors from the host to the device, the the data is written to the disk media.

Command execution is identical to the Write Sectors command except that an interrupt is generated for each block (as defined by the Set Multiple command) instead of for each sector. The sectors are transferred through the Data Register 16 bits at a time.

### Output Parameters To The Device

- Sector Count** The number of continuous sectors to be transferred. If zero is specified, then 256 sectors will be transferred.
- Sector Number** The sector number of the first sector to be transferred. (L=0)  
In LBA mode, this register contains LBA bits 0 - 7. (L=1)
- Cylinder High/Low** The cylinder number of the first sector to be transferred. (L=0)  
In LBA mode, this register contains LBA bits 8 - 15 (Low), 16 - 23 (High). (L=1)
- H** The head number of the first sector to be transferred. (L=0)  
In LBA mode, this register contains LBA bits 24 - 27. (L=1)

### Input Parameters From The Device

<b>Sector Count</b>	The number of requested sectors not transferred. This will be zero, unless an unrecoverable error occurs.
<b>Sector Number</b>	The sector number of the last transferred sector. (L=0) In LBA mode, this register contains current LBA bits 0 - 7. (L=1)
<b>Cylinder High/Low</b>	The cylinder number of the last transferred sector. (L=0) In LBA mode, this register contains current LBA bits 8 - 15 (Low), 16 - 23 (High). (L=1)
<b>H</b>	The head number of the last transferred sector. (L=0) In LBA mode, this register contains current LBA bits 24 - 27. (L=1)

## 12.36 Write Sectors (30h/31h)

Command Block Output Registers								
Register	7	6	5	4	3	2	1	0
Data	-	-	-	-	-	-	-	-
Feature	-	-	-	-	-	-	-	-
Sector Count	V	V	V	V	V	V	V	V
Sector Number	V	V	V	V	V	V	V	V
Cylinder Low	V	V	V	V	V	V	V	V
Cylinder High	V	V	V	V	V	V	V	V
Device/Head	1	L	1	D	H	H	H	H
Command	0	0	1	1	0	0	0	R

Command Block Input Registers								
Register	7	6	5	4	3	2	1	0
Data	-	-	-	-	-	-	-	-
Error	...See Below...							
Sector Count	V	V	V	V	V	V	V	V
Sector Number	V	V	V	V	V	V	V	V
Cylinder Low	V	V	V	V	V	V	V	V
Cylinder High	V	V	V	V	V	V	V	V
Device/Head	-	-	-	-	H	H	H	H
Status	...See Below...							

Error Register							
7	6	5	4	3	2	1	0
BBK	UNC	0	IDN	0	ABT	T0N	AMN
0	0	0	V	0	V	0	0

Status Register							
7	6	5	4	3	2	1	0
BSY	RDY	DF	DSC	DRQ	COR	IDX	ERR
0	V	V	V	-	0	-	V

Figure 98. Write Sectors Command (30h/31h)

The Write Sectors command transfers one or more sectors from the host to the device, then the data is written to the disk media.

The sectors are transferred through the Data Register 16 bits at a time.

If an uncorrectable error occurs, the write will be terminated at the failing sector.

### Output Parameters To The Device

- Sector Count** The number of continuous sectors to be transferred. If zero is specified, then 256 sectors will be transferred.
- Sector Number** The sector number of the first sector to be transferred. (L=0)  
In LBA mode, this register contains LBA bits 0 - 7. (L=1)
- Cylinder High/Low** The cylinder number of the first sector to be transferred. (L=0)  
In LBA mode, this register contains LBA bits 8 - 15 (Low), 16 - 23 (High). (L=1)
- H** The head number of the first sector to be transferred. (L=0)  
In LBA mode, this register contains LBA bits 24 - 27. (L=1)
- R** The retry bit. If set to one, then retries are disabled. But ignored, when write cache is enabled. (Ignoring the retry bit is in violation of ATA-2.)

### Input Parameters From The Device

<b>Sector Count</b>	The number of requested sectors not transferred. This will be zero, unless an unrecoverable error occurs.
<b>Sector Number</b>	The sector number of the last transferred sector. (L=0) In LBA mode, this register contains current LBA bits 0 - 7. (L=1)
<b>Cylinder High/Low</b>	The cylinder number of the last transferred sector. (L=0) In LBA mode, this register contains current LBA bits 8 - 15 (Low), 16 - 23 (High). (L=1)
<b>H</b>	The head number of the last transferred sector. (L=0) In LBA mode, this register contains current LBA bits 24 - 27. (L=1)

---

## 12.37 Write Verify (3Ch: Vendor Specific)

In DMCA-2xxx implementation, Write Verify command is exactly same as Write Sectors command(30h). No read verification is performed after write operation.

Refer Write Sectors Command for parameters.



## 13.0 Timings

The timing of BSY and DRQ in Status Register are shown in Figure 99.

FUNCTION	INTERVAL	START	STOP	TIMEOUT
Power On	Device Busy After Power On	Power On	Status Register BSY=1	400 ns
	Device Ready After Power On	Power On	Status Register BSY=0 and RDY=1	31 sec
Software Reset	Device Busy After Software Reset	Device Control Register RST=1	Status Register BSY=1	400 ns
	Device Ready After Software Reset	Device Control Register RST=1	Status Register BSY=0 and RDY=1	6 sec
Hard Reset	Device Busy After Hard Reset	Bus RESET Signal Asserted	Status Register BSY=1	400 ns
	Device Ready After Hard Reset	Bus RESET Signal Asserted	Status Register BSY=0 and RDY=1	31 sec
Data In Command	Device Busy After Command Code Out	OUT to Command Register	Status Register BSY=1	400 ns
	Interrupt, DRQ For Data Transfer In	Status Register BSY=1	Status Register BSY=0 and DRQ=1, Interrupt	30 sec
	Device Busy After Data Transfer In	256th Read From Data Register	Status Register BSY=1	10 us
Data Out Command	Device Busy After Command Code Out	OUT to Command Register	Status Register BSY=1	400 ns
	Data Request For Data Transfer Out	Status Register BSY=1	Status Register BSY=0 and DRQ=1	700 us (Note.3)
	Device Busy After Data Transfer Out	256th Write From Data Register	Status Register BSY=1	5 us
	Interrupt For Data Transfer Out	Status Register BSY=1	Status Register BSY=0 and RDY=1 Interrupt	30 sec (Note.1)
Non-Data Command	Device Busy After Command Code Out	OUT to Command Register	Status Register BSY=1	400 ns
	Interrupt For Command Complete	Status Register BSY=1	Interrupt	30 sec (Note.2)

Figure 99. Timeout Values

FUNCTION	INTERVAL	START	STOP	TIMEOUT
DMA Data Transfer Command	Device Busy after Command Code Out	Out to Command Register	Status Register BSY=1	400 ns

Figure 100. Timeout Values --- Continued ---

Command category is referred to 11.0, “ Command Protocol” on page 73.

The abbreviations "ns", "us", "ms" and "sec" mean nanoseconds, microseconds, milliseconds and seconds, respectively.

We recommend that the host system executes Soft reset and then retry to issue the command if the host system would occur timeout for the device.

**(Note.1)** For SECURITY ERASE UNIT command, the timeout value is 15 minutes.

**(Note.2)** For FORMAT UNIT command, the timeout value is 15 minutes.

**(Note.3)** When the initial power mode at power on is Standby mode, and when the following commands are issued by the host as First Command, the command's timeout value of the field is 10 seconds.

Security Disable Password, Security Erase Unit,

Security Set Password, Security Unlock.





## 14.0 Appendix

### 14.1 Commands Support Coverage

Following table is provided to facilitate the understanding of DMCA-2xxxx command support coverage comparing to the ATA-3 defined command set. The column of 'Implementation' shows the capability of DMCA-2xxxx for those commands.

Command Code	Command Name		Implementation for DMCA-2XXXX	ATA-3 Category
00h	NOP		No	Optional
01h-0Fh	Reserved		Reserved	Reserved
1xh	RECALIBRATE		Yes	Optional
20h	READ SECTOR(S)	(w/ retry)	Yes	Mandatory
21h	READ SECTOR(S)	(w/o retry)	Yes	Mandatory
22h	READ LONG	(w/ retry)	Yes	Optional
23h	READ LONG	(w/o retry)	Yes	Optional
24h-2Fh	Reserved		Reserved	Reserved
30h	WRITE SECTOR(S)	(w/ retry)	Yes	Mandatory
31h	WRITE SECTOR(S)	(w/o retry)	Yes	Mandatory
32h	WRITE LONG	(w/ retry)	Yes	Optional
33h	WRITE LONG	(w/o retry)	Yes	Optional
34h-3Bh	Reserved		Reserved	Reserved
3Ch	WRITE VERIFY (2)		Vendor specific	Optional
3Dh-3Fh	Reserved		Reserved	Reserved
40h	READ VERIFY SECTOR(S)	(w/ retry)	Yes	Mandatory
41h	READ VERIFY SECTOR(S)	(w/o retry)	Yes	Mandatory
42h-4Fh	Reserved		Reserved	Reserved
50h	FORMAT TRACK		Yes	Vendor specific
51h-5Fh	Reserved		Reserved	Reserved
60h-6Fh	Reserved		Reserved	Reserved
7xh	SEEK		Yes	Mandatory
8xh	Vendor specific		Reserved	Vendor specific
90h	EXECUTE DEVICE DIAGNOSTIC		Yes	Mandatory
91h	INITIALIZE DEVICE PARAMETERS		Yes	Mandatory
92h	DOWNLOAD MICROCODE		No	Optional
93h	Reserved		Reserved	Reserved
94h,E0h	STANDBY IMMEDIATE (1)		Yes	Optional (4)
95h,E1h	IDLE IMMEDIATE (1)		Yes	Optional (4)
96h,E2h	STANDBY (1)		Yes	Optional (4)
97h,E3h	IDLE (1)		Yes	Optional (4)
98h,E5h	CHECK POWER MODE (1)		Yes	Optional (4)
99h,E6h	SLEEP (1)		Yes	Optional (4)
9Ah	Vendor specific		Reserved	Vendor specific
9Bh-9Fh	Reserved		Reserved	Reserved
A0h-AFh	Reserved		Reserved	Reserved

Figure 101. Command coverage

Command Code	Command Name	Implementation for DMCA-2XXXX	ATA-3 Category
B0h	SMART FUNCTION SET	Yes	Optional - (5)
B1h-BFh	Reserved	Reserved	Reserved
C0h-C3h	Vendor specific	Reserved	Vendor specific
C4h	READ MULTIPLE	Yes	Optional
C5h	WRITE MULTIPLE	Yes	Optional
C6h	SET MULTIPLE MODE	Yes	Optional
C7h	Reserved	Reserved	Reserved
C8h	READ DMA (w/ retry)	Yes	Optional
C9h	READ DMA (w/o retry)	Yes	Optional
CAh	WRITE DMA (w/ retry)	Yes	Optional
CBh	WRITE DMA (w/o retry)	Yes	Optional
CCh-CFh	Reserved	Reserved	Reserved
D0h-DAh	Reserved	Reserved	Reserved
DBh	ACKNOWLEDGE MEDIA CHANGE	No	Optional - (7)
DCh	BOOT - POST-BOOT	No	Optional - (7)
DDh	BOOT - PRE-BOOT	No	Optional - (7)
DEh	DOOR LOCK	No	Optional - (7)
DFh	DOOR UNLOCK	No	Optional - (7)
E0h,94h	STANDBY IMMEDIATE (1)	Yes	Optional - (4)
E1h,95h	IDLE IMMEDIATE (1)	Yes	Optional - (4)
E2h,96h	STANDBY (1)	Yes	Optional - (4)
E3h,97h	IDLE (1)	Yes	Optional - (4)
E4h	READ BUFFER	Yes	Optional
E5h,98h	CHECK POWER MODE (1)	Yes	Optional - (4)
E6h,99h	SLEEP (1)	Yes	Optional - (4)
E7h	Reserved	Reserved	Reserved
E8h	WRITE BUFFER	Yes	Optional
E9h	WRITE SAME	No	Optional
EAh-EBh	Reserved	Reserved	Reserved
ECh	IDENTIFY DEVICE	Yes	Mandatory
EDh	MEDIA EJECT	No	Optional - (7)
EEh	IDENTIFY DEVICE DMA	Yes	Optional
EFh	SET FEATURES	Yes	Optional
F0h	Vendor specific	Reserved	Vendor specific
F1h	SECURITY SET PASSWORD	Yes	Optional - (6)
F2h	SECURITY UNLOCK	Yes	Optional - (6)
F3h	SECURITY ERASE PREPARE	Yes	Optional - (6)
F4h	SECURITY ERASE UNIT	Yes	Optional - (6)
F5h	SECURITY FREEZE LOCK	Yes	Optional - (6)
F6h	SECURITY DISABLE PASSWORD	Yes	Optional - (6)
F7h	FORMAT UNIT	Vendor specific	Vendor specific
F8h	READ NATIVE MAX LBA/CYL (3)	Vendor specific	Vendor specific
F9h	SET MAX LBA/CYL (3)	Vendor specific	Vendor specific
FAh-FFh	Vendor specific	Reserved	Vendor specific

Figure 102. Command coverage --- Continued ---

- Note:(1) These commands have two command codes and appear in this table twice, once for each command code.
- (2) The WRITE VERIFY command implemented vendor specific. The operation is same as WRITE SECTORS and verification is not performed.
  - (3) Vendor specific command F8h and F9h are used for PROTECTED AREA FEATURE.
  - (4) Power Management Feature Set
  - (5) S.M.A.R.T. Function Set
  - (6) Security Mode Feature Set
  - (7) Removable

Figure 103. Command coverage --- Continued ---

## 14.2 SET FEATURES Command Support Coverage

Following table is provided to facilitate the understanding of &Crescendo./DMCA-2xxxx "Set Features" command support coverage comparing to the ATA-3 defined command set. The column of 'Implementation' shows the capability of &Crescendo./DMCA-2xxxx for those commands. For detail operation, refer to 12.25, "Set Features (EFh)" on page 121.

Features Register	Features Name	Implementation for DMCA-2XXXX	ATA-3 Category
01h	Enable 8 bit data transfers	No	Optional
02h	Enable write cache	Yes	Vendor specific
03h	Set transfer mode	Yes	Optional
04h	Enable all auto reassignment	No	Vendor specific
33h	Disable retry	No	Vendor specific
44h	Set vendor specific bytes ECC	Yes	Optional
54h	Set cache segments	No	Vendor specific
55h	Disable read look-ahead feature	Yes	Optional
66h	Disable reverting to power on defaults	Yes	Optional
77h	Disable ECC	No	Vendor specific
81h	Disable 8 bit data transfers	No	Optional
82h	Disable write cache	Yes	Vendor specific
84h	Disable all auto reassignment	No	Vendor specific
88h	Enable ECC	No	Vendor specific
99h	Enable retries	No	Vendor specific
9Ah	Set device maximum average current	No	Optional
AAh	Enable read look-ahead feature	Yes	Optional
ABh	Set maximum prefetch	No	Vendor specific
BBh	Set 4 bytes ECC	Yes	Optional
CCh	Enable reverting to power on defaults	Yes	Optional
others	Reserved	Reserved	Reserved

Figure 104. SET FEATURES Command coverage

---

## **14.3 Changed Points from DSOA-2xxxx**

DMCA-2xxxx changed some features from DSOA-2xxxx. The changed points are described below.

### **14.3.1 Added Points**

- None

### **14.3.2 Changed Points**

- Hard Reset handling under write cashe operation
- Security Mode Feature Set (Vendor Specific - > ATA-3 standard)
- Identify device information
- Master Password default strings

### **14.3.3 Deleted Points**

- None



# Index

## A

ABRT 50  
ABT 50  
Adaptive Power Management Feature 60  
    Low Power (LP) Idle mode 60  
    Performance Idle mode 60  
    Transition Time 60  
AMN 51  
AMNF 51  
Auto Reassign Function 71  
    Non recovered read errors 71  
    Non recovered write errors 71  
    Recovered read errors 71  
Automatic Power Down Sequence 140

## B

B 82  
BBK 50  
BSY 52

## C

Changed Points from DSOA-2xxxx (SONATA) 161  
Check Power Mode 76, 83  
Command  
    Check Power Mode (E5h/98h) 83  
    Execute Device Diagnostic (90h) 84  
    Format Track (50h) 85  
    Format Unit (F7h) 88  
    Identify Device (ECh) 89  
    Identify Device DMA (EEh) 93  
    Idle (E3h/97h) 94  
    Idle Immediate (E1h/95h) 95  
    Initialize Device Parameters (91h) 96  
    Read Buffer (E4h) 97  
    Read DMA (C8h/C9h) 98  
    Read Long (22h/23h) 100  
    Read Multiple (C4h) 102  
    Read Native Max LBA/CYL (F8h) 104  
    Read Sectors (20h/21h) 106  
    Read Verify Sectors (40h/41h) 108  
    Recalibrate (1xh) 110  
    S.M.A.R.T. Function Set (B0h) 127  
    Security Disable Password (F6h) 111  
    Security Erase Prepare (F3h) 112  
    Security Erase Unit (F4h) 113  
    Security Freeze Lock (F5h) 115  
    Security Set Password (F1h) 116  
    Security Unlock (F2h) 118  
    Seek (7xh) 120  
    Set Features (EFh) 121  
    Set Max LBA/CYL (F9h) 123  
    Set Multiple (C6h) 125

## Command (continued)

Sleep (E6h/99h) 126  
Standby (E2h/96h) 140  
Standby Immediate (E0h/94h) 141  
Write Buffer (E8h) 142  
Write DMA (CAh/CBh) 143  
Write Long (32h/33h) 145  
Write Multiple (C5h) 147  
Write Sectors (30h/31h) 149  
Write Verify (3Ch) 151  
Commands support Coverage 157  
COR 52  
CORR 52

## D

D 82  
DF 52  
Diagnostic  
    Diagnostic and Reset considerations 56  
Diagnostic and Reset considerations 56  
Diagnostic Codes 50, 55, 84  
DRDY 52  
DRQ 52  
DRV 50  
DS0 49  
DS1 49  
DSC 52

## E

ERR 52  
Error Register  
    Diagnostic Codes 55  
Example of operation 69  
Execute Device Diagnostic 76, 84

## F

Format Track 74, 85  
Format Unit 76, 88

## H

H 82  
H0 49  
H1 49  
H2 49  
H3 49  
HS0 50  
HS1 50  
HS2 50  
HS3 50

## I

Identify Device 73, 89  
Identify Device DMA 77, 93  
Idle 76, 94  
Idle Immediate 76, 95  
IDN 50  
IDNF 50  
IDX 52  
IEN 49  
Initial Power Mode at Power On 59  
Initialize Device Parameters 76, 96

## L

L 50, 82  
LBA Addressing Mode 57  
Logical CHS Addressing Mode 57

## M

Master 50

## P

Power Management Feature 58  
    Initial Power Mode at Power On 59  
    Interface Capability for Power Modes 59  
    Power Management Commands 58  
    Power Mode 58  
    Standby timer 59  
    Standby/Sleep command completion timing 58  
    Status 59

## R

R 82  
RDY 52  
Read Buffer 73, 97  
Read DMA 77, 98  
Read Long 73, 100  
Read Multiple 73, 102  
Read Native Max LBA/CYL 76, 104  
Read Sectors 73, 106  
Read Verify Sectors 76, 108  
Reassign Function 71  
Recalibrate 76, 110  
Register  
    Alternate Status Register 47  
    Command Register 48  
    Cylinder High Register 48  
    Cylinder Low Register 48  
    Data Register 48  
    Device Control Register 48  
    Device/Head Register 49  
    Drive Address Register 49  
    Error Register 50  
    Features Register 51  
    Register Initialization 55

Register (*continued*)

    Sector Count Register 51  
    Sector Number Register 51  
    Status Register 51  
Register Initialization 55  
Reset  
    Diagnostic and Reset considerations 56  
    Register Initialization 55  
RST 49

## S

S.M.A.R.T. Function 61  
    Attribute thresholds 61  
    Attribute values 61  
    Attributes 61  
    S.M.A.R.T. commands 61  
    S.M.A.R.T. operation with power management modes 61  
    Threshold exceeded condition 61  
S.M.A.R.T. Function Set 127  
Sector Addressing Mode 57  
    LBA Addressing Mode 57  
    Logical CHS Addressing Mode 57  
Security Disable Password 74, 111  
Security Erase Prepare 76, 112  
Security Erase Unit 74, 113  
Security Freeze Lock 76, 115  
Security Mode Feature Set 63  
Security Set Password 74, 116  
Security Unlock 74, 118  
Seek 76, 120  
Set Features 76, 121  
SET FEATURES Command support Coverage 160  
Set Max LBA/CYL 76, 123  
Set Multiple 125  
Set Multiple Mode 76  
Slave 50  
Sleep 76, 126  
SMART Disable Operations 76  
SMART Enable Operations 76  
SMART Enable/Disable Attribute Autosave 76  
SMART Execute Off-line Data Collection 76  
SMART Read Attribute Thresholds 73  
SMART Read Attribute Values 73  
SMART Return Status 76  
SMART Save Attribute Values 76  
SRST 49  
Standby 76, 140  
Standby Immediate 76, 141

## T

T0N 50  
Timeout Interval 49, 153  
Timeout Parameter 94, 140  
TK0NF 50

## **U**

UNC 50

## **V**

V 82

## **W**

Write Buffer 74, 142

Write Cache 70

Write DMA 77, 143

Write Long 74, 145

Write Multiple 74, 147

Write Sectors 74, 149

Write Verify 75, 151

WTG 49

## **X**

x 82



S46H-6807-04