



**ULTRASTAR 9LZX/18ZX  
Hardware/Functional Specification  
9.1/18.2 GB Models, 10020 RPM  
LVD SCSI Version 2.40**

Document Number AS21-0223-00

December 11, 1998

## I. Preface

This document details the Hardware/Functional Specifications for the ULTRASTAR 9LZX/18ZX High Capacity Family of 3.5-inch Disk Drives.

The product description and other data found in this document represent IBM's design objectives and is provided for information and comparative purposes. Actual results may vary based on a variety of factors and the information herein is subject to change. **THIS PRODUCT DATA DOES NOT CONSTITUTE A WARRANTY, EXPRESS OR IMPLIED.** Questions regarding IBM's warranty terms or the methodology used to derive the data should be referred to your IBM representative.

### i. Revision Codes and Dates Applied

Following is a list of dates that revisions have been applied.

Version	Date	Change
2.4	12/11/98	LA level specification

### ii. Reviewers

The following areas are responsible for reviewing the accuracy of this specification. The review is documented by a note from each functional area manager and is kept in the program project file.

- Development Manager
- Mechanical Design Manager
- Servo Architecture Manager
- Interface Microcode Manager
- PAE Manager
- Component Integration Manager
- Mechanical Integration Manager
- Card/Electronics Manager:
- Product Assurance Manager
- RAS Manager

### iii. Approvers

Approval for this document is the responsibility of the Program Manager. The approval is documented by a note from the Program manager and is kept in the program project file.

### iv. Trademarks

IBM, No-ID, and Predictive Failure Analysis are trademarks of International Business Machines Corporation in the United States and/or other countries.

### v. Hard Disk Drive (HDD) Website

Visit IBM's Hard Disk Drive (HDD) website at <http://www.storage.ibm.com/hardsoft/diskdrdl.htm> for more information on IBM's products, technology and technical support.

---

## Table Of Contents

I. Preface .....	2
Table Of Contents .....	3
List of Figures .....	6
List of Tables .....	7
1 Description .....	8
1.1 Features .....	8
1.2 Models .....	10
2 Specifications .....	11
2.1 General .....	11
2.2 Notch Details .....	12
2.3 Capacities by Format Length .....	12
2.4 Power Requirements .....	13
2.4.1 Specifications .....	13
2.4.2 RMS Power Measurements .....	14
2.4.3 Power Supply Graphs .....	15
2.4.4 Power Supply Ripple .....	19
2.4.5 Power Supply Common Mode Noise .....	19
2.4.6 Input Capacitance .....	19
2.4.7 Grounding Requirements of the Disk Enclosure .....	19
2.4.8 'Hot Plug/Unplug' Support .....	19
2.5 Bring-up Sequence (and Stop) Times .....	21
2.5.1 Spin Down Times .....	21
3 Performance .....	23
3.1 Environment Definition .....	23
3.2 Workload Definition .....	23
3.2.1 Sequential .....	23
3.2.2 Random .....	23
3.3 Command Execution Time .....	24
3.3.1 Basic Component Descriptions .....	28
3.3.2 Comments .....	31
3.4 Disconnection During Read/Write Data Phase .....	31
3.5 Approximating Performance for Different Environments .....	32
3.5.1 When Read Caching is Enabled .....	32
3.5.2 When Read Ahead is Enabled .....	32
3.5.3 When Write Caching is Enabled .....	32
3.5.4 When Adaptive Caching is Enabled .....	33
3.5.5 For Queued Commands .....	33
3.5.6 Reordered Commands .....	33
3.5.7 Back-To-Back Write Commands .....	33
3.6 Read Command Performance .....	33
3.6.1 SCSI Bus Overhead .....	34
3.6.2 Command Execution Overhead .....	34
3.7 Write Command Performance .....	34
3.7.1 SCSI Bus Overhead .....	35
3.7.2 Command Execution Overhead .....	35
3.8 Skew .....	35
3.8.1 Cylinder to Cylinder Skew .....	35
3.8.2 Track to Track Skew .....	35
3.9 Idle Time Functions .....	36

3.9.1 Predictive Failure Analysis	36
3.9.2 Save Logs and Pointers	37
3.9.3 Disk Sweep	37
3.9.4 Summary	37
3.10 Temperature Monitoring	37
3.11 Command Timeout Limits	38
3.11.1 Reassignment Time	38
3.11.2 Format Time	38
3.11.3 Start/Stop Unit Time	38
3.11.4 Medium Access Command Time	38
3.11.5 Timeout Limits for Other Commands	39
4 Mechanical	40
4.1 Weight and Dimensions	40
4.2 Clearances	40
4.3 Mounting Guidelines	40
4.3.1 SCA-2 Mounting Guidelines	41
4.4 Mounting Drawings	41
4.4.1 Side Mounts (All)	41
4.4.2 68 Pin SCSI Bottom Mounts	42
4.4.3 80 Pin SCA-2 SCSI Bottom Mounts	43
4.5 Electrical Connectors	43
4.5.1 68 Pin SCSI	43
4.5.2 80 Pin SCSI	44
4.5.3 Jumper Pins	44
5 Electrical Interface	45
5.1 Power Connector	45
5.2 SCSI Bus Connector	45
5.2.1 68 Pin Signal Connector	45
5.2.2 80 Pin (Single Connector Attachment) Connector	47
5.2.3 SCSI Bus Cable	49
5.2.4 SCSI Bus Terminators	49
5.2.5 SCSI Bus Termination Power	50
5.2.6 Single-ended SCSI Bus Electrical Characteristics	50
5.2.7 Low Voltage Differential SCSI Bus Electrical Characteristics	50
5.3 Option Block Connector (Jumper Blocks)	53
5.3.1 68 Pin Auxiliary Connector	55
5.3.2 SCSI ID (Address) Pins	56
5.3.3 Auto Start (and Delay) Pins	56
5.3.4 External Activity (LED) Pins	57
5.3.5 Write Protect Pin	57
5.3.6 Disable Synchronous Negotiation Pin	58
5.3.7 Disable SCSI Parity Pin	58
5.3.8 Disable Unit Attention Pin	58
5.3.9 Disable Wide Negotiations	58
5.3.10 Force Single Ended Mode	58
6 Reliability	59
6.1 Error Detection	59
6.2 Data Reliability	59
6.3 SPQL (Shipped product quality level)	59
6.4 Failure Rate	59
6.5 Shelf Life	59
6.6 Start Stop Cycles	59
7 Operating Limits	60
7.1 Environmental	60

7.1.1 Temperature Measurement Points .....	60
7.2 Vibration and Shock .....	62
7.2.1 Output Vibration Limits .....	62
7.2.2 Operating Vibration .....	62
7.2.3 Nonoperating Vibration .....	63
7.2.4 Operating Shock .....	63
7.2.5 Nonoperating Shock .....	64
7.3 Contaminants .....	64
7.4 Acoustic Levels .....	64
7.5 Drive Mounting Guidelines .....	65
7.6 Drive/System Compatibility .....	65
7.7 Recommendations for Handling of Disk Drives .....	67
7.8 Breather Filter Hole .....	68
7.9 Periodic Maintenance .....	68
7.10 ESD Protection and Handling .....	68
7.11 Stray Magnetic Fields .....	68
8 Standards .....	69
8.1 Safety .....	69
8.2 Electromagnetic Compatibility (EMC) .....	70

---

## List of Figures

Fig 1. Ultrastar 9LZX Disk Drive Assembly .....	8
Fig 2. Typical 12V seek profile (Ultrastar 9LZX) .....	15
Fig 3. Typical 12V seek profile (Ultrastar 18ZX) .....	16
Fig 4. Typical 5V write current profile (Ultrastar 9LZX and Ultrastar 18ZX) .....	16
Fig 5. Typical 5V read current profile (Ultrastar 9LZX and Ultrastar 18ZX) .....	17
Fig 6. Typical 12V start current profile (Ultrastar 9LZX) .....	17
Fig 7. Typical 12V start current profile (Ultrastar 18ZX) .....	18
Fig 8. Typical 5V start current profile (Ultrastar 9LZX and Ultrastar 18ZX) .....	18
Fig 9. Start Time Diagram .....	21
Fig 10. Ultrastar 9LZX with no caching or queuing .....	24
Fig 11. Ultrastar 9LZX random reads and writes with and without reordering .....	25
Fig 12. Ultrastar 9LZX queued sequential performance .....	25
Fig 13. Ultrastar 9LZX with Write Cache on and Read Cache on .....	26
Fig 14. Ultrastar 18ZX with no caching or queuing .....	26
Fig 15. Ultrastar 18ZX random reads and writes with and without reordering .....	27
Fig 16. Ultrastar 18ZX queued sequential performance .....	27
Fig 17. Ultrastar 18ZX with Write Cache on and Read Cache on .....	28
Fig 18. SCSI Read command performance measurements .....	33
Fig 19. SCSI Write Command Performance Measurements .....	34
Fig 20. Location of side mounting holes of Ultrastar 9LZX. ....	41
Fig 21. Location of side mounting holes of Ultrastar 18ZX .....	42
Fig 22. Location of bottom mounting holes (68 pin SCSI version) .....	42
Fig 23. Location of bottom mounting holes (80 pin SCA-2 SCSI version) .....	43
Fig 24. 68 pin SCSI Electrical Connector .....	44
Fig 25. 80 pin SCSI Connector .....	44
Fig 26. Jumper Pins .....	44
Fig 27. 68 pin Front Option Jumper Block and TermPower Block .....	54
Fig 28. SCA-2 Front Option Jumper Block .....	54
Fig 29. Auxiliary Connector on the 68 pin Connector .....	55
Fig 30. LED Circuit Diagram .....	57
Fig 31. Temperature Measurement Points (bottom view) .....	61
Fig 32. Temperature Measurement Point (top view) .....	62
Fig 33. Breather Hole for Filter .....	68

---

## List of Tables

Table 1. Available Models .....	10
Table 2. Notch capacities .....	12
Table 3. Available user blocks .....	12
Table 4. Available user bytes .....	13
Table 5. Ultrastar 9LZX Power Supply Currents .....	13
Table 6. Ultrastar 18ZX Power Supply Currents .....	14
Table 7. RMS Power Measurements .....	14
Table 8. Bring-up Sequence Times .....	21
Table 9. Overhead Values (milliseconds) .....	29
Table 10. Data Sector Transfer Rates (MB/s) .....	30
Table 11. Summary of Idle Time Functions .....	37
Table 14. 68 Pin LVD and SE SCSI Connector Contact Assignments .....	46
Table 15. 80 Pin SCA-2 LVD and SE Connector Contact Assignments .....	48
Table 16. LVD Terminators .....	49
Table 17. Single-Ended Bus Electrical Characteristics .....	50
Table 18. LVD SCSI Controller to SCSI Connector Stub Length .....	50
Table 19. LVD SCSI Controller Single-Ended Capacitive Load Data .....	51
Table 20. LVD SCSI Controller Differential Capacitive Load Data .....	51
Table 21. LVD SCSI Controller Single-Ended Slew Rate Data .....	51
Table 22. LVD SCSI Controller Differential Slew Rate Data .....	52
Table 23. LVD SCSI Controller Single-Ended Assertion/Negation Data .....	52
Table 24. LVD SCSI Controller Differential Assertion/Negation Data .....	52
Table 25. LVD SCSI Controller Single-Ended Setup and Hold Time Data .....	52
Table 26. LVD SCSI Controller Differential Setup and Hold Time Data .....	52
Table 27. LVD SCSI Controller Single-Ended Hysteresis Data .....	53
Table 28. Address Determination of 68 and 80 Pin Models .....	56
Table 29. Auto-Startup Modes selectable by Auto-Start/Delay Pin Combinations (68 pin) .....	56
Table 30. Auto-Startup Modes selectable by Auto-Start/Delay Pin Combinations (80 pin) .....	57
Table 31. Absolute Maximum and Recommended Maximum Operating Case Temperature Limits .....	61
Table 32. Random Vibration Levels (Operating) .....	63
Table 33. Random Vibration Levels (Nonoperating) .....	63
Table 34. Swept Sine Vibration Levels .....	63
Table 36. Stray Magnetic Field Strength .....	68

---

## 1 Description

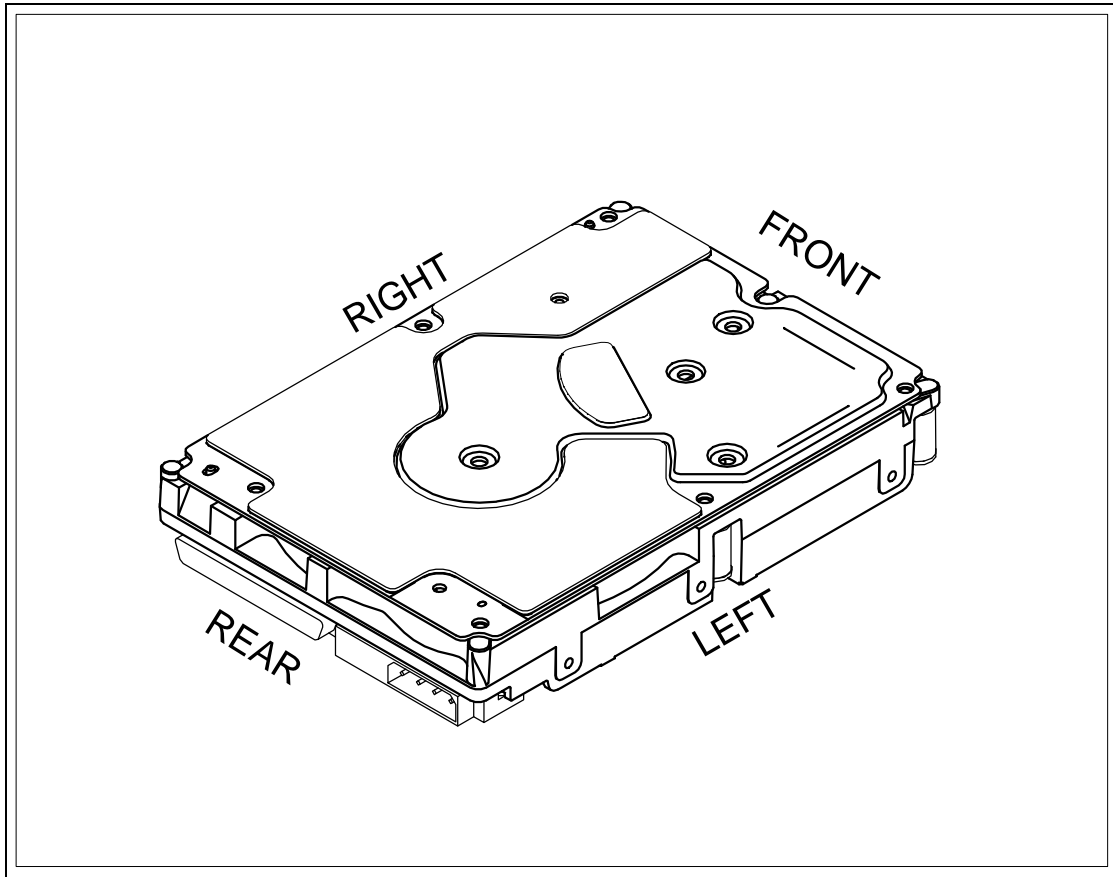

Fig 1. Ultrastar 9LZX Disk Drive Assembly

---

### 1.1 Features

#### General Features

- 9.1 GB/18.2 GB (512 bytes/sector)
- Industry-standard interface:
  - Low Voltage Differential SCA-2/80 pin and 68 pin
- Rotary voice coil motor actuator
- Closed-loop digital actuator servo
- Embedded sector servo
- Magnetoresistive (MR) heads
- 16/17 rate encoding
- Partial Response Maximum Likelihood (PRML) data channel with analog filter
- No-ID™ sector format
- All mounting orientations supported
- 4 MB segmented cache buffer
- Jumperable drive supplied terminator power (on some models)
- LED Driver
- Bezel (Optional on some models)

**Performance Summary**

- Average read seek time Ultrastar 9LZX: 5.3 milliseconds
- Average read seek time Ultrastar 18ZX: 6.5 milliseconds
- Average Latency: 2.99 milliseconds
- Sustained data transfer rate: 15.2 to 20.3 MegaBytes/second (16 notches)
- Peak media transfer rate: 23.4 to 30.5 MegaBytes/second (16 notches)
- Ultra2 SCSI data transfer rate: 40 MegaTransfers/second (sustained synchronous)
- SCSI bus overhead: < 40 microseconds
- Read command overhead: < 350 microseconds

**SCSI Interface Controller Features**

- Multiple initiator support
- Variable logical block lengths (512 - 732 supported)<sup>1</sup>
- Nearly Contiguous Read
- Read-ahead caching
- Adaptive caching algorithm
- Rotational Positioning Optimization
- Write Caching
- Back-to back writes (merged writes)
- Tagged and untagged command queuing
- Command reordering (4 user selectable algorithms)
- Automatic retry and data correction on read errors
- Automatic sector reallocation
- In-line alternate sector assignment for high-performance
- Down-loadable firmware
- Customizing controller jumpers, for example:-
  - Auto spindle motor start
  - Auto start delay
  - Disable Target Initiated Synchronous Negotiation
  - Disable Unit Attention
  - Disable SCSI Parity
  - Write protection

**Reliability Features**

- Self-diagnostics on power up
- Dedicated head landing zone
- Magnetic actuator latch
- Entire Read/Write data path protected by a 32 Bit CRC
- 24 Byte Error Correcting Code (ECC)
- 9 Byte ECC on the fly
- Predictive Failure Analysis™ (PFA)™
- Error Recovery Procedures (ERP)
- Data Recovery Procedures (DRP)
- Probability of not recovering data: **10 in 10<sup>15</sup>** bits read
- Event logging and analysis
- Drive-Temperature Indicator Processor (Drive-TIP)™ Temperature monitoring and logging

---

<sup>1</sup> Please see “Capacities by Format Length” on page 13 for more details.

---

## 1.2 Models

The Ultrastar 9LZX/18ZX disk drive is available in various models with a variety of the following options.

- Capacity of 9.1 GB or 18.2 GB  
Please refer to section 2.3, “Capacities by Format Length” for exact capacities based on user block size.
- Physical connectors available
  - 68 pin SCSI connector models offer an 8/16 bit SCSI bus using the SCSI ‘P’ connector which supports Wide data transfers.
  - 80 pin SCSI connector models offer an 8/16 bit SCSI bus using the ‘SCA-2’ connector.

Capacity	Model	SCSI Pins/Connector Type	SCSI Electrical Signal Type
9.1 GB	DRVS-09V	68/Unitized Connector	Low Voltage Differential (Ultra 2)
9.1 GB	DRVS-09D	80 SCA-2	Low Voltage Differential (Ultra 2)
18.2 GB	DRVS-18V	68/Unitized Connector	Low Voltage Differential (Ultra 2)
18.2 GB	DRVS-18D	80 SCA-2	Low Voltage Differential (Ultra 2)

Table 1. Available Models

## 2 Specifications

All specification numbers are mean population values unless otherwise noted.

### 2.1 General

**Note:** The recording band located nearest the disk outer diameter (OD) is referred to as 'Notch #1', the recording band located nearest the inner diameter (ID) is called 'Notch #16'. Throughout this document 1 MB refers to 1,000,000 bytes and 1 GB refers to 1,000,000,000 bytes.

#### Data transfer rates

	Notch #16	Notch #1	
<b>Buffer to/from media</b>	23.4	30.5	MB/s instantaneous
<b>Host to/from buffer</b>	15.2	20.3	MB/s sustained
	up to 40.0 MB/s (synchronous - Ultra)		
	up to 80.0 MB/s (synchronous - Ultra2)		

**Rotational speed** 10,020 RPM

**Average Latency** 2.99 ms

**Track density** 9240 TPI

	Minimum	Maximum
<b>Recording density</b>	146 kbp	219.1 kbp
<b>Areal density</b>	1353Mb/sq inch	2024 Mb/sq inch

	Ultrastar 9LZX	Ultrastar 18ZX
<b>Disks</b>	5	10
<b>Heads</b>	10	20

**Seek timing** Measured at nominal voltage and temperature

	Ultrastar 9LZX	Ultrastar 18ZX
<b>Single cylinder</b>	0.7 ms (Read)	0.7 ms (Read)
	1.5 ms (Write)	1.5 ms (Write)
<b>Average weighted</b>	5.3 ms (Read)	6.5 ms (Read)
	6.3 ms (Write)	7.5 ms (Write)
<b>Full stroke</b>	11.5 ms (Read)	13.5 ms (Read)
	13.0 ms (Write)	15.0 ms (Write)

## 2.2 Notch Details

For the following conditions

User bytes/Sector	512
Sectors/logical block	1
User bytes/logical block	512
Number of cylinders	7065

The notch table is as follows

Notch	Start Cylinder	End Cylinder	User data Cylinders	Reserved Cylinders	Data/ servo	User sectors
1	0	4,070	4058/4062 (9.1/18.2)	13/9 (9.1/18.2)	4/1	272
2	4,071	4,175	105	0	31/8	263
3	4,176	4,385	210	0	19/5	258
4	4,386	4,551	166	0	15/4	255
5	4,552	4,710	159	0	48/13	251
6	4,711	5,028	318	0	18/5	244
7	5,029	5,172	144	0	25/7	242
8	5,173	5,317	145	0	7/2	238
9	5,318	5,605	288	0	24/7	233
10	5,606	5,870	265	0	37/11	228
11	5,871	6,061	191	0	10/3	226
12	6,062	6,170	109	0	23/7	223
13	6,171	6,323	153	0	29/9	219
14	6,324	6,455	132	0	16/5	217
15	6,456	6,961	506	0	3/1	204
16	6,962	7,064	100	3	3/1	204

Table 2. Notch capacities

Allowed user bytes/Sector 512 to 732 (even byte numbers only)

## 2.3 Capacities by Format Length

For the allowable sector lengths the drive capacity is as follows

User bytes / logical block	User Logical Blocks (9.1 GB)	User Logical Blocks (18.2 GB)
512	17,928,698	35,879,135
514	17,903,728	35,829,195
520	17,453,878	34,928,695
522	17,441,768	34,904,475
524	17,333,918	34,688,615
528	17,296,088	34,612,955
536	17,078,028	34,176,515
732	12,974,088	25,963,755

Table 3. Available user blocks

User bytes / logical block	User bytes / drive (9.1 GB)	User bytes / drive (18.2 GB)
512	9,179,493,376	18,370,117,120
514	9,202,516,192	18,416,206,230
520	9,076,016,560	18,162,921,400
522	9,104,602,896	18,220,135,950
524	9,082,973,032	18,176,834,260
528	9,132,334,464	18,275,640,240
536	9,153,823,008	18,318,612,040
732	9,497,032,416	19,005,468,660

Table 4. Available user bytes

**Note:**

1. The maximum addressable LBA is User Logical Blocks -1. Minimum is 0.
2. The capacity is calculated as the User Logical Blocks multiplied by the block size.

---

## 2.4 Power Requirements

### 2.4.1 Specifications

The following voltage specifications apply at the drive power connector. There is no special power on/off sequencing required.

#### Input Voltage

+5 V	5 V ( $\pm 5\%$ during run and spin-up)
+12 V	12 V ( $\pm 5\%$ during run, $+5\%/-7\%$ during spin-up <sup>2</sup> )

#### Power Supply On/Off Requirements

+5 V	4.5 V/sec Minimum slew
+12 V	7.4 V/sec Minimum slew

#### Power Supply Current

Ultrastar 9LZX		Population Max.	Population Mean	Population Range
+5 V DC (Power Save mode <sup>3</sup> )			0.55 A <sup>4</sup>	+/- 10%
+5 V DC (Idle)			0.76 A	+/- 10%
+5 V DC (R/W baseline)	Typical		0.80 A	+/- 10%
+5 V DC (R/W pulse)	Peak	1.30 A		+/- 10%
+12 V DC (Power Save mode)			0.62 A	+/- 10%
+12 V DC (Idle)			0.66 A	+/- 10%
+12 V DC (Seek peak)	Peak	2.1 A		Maximum
+12 V DC (Start)	Maximum	2.0 A <sup>5</sup>		Maximum

<sup>2</sup>Spin-up defined as time within 10 seconds after a unit start.

<sup>3</sup>Power Save mode is automatically invoked after 1 second of inactivity, except when read ahead is active, in which case Power Save mode is invoked after 40 seconds of inactivity.

<sup>4</sup>5 V current is given with termination power provided by the using system if required.

<sup>5</sup> The start current is the total 12 V current required by the drive.

Table 5. Ultrastar 9LZX Power Supply Currents

Ultrastar 18ZX		Population Max	Population Mean	Population Range
+5 V DC (Power Save mode)			0.55 A <sup>6</sup>	+/- 10%
+5 V DC (Idle)			0.76 A	+/- 10%
+5 V DC (R/W baseline)	Typical		0.80 A	+/- 10%
+5 V DC (R/W pulse)	Peak	1.30 A		+/- 10%
+12 V DC (Power Save mode)			1.13 A	+/- 10%
+12 V DC (Idle)			1.18 A	+/- 10%
+12 V DC (Seek peak)	Peak	2.7 A		Maximum
+12 V DC (Start)	Maximum	3.50 A		Maximum

Table 6. Ultrastar 18ZX Power Supply Currents

Energy Consumption

Ultrastar 9LZX	0.0011	watts/MB
Ultrastar 18ZX	0.0009	watts/MB

## 2.4.2 RMS Power Measurements

	Population mean Ultrastar 9LZX	Population mean Ultrastar 18ZX
Power Save	10.12 Watts	16.33 Watts
Idle	11.19 Watts	17.72 Watts
15 ops/second	12.14 Watts	18.55 Watts
30 ops/second	13.25 Watts	19.49 Watts
60 ops/second	15.11 Watts	21.45Watts
90 ops/second	16.25 Watts	22.75 Watts

Table 7. RMS Power Measurements

### Notes:

1. Idle measurements assume a 30 minute warm-up time and track following on cylinder 0.
2. For these non-idle measurements an op is defined as a read transfer of 4k Bytes over a random distribution of LBAs across the drive.
3. Power Measurements made using Clarke Hess Model 259 Digital Wattmeter
4. For the purpose of calculations 0.058 Watts per op for the Ultrastar 9LZX and 0.057 Watts per op for the Ultrastar 18ZX can be used. This is not completely accurate because of the non linear scale but can be used for approximations.

Example

If power was required for 120 ops per second the calculation would be as follows for the Ultrastar 9LZX:

Idle power = 11.19 Watts

120 ops/second = 120 \* 0.058 = 6.96 Watts

<sup>6</sup> 5 V current is given with termination power provided by the using system if required.

$$\text{Total Power} = 11.19 + 6.96 = 18.15 \text{ Watts}$$

### 2.4.3 Power Supply Graphs

These graphs are actual traces recorded on real drives in a lab environment. They are intended to be typical examples and do not show worst case conditions.

All power supplies are nominal.

The results exclude inductive spikes caused by leads, power supplies and components that will vary with different setup configurations.

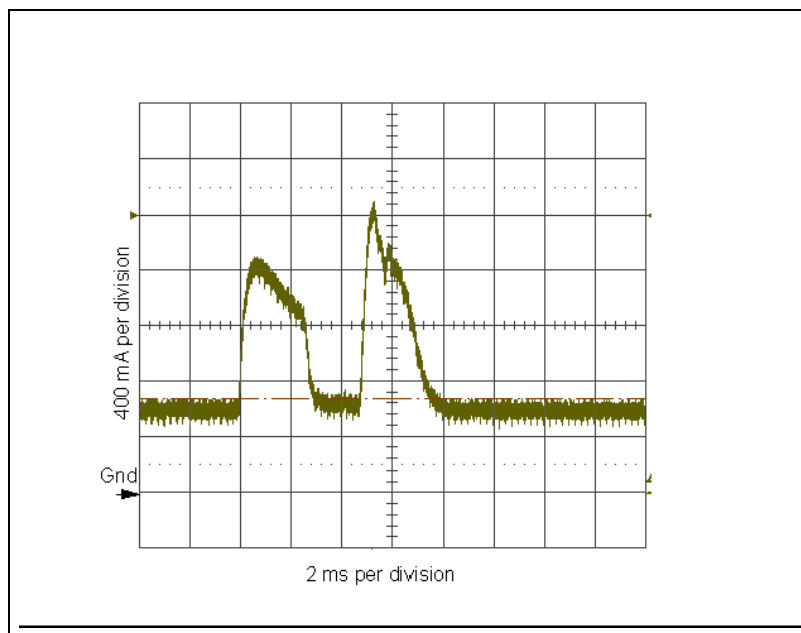

Fig 2. Typical 12V seek profile (Ultrastar 9LZX)

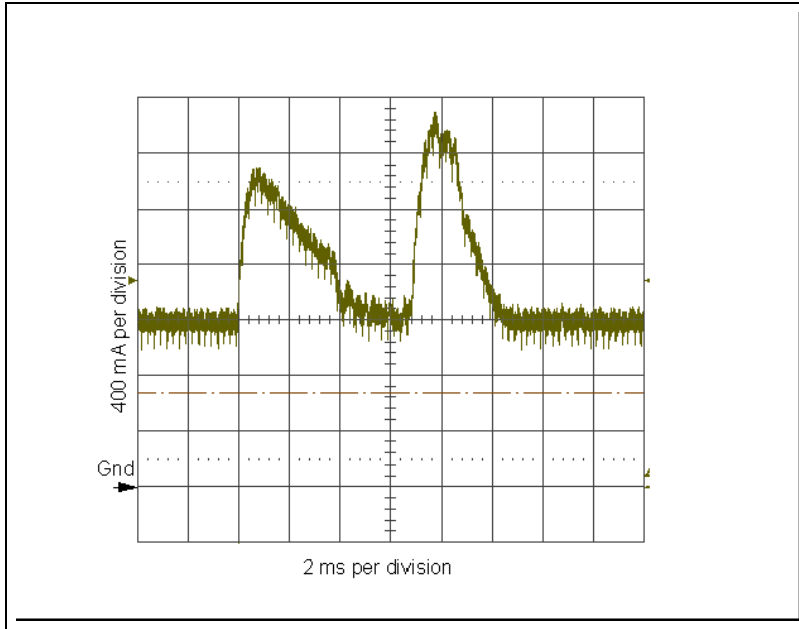

Fig 3. Typical 12V seek profile (Ultrastar 18ZX)

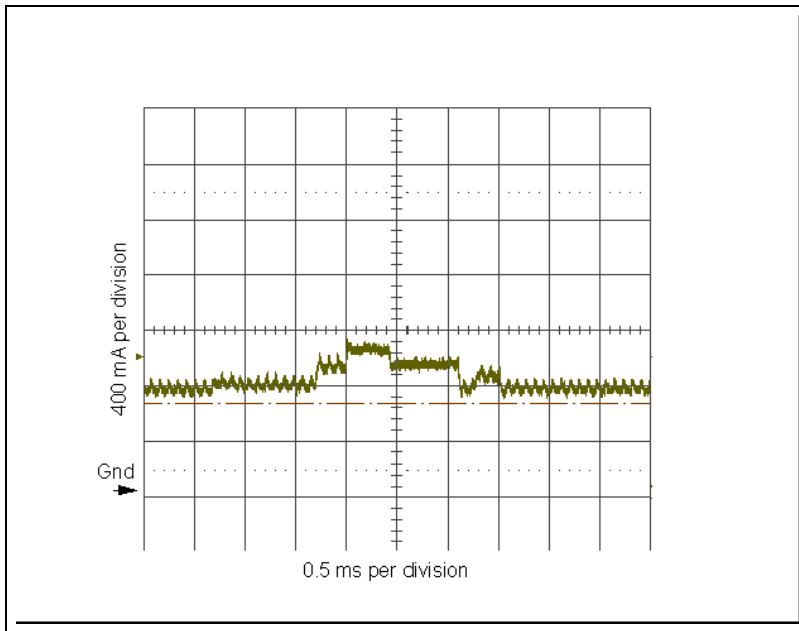

Fig 4. Typical 5V write current profile (Ultrastar 9LZX and Ultrastar 18ZX)

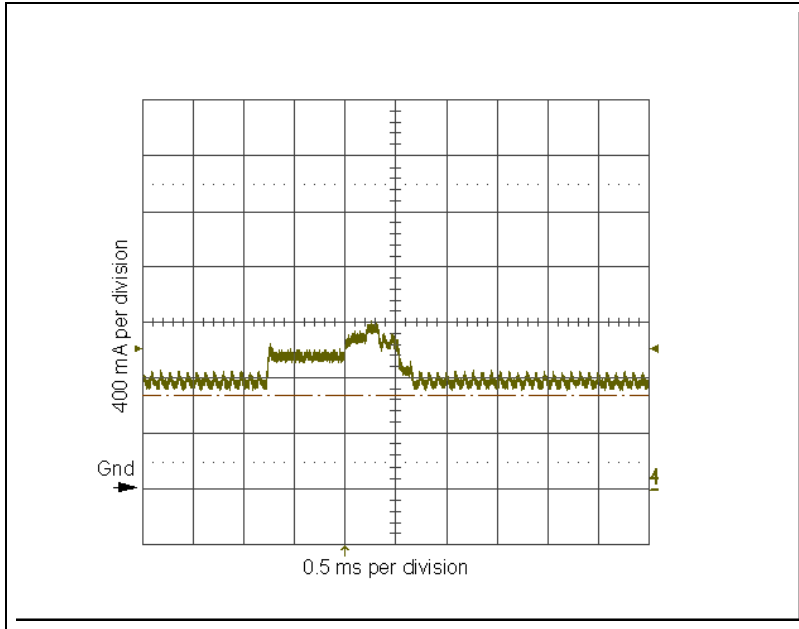

Fig 5. Typical 5V read current profile (Ultrastar 9LZX and Ultrastar 18ZX)

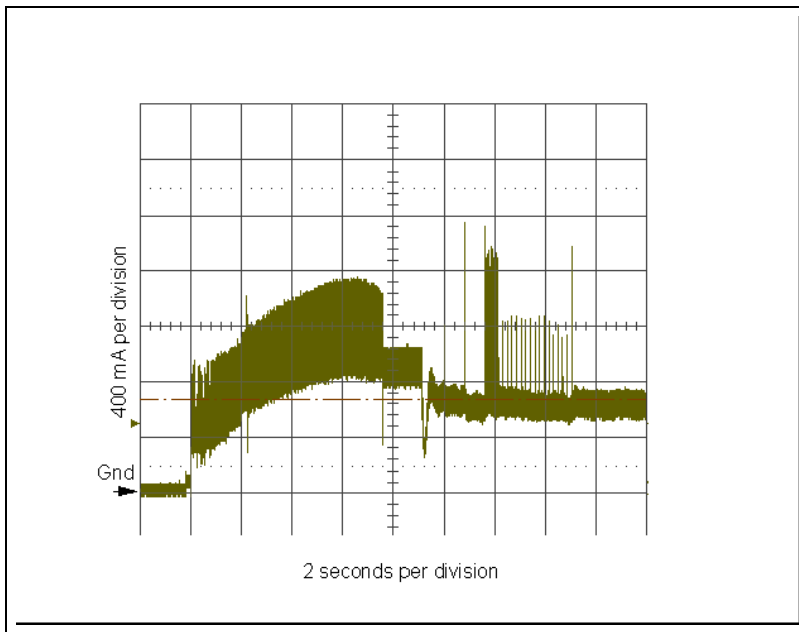

Fig 6. Typical 12V start current profile (Ultrastar 9LZX)

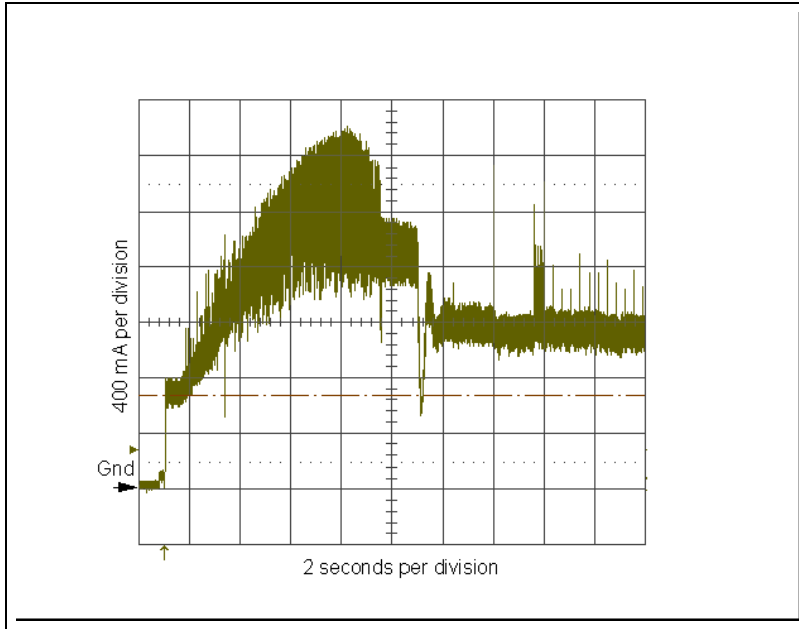

Fig 7. Typical 12V start current profile (Ultrastar 18ZX)

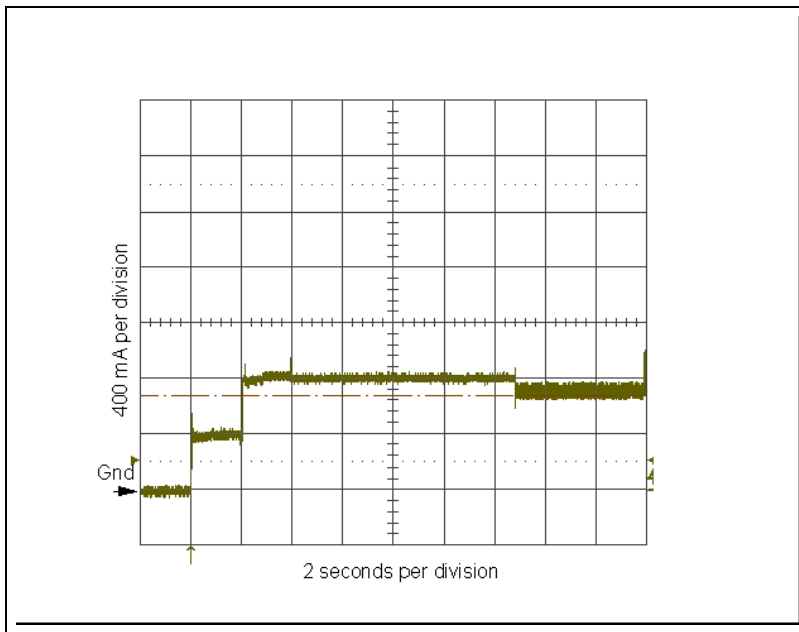

Fig 8. Typical 5V start current profile (Ultrastar 9LZX and Ultrastar 18ZX)

## 2.4.4 Power Supply Ripple

### Externally Generated Ripple as seen at drive power connector

	Maximum	Frequency
+5 V DC	250 mV P-to-P	0-20 MHz
+12 V DC	650 mV P-to-P	0-100 Hz
	400 mV P-to-P	100-5,000 Hz
	250 mV P-to-P	5 KHz- 20 MHz

During drive start up and seeking, 12 volt ripple is generated by the drive (referred to as dynamic loading). If several drives have their power daisy chained together then the power supply ripple plus other drives' dynamic loading must remain within the regulation tolerance window of +/- 5%. A common supply with separate power leads to each drive is a more desirable method of power distribution.

## 2.4.5 Power Supply Common Mode Noise

The drive is sensitive to common mode noise on the power supply cable. Common mode noise current on the power supply cable should not exceed 20 mA (150 kHz to 230 MHz)

## 2.4.6 Input Capacitance

Internal bulk capacitance as seen at drive power connector

+5 V DC	72 $\mu$ F +/- 20%
+12 V DC	510 $\mu$ F +/- 20%

## 2.4.7 Grounding Requirements of the Disk Enclosure

The disk enclosure is at Power Supply ground potential.

From an ElectroMagnetic Compatibility (EMC) standpoint it will, in most cases be preferable to provide a common ground connection between the disk enclosure and the system's mounting frame. With this in mind, it is important that the Disk Enclosure not become an excessive return current path from the system frame to power supply. The drive's mounting frame must be within +/- 150 millivolts of the drive's power supply ground. At no time should more than 20 milliamps of current (0 to 230Mhz) be injected into the disk enclosure.

## 2.4.8 'Hot Plug/Unplug' Support

The term 'Hot Plug', refers to the action of mechanically engaging a device to power and / or SCSI bus when other devices may be active on the same bus.

A comprehensive classification of the state of the SCSI bus during this event is located in the SCSI-3 Parallel Interface Standard.

### Note:

- Case 3 is defined as 'Current I/O processes not allowed during insertion or removal'
- Case 4 is defined as 'Current I/O processes allowed during insertion or removal'

While every effort was made to design the drive not to influence the SCSI bus during these events, it is a system responsibility to insure voltage regulation and conformance to operational and non-operational shock limits.

During Hot unplug events the operational shock levels should not be exceeded. The operational shock levels of adjacent drives should not be exceeded as well. The recommended procedure is to prohibit write operations to adjacent drives during the HOT PLUG and during the HOT UNPLUG actions. If this cannot be guaranteed then the drive should be issued a SCSI Stop Unit command that is allowed to complete before unplugging. The basic requirement is that while the drive is operational or spinning down (as a result of a UNIT STOP or Unplug) the operational shock limits are in effect. Once the drive has completely stopped (20 seconds max) the non-operational shock limits are in effect. The recommended procedure is to allow the unplugged drive to rest in the drive bay for a minimum of 20 seconds and then complete the removal.

During Hot Plug or Unplug events the power supply ripple on adjacent operational drives should not go outside of the +/-5 % regulation tolerance.

#### **2.4.8.1 SCSI 68 pin Models**

Based on the SCSI Parallel Interface classification, it is recommended that the using system comply with 'Case 3' guidelines to eliminate the chance of affecting the active bus.

In systems that cannot afford to quiesce the SCSI bus but can meet the requirements of voltage regulation, operational and non-operational shock, the following guidelines are recommended to minimize the chance of interfering with the SCSI bus:

##### **Plug**

1. Common ground should be made between device and power supply ground
2. Plug device onto the bus
3. Power up device (no special sequencing of +5 V and +12 V required).
4. Device is ready to be accessed

##### **Unplug**

1. Power down device (no special sequencing of +5V and +12V required).
2. Unplug device from bus
3. Remove common ground

#### **2.4.8.2 SCSI SCA-2 Models**

Based on the connector classification called out in SFF-8046, the SCA-2 connector drive is designed to be 'Case 4' compliant when the system has properly implemented the SFF-8046 guidelines.

## 2.5 Bring-up Sequence (and Stop) Times

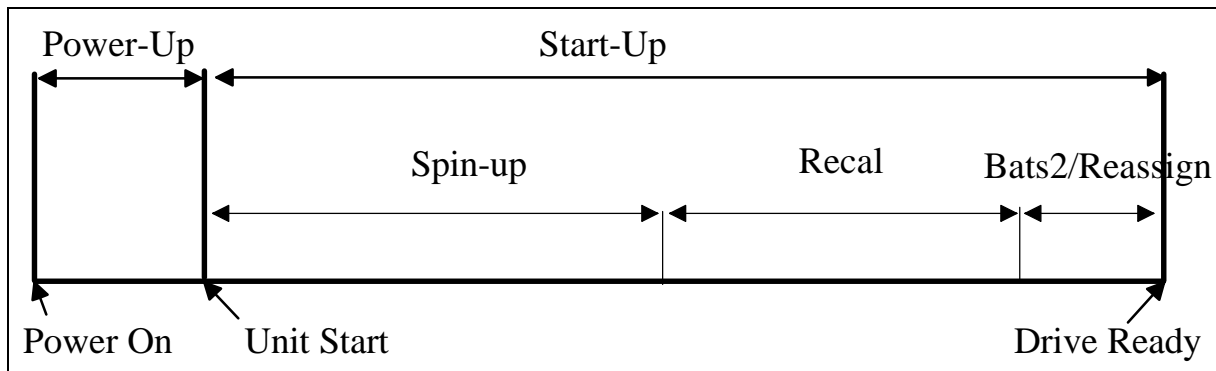

Fig 9. Start Time Diagram

### Definitions:

- Power-Up Time: Time for completion of Power-on-Reset, Code load from flash SRAM for IP and SP, BATS1 testing.
- Spin-Up: Time it takes to go from 0 to 10,020 rpm
- Recal: Time needed for complete recal on all heads.
- BATS2/Reassign: Time it takes to do the R/W tests and complete any necessary reassigns.

A full Bring-up sequence consists of a Power-up sequence and Start-up sequence as shown above.

“Power On” is defined as when the power at the drive meets all of the power specifications as defined in this document. The Start-up sequence spins up the spindle motor, initializes the servo subsystem, performs the Basic Assurance Tests 2 (BATS2) verifying the read/write hardware, resumes “Reassign in Progress” operations and more. See the *ULTRASTAR 18ZX/9LZX Parallel SCSI Disk Drive Logical Interface Specification* for additional details on the Start-up sequence. If a SCSI Reset is issued while the drive is in either a Power-Up or Start-up sequence, that same sequence starts again. In all other cases when a SCSI Reset is issued the present state of the motor is not altered. Reference section 3.11.3, “Start/Stop Unit Time” on page 40 for additional details.

A start-up sequence initiated by SCSI “Start/Stop Unit” command that follows a spindle stop initiated by a SCSI “Start/Stop Unit” command by less than 10 seconds may result in the start-up sequence increasing by as much as 10 seconds. For example, if a delay of only 3 seconds exists between the two command the second command takes 7 seconds longer than if 10 seconds or more had been allowed between the commands.

	UltraStar 9LZX		UltraStar 18ZX	
	Nominal (sec)	Worst Case <sup>7</sup> (sec)	Nominal (sec)	Worst Case (sec)
Power-Up	2.5	3	2.5	3
Start attempts	0	4.6	0	4.6
Spin-Up	9	11.3	10.7	13
Servo Recal	6.1	7.2	9.7	10.8
Bats2/Reassign	0.5	1	0.5	1
<b>Start-Up Time</b>	<b>15.6</b>	<b>23.8</b>	<b>20.9</b>	<b>29.4</b>

Table 8. Bring-up Sequence Times

### 2.5.1 Spin Down Times

After power is removed the drive should be allowed 20 seconds to park the heads and spin down before any attempt is made to handle the drive.

<sup>7</sup> Worst Case represents a 3-sigma event.



---

## 3 Performance

Drive performance characteristics listed in this chapter are typical values provided for information only, so that the performance for environments and workloads other than those shown as examples can be approximated. Actual minimum and maximum values will vary depending upon factors such as workload, logical and physical operating environments and manufacturing process variations.

---

### 3.1 Environment Definition

Drive performance criteria is based on the following operating environments. Deviations from these environments may cause deviations from values listed in this specification.

- Nominal physical environment (voltage, temperature, vibration, etc.) as defined elsewhere in this specification.
- Block lengths are formatted at 512 bytes per block.
- The number of data buffer segments is 16. The total data buffer length is 3679 KB. The size of each equally sized segment, in either bytes or blocks, is determined via the SCSI Mode Page 8h parameter called "Cache Segment Size".
- Ten byte SCSI Read and Write commands are used.
- SCSI environment consists of a single initiator and single target with no SCSI Bus contention.
- Buffer full/empty ratios are set to their optimum values such that a minimum number of intermediate disconnects occur during the SCSI data transfer and the overlap of the SCSI and disk data transfer is maximized. This minimizes Command Execution Times with no bus contention.
- Read Caching and Read Ahead functions are enabled and Write Caching is disabled, except where noted.
- The initiator delay while transferring SCSI command, status, message, and data bytes is assumed to be zero.
- Tagged Command Queuing is not used, unless otherwise specified.
- All Current Mode Parameters are set to their Default values except where noted.
- SCSI data transfers are successfully negotiated to be 80 MB/s.
- Averages are based on a sample size of 10,000 operations.

---

### 3.2 Workload Definition

The drive's performance criteria is based on the following command workloads. Deviations from these workloads may cause deviations from this specification.

- Operations are either all Reads or all Writes.
- The time between the end of an operation, and when the next operation is issued is 50 ms, +/- a random value of 0 to 50 ms, unless otherwise noted.

#### 3.2.1 Sequential

- No Seeks. The target LBA for all operations is the previous LBA + Transfer Length.

#### 3.2.2 Random

- All operations are to random LBAs. The average seek is an average weighted seek.

### 3.3 Command Execution Time

Command Execution or Service Times are the sum of several basic components. Those components are:

1. Seek
2. Latency
3. Command Execution Overhead
4. Data Transfer to/from Disk
5. Data Transfer to/from SCSI Bus

The impact or contribution of those basic components to Command Execution Time is a function of the workload being sent to the drive and the environment in which the drive is being operated.

The following graphs show Command Execution Times for four generic workloads:

- Sequential Reads
- Sequential Writes
- Random Reads
- Random Writes

with several different requested transfer lengths while running in various environments whose key factors are identified under each graph.

**Note:** Times are calculated with typical data sector transfer rates for LVD mode and are averaged over the entire drive.

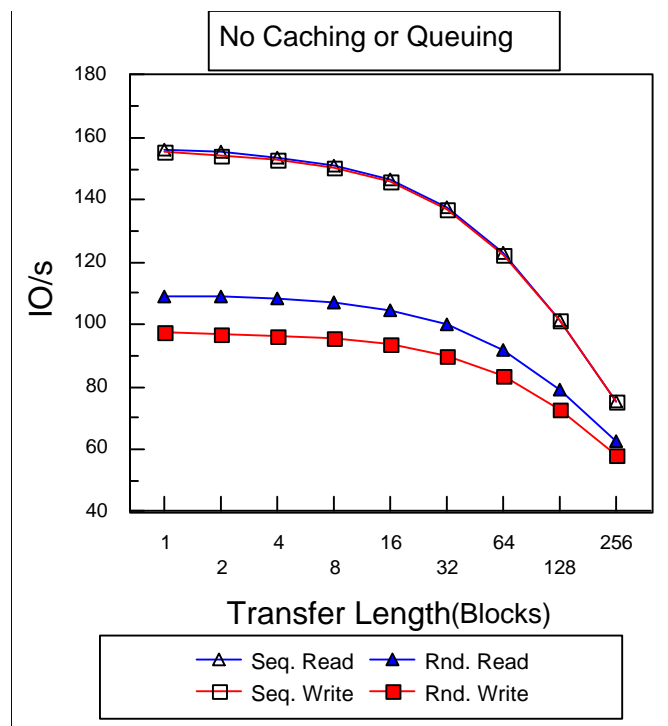

Fig 10. Ultrastar 9LZX with no caching or queuing

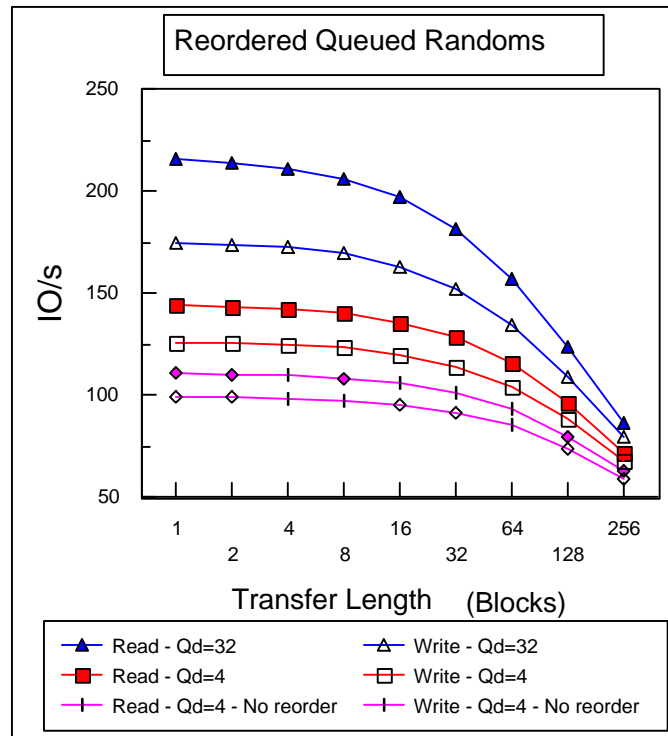

Fig 11. Ultrastar 9LZX random reads and writes with and without reordering

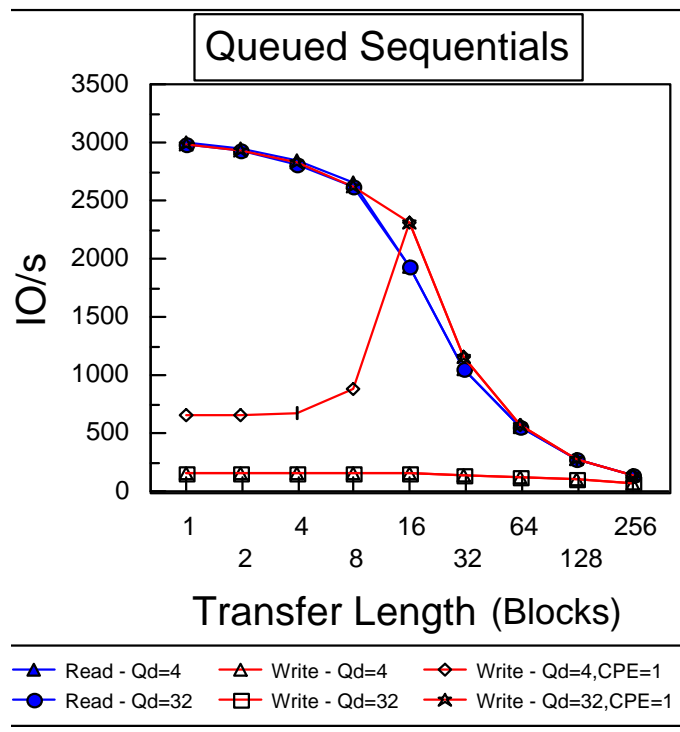

Fig 12. Ultrastar 9LZX queued sequential performance

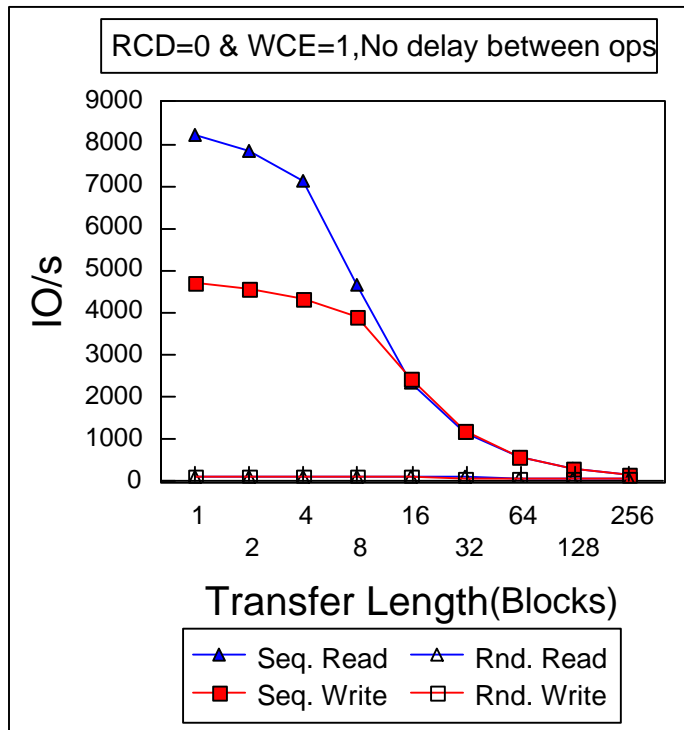

Fig 13. Ultrastar 9LZX with Write Cache on and Read Cache on

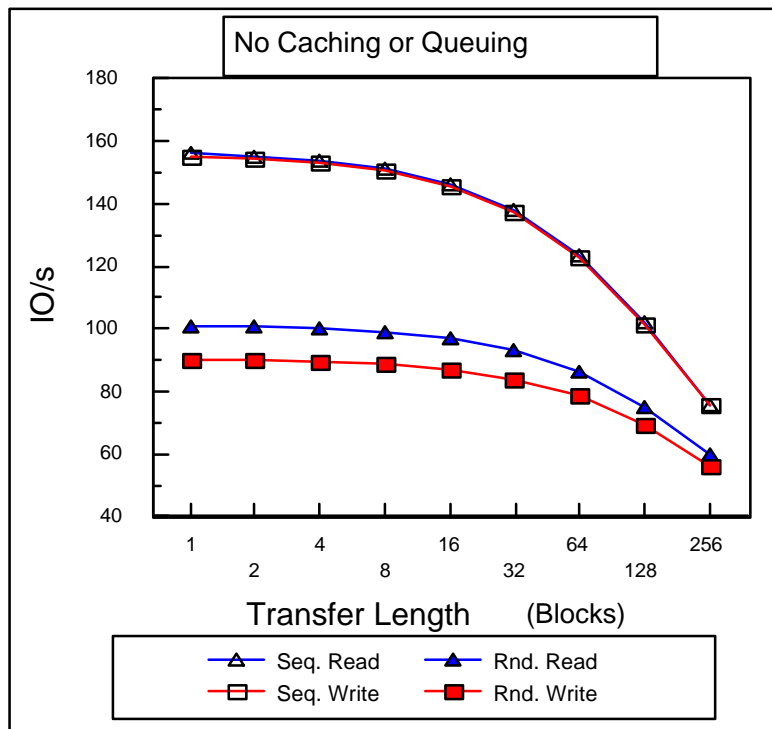

Fig 14. Ultrastar 18ZX with no caching or queuing

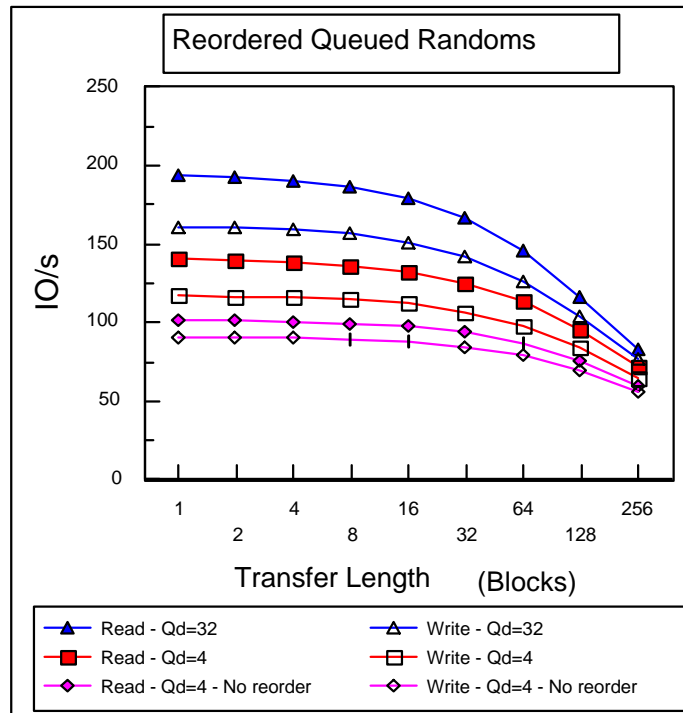

Fig 15. Ultrastar 18ZX random reads and writes with and without reordering

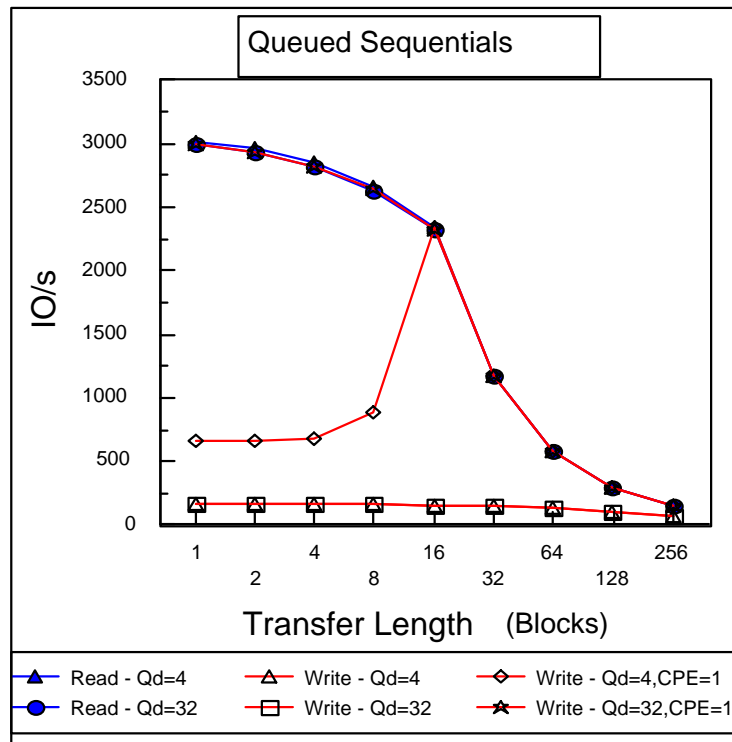

Fig 16. Ultrastar 18ZX queued sequential performance

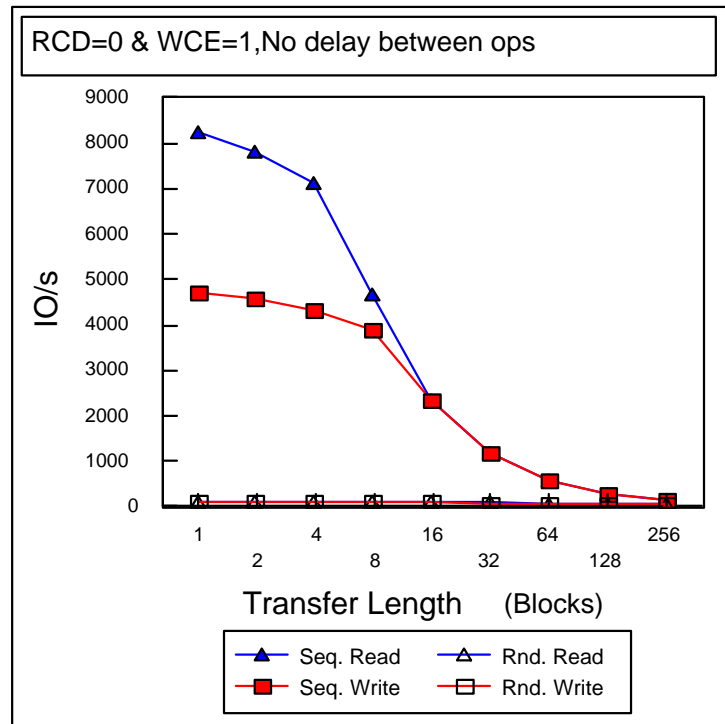

Fig 17. Ultrastar 18ZX with Write Cache on and Read Cache on

### 3.3.1 Basic Component Descriptions

#### 3.3.1.1 Seek

The average time from the initiation of the seek to the acknowledgment that the R/W head is on the track that contains the first requested LBA. The values used for sequential command calculations should be 0 ms and the values for random commands are shown in section 2.1, "General".

#### 3.3.1.2 Latency

The average time required from the activation of the read/write hardware until the target sector has rotated to the head and the read/write begins. This time is 1/2 of a revolution of the disk, or 3 ms.

#### 3.3.1.3 Command Execution Overhead

The average time added to the Command Execution Time due to the processing of the SCSI command. It includes all time the drive spends processing a command while not doing a disk operation or SCSI data transfer, whether or not it is connected to the bus. (See section 3.6, "Read Command Performance" and section 3.7, "Write Command Performance" for examples of detailed descriptions of the components of Command Execution Overhead.) The value of this parameter varies greatly depending upon workloads and environments.

The following values are used when calculating the Command Execution Times.

<b>Workload</b>	<b>Command Execution</b>	<b>SCSI Bus</b>
Sequential Read	0.65	0.03
Sequential Read with Read Ahead	0.09	0.03
Sequential Write	0.74	0.04
Sequential Write with Write Cache	0.19	0.04
Random Read	0.22	0.03
Random Read with Read Ahead	0.32	0.03
Random Write	0.35	0.03

Table 9. Overhead Values (milliseconds)

Other Initiator controlled factors such as use of disconnects, Tagged Command Queuing and the setting of Mode Parameters like DIMM, DPSDP and ASDPE also affect Command Execution Overhead. They also affect SCSI Bus Overhead which is partially a subset of Command Execution Overhead.

**SCSI Bus Overhead** is defined as the time the device is connected to the bus transferring all SCSI Command, Status and Message phase information bytes. This includes any processing delays between SCSI Bus phases while remaining connected to the SCSI Bus. Initiator delays while transferring information bytes are assumed to be zero. This time does not include the SCSI Data phase transfer. (See section 3.6, "Read Command Performance" and section 3.7, "Write Command Performance" for more detailed descriptions of the components of SCSI Bus Overhead.)

**Post Command Processing** time of 0.1ms is defined as the average time required for process cleanup after the command has completed. This time indicates the minimum re-instruct time which the device supports. If a re-instruct period faster than this time is used, the difference is added to the Command Execution Overhead of the next operation.

### 3.3.1.4 Data Transfer to/from Disk

The average time used to transfer the data between the media and the drive's internal data buffer. This is calculated from:

$$(\text{Data Transferred})/(\text{Media Transfer Rate}).$$

There are four interpretations of Media Transfer Rate. How it is to be used helps decide which interpretation is appropriate to use.

#### 1. Instantaneous Data Transfer Rate

The same for a given notch formatted at any of the supported logical block lengths. It varies by notch only and does not include any overhead. It is calculated from :

$$1/(\text{individual byte time})$$

#### 2. Track Data Sector Transfer Rate

Varies depending upon the formatted logical block length and varies from notch to notch. It includes the overhead associated with each individual sector. This is calculated from:

$(\text{user bytes/sector})/(\text{individual sector time})$

(Contact an IBM Customer Representative for individual sector times of the various formatted block lengths.)

**Note:** These rates are used to help estimate optimum SCSI Buffer Full/Empty Ratios.

### 3. Theoretical Data Sector Transfer Rate

Also includes time required for track and cylinder skew and overhead associated with each track. Use the following to calculate it.

$\text{Data Sector Transfer Rate} = \text{Bytes per cylinder} / (\text{Time for 1 cyl} + \text{track skew} + 1 \text{ cyl skew})$

### 4. Typical Data Sector Transfer Rates

Also includes the effects of defective sectors and skipped revolutions due to error recovery. (See Appendix B. of the *ULTRASTAR 18ZX/9LZX Parallel SCSI Disk Drive Logical Interface Specification* for a description of error recovery procedures.)

Rates for drives formatted at 512 bytes/block are shown below:

Model Type	For Both Models		Ultrastar 18ZX		Ultrastar 9LZX	
	Instantaneous	Track	Theoretical	Typical	Theoretical	Typical
Average	29.04	21.96	19.26	19.17	19.11	19.03
1	30.46	23.26	20.41	20.31	20.25	20.15
2	30.15	22.49	19.72	19.62	19.56	19.47
3	29.52	22.06	19.30	19.21	19.16	19.06
4	29.05	21.80	19.11	19.02	18.97	18.88
5	28.74	21.46	18.78	18.69	18.64	18.55
6	28.11	20.86	18.26	18.17	18.12	18.03
7	27.79	20.69	18.10	18.01	17.96	17.87
8	27.48	20.35	17.82	17.74	17.69	17.60
9	26.85	19.92	17.47	17.39	17.34	17.26
10	26.28	19.49	17.05	16.97	16.92	16.84
11	25.86	19.32	16.95	16.87	16.82	16.74
12	25.59	19.07	16.70	16.62	16.58	16.50
13	25.23	18.73	16.43	16.35	16.30	16.23
14	24.91	18.55	16.26	16.19	16.14	16.06
15	23.66	17.44	15.31	15.24	15.19	15.12
16	23.40	17.44	15.31	15.24	15.19	15.12

Table 10. Data Sector Transfer Rates (MB/s)

Notes:

1. The values for typical data sector transfer rate assume a typically worst case value of 3 errors in  $10^9$  bits read at nominal conditions for the soft error rate.
2. Contact an IBM customer representative for values when formatted at other block lengths.
3. Each group of cylinders with a different number of gross sectors per track is called a notch. "Average" values used in this specification are sums of the individual notch values weighted by the number of LBAs in the associated notches.

### 3.3.1.5 Data Transfer to/from SCSI Bus

The time required to transfer data between the SCSI bus and the drive's internal data buffer, that is not overlapped with the time for the Seek, Latency or Data Transfer to/from Disk. This time is based on a SCSI synchronous data transfer rate of 40.0 MB/sec.

The SCSI data transfer rate is dependent on the mode, either synchronous or asynchronous. It also depends upon the width of the data path used. Both 8 and 16 bit transfers are supported.

For Low Voltage Differential drives, synchronous data transfer rates of 80 MB/s can be realized for the 16 bit wide transfers, 20 MB/s for the 8 bit wide transfers. When the drive operates in single ended mode synchronous data transfers rates of 40 MB/sec can be realized for the 16 bit wide transfers, 20 MB/sec for the 8 bit wide transfers.

The asynchronous data transfer rate is dependant on both the initiator and target delays to the assertion and negation of the SCSI REQ and ACK signals. It is also dependent on the SCSI cable delays. The drive is capable of supporting 5 MegaTransfer/second (MT/s).

The SCSI data transfer rate specification only applies to the Data phase for logical block data for Read, Write, Write and Verify, etc... commands. The data rate for parameter/sense data for Request Sense, Mode Select, etc. commands is not specified.

### 3.3.2 Comments

Overlap has been removed from the Command Execution Time calculations. The components of the Command Execution Times are truly additive times to the entire operation. For example,

- The SCSI Bus Overhead data is not included in the calculation since some of its components are also components of Command Execution Overhead and the remaining components overlap the Data Transfer to/from Disk. (See section 3.6, "Read Command Performance" and section 3.7, "Write Command Performance" for details.)
- The Post Command Processing times are not components of the Command Execution time therefore they are not included in the calculation of environments where the re-instruct period exceeds the Post Command Processing time.

With Read Ahead enabled, this specification measures a Read or Write command when the immediately preceding command is a Read command (which starts up the Read Ahead function). If the preceding command is a Write command, then the time difference due to Read Ahead is zero.

Longer inter-op delay, or low re-instruction rate, environments are such that the Read Ahead function has filled the drive's internal data cache segment before the next Read or Write command is received.

Environments with inter-op delays less than 1 revolution period, or high re-instruction rates, are such that the Read Ahead function is still in the process of filling the drive's internal data cache segment when the next Read or Write command is received. For sequential reads, Command Execution Time is 1 revolution less than similar operations with equal inter-op delays and Read Ahead disabled.

---

### 3.4 Disconnection During Read/Write Data Phase

If a non zero Maximum Burst Size parameter is specified, the drive disconnects after transferring the number of blocks specified by the Maximum Burst Size parameter. This disconnection requires approximately 33  $\mu$ sec and the subsequent reconnection requires approximately 15  $\mu$ sec.

The drive also disconnects prior to completion of the Data phase if the drive's internal data buffer cache segment becomes empty during a Read command or full during a Write command. This disconnection occurs regardless of the Maximum Burst Size parameter. This disconnection requires approximately 6  $\mu$ sec and the subsequent reconnection requires approximately 15  $\mu$ sec.

## 3.5 Approximating Performance for Different Environments

The values for several basic components may change based on the type of environment and workload. For example, command overhead may change because certain internal control functions may no longer be overlapped with either the SCSI or disk transfers, etc.. The following paragraphs describe which parameters are affected by which features.

### 3.5.1 When Read Caching is Enabled

For read commands with Read Caching Enabled Command Execution time can be approximated by deleting Seek, Latency and Data Transfer to/from Disk times from the normal drive performance timings if all of the requested data is available in a cache segment (cache hit). When some, but not all, of the requested data is available in a cache segment (partial cache hit) Data Transfer to/from Disk will be reduced but not eliminated. Seek and Latency may or may not be reduced depending upon the location of requested data not in the cache and location of the read/write heads at the time the command was received. The contribution of the Data Transfer to/from SCSI Bus to the Command Execution time may increase since a larger, or entire, portion of the transfer may no longer be overlapped with the components that were reduced.

### 3.5.2 When Read Ahead is Enabled

When read ahead is enabled the reduction in command execution times for sequential read workloads (contiguous and noncontiguous) with long inter-op delays can be approximated by using the following equation:

$$-(\text{Latency} + (\text{Xfer Size})/(\text{Disk data rate}) - (\text{Xfer size})/(\text{SCSI data rate})) = \text{Read ahead savings}$$

The magnitude of the performance advantage of Read Ahead with op delays of 0 to 1 rev varies with the size of the delay. Since the range of delays is less than the time for one revolution, the operation is “synchronized to the disk”. The Read Ahead savings can be roughly approximated by :

$$\text{DELAY} - (\text{time for one revolution}) = \text{Read Ahead savings}$$

**Note:** The time also varies with the size of the data transfer due to the difference between the SCSI data transfer rate and disk data rate. This time is insignificant for a 0.5KByte transfer size and has been ignored in the above equation.

### 3.5.3 When Write Caching is Enabled

For write commands with the Write Caching Enabled (WCE) Mode parameter bit set, Command Execution time can be approximated by deleting Seek, Latency and Data Transfer to/from Disk times from the normal drive performance times. The contribution of the Data Transfer to/from SCSI Bus to the Command Execution time may increase since a larger, or entire, portion of the transfer may no longer be overlapped with the components that were reduced.

The reduced times effectively are added to the Post Command Processing Time.

Like Tagged Command Queuing, the potential to reduce Command Execution Overhead exists due to concurrent command processing.

Like Tagged Command Queuing, when the WCE bit is set Back-To-Back write commands are supported. See section 3.5.7, “Back-To-Back Write Commands” for more information.

### 3.5.4 When Adaptive Caching is Enabled

The Adaptive Caching feature attempts to increase Read Cache hit ratios by monitoring workload and adjusting cache control parameters, normally determined by the using system via the SCSI Mode Parameters, with algorithms using the collected workload information.

### 3.5.5 For Queued Commands

The effects of Command Execution Overhead can be reduced significantly if Tagged Command Queuing is enabled since more than 1 command can be operated on concurrently. For instance, while a disk operation is being performed for one command another command can be received via the SCSI bus and placed in the device command queue. Certain environments may cause Command Execution Overhead to increase if the added function to process the queue and the messages associated with queuing is not permitted to overlap with a disk operation.

### 3.5.6 Reordered Commands

If the Queue Algorithm Modifier Mode Parameter field is set to allow it, commands in the device command queue may be executed in a different order than they were received. Commands are reordered so that the Seek and Latency portions of Command Execution time are minimized. The amount of reduction is a function of the location of the 1st requested block per command and the rate at which the commands are sent to the drive.

### 3.5.7 Back-To-Back Write Commands

If all of the requirements are met as stated in the *ULTRASTAR 18ZX/9LZX Parallel SCSI Disk Drive Logical Interface Specification* section describing Back-To-Back write commands, contiguous data from 2 or more consecutive write commands can be written to the disk without requiring any disk Latency.

**Note:** There is a minimum write command transfer length for a given environment where continuous writing to the disk cannot be maintained without missing a motor revolution. When Write Caching is enabled the likelihood is increased that shorter transfer write commands can fulfill the requirements needed to maintain continuous writing to the disk.

---

## 3.6 Read Command Performance

**Note:** This case is for Random SCSI Read commands, with Read Ahead disabled.

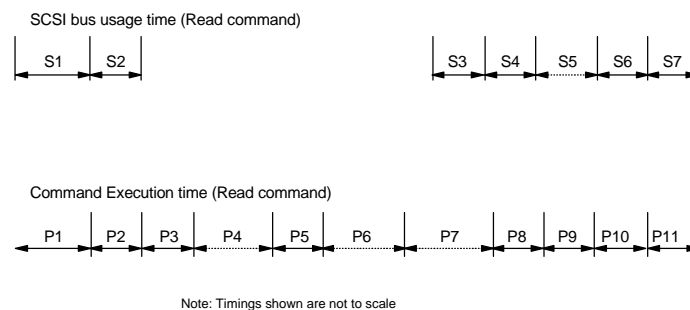

Fig 18. SCSI Read command performance measurements

### 3.6.1 SCSI Bus Overhead

**Note:** All times listed in this section are provided for information only so that the performance for other environments/workloads can be approximated. These component times should not be measured against the specification.

S1	Selection, Identify Msg., Command Descriptor Block (CDB)	15 $\mu$ sec
S2a	Save Data Pointers (SDP) Msg.	1 $\mu$ sec
S2b	Disconnect Msg., Bus Free	1 $\mu$ sec
S3	Arbitrate, Reselect, Identify Msg.	6 $\mu$ sec
S4	Start SCSI transfer in	4 $\mu$ sec
S5	SCSI bus data transfer in	(Transfer size)/(SCSI Data Transfer Rate)
S6	SCSI read ending processing	2 $\mu$ sec
S7	Status, Command Complete Msg., Bus Free	3 $\mu$ sec

**Note:** The SCSI bus overhead for a Read Command is composed of S1,S2(a&b),S3,S4,S6,and S7. (0.03 msec total).

### 3.6.2 Command Execution Overhead

P1	Selection, Identify Msg., CDB	15 $\mu$ sec
P2a	SDP Msg.	1 $\mu$ sec
P2b	Disconnect Msg., Bus Free	1 $\mu$ sec
P3	Start seek or head switch	258 $\mu$ sec
P4	Seek or head switch (for example, average seek)	(Read Seek = 5.8 or 6.5 msec)
P5	Set up read disk transfer	0 $\mu$ sec
P6	Latency (for example, half revolution)	(latency = 3 msec)
P7	Disk data transfer	(Data transferred)/(Typical Data Sector Transfer Rate)
P8	End read disk transfer	(Sector size)/(SCSI Data Transfer Rate)
P9	Transfer last few SCSI blocks in	(5)(Sector size)/(SCSI Data Transfer Rate)
P10	SCSI read ending processing	2 $\mu$ sec
P11	Status, Command Complete Msg., Bus Free	3 $\mu$ sec

**Note:** The Command execution overhead for a read command is composed of P1,P2(a&b),P3,P5,P10,and P11. (0.28 msec total).

$$\text{Time to Read data} = P1+P2+P3+P4+P5+P6+P7+P8+P9+P10+P11$$

## 3.7 Write Command Performance

**Note:** This case is for Random SCSI Write commands, with Read Ahead disabled.

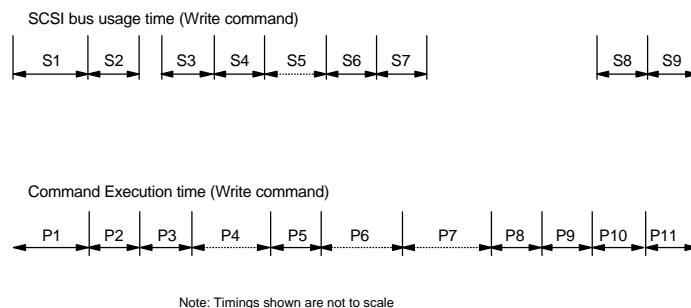

Fig 19. SCSI Write Command Performance Measurements

### 3.7.1 SCSI Bus Overhead

**Note:** All times listed in this section are provided for information only so that the performance for other environments can be approximated. These component times should not be measured against the specification.

S1	Selection, Identify Msg., CDB	15 $\mu$ sec
S2a	SDP Msg.	1 $\mu$ sec
S2b	Disconnect Msg., Bus Free	1 $\mu$ sec
S3	Arbitrate, Reselect, Identify Msg.	6 $\mu$ sec
S4	start SCSI transfer out	4 $\mu$ sec
S5	SCSI bus data transfer out	(Transfer size)/(SCSI Data Transfer Rate)
S6	End SCSI transfer out	4 $\mu$ sec
S7A	SDP Msg.	1 $\mu$ sec
S7B	Disconnect Msg., Bus Free	1 $\mu$ sec
S8	Arbitrate, Reselect, Identify Msg.	6 $\mu$ sec
S9	Status, Command Complete Msg., Bus Free	3 $\mu$ sec

**Note:** The SCSI bus overhead for a write command is composed of S1,S2(a&b),S3,S4,S6,S7,S8 and S9. (0.4 msec total).

### 3.7.2 Command Execution Overhead

P1	Selection, Identify Msg., CDB	15 $\mu$ sec
P2a	SDP Msg.	1 $\mu$ sec
P2b	Disconnect Msg., Bus Free	1 $\mu$ sec
P3	Start seek	258 $\mu$ sec
P4	Seek (for example, average seek)	(Write Seek = 6.8 or 7.5 msec)
P5	Set up write disk transfer	0 $\mu$ sec
P6	Latency (for example, half revolution)	(Latency = 3 msec)
P7	Disk data transfer	(Data transferred)/(Typical Data Sector Transfer Rate)
P8	End write disk transfer	75 $\mu$ sec
P9	SCSI write ending processing	25 $\mu$ sec
P10	Arbitrate, Reselect, Identify Msg.	6 $\mu$ sec
P11	Status, Command Complete Msg., Bus Free	3 $\mu$ sec

**Note:** The Command execution overhead for a write command is composed of P1, P2(a&b), P3, P5, P8, P9, P10 and P11. (0.38 msec total).

$$\text{Time to Write data} = P1+P2+P3+P4+P5+P6+P7+P8+P9+P10+P11$$

---

## 3.8 Skew

### 3.8.1 Cylinder to Cylinder Skew

Cylinder skew is the sum of the sectors required for physically moving the heads, which is a function of the formatted block length and recording density (notch #). Cylinder skew is always a fixed time and therefore the number of sectors varies depending on which notch is being accessed and the block length. The minimum amount of time required for a cylinder switch is 2 ms.

### 3.8.2 Track to Track Skew

Track skew is the time required to perform a switch between heads on the same cylinder. That time is 0.83 ms.

---

## 3.9 Idle Time Functions

The execution of various functions by the drive during idle times may result in delays of commands requested by SCSI initiators. 'Idle time' is defined as time spent by the drive not executing a command requested by a SCSI initiator. The functions performed during idle time are:

1. Predictive Failure Analysis (PFA)
2. Save Logs and Pointers
3. Disk Sweep

The command execution time for SCSI commands received while performing idle time activities may be increased by the amount of time it takes to complete the idle time activity. Arbitration, Selection, Message and Command phases, and disconnects controlled by the drive are not affected by idle time activities.

**Note:** Command Timeout Limits do not change due to idle time functions.

Following are descriptions of the various types of idle functions, how often they execute and their duration. Duration is defined to be the maximum amount of time the activity can add to a command when no errors occur. No more than one idle function will be interleaved with each SCSI command. Following the descriptions is a summary of the possible impacts to performance.

There are mechanisms to lessen performance impacts and in some cases virtually eliminated those impacts from an Initiator's point of view.

1. Normal recommended operation

Idle time functions are only started if the drive has not received a SCSI command for at least 5 seconds. This means that multiple SCSI commands are accepted and executed without delay if the commands are received by the drive within 5 seconds after the completion of a previous SCSI command.

2. No PFA operation

Idle time initiated PFA can be disabled by setting the PERF bit in Mode Page 1Ch. See the *ULTRASTAR 18ZX/9LZX Parallel SCSI Disk Drive Logical Interface Specification* for details.

### 3.9.1 Predictive Failure Analysis

PFA monitors drive parameters and can predict if a drive failure is imminent. There are "symptom driven" PFA processes which occur during error recovery procedures. The impacts of these upon perceived performance are not included here since they are included in the normal error recovery times, which are taken into account by the "Typical Data Sector Transfer Rate".

There are also "measurement driven" PFA processes which occur during idle time. Seven different PFA measurements are taken for each head. All measurements for all heads are taken over a period of 4 hours, therefore the frequency of PFA is dependent on the number of heads. The drive attempts to spread the measurements evenly in time and each measurement takes about 80 milliseconds.

For example, with 10 heads one PFA measurement will be made every 3.4 minutes ( $240/(7*10)$ ).

For the last head tested for a particular measurement type (once every 1/2 hour), the data is analyzed and stored. The extra execution time for those occurrences is approximately 40 milliseconds.

This measurement/analysis feature can be disabled for critical response time periods of operation by setting the Page 1Ch Mode Parameter PERF = 1. See the *ULTRASTAR 18ZX/9LZX Parallel SCSI Disk Drive Logical Interface Specification* for more details about PFA.

### 3.9.2 Save Logs and Pointers

The drive periodically saves data in logs in the reserved area of the disks. The information is used by the drive to support various SCSI commands and for the purpose of failure analysis.

Logs are saved every 26-35 minutes. The amount of time it takes to update the logs varies depending on the number of errors since the last update. In most cases, updating those logs and the pointers to those logs will occur in less than 30 milliseconds.

### 3.9.3 Disk Sweep

The heads are moved to another area of the disk if the drive has not received a SCSI command for at least 40 seconds. After flying in the same spot for 9 minutes without having received another SCSI command, the heads are moved to another position. If no other SCSI command is received, the heads are moved every 9 minutes thereafter. As soon as a SCSI command is received, the period for the 1st occurrence is reduced back down to 40 seconds. The period is increased back to 9 minutes for subsequent occurrences should no more SCSI commands be received during that time. Execution time is less than 1 full stroke seek.

### 3.9.4 Summary

Idle Time Function Type	Period of Occurrence (minutes)	Duration (ms)	Mechanism to delay	Mechanism to disable
PFA	30/(trk/cyl)	80	Re-instruction period	PERF
Save Log & Pointers	26	30	Re-instruction period	
Disk Sweep	2/3 - since last command	17	Re-instruction period	
	9 - since last occurrence			
<b>Note:</b> "Re-instruction period" is the time between consecutive SCSI command requests				

Table 11. Summary of Idle Time Functions

## 3.10 Temperature Monitoring

The drive is equipped with an internal temperature sensor which is used to log the drive's operating environment and optionally notify the using system if the temperature passes beyond the drives maximum operating range. The sensor is physically mounted on the reverse side of the electronics card but is calibrated to report the DE casting temperature.

The algorithm used is as follows:

- Starting 15 minutes after power on the temperature is sampled. If it is below 50C then no further action is taken and the temperature will continued to be sampled at 15 minute intervals.
- If the temperature is between 50C and 65C an internal flag is set to signal a PFA event and the temperature is internally logged by the drive. See the *ULTRASTAR 18ZX/9LZX Parallel SCSI Disk Drive Logical Interface Specification* for the actions which may be taken when a PFA event is signaled and how they may be controlled by the host system. While the temperature remains in the range 50C to 65C the temperature will be re-sampled every 15 minutes and potentially additional PFA events signaled.

- If the temperature exceeds 65C then action similar to the 50C to 65C range is taken but the sampling interval is shortened to 10 minutes.
- Once either of the thresholds above has been crossed hysteresis is applied to the sensor so that to exit the state the drive temperature must drop 5C below the point that triggered the activity, i.e. drop below 60C and 45C respectively.

Measuring the drive's temperature takes approximately 440 microseconds. The internal logging of this temperature by the drive, i.e. writing the value to a reserved area of the drive, is done as a part of saving of logs and pointers described under idle time functions.

### 3.11 Command Timeout Limits

The 'Command Timeout Limit' is defined as the maximum time allowed from the SCSI Arbitration phase through the SCSI Command Complete message, associated with a particular command.

The following times are for environments where Automatic Reallocation is disabled and there are no queued commands.

#### 3.11.1 Reassignment Time

The drive should be allowed a minimum of 45 sec to complete a "Reassign Blocks" command.

#### 3.11.2 Format Time

An average of 30 minutes should be allowed to complete a "Format Unit" command for the Ultrastar 9LZX and an average of 60 minutes should be allowed to complete a "Format Unit" command for the Ultrastar 18ZX. If the vendor unique mode page 00h bit named "FFMT" is set equal to '1'b then the drive should be allowed 30 seconds to complete.

#### 3.11.3 Start/Stop Unit Time

The drive should be allowed a minimum of 30 sec to complete a "Start/Stop Unit" command (with Immed bit = 0). Initiators should also use this time to allow start-up sequences initiated by auto start ups and "Start/Stop Unit" commands (with Immed bit = 1) to complete and place the drive in a "ready for use" state.

**Note:** A timeout of one minute or more is recommended but NOT required. The larger system timeout limit allows the system to take advantage of the extensive ERP/DRP that the drive may attempt in order to successfully complete the start-up sequence.

#### 3.11.4 Medium Access Command Time

The timeout limit for medium access commands that transfer user data and/or nonuser data should be a minimum of 30 sec. These commands are

- |                   |                   |
|-------------------|-------------------|
| •Log Sense        | •Rezero Unit      |
| •Mode Select (6)  | •Seek (6)         |
| •Mode Sense (6)   | •Seek (10)        |
| •Pre-Fetch        | •Send Diagnostic  |
| •Read (6)         | •Write (6)        |
| •Read (10)        | •Write (10)       |
| •Read Capacity    | •Write and Verify |
| •Read Defect Data | •Write Buffer     |
| •Read Long        | •Write Long       |
| •Release          | •Write Same       |
| •Reserve          | •Verify           |

**Note:** The 30 sec limit assumes the absence of bus contention and user data transfers of 64 blocks or less. This time should be adjusted for anticipated bus contention and if longer user data transfers are requested.

When Automatic Reallocation is enabled add 45 sec to the timeout of the following commands; Read (6), Read (10), Write (6), Write (10), Write and Verify, and Write Same.

### **3.11.5 Timeout Limits for Other Commands**

The drive should be allowed a minimum of 5 sec to complete these commands:

- Inquiry
- Request Sense
- Read Buffer
- Start/Stop Unit (with Immed bit = 1)
- Synchronize Cache
- Test Unit Ready

The command timeout for a command that is not located at the head of the command queue should be increased by the sum of command time outs for all of the commands that are performed before it is.

---

## 4 Mechanical

---

### 4.1 Weight and Dimensions

	US (Ultrastar 9LZX)	SI Metric (Ultrastar 9LZX)	US (Ultrastar 18ZX)	SI Metric (Ultrastar 18ZX)
Weight	1.49 lb	0.67 kgm	2.32 lb	1.05 kgm
Height	1.00 in.	25.70 mm	1.63 in.	41.48 mm
Width	4.00 in.	101.60 mm	4.00 in.	101.60 mm
Depth	5.75 in.	146.75mm	5.75 in.	146.75 mm
<b>Notes:</b> These are nominal weights and dimensions provided for reference only. The dimensional tolerances are shown in the next 4 figures. The weight tolerance is +/- 10%. Card interface types and disk quantity determine the weight variability.				

Table 12. Weight and Dimensions

---

### 4.2 Clearances

A minimum of 2 mm clearance should be given to the bottom surface except for a 10 mm maximum diameter area around the bottom mounting holes.

There should be 7 mm of clearance between the IBM drives that are mounted with their top sides facing each other. Drives from other manufactures may require additional spacing due to stray magnetic fields.

**Note:** For proper cooling it is suggested that a minimum clearance of 7 mm be provided under the drive and on top of the drive. For further information see section 7.1.1, "Temperature Measurement Points".

---

### 4.3 Mounting Guidelines

The drive can be mounted with any surface facing down.

The drive is available with both side and bottom mounting holes. Refer to figure 20, "Location of side mounting holes on Ultrastar 9LZX" and figure 21, "Location of side mounting holes on Ultrastar 18ZX". Also figure 22, "Location of bottom mounting holes (68 pin SCSI version)" and figure 23, "Location of bottom mounting holes (80 pin SCA-2 SCSI version)" for the location of these mounting holes for each configuration.

The maximum allowable penetration of the mounting screws is 4.0 mm. Screws longer than 4.0 mm may cause permanent damage to the drive.

The recommended torque to be applied to the mounting screws is 0.8 Newton-meters +/- 0.2 Newton-meters. IBM will provide technical support to users that wish to investigate higher mounting torques in their application.

For more information on mounting guidelines see section 7.5, "Drive Mounting Guidelines".

### 4.3.1 SCA-2 Mounting Guidelines

Since the SCA-2 mounting system lacks the compliant cabling of alternate connectors the system designer must now consider the following mounting situations and design the system appropriately for long term reliability. This list of guidelines is not intended to be exhaustive.

1. The SCA-2 connector should not be required to support the weight of the drive
2. Operational vibration occurring between the mating halves of the SCA-2 connector should be avoided.
3. The drive should be firmly secured once the connector mate has occurred.
4. The connector was designed to allow for 'mismatch' or offset during plug-in operation. Excessive offsets between the drive connector and backplane will induce stress on the connector system and card.

**WARNING:** The drive may be sensitive to user mounting implementation due to frame distortion effects. IBM will provide technical support to assist users to overcome mounting sensitivity.

## 4.4 Mounting Drawings

### 4.4.1 Side Mounts (All)

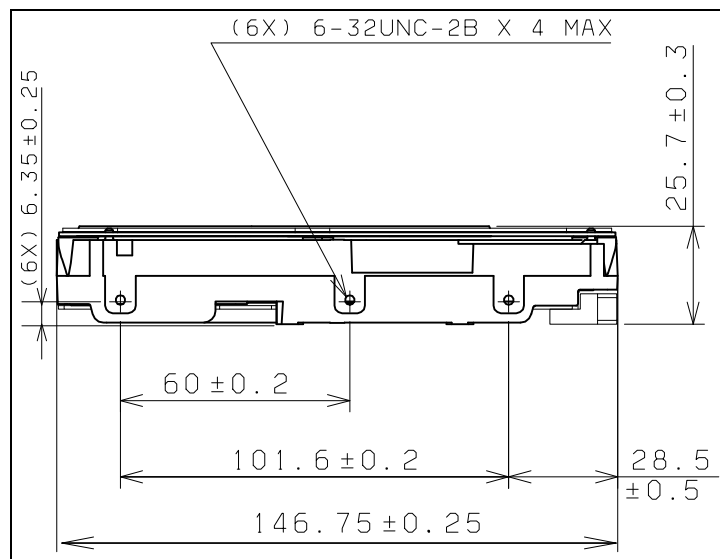

Fig 20. Location of side mounting holes of Ultrastar 9LZX.

**Note:**

1. Dimensions are in millimeters.
2. Clearance = 7 mm

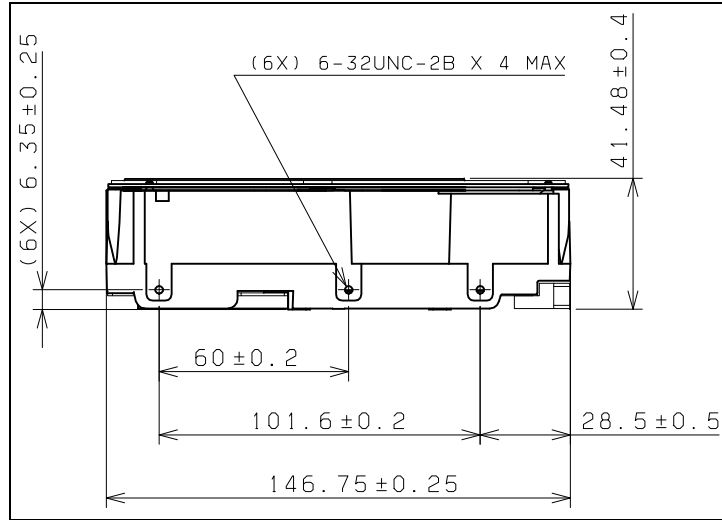

Fig 21. Location of side mounting holes of Ultrastar 18ZX

**Note:**

1. Dimensions are in millimeters.
2. Clearance = 7 mm

**4.4.2 68 Pin SCSI Bottom Mounts**

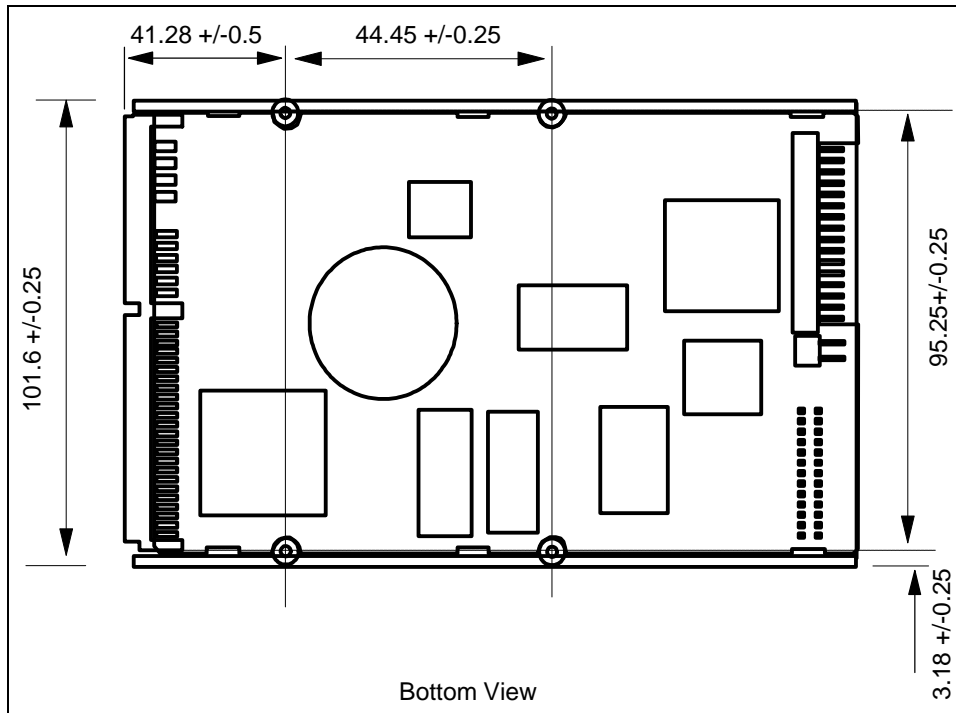

Fig 22. Location of bottom mounting holes (68 pin SCSI version)

### 4.4.3 80 Pin SCA-2 SCSI Bottom Mounts

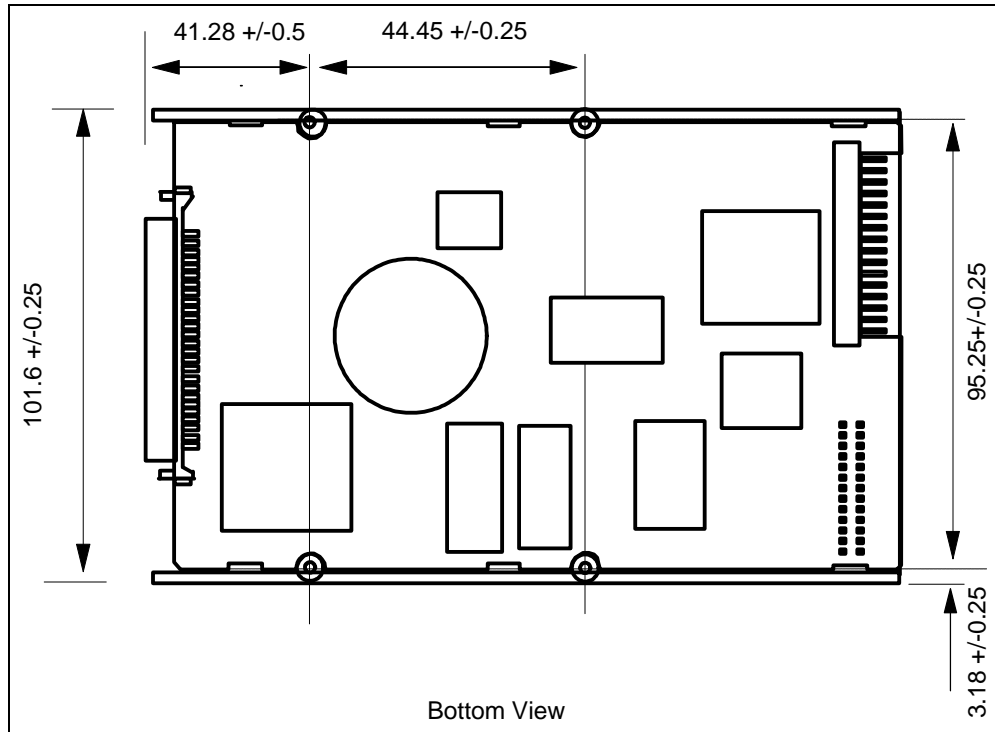

Fig 23. Location of bottom mounting holes (80 pin SCA-2 SCSI version)

## 4.5 Electrical Connectors

### 4.5.1 68 Pin SCSI

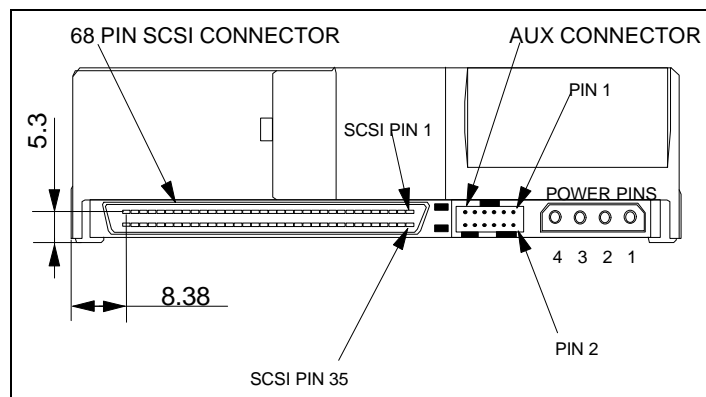

Fig 24. 68 pin SCSI Electrical Connector

### 4.5.2 80 Pin SCSI

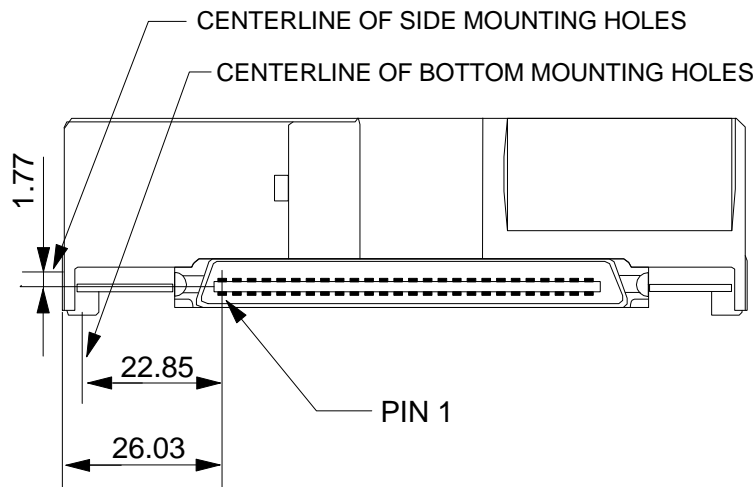

Fig 25. 80 pin SCSI Connector

### 4.5.3 Jumper Pins

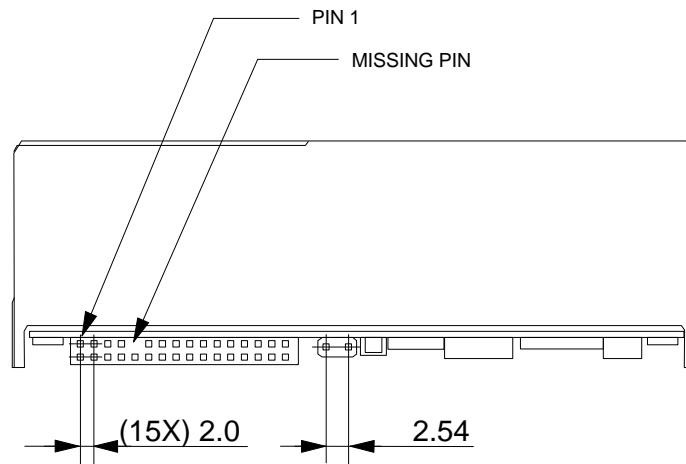

Fig 26. Jumper Pins

---

## 5 Electrical Interface

---

### 5.1 Power Connector

The DC power connectors used on all models (68 and 80 pin SCA-2) are an integral portion of the 68 pin SCSI 'Unitized' Connectors and 80 pin 'Single Connector Attachment' (SCA-2) Connector.

- 68 pin models use a Molex connector (PN 87360-0001) that is compatible with the ANSI SCSI "P" connector.
- The 80 pin SCA-2 models use an AMP connector (PN 5-917593-9) that is compatible with the Specification of: 'Single Connector Attachment for Small SCSI Disk Drives' SFF-8046 draft document, revision 2.7. Placement of the connector is in compliance with the SFF-8337, revision 1.2.
- The connector pins have a plating of 30 micro-inches of gold.

Pin assignments for the 68 pin power connector are shown below.

Pin #	Voltage Level
1	+12 V
2	Ground
3	Ground
4	+5 V

Table 13. Power connector pin assignments

Refer to the section 2.4 entitled "Power Requirements" on page 15 for details on drive power requirements.

---

### 5.2 SCSI Bus Connector

This section describes the varying connectors offered on models of the ULTRASTAR 9LZX/18ZX drives. These connectors have a finish metallurgy 30 micro-inch gold plating.

#### 5.2.1 68 Pin Signal Connector

The 68 pin models use a Molex connector (PN 87360-0001) that is compatible with the ANSI SCSI "P" connector specifications. It can transfer data in both 8 bit (narrow) and 16 bit (wide) modes. Refer to figure 24, "68 pin SCSI Electrical Connector" for a rear view of a 68 pin model.

Signal Name(LVD (SE))	Connector Contact		Signal Name
+DB(12) (GROUND)	1	35	-DB(12)
+DB(13) (GROUND)	2	36	-DB(13)
+DB(14) (GROUND)	3	37	-DB(14)
+DB(15) (GROUND)	4	38	-DB(15)
+DB(P1) (GROUND)	5	39	-DB(P1)
+DB(0) (GROUND)	6	40	-DB(0)
+DB(1) (GROUND)	7	41	-DB(1)
+DB(2) (GROUND)	8	42	-DB(2)
+DB(3 ) (GROUND)	9	43	-DB(3)
+DB(4) (GROUND)	10	44	-DB(4)
+DB(5) (GROUND)	11	45	-DB(5)
+DB(6) (GROUND)	12	46	-DB(6)
+DB(7) (GROUND)	13	47	-DB(7)
+DB(P) (GROUND)	14	48	-DB(P)
GROUND	15	49	GROUND
GROUND	16	50	GROUND
TERMPWR	17	51	TERMPWR
TERMPWR	18	52	TERMPWR
OPEN	19	53	OPEN
GROUND	20	54	GROUND
+ATN (GROUND)	21	55	-ATN
GROUND	22	56	GROUND
+BSY (GROUND)	23	57	-BSY
+ACK (GROUND)	24	58	-ACK
+RST (GROUND)	25	59	-RST
+MSG (GROUND)	26	60	-MSG
+SEL (GROUND)	27	61	-SEL
+C/D (GROUND)	28	62	-C/D
+REQ (GROUND)	29	63	-REQ
+I/O (GROUND)	30	64	-I/O
+DB(8) (GROUND)	31	65	-DB(8)
+DB(9) (GROUND)	32	66	-DB(9)
+DB(10) (GROUND)	33	67	-DB(10)
+DB(11) (GROUND)	34	68	-DB(11)
<b>Notes:</b> For 8 bit LVD devices in LVD or SE mode the following signals must be tied inactive (+ = inactive low, - = inactive high). +/-DB(8), +/-DB(9), +/-DB(10), +/-DB(11), +/-DB(12), +/-DB(13), +/-DB(14), +/-DB(15), +/-DB(P1) Floating these signals is not sufficient.  All other signals shall be connected as defined.			

Table 14. 68 Pin LVD and SE SCSI Connector Contact Assignments

### **5.2.2 80 Pin (Single Connector Attachment) Connector**

The 80 pin SCA-2 models use an AMP connector (PN 5-917593-9) that is compatible with the Specification of: 'Single Connector Attachment for Small SCSI Disk Drives' SFF-8046 draft document, revision 2.7. Placement of the connector is in compliance with the SFF-8337, revision 1.2.

This connector has a finish metallurgy of 30 micro-inch gold plating.

Data transfers in both 8 bit (narrow) and 16 bit (wide) modes are supported. Refer to 4.5.2, "80 pin SCSI Connector" for a rear view of an 80 pin model.

Signal Name	Connector Contact Number		Signal Name (LVD (SE))
12 V Charge	1	41	12V Charge (12V Ground)
12 Volt	2	42	12 Volt (12V Ground)
12 Volt	3	43	12 Volt (12V Ground)
12 Volt	4	44	Mated 1 (Mated 1)
Reserved /NC	5	45	Reserved/NC (Reserved /NC)
Reserved /NC	6	46	Diffsens (Ground)
-DB(11)	7	47	+DB(11) (Ground)
-DB(10)	8	48	+DB(10) (Ground)
-DB(9)	9	49	+DB(9) (Ground)
-DB(8)	10	50	+DB(8) (Ground)
-I/O	11	51	+I/O (Ground)
-REQ	12	52	+REQ (Ground)
-C/D	13	53	+C/D (Ground)
-SEL	14	54	+SEL (Ground)
-MSG	15	55	+MSG (Ground)
-RST	16	56	+RST (Ground)
-ACK	17	57	+ACK (Ground)
-BSY	18	58	+BSY (Ground)
-ATN	19	59	+ATN (Ground)
-DB(P0)	20	60	+DB(P0) (Ground)
-DB(7)	21	61	+DB(7) (Ground)
-DB(6)	22	62	+DB(6) (Ground)
-DB(5)	23	63	+DB(5) (Ground)
-DB(4)	24	64	+DB(4) (Ground)
-DB(3)	25	65	+DB(3) (Ground)
-DB(2)	26	66	+DB(2) (Ground)
-DB(1)	27	67	+DB(1) (Ground)
-DB(0)	28	68	+DB(0) (Ground)
-DB(P1)	29	69	+DB(P1) (Ground)
-DB(15)	30	70	+DB(15) (Ground)
-DB(14)	31	71	+DB(14) (Ground)
-DB(13)	32	72	+DB(13) (Ground)
-DB(12)	33	73	+DB(12) (Ground)
5 Volt	34	74	Mated 2 (Mated 2)
5 Volt	35	75	5 V Ground (5 V Ground)
5 V Charge	36	76	5 V Ground (5 V Ground)
SLAVE SYNC	37	77	Active LED Out (Active LED Out)
AUTO START	38	78	AUTO START DELAY (AUTO START DELAY)
-SCSI ID(0)	39	79	-SCSI ID(1) (-SCSI ID(1))
-SCSI ID(2)	40	80	-SCSI ID(3) (-SCSI ID(3))
<p>Note :</p> <p>For 8 bit LVD devices in LVD or SE mode, the following signals must be tied inactive (+ = inactive low, - = inactive high). +/-DB(8), +/-DB(9), +/-DB(10), +/-DB(11), +/-DB(12), +/-DB(13), +/-DB(14), +/-DB(15), +/-DB(P1). Floating these signals is not sufficient. All other signals shall be connected as defined.</p>			

Table 15. 80 Pin SCA-2 LVD and SE Connector Contact Assignments

### 5.2.3 SCSI Bus Cable

Low Voltage Differential models permit cable lengths of up to 12 meters (39.37 feet) when operating in LVD mode. Cables must meet the requirements for LVD cables as set forth in the Information Technology SCSI Parallel 2 (SPI-2) standard under "Cable Requirements".

In Single-ended SCSI mode cable lengths of up to 6 meters (19.69 feet) are permitted. It should be noted however that users who plan to use "Fast" data transfers with single-ended models should follow all of the ANSI SCSI guidelines for single-ended "Fast" operations. This may include a cable length of less than 6 meters.

When operating in Fast-20 mode cable lengths of 3 meters (9.84 feet) are supported.

SCA-2 connector models are not designed for direct cable attachment due to the combination of power and SCSI bus signals. "Fast" data transfers with SCA models should follow all of the ANSI SCSI guidelines for single-ended "Fast" operations.

The ANSI SCSI standard states that any stub from main cable must not exceed 0.1 meters for single-ended or LVD cables. ULTRASTAR 9LZX/18ZX has a maximum internal stub length of 0.055 meters on all LVD and 'single-ended' SCSI signals. To remain compliant with the standard the SCSI bus cable must not add more than 0.045 meters additional stub length to any of the LVD and single-ended SCSI signals.

#### 5.2.3.1 MATED 1,2 Pin function

The ANSI SPI-2 specification Annex D defines the drive (SCSI device) and backplane requirements for the SCA pins called MATED 1,2. The Annex also defines optional feature support for this signal pair. This signal pair is used to determine if the SCSI device is fully inserted into the mating connector.

This product supports the MATED 1,2 signaling as follows:

- 1) The MATED 2 pin is attached to signal ground on the SCSI device side.
- 2) The MATED 1 pin is sensed by the SCSI device and will respond as follows:

This product will delay normal power up procedures until after the MATED 1 signal is detected to be at GND potential. In addition, this product will delay capture of the SCSI ID until approx 0.5 sec after Mated 1 is at GND potential and all power supplies are within tolerance.

This product detects an open or opening condition on MATED 1 ( change from GND to OPEN) and responds with an immediate spin down sequence. These attributes are not Mode Selectable. There is no provision for Synchronization of the Cache.

### 5.2.4 SCSI Bus Terminators

The using system is responsible for making sure that all required signals are terminated at both ends of the cable. See section 5.2.6, "Single-Ended SCSI Bus Electrical Characteristics" for input capacitance values. There is no active termination supplied on the ULTRASTAR 9LZX/18ZX drives. Termination must be provided externally.

Some external terminator possibilities for 68 pin models are listed below:

68 Pin Model Terminators
Data Mate DM2750-01-LVD (LVD Only)
Amphenol 497040001 (Multimode)

Table 16. LVD Terminators

## 5.2.5 SCSI Bus Termination Power

Termination power is optionally provided for systems that desire to use it. In order to use the termination power, the user needs to install a jumper between pins 1 and 2 of the TermPower Block. The jumper should only be installed on one device, which should be the last device on the SCSI bus (i.e. the drive that is physically closest to a terminator). 68 pin models can source up to 2.0 Amps of current at 5.0 Volts (+/- 5%) for termination power.

### 5.2.5.1 SCSI Bus Termination Power Short Circuit Protection

The ANSI SCSI specification recommends for devices that optionally supply TERMPWR, to include current limiting protection for accidental short circuits. It also recommends that the maximum current available for TERMPWR should be 2 Amps. UL has a different requirement that they call the 8 Amp rule. This rule states that when a power source leaves an enclosure (like SCSI TERMPWR in the SCSI cable), it must trip 8 Amps of current within 1 minute.

The ULTRASTAR 9LZX/18ZX drive limits current to 2.0 Amps through the use of a resettable fuse mounted on the electronics card.

Systems may also provide short circuit protection for drive supplied TERMPWR by limiting the current of the 5 Volt power it supplies to the drive.

## 5.2.6 Single-ended SCSI Bus Electrical Characteristics

The following DC operating characteristics pertain to the single-ended SCSI bus transceivers. All of these parameters meet the Information Technology SCSI Parallel Interface 2 (SPI-2) requirements.

- $T_a = 0$  to  $70$  °C

Symbol	SCSI I/O Parameters	min	max	Units	Notes
V <sub>ol</sub>	low level output voltage		0.5	V	I <sub>out</sub> = 48 mA
V <sub>oh</sub>	high level output voltage	2.5		V	
V <sub>il</sub>	low level input voltage	1.0	1.3	V	
V <sub>ih</sub>	high level input voltage	1.6	1.9	V	
I <sub>il</sub>	low level input current		20	uA	
I <sub>ih</sub>	high level input current		20	uA	
V <sub>ihys</sub>	input hysteresis	0.3	0.53	V	
C <sub>i</sub>	input capacitance		10.2	pF	

Table 17. Single-Ended Bus Electrical Characteristics

## 5.2.7 Low Voltage Differential SCSI Bus Electrical Characteristics

The following DC operating characteristics pertain to the Low Voltage Differential SCSI bus transceivers.

### 5.2.7.1 Stub Length

Minimum and Maximum trace lengths, between the SCSI connector and the SCSI controller die pad, on the ULTRASTAR 9LZX/18ZX SCSI product card are defined in the table below.

Measurement Parameter	Minimum	Maximum	Spec Limit (Maximum)	Unit
Stub Length	32	58	100	mm

Table 18. LVD SCSI Controller to SCSI Connector Stub Length

### 5.2.7.2 Capacitive Loading

The test system used for capacitance measurements, is calibrated such that total capacitance of the system is zero at the mating connector without a SCSI drive plugged into the test system. The test conditions used for measurement purposes are those defined in the SCSI Parallel Interface-2 (SPI-2) specification. The test data provided is based on a small number of lab samples.

### 5.2.7.3 LVD SCSI Single-Ended (SE) Test Results

Measurement Parameter	Maximum Measured	Spec Limit (Maximum)	Unit
68-Pin Connector (No Active Termination)			
C1 (-sig/gnd)	9.4	25	pf
80-Pin Connector (No Active Termination)			
C1 (-sig/gnd)	10.2	25	pf

Table 19. LVD SCSI Controller Single-Ended Capacitive Load Data

Measurement Parameter	Maximum Measured	Spec Limit (Maximum)	Unit
68-Pin Connector (No Active Termination)			
C1 (-sig/gnd)	9.2	20	pf
C2 (+sig/gnd)	9.1	20	pf
C3 (-sig/+sig)	9.1	20	pf
C1-C2 (Data,Parity,REQ,ACK)	0.6	1.5	pf
C1-C2 (All Other Signals)	0.8	3.0	pf
C1(i)-C1(REQ) (Data,Parity)	1.8	2.0	pf
C2(i)-C2(REQ) (Data,Parity)	1.9	2.0	pf
C1(i)-C1(ACK) (Data,Parity)	1.2	2.0	pf
C2(i)-C2(ACK) (Data,Parity)	1.3	2.0	pf
80-Pin Connector (No Active Termination)			
C1 (-sig/gnd)	9.7	20	pf
C2 (+sig/gnd)	9.7	20	pf
C3 (-sig/+sig)	9.0	20	pf
C1-C2 (Data,Parity,REQ,ACK)	0.5	0.5	pf
C1-C2 (All Other Signals)	0.8	3.0	pf
C1(i)-C1(REQ) (Data,Parity)	1.0	2.0	pf
C2(i)-C2(REQ) (Data,Parity)	1.4	2.0	pf
C1(i)-C1(ACK) (Data,Parity)	1.4	2.0	pf
C2(i)-C2(ACK) (Data,Parity)	1.2	2.0	pf

Table 20. LVD SCSI Controller Differential Capacitive Load Data

### 5.2.7.4 Driver Slew Rates

The Slew Rates ( $t_{Rise}$ ,  $t_{Fall}$ ) for Data and REQ are measured on a synchronous data transfer. The test conditions and load circuits used for measurement purposes are those defined in the SCSI Parallel Interface-2 (SPI-2) specification. The test data provided is based on a small number of lab samples.

#### LVD SCSI Single-Ended (SE) Test Results

Measurement Parameter	Maximum Measured	Spec Limit (Maximum)	Unit
80-Pin Connector (No Active Termination)			
$t_{Rise}$ (Data)	510	520	mV/ns
$t_{Fall}$ (Data)	465	520	mV/ns
$t_{Rise}$ (REQ)	482	520	mV/ns
$t_{Fall}$ (REQ)	482	520	mV/ns

Table 21. LVD SCSI Controller Single-Ended Slew Rate Data

**LVD SCSI Differential Test Results**

Measurement Parameter	Maximum Measured	Spec Limit (Minimum)	Unit
80-Pin Connector (No Active Termination)			
t <sub>Rise</sub> (Data)	4.3	1.0	ns
t <sub>Fall</sub> (Data)	4.3	1.0	ns
t <sub>Rise</sub> (REQ)	3.3	1.0	ns
t <sub>Fall</sub> (REQ)	3.3	1.0	ns

Table 22. LVD SCSI Controller Differential Slew Rate Data

**5.2.7.5 Assertion/Negation Periods**

The Assertion/Negation Periods for the REQ signal are measured on a synchronous data transfer. The test conditions and load circuits used for measurement purposes are those defined in the SCSI Parallel Interface-2 (SPI-2) specification. The test data provided is based on a small number of lab samples.

**LVD SCSI Single-Ended (SE) Test Results**

Measurement Parameter	Minimum Measured	Spec Limit (Minimum)	Unit
80-Pin Connector (No Active Termination)			
Assertion Period (REQ)	27	15	ns
Negation Period (REQ)	15.9	15	ns

Table 23. LVD SCSI Controller Single-Ended Assertion/Negation Data

**LVD SCSI Differential Test Results**

Measurement Parameter	Minimum Measured	Spec Limit (Minimum)	Unit
80-Pin Connector (No Active Termination)			
Assertion Period (REQ)	9.3	8.0	ns
Negation Period (REQ)	13.1	8.0	ns

Table 24. LVD SCSI Controller Differential Assertion/Negation Data

**5.2.7.6 Data Setup/Hold Time**

The Data Setup/Hold Times with respect to the REQ signal are measured on a synchronous data transfer. The test conditions and load circuits used for measurement purposes are those defined in the SCSI Parallel Interface-2 (SPI-2) specification. The test data provided is based on a small number of lab samples.

**LVD SCSI Single-Ended (SE) Test Results**

Measurement Parameter	Minimum Measured	Spec Limit (Minimum)	Unit
80-Pin Connector (No Active Termination)			
Setup Time (Data to REQ)	15.8	11.5	ns
Hold Time (REQ to Data)	23.1	16.5	ns

Table 25. LVD SCSI Controller Single-Ended Setup and Hold Time Data

**LVD SCSI Differential Test Results**

Measurement Parameter	Minimum Measured	Spec Limit (Minimum)	Unit
80-Pin Connector (No Active Termination)			
Setup Time (Data to REQ)	10.8	9.25	ns
Hold Time (REQ to Data)	10.6	9.25	ns

Table 26. LVD SCSI Controller Differential Setup and Hold Time Data

### 5.2.7.7 Receiver Hysteresis

Single-Ended Receiver Hysteresis is a measurement of the voltage levels at which the receiver changes state as defined in the SCSI Parallel Interface-2 (SPI-2) specification. The test data provided is based on a small number of lab samples.

#### LVD SCSI Single-Ended (SE) Test Results

Measurement Parameter	Minimum Measured	Spec Limit (Minimum)	Unit
80-Pin Connector (No Active Termination)			
Hysteresis	530	300	mV

Table 27. LVD SCSI Controller Single-Ended Hysteresis Data

## 5.3 Option Block Connector (Jumper Blocks)

ULTRASTAR 9LZX/18ZX models contain a jumper block that can be used to enable certain features and select the SCSI ID of the drive. This jumper block is referred to as the 'Front' Option Jumper Block due to its location on the drive (opposite the SCSI connector). This jumper block varies in pin definition based on interface type ( 68, SCA-2).

The Option Block connector (2x16) used on 68 and 80 pin models is an AMP connector (PN 84156-5) having a pin spacing of 2mm.

The IBM part number for the 2mm jumpers is 45G9800 and the Termination Power Enable jumper part number is 21H0793.

The 45G9800 PN is:-

- 2mm spacing, w/tab 8.5mm long, connector is 3.5 mm long
- Contact -- 30micro-inch gold plating with nickel underplate
- Supplier -- HIROSE A3-SP(B)(13), or approved equivalent.

The 21H0793 PN is:-

- 2.54mm spacing, w/o tab connector is 5.08 mm long
- Contact -- 30micro-inch gold plating with nickel underplate
- Supplier -- METHODE 9608-202-35, or approved equivalent.

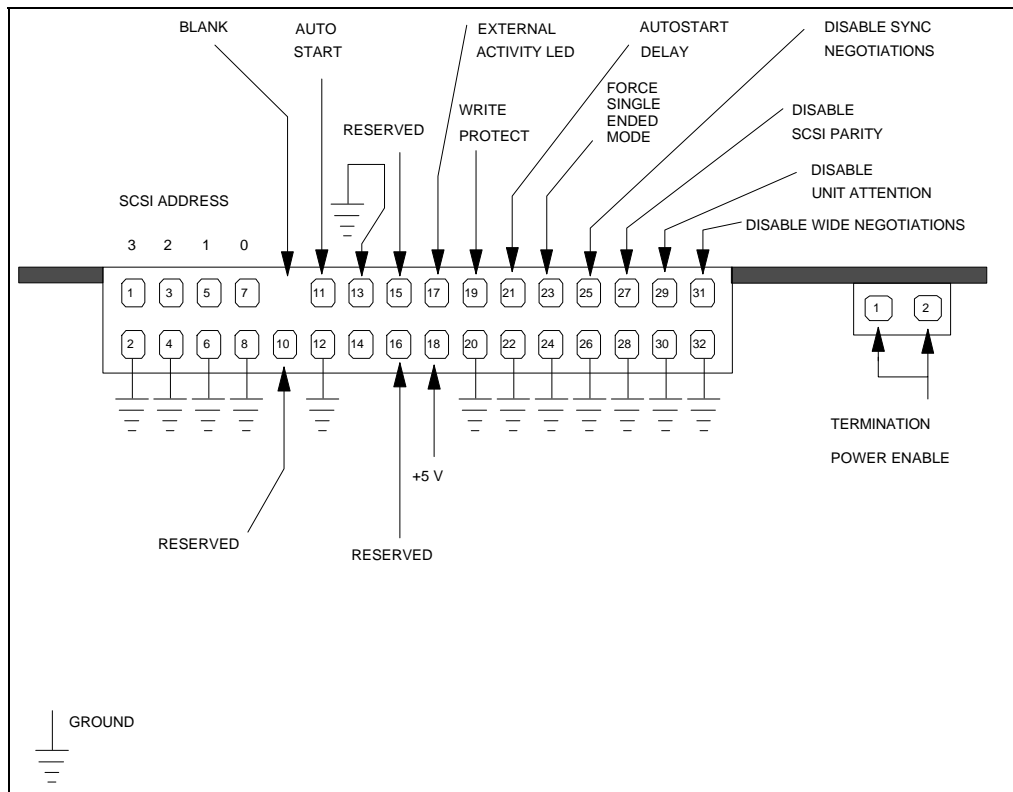

Fig 27. 68 pin Front Option Jumper Block and TermPower Block

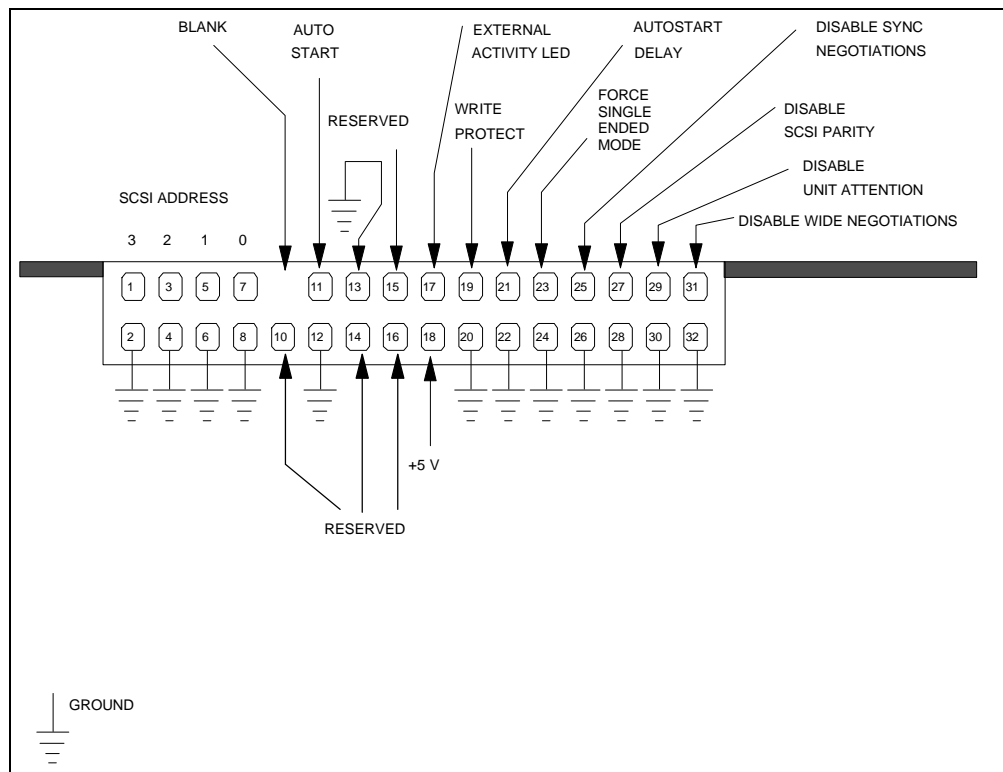

Fig 28. SCA-2 Front Option Jumper Block

### 5.3.1 68 Pin Auxiliary Connector

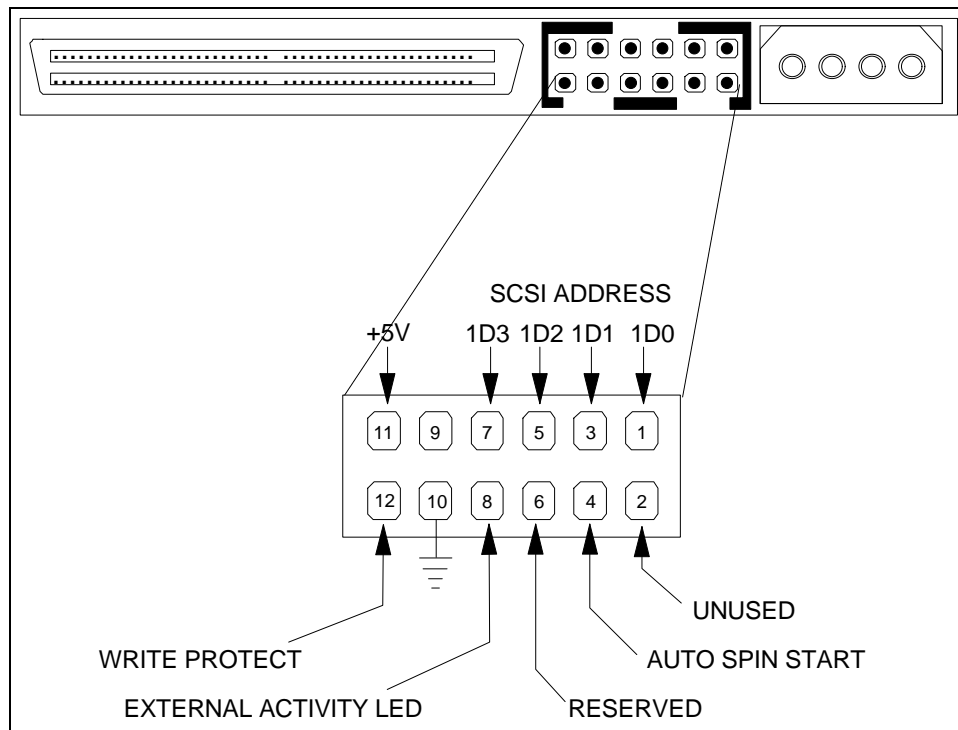

Fig 29. Auxiliary Connector on the 68 pin Connector

**Note :** Either the Front Option Block "OR" the Auxiliary block may be used but not both.

The 68 pin models contain an 'Auxiliary' connector that replicates some of the functions contained in the Front Option Jumper Block. The Auxiliary connector signal definition conforms to the SCSI document: SFF-8009 Rev 2.0 definition with the following exceptions:

1. EXTERNAL FAULT (XTFALT-) is not supported on pin 2
2. AUTO SPIN START was chosen as the 'vendor unique' signal assignment (on pin 4.) (This signal is an input to the drive. The SCSI spec (SCSI SFF-8009) specifies this pin as an output.) This signal should be useful for those applications that want to "auto-start" the drive based on location dependent SCSI ID.

This pin should be handled in one of the following ways:

- tied to ground (auto spin start enabled)
- allowed to 'float' (no connection)
- driven with an open collector driver (>1mA sink capability)

### 5.3.2 SCSI ID (Address) Pins

Information on how to select a particular address for the SCSI device ID is given in the following table.

The SCSI ID can be set via:

- a) the Front Option Block
- b) the SCA connector
- c) the 68 pin 'auxiliary' connector

**Note:** In the address determination table, "off" means either that the jumper is not in place or equivalently that the signal is driven to a CMOS High voltage level. Likewise the term "on" means either that the jumper is in place or that the signal is driven to a CMOS Low voltage level (ie Ground).

BIT 3	BIT 2	BIT 1	BIT 0	ADDRESS
off	off	off	off	0
off	off	off	on	1
off	off	on	off	2
off	off	on	on	3
off	on	off	off	4
off	on	off	on	5
off	on	on	off	6
off	on	on	on	7
on	off	off	off	8
on	off	off	on	9
on	off	on	off	10
on	off	on	on	11
on	on	off	off	12
on	on	off	on	13
on	on	on	off	14
on	on	on	on	15

Table 28. Address Determination of 68 and 80 Pin Models

### 5.3.3 Auto Start (and Delay) Pins

The Auto Start and Auto Start Delay pins control when and how the drive can spin up and come ready. When configured for Auto-Startup, the motor spins up after power is applied without the need of a SCSI Start Unit command. For no Auto-Startup, a SCSI Start Unit command is required to make the drive spin and be ready for media access operations. When in Auto-Startup mode, the drive will delay its start time by a period of time multiplied by its own SCSI address. The following tables shows whether or not Auto-Startup mode is active and the delay periods, where applicable, for all combinations of the pins.

Pins (68 pin model)		Drive Behavior	
AUTO START DELAY	AUTO START	Auto-Startup Mode ?	Delay (sec) Multiplier
off	off	NO	na
off	on	YES	0
on	off	YES	10
on	on	YES	4

Table 29. Auto-Startup Modes selectable by Auto-Start/Delay Pin Combinations (68 pin)

Pins (80 pin model)		Drive Behavior	
AUTO START DELAY	AUTO START	Auto-Startup Mode ?	Delay (sec) Multiplier
off	off	YES	0
off	on	NO	na
on	off	YES	10
on	on	NO	na

Table 30. Auto-Startup Modes selectable by Auto-Start/Delay Pin Combinations (80 pin)

### 5.3.4 External Activity (LED) Pins

The LED pins can be used to drive an external Light Emitting Diode. Please refer to the LED pin section of the *ULTRASTAR 18ZX/9LZX Parallel SCSI Disk Drive Logical Interface Specification* for a detailed functional description of this pin.

Up to 33 mA (+/- 5%) of TTL level LED sink current capability is provided. Current limiting for the LED is as shown in the following diagram.

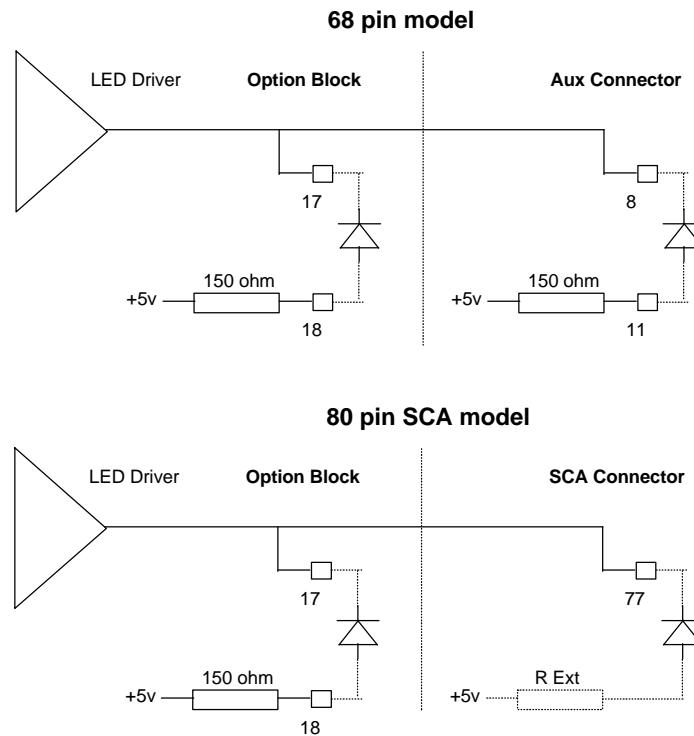

Fig 30. LED Circuit Diagram

### 5.3.5 Write Protect Pin

If the Write Protect pin is jumpered to ground the drive will prohibit SCSI commands that alter the customer data area portion of the media from being performed. The state of this pin is monitored on a per command basis. See the *ULTRASTAR 18ZX/9LZX Parallel SCSI Disk Drive Logical Interface Specification* for functional details.

### **5.3.6 Disable Synchronous Negotiation Pin**

If a Disable Target Initiated Synchronous Negotiation pin is grounded then an Initiator is required to start a negotiation handshake if Synchronous and/or 'Wide' (Double Byte) SCSI transfers are desired. Please refer to the *ULTRASTAR 18ZX/9LZX Parallel SCSI Disk Drive Logical Interface Specification* for more details on this feature.

### **5.3.7 Disable SCSI Parity Pin**

Grounding this pin will disable SCSI Parity checking.

### **5.3.8 Disable Unit Attention Pin**

Grounding this pin will disable the drive from building Unit Attention Sense information for commands immediately following a Power On Reset (POR) or SCSI Bus Reset. Any pending Unit Attention conditions will also be cleared at POR or SCSI Reset times.

### **5.3.9 Disable Wide Negotiations**

Jumpering the pins will cause the drive to operate in single byte mode. The drive will not negotiate 'wide' (double byte) operation.

### **5.3.10 Force Single Ended Mode**

Jumpering pin 23 to pin 24 (refer to the figures in section 5.3) will cause the 68 pin and 80 pin SCA Low Voltage Differential models to operate in a Single Ended mode only. The drive will not use the DIFFSENS line to determine SE or LVD modes.

---

## 6 Reliability

---

### 6.1 Error Detection

Error reporting $\geq$ 99%	All detected errors excluding interface and BATs #1 (Basic Assurance Test) errors.
Error detection $\geq$ 99%	To the device when the 'Recommended Initiator Error Recovery Procedures' in the <i>ULTRASTAR 18ZX/9LZX Parallel SCSI Disk Drive Logical Interface Specification</i> are followed.
FRU isolation = 100%	No isolation to subassemblies within the device are specified.

---

### 6.2 Data Reliability

Probability of not recovering data	10 in $10^{15}$ bits read
Recoverable read errors (Mean of population)	10 in $10^{13}$ bits read (measured at nominal DC conditions and room environment with default error recovery - QPE <sup>8</sup> enabled). With QPE enabled and the default thresholds, error reporting only occurs after step 18.

---

### 6.3 SPQL (Shipped product quality level)

All units are functionally tested immediately prior to packaging and shipment from IBM. When subsequently installed and functionally tested in an approved system, some drives may not pass. In general, the percentage of drives that fail will depend upon adherence to shipping and handling guidelines, functional test criteria and system design compatibility. Contact your technical support representative for further information and assistance.

---

### 6.4 Failure Rate

This product is designed for use in applications where high reliability and availability are critical. In general, actual failure rates will depend on usage conditions and system design compatibility.

Parameters such as ambient temperature, cooling air flow rate, relative humidity, ambient pressure (altitude), applied voltage, shock, vibration, on/off cycles and duty cycle will affect failure rates. Failure rate projections may only be determined from drive system testing. Contact your technical support representative for further information and assistance.

---

### 6.5 Shelf Life

It is recommended that the drive does not remain inoperative for longer than 180 days especially if the shelf environment is at high temperature and humidity.

---

### 6.6 Start Stop Cycles

The maximum number of start stop cycles supported by the Ultrastar 9LZX drives is 20,000. The maximum number of start stop cycles supported by the Ultrastar 18ZX drives is 10,000.

---

<sup>8</sup> Please reference QPE (qualify post error) definition in the *ULTRASTAR 18ZX/9LZX Parallel SCSI Disk Drive Logical Interface Specification*.

---

## 7 Operating Limits

The IBM Corporate specifications and bulletins, such as C-S 1-9700-000 in the contaminants section, that are referenced in this document are available for review.

---

### 7.1 Environmental

- Temperature

Operating Ambient	5 to 50 °C (41 to 122 °F)
Operating Disk Enclosure	5 to 65 °C (41 to 149 °F) Ultrastar 9LZX 5 to 60 °C (41 to 140 °F) Ultrastar 18ZX
Storage	1 to 65 °C (34 to 149 °F) <sup>9</sup>
Shipping	-40 to 65 °C (-40 to 149 °F)

- Temperature Gradient

Operating Shipping and storage	20 °C (36 °F) per hour below condensation
-----------------------------------	--

- Humidity

Operating	5% to 90% non condensing
Storage	5% to 90% non condensing
Shipping	5% to 95% (Applies at the packaged level)

- Wet Bulb Temperature

Operating Shipping and Storage	26.7 °C (80 °F) maximum 29.4 °C (85 °F) maximum
-----------------------------------	--

- Elevation

Operating and Storage Shipping	-304.8 to 3048 meters (-1000 to 10,000 feet) -304.8 to 12,192 meters (-1000 to 40,000 feet)
-----------------------------------	--

#### 7.1.1 Temperature Measurement Points

The following is a list of measurement points and their temperatures. Maximum temperatures must not be exceeded at the worst case drive and system operating conditions with the drive reading and writing at the maximum system operations per second rate.

Note: "Temperature Measurement Points (bottom view)", shown in Figure 31, defines the modules that are located on the bottom side of the card and the measurement location on the bottom of the disk enclosure. Figure 32, "Temperature Measurement Point (top view)" defines where measurements should be made to determine the top disk enclosure temperature during drive operation.

---

<sup>9</sup> Guidelines for storage below 1 °C are given in IBM Technical Report TR 07.2112.

There must be sufficient air flow across the drive so that the disk enclosure and module temperature maximum limits defined in the following table are not exceeded.

	Absolute Maximum	Recommended Maximum
Disk Enclosure Top <sup>10</sup>	60/65 °C (140/149 °F)	50 °C (122 °F)
Disk Enclosure Bottom <sup>10</sup>	60/65 °C (140/149 °F)	50 °C (122 °F)
Channel Module <sup>11</sup>	95 °C (203 °F)	75 °C (167 °F)
SCSI Module	90 °C (194 °F)	70 °C (158 °F)
Microprocessor Module	80 °C (176 °F)	60 °C (140 °F)
Controller Module	90 °C (194 °F)	70 °C (158 °F)
Motor Driver Module	90 °C (194 °F)	70 °C (158 °F)

**Note:** Operating the drive above the absolute maximum temperatures may cause permanent damage

Table 31. Absolute Maximum and Recommended Maximum Operating Case Temperature Limits

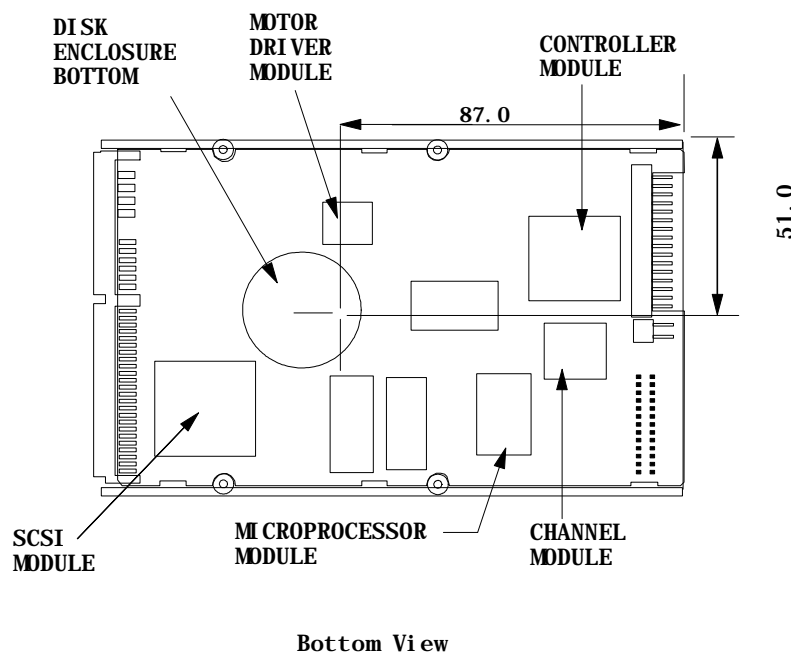

Fig 31. Temperature Measurement Points (bottom view)

<sup>10</sup> Absolute Maximum Disk Enclosure top or bottom is 60 °C for Ultrastar 18ZX and 65 °C for Ultrastar 9LZX.

<sup>11</sup> For continuous read applications the channel module will run at higher temperatures and will require additional cooling.

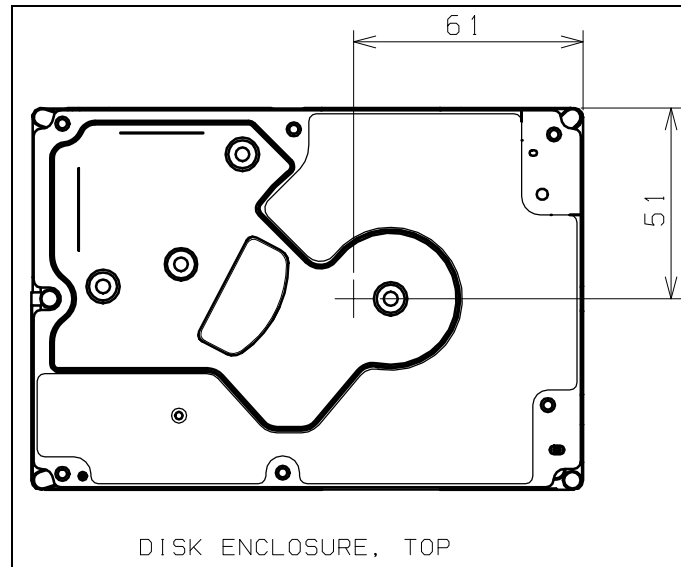

Fig 32. Temperature Measurement Point (top view)

**Notes:** When measuring module temperature

1. Center on the top surface of the module.
2. If copper tape is used to attach temperature sensors, it should be no larger than 6 mm square.

---

## 7.2 Vibration and Shock

The operating vibration and shock limits in this specification are verified in two mount configurations:

1. By mounting with the 6-32 bottom holes with the drive on 2 mm high by 10 mm diameter spacers as required by section 4.2, "Clearances".
2. By mounting on any two opposing pairs of the 6-32 side mount holes.

Other mount configurations may result in different operating vibration and shock performance.

The x, y and z axes of the drive are defined as follows. Referring to figure 1 in section 1, "ULTRASTAR 9LZX Disk Drive Assembly", the x-axis is defined as a line normal to the front/rear faces, the y-axis is defined as a line normal to the left side/right side faces, and the z-axis is normal to the x-y plane.

### 7.2.1 Output Vibration Limits

Spindle residual imbalance not to exceed 0.3 gram-millimeters.

### 7.2.2 Operating Vibration

The vibration is applied in each of the three mutually perpendicular axes, one axis at a time.

### 7.2.2.1 Random Vibration

For excitation in the x, y, and z directions, the drive will operate without hard errors when subjected to vibration levels not exceeding those defined in the following table.

**Note:** The RMS value in the table below is obtained by taking the square root of the area defined by the  $g^2/Hz$  spectrum from 5 to 500 Hz.

	5 Hz	500 Hz	RMS
Random Vibration	4.0E-03	4.0E-03	1.41
Units	$g^2/Hz$		g

Table 32. Random Vibration Levels (Operating)

### 7.2.2.2 Swept Sine Vibration

The drive will operate without hard errors when subjected to the swept sine vibration of 1.0 G peak from 5 to 500 Hz in the x, y, and z directions.

This measurement is taken during a frequency sweep from 5 to 500 Hz and back to 5 Hz. The sweep rate will be one Hz per second.

**Note:** 1.0 g acceleration at 5 Hz requires 0.78 inch double amplitude displacement.

## 7.2.3 Nonoperating Vibration

### 7.2.3.1 Random Vibration

No physical damage or degraded performance will occur as long as the vibration at the unpackaged drive, in the x,y and z directions (as defined in section 7.2, "Vibration and Shock"), does not exceed the levels defined in the following table. The test duration is 30 minutes in each of the three axes.

Class	5 Hz	500 Hz	RMS
Random Vibration	1.0E-02	1.0E-02	2.23
Units	$g^2/Hz$		g

Table 33. Random Vibration Levels (Nonoperating)

### 7.2.3.2 Swept Sine Vibration

No physical damage or degraded performance will occur as long as the vibration at the unpackaged drive, in the x,y and z directions (as defined in section 7.2, "Vibration and Shock"), does not exceed the levels defined in the following table.

The test will consist of a sweep from 5 Hz to 500 Hz and back to 5 Hz at a sweep rate of eight decades per hour.

Frequency	5 Hz to 7 Hz	7 Hz to 500 Hz
Amplitude	0.8 inch DA	2.0 g peak

Table 34. Swept Sine Vibration Levels

## 7.2.4 Operating Shock

No permanent damage will occur to the drive when subjected to a 10 G half sine wave shock pulse of 2 milliseconds duration. The shock pulses are applied in each of three mutually perpendicular axes, one axis at a time.

## 7.2.5 Nonoperating Shock

### 7.2.5.1 Translational Shock

For both the 1.0 and the 1.6 models, no hard error or acoustic degradation will occur if the unpackaged drive is subjected to a 20 milliseconds square pulse shock of 35 Gs or less applied to all three axes, one direction at a time.

For both the 1.0 and the 1.6 models, no hard error or acoustic degradation will occur if the unpackaged drive is subjected to a 180 in/sec velocity change square pulse shock of 50 Gs or less applied to all three axes, one direction at a time.

For the 1.0 models, no hard error or acoustic degradation will occur if the unpackaged drive is subjected to a 2 millisecond half sine pulse shock of 150 Gs or less applied to all three axes, one direction at a time.

For the 1.6 models, no hard error will occur if the unpackaged drive is subjected to a 2 millisecond half sine pulse shock of 140 Gs or less applied to all three axes, one direction at a time. No degradation in A-weighted idle sound power will occur if the unpackaged drive is limited to a 2 milliseconds half sine pulse shock of 70 g or less applied in the axial direction (z axis), or 140 g or less applied in the radial direction (x-y plane). The average A-weighted idle sound power will increase by 0.1 Bel if the unpackaged drive is subjected to a 2 milliseconds half sine pulse shock of 140 g in the axial direction (z axis).

### 7.2.5.2 Rotational Shock

The actuator will remain latched in the disk landing zone if the unpackaged drive is subjected to a 2 millisecond half sine wave shock less than 15,000 radians per second squared applied to the XY plane.

---

## 7.3 Contaminants

The corrosive gas concentration expected to be typically encountered is Subclass G1; the particulate environment is expected to be P1 of C-S 1-9700-000 (1/89).

---

## 7.4 Acoustic Levels

	Octave Band Center Frequency (Hz)							LwA
	125	250	500	1K	2K	4K	8K	
UltraStar 9LZX								
Idle	4.4	2.8	2.8	4.0	4.0	4.1	3.8	4.4
Operating	4.4	3.8	3.4	4.0	4.3	5.2	4.5	5.2
UltraStar 18ZX								
Idle	4.2	2.9	3.3	3.8	4.4	4.6	4.5	4.8
Operating	4.2	3.2	3.4	4.0	4.8	5.1	4.3	5.3

Table 35. Upper Limit Sound Power Requirements (LwAu Bels)

Additionally, the population average of the sound pressure measured one meter above the center of the drive in idle mode will not exceed 41 dBA.

### Notes:

1. The above octave band and A-weighted sound power levels are statistical upper limits of the sound power levels. See C-B 1-1710-027 and C-S 1-1710-006 for further explanation.
2. The drives are tested after a minimum of 20 minutes warm-up in idle mode.
3. The operating mode is simulated by seeking at a rate of 46 seeks per second.
4. The values for a sample size of 5 or greater will be less than or equal to the stated upper limits with 90% confidence.

## 7.5 Drive Mounting Guidelines

Listed below are summary points for mounting a drive in a user system. Additional information is available from IBM technical support.

1. The drives are sensitive to vibration in the plane of the disk. Vibration in this plane, referred to as rotational vibration, couples directly into offtrack. Mounting within using systems should minimize the rotational input to the drive mounting points due to external vibration.
2. Orient the spindle axis Parallel to the direction of minimum shock loading
3. Use of the extreme side mounts will align the drive Center of Gravity (CG) closer to the center of stiffness. This will minimize off axis coupling and in-plane yaw rotation about the spindle axis.
4. If any isolation between the device and the frame is to be used, it can be soft in the x,y,z, pitch and roll axis but should be stiff for the yaw axis. Yaw motion is rotation about the spindle axis which couples directly into off-track.
5. If isolators are used, they should provide natural frequencies about 25% lower than the motor speed. The idea is to place the rigid body modes below primary excitation frequencies and drive structural modes. Isolators must be well damped and of sufficient strength so they will not be torn by high nonoperational shocks.
6. Keep the rigid body resonances of the drive away from harmonics of the spindle speed.  
10020 RPM harmonics: 167Hz, 334Hz, 501Hz, 668Hz....
7. It is desirable that the carrier be as stiff as possible while allowing room for the isolator mounts (if used). Rather than creating a weak carrier that flexes to fit the drive, hold the mounting gap to tighter tolerances. A flexible carrier may contain resonances that cause operational vibration and/or shock problems.
8. If isolators are to be used, design for maximum sway. Adequate clearance around all edges are necessary for cooling and shock impacts. Maximum sway is usually determined by geometry and compressibility limits of the isolator grommet plus some carrier/rack flexibility. Metal to metal impacts must be avoided because they result in short duration, high impact loads; such waveforms can excite high frequency modes of the components inside the drive.
9. To minimize acoustic radiation, mount drives so there is no "line of sight" between a drive and user.

---

## 7.6 Drive/System Compatibility

ULTRASTAR 9LZX/18ZX drives are supplied to using systems that demonstrate a level of drive/system compatibility to this specification.

Verification prior to a formal system qualification is recommended to determine whether the drive/system is capable of achieving the quality and reliability requirements found in this specification.

Preliminary testing to verify compatibility may be performed using common laboratory instrumentation equipped with the appropriate transducer (thermal, power, shock, vibration and acoustics). Final verification must be performed by measuring functional performance (error rates) of the drive when installed within the system.

The following sections describe the parameters to be verified prior to and as a part of the system qualification test in order to achieve the quality and reliability requirements set forth by this specification.

**Power**

The system must be capable of providing adequate power to the drive as described in section 2.4, "Power Requirements". In addition to voltage, current and capacitance, the system must be capable of remaining within regulation when the maximum number of drives are installed in the system.

Special consideration must be given to systems designing for hot plug capabilities. Refer to section 2.4.8, "Hot Plug/Unplug' Support" of this specification for requirements and guidelines.

**Thermal**

The system must supply adequate cooling and air flow to maintain casting and module temperatures listed in section 7.1, "Environmental". The system must demonstrate sufficient cooling to operate below the recommended temperatures for any given location that the drive may be installed within the system.

Special consideration for minimum clearances must be given to achieve adequate cooling of the drive.

**Shock (Operating and Non-operating)**

The system must maintain an environment that is compatible with operating and nonoperating shock specifications found in section 7.2.4, "Operating Shock" and in section 7.2.5, "Nonoperating Shock". Both operating and nonoperating shock should be measured in all three planes and found to be within the limits set in this specification.

**Vibration (Operating and Non-operating)**

The system must maintain an environment that is compatible with the operating vibration specification found in section 7.2.2, "Operating Vibration". This must include both random and swept sine vibration and the vibration must be measured in all three planes.

Drives are sensitive to rotary vibration. Mounting within the using systems must minimize the rotational input to drive mounting points due to external vibration.

To achieve system compatibility for vibration, it is recommended that the system conform to section 7.5, "Drive Mounting Guidelines".

**Electromagnetic Compatibility (EMC)**

The system must be designed to insure that stray fields are not placed close to the device. Minimum clearances must be maintained. Clearance guidelines are found in section 4.2, "Clearances".

**Electrostatic Discharge (ESD)**

The drive contains electrical components sensitive to ESD. System design and assembly process, must protect the drive and must be verified to conform the protection, care and handling guidelines found in section 7.10, "ESD Protection and Handling".

**Interface Compatibility**

The drive/system, in conjunction with associated operating software, must be capable of conforming to the pin configurations, cabling, command and timing parameters found in section 5, "Electrical Interface".

Verification of the preceding parameters is recommended prior to starting a system test or qualification. Most parameters may be verified by using common laboratory instrumentation or simple inspection of design, handling and process. For further information regarding verification testing, please contact your technical support representative.

Final verification of drive/system compatibility must be determined through functional testing. Adequate system testing must be performed to demonstrate conformance to the Data Reliability requirements, reference section 6.2, "Data Reliability".

---

## 7.7 Recommendations for Handling of Disk Drives

Disk drives are very fragile and can be damaged if dropped or impacted against another object. Amount of damage to the drive will depend on magnitude and duration of the impact. People handling the disk drive should be trained in the proper handling procedures. Manufacturing processes, equipment, and disk drive holding containers/fixtures should be characterized and qualified to less than 50 Gs in the manufacturing environment. The following are things to consider in the handling and protection of the disk drive.

Damage may be caused by:

- Dropping a drive onto a hard surface, even over small distances
- Drives may fall over after being set on edge
- Tapping a drive with a screw driver tip or other hard implement
- Tapping a drive into position when installing into a user frame
- Clicking 2 drives together metal to metal

Precautions to take during handling:

- Wear ESD protection at all times
- Treat drives as you would "Eggs" or "Glass Stemware"
- Handle one drive at a time
- Handle drive by the sides only, avoid grasping the card
- Replace drive into original packaging for transport
- Pad ALL drive work areas (1" foam under 1/4" ESD pad)
- Pad ALL drive transport areas (1" foam under 1/4" ESD pad)
- Pad All drive holding areas (1" foam under 1/4" ESD pad)
- Clear work areas of potential metal contact
- Remove / Install drives separately
- Report any drive that may have been dropped or mishandled
- Do Not stack disk drives (Even in ESD Bags)
- Do Not contact drive or card with tooling (drivers, etc)
- Do Not rush installation
- Do Not "Slam" a drive into a carrier or frame
- Do Not "Seat" a drive into place with tooling
- Do Not stand a drive on end or side (Tipping Hazard)
- Do Not allow drives to contact each other

Shipping Handling Precautions:

- Check for and report shipping damage to a pallet
- Do Not stack more than 2 pallets
- Do Not contact pallet package with Forklift Forks
- Do Not drop a Pallet
- Do Not drop Drive Boxes (Singles or Multiples)

## 7.8 Breather Filter Hole

Under no circumstances should the Filter Breather Hole be obstructed or labels placed over the hole.

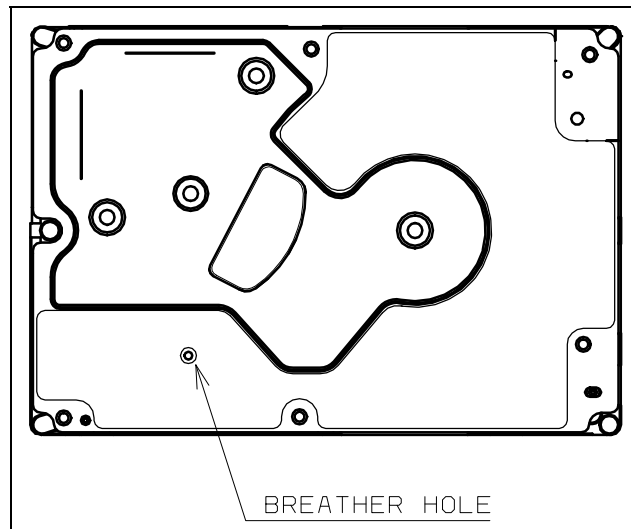

Fig 33. Breather Hole for Filter

## 7.9 Periodic Maintenance

None required.

## 7.10 ESD Protection and Handling

The ULTRASTAR 9LZX/18ZX disk drives contain electrical components sensitive to damage due to electrostatic discharge (ESD). Proper ESD procedures must be followed during handling, installation, and removal of the drives.

Precautions such as using ESD protective shipping containers, ESD mats, wrist straps and grounding all surfaces that are allowed to touch or come close to the device are recommended.

Known ESD dangers such as walking across a carpet carrying the device should be avoided. It is recommended that the device is always stored in its anti-static package until it is ready for installation.

## 7.11 Stray Magnetic Fields

This device is sensitive to strong magnetic fields. Magnets and other sources of magnetic fields must not be placed close to the device. To avoid problems associated with stray field magnetic susceptibility the field strength, at these frequencies, at the drive mounting location, must be equal to or below the values shown in the following table.

Frequency	DC (Static Field)	47 to 400 Hz	400 Hz to 5 kHz	5 to 50 kHz	50 to 200 kHz
Magnitude (Gauss)	5	5	2	0.5	0.1

Table 36. Stray Magnetic Field Strength

---

## 8 Standards

---

### 8.1 Safety

- **UNDERWRITERS LABORATORY (UL) APPROVAL:**

The product is approved as a Recognized Component for use in Information Technology Equipment according to UL 1950 Standard, third edition (without any D3 deviations). The UL Recognized Component marking is located on the product.

- **CANADIAN STANDARDS ASSOCIATION (CSA) APPROVAL:**

The product is certified to CAN/CSA-C22.2 No. 950-M95 Third Edition (without any D3 deviations). The CSA certification mark is located on the product.

- **FLAMMABILITY REQUIREMENTS**

Printed circuit boards and all foam and other plastic materials are UL Recognized V-1, HF-1, or VTM-1 or better. Small plastic parts that will not contribute to a fire will meet V-2 flame class.

- **SAFE HANDLING:**

The product is conditioned for safe handling in regards to sharp edges and corners.

- **ENVIRONMENT:**

IBM will not knowingly or intentionally ship any units which during normal intended use or foreseeable misuse, would expose the user to toxic, carcinogenic, or otherwise hazardous substances at levels above the limitations identified in the current publications of the organizations listed below.

- International Agency for Research on Cancer (IARC)
- National Toxicology Program (NTP)
- Occupational Safety and Health Administration (OSHA)
- American Conference of Governmental Industrial Hygienists (ACGIH)
- California Governor's List of Chemical Restricted under California Safe Drinking Water and Toxic Enforcement Act 1986 (Also known as California Proposition 65)
- IBM Environmental Design Engineering Specification 46G3772

- **SECONDARY CIRCUIT PROTECTION REQUIRED IN USING SYSTEMS**

Care has been exercised to not use any unprotected components or constructions that are particularly likely to cause fire. However, adequate secondary over current protection is the responsibility of the user of the product. Additional protection against the possibility of sustained combustion due to circuit or component failure may need to be implemented by the user with circuitry external to the product. Over current limits of the voltage into the drive of 10 amps or less should be sufficient protection Electromagnetic Compatibility (EMC).

## 8.2 Electromagnetic Compatibility (EMC)

- FCC Requirements

Pertaining to the ULTRASTAR 9LZX/18ZX disk drive, IBM will provide technical support to assist users in complying with the United States Federal Communications Commission (FCC) Rules and Regulations, Subpart B Digital Devices "Class A and B Limits". Tests for conformance to this requirement are performed with the disk drive mounted in the using system.

- CISPR 22 Requirements

Pertaining to the ULTRASTAR 9LZX/18ZX disk drive, IBM will provide technical support to assist users in complying with the Comite International Special des Perturbations Radio Electriques (International Special Committee on Radio Interference) CISPR 22 "Class A and B Limits" .

- European Declaration of Conformity.

The ULTRASTAR 9LZX/18ZX disk drive has been tested to comply with the European Council Directive 89/336/EEC and thereby bears the "CE" Mark of Conformity.

Pertaining to the ULTRASTAR 9LZX/18ZX disk drive, IBM will provide technical support to assist users in complying with the European Council Directive 89/336/EEC so the final product can thereby bear the "CE" Mark of Conformity.

This is obtained by integrating the drives in an IBM product. Producers integrating these drives in alternative enclosures will still need to test the system to ensure it complies with the European Directive.

- Australian Declaration of Conformity

The ULTRASTAR 9LZX/18ZX disk drives have been tested to comply with AS/NZS 3548 and thereby bears the "C-Tick" Mark of Conformity.

Pertaining to the ULTRASTAR 9LZX/18ZX disk drives, IBM will provide technical support to assist users in complying with AS/NZS 3548, so the final product can thereby bear the "C-Tick" Mark of Conformity.

This is obtained by integrating the drives in an IBM product. Producers integrating these drives in alternative enclosures will still need to test the system to ensure it complies with AS/NZS 3548.