



Installation guide  
**Ultrastar 36XP**  
Multi-mode SE/LVD

Models: DRHS-36V  
DRHS-36D



---

**Table of contents**

---

<b>Introduction</b>	Page 3
<b>Hardware description</b>	Page 4
<b>Hard disk drive handling guide</b>	Page 5
<b>Hard disk drive installation flow chart</b>	Page 6
<b>Step 1: Installation checklist</b>	Page 7
<b>Step 2: Prepare for installation</b>	Page 9
<b>Step 3: Jumper Settings</b>	Page 9
<b>Step 4: Mounting</b>	Page 11
<b>Step 5: Connectors</b>	Page 12
<b>Step 6: Complete physical installation</b>	Page 13
<b>Step 7: Installation and configuration</b>	Page 13
<b>Step 8: FDISK</b>	Page 16
<b>Step 9: Formatting</b>	Page 18
<b>Step 10: Operating system installation</b>	Page 19
<b>Appendix</b>	Page 20
<b>Glossary</b>	Page 25

## **Introduction**

---

This manual was prepared to help you install your IBM Ultrastar 36XP hard drive in most computer systems. If you do not feel comfortable installing this drive yourself, contact a qualified installer to assist you.

International Business Machines Corporation provides this publication "AS IS" without warranty of any kind, either express or implied, including, but not limited to, the implied warranties of merchantability or fitness for a particular purpose. Some states do not allow disclaimers of express or implied warranties in certain transactions. Therefore, this statement may not apply to you.

This publication could include technical inaccuracies or typographical errors. Product data and specifications are subject to change without notice. Changes are periodically made to the information herein; these changes will be incorporated in new editions of the publication. IBM may make improvements and/or changes in the product(s) and/or the program(s) described in this publication at any time.

It is possible that this publication may contain reference to or information about IBM products (machines and programs), programming, or services that are not announced in your country. Such references or information must not be construed to mean that IBM intends to make available such IBM products, programming, or services in your country.

Product description data contained herein represents IBM's design objectives and is provided for comparison among IBM products; actual results may vary based on a variety of factors. Except as explicitly stated in the Warranty section of this Guide, the product data contained herein does not constitute a warranty. Questions regarding IBM warranty terms or the methodology used to derive data should be referred to an IBM representative.

Technical information about IBM hard disk drive products can be obtained via the Internet at: <http://www.ibm.com/harddrive> or by calling the IBM Hard Disk Drive Technical Support Center at 888.426.5214.

**©Copyright International Business Machines Corporation 1999. All rights reserved.** Note to US Government Users - Documentation related to restricted rights - Use, duplication, or disclosure is subject to restrictions set forth in GSA ADP Schedule Contract with IBM Corp.

IBM is a registered trademark of the International Business Machines Corporation. The following are also trademarks or registered trademarks of the International Business Machines Corporation in the United States, other countries, or both: Ultrastar and OS/2. Any other products or trademarks are the property of their respective owners.

---

## Hardware description

---

The Ultrastar 36XP is available in various models with the following options:

- { Capacity of 36GB
- { 68 pin or 80 pin (SCA) connectors
- { 68 pin SCSI connectors use the SCSI P connector which supports wide data transfers
- { 80 pin SCSI connectors use the SCA-2 connector

Capacity	Model	SCSI Pins/Connector Type	SCSI Electrical Signal Type
36GB	DRHS-36V	68 / Unitized Connector	Low Voltage Differential (Ultra2)
36GB	DRHS-36V	80 SCA-2	Low Voltage Differential (Ultra2)

These drives offer an advanced LVD interface that supports transfer rates of up to 80 MB/sec. To take advantage of the higher transfer rate of 80 MB/sec, your computer will need to have a controller that supports the LVD interface. If you have a SCSI controller that does not support this interface, the drive will still function, but will be limited to data transfer speeds significantly lower than 80MB/sec due to the lower speed of your controller. If you have a slower controller, you may wish to purchase an LVD controller card to take advantage of Ultrastar's 80 MB/sec data transfer rate. An LVD controller card will fit into any available slot in your computer.

If you currently have wide SCSI drives (single-ended) and a non-LVD controller, you may still attach the LVD model Ultrastar 36XP to the existing cable. However, single-ended wide SCSI drives cannot be added to the same bus as an LVD drive if that bus is connected to an LVD controller.

To determine if your current controller card is LVD, see the documentation that came with your controller or contact the controller manufacturer for this information.

These drives are 3.5" drives designed to work in NT and Unix workstations and servers. They are ideal for use by video producers and movie editors. The Ultrastar 36XP family is designed to work with MMX systems. Compatibility listings are included in the appendix. Before you begin installation, please read the "Hard disk drive handling guide" on the following page.

---

## Hard disk drive handling guide

---



These notes are designed to provide a simple overview of the need for caution when handling a disk drive.

*Disk drives can be easily damaged by electrical static shock or rough handling.* In order to minimize the risk of damage to a disk drive, it is essential that the drive be handled while resting on a cushioned surface (which is electrostatically safe). Many such static safe mats are available, examples are 3M's 8210 table mat or 3M's "First Touch" computer pad.

*Great care should be taken when handling disk drives.* Do not bump them against any object. When attaching brackets or mounting the drive in the computer, be very careful. It is *very easy* to unintentionally introduce shocks which exceed specifications.

Please note that the capacity of each disk drive to withstand electrical or mechanical shock varies according to its design. The IBM Hard Disk Drive Technical Support Center can advise you on the suitability of your Ultrastar drive for a specific application.

Damage incurred to a drive might not be immediately evident and could cause the drive to fail long after the damage occurred.

---

## Hard disk drive installation flow chart

---

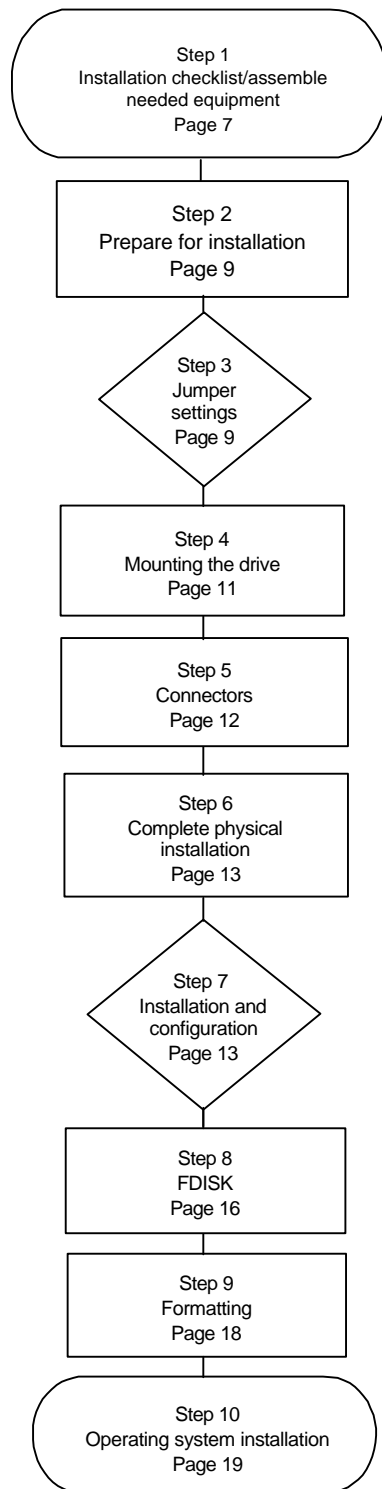

---

## Step 1: Installation checklist

---

To install the Ultrastar drive you may need the following items, depending on your computer's components:

- 1) \_\_\_ The installation kit (as shown in the diagram below) containing the Ultrastar drive, 4 mounting screws, and any related publications. Save the box the drive came in.

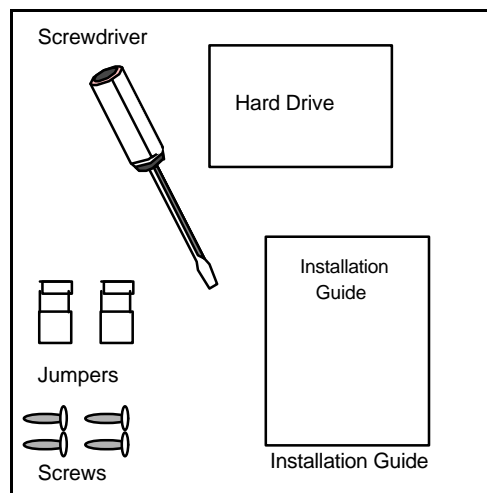

- 2) \_\_\_ The documentation that came with your computer or storage enclosure.
- 3) \_\_\_ A small, flat-blade screwdriver.
- 4) \_\_\_ A SCSI controller, which is either built-in or an adapter inside your computer, and any related documentation.
- 5) \_\_\_ Mounting brackets, if required for your computer. Contact your place of purchase if you are unsure if mounting brackets are required.
- 6) \_\_\_ A bootable DOS diskette. (See the section entitled *Making a bootable diskette* in the appendix.)
- 7) \_\_\_ If you are replacing an older internal drive with the new Ultrastar drive and want to copy all of the files from the older drive to the new drive, you may need additional software. (See the section entitled *Drive copy* in the Appendix.)

Continue installation with the following procedures:

- 1) \_\_\_ Backup your existing drive to avoid any loss of data during installation. (See the section entitled *Backup and restore* in the Appendix.) After completing backup, shut down as normal.
- 2) \_\_\_ Unplug your system from the electrical outlet.
- 3) \_\_\_ Discharge static electricity by establishing a common voltage between your body and the hard drive. Simultaneously touch an unpainted metal surface on the outside of your computer system with your bare hands and the hard drive in its anti-static bag. Avoid excessive movement until the drive has been mounted.

*IBM storage products*

4) \_\_\_ DO NOT LOW-LEVEL FORMAT YOUR DRIVE! IBM drives are low-level formatted by the manufacturer and reformatting may cause permanent damage to your drive and your system. (See the section entitled *Utilities* in the Appendix.)

5) \_\_\_ Record the following information:

Drive Model \_\_\_\_\_

Drive P/N \_\_\_\_\_

Serial # \_\_\_\_\_

Date of Purchase \_\_\_\_\_

Place of Purchase \_\_\_\_\_

---

## Step 2: Prepare for installation

---

### Opening your computer

1. Turn the system off.
2. Unplug the power cord from the wall outlet.
3. Remove all cables from the back of your computer, labeling them if necessary.
4. Remove the cover from your computer. (Consult your user's guide for instructions if needed.)

### Unpackaging your hard drive

1. Remove the drive from the anti-static package that it was shipped in.
2. Handle the drive by the sides only.
3. Do not touch the main computer chip board.
4. Do not drop. A drop from *only 1/4 inch* could permanently damage your hard drive.
5. If available, use an ESD (Electronic Static Discharge) wrist strap while handling your drive.
6. Place the drive carefully on a static free area.

---

## Step 3: Jumper settings

---

The jumper settings are found on the hard drive on the opposite end of the interface connector (see diagram page 12). They are physical settings that must be changed for different uses of a hard drive.

### SCSI ID Jumpers

Each SCSI device will need to have its own SCSI ID. You can use ID 0 through ID 15, reserving ID 7 for your controller card. Follow the table below to set an ID on your SCSI drive.

Bit 3	Bit 2	Bit 1	Bit 0	Address
off	off	off	off	0
off	off	off	on	1
off	off	on	off	2
off	off	on	on	3
off	on	off	off	4
off	on	off	on	5
off	on	on	off	6
off	on	on	on	7*
on	off	off	off	8
on	off	off	on	9
on	off	on	off	10
on	off	on	on	11
on	on	off	off	12
on	on	off	on	13
on	on	on	off	14
on	on	on	on	15

\*Reserved for controller card

SCSI Address Determination

### Drive Termination

The SCSI bus will need to be terminated at both ends of the bus. The Ultrastar 36XP does not have onboard active termination. You will need to supply an external Ultra2 compatible terminator.

### Termination Power

Some controllers may require the drive to supply 5 volts of power to the bus to aid termination. If your controller requires this, place a jumper on the Termination Power Enable jumpers to the side of the jumper block. These pins require a 2.54mm jumper shunt.

### Auxiliary Option Jumper Block

The 68 pin models contain an auxiliary connector that replicates some of the functions provided by the front option jumper block. The auxiliary connector should only be used if you have a combination "ganged" switch, typically found in external drive enclosures. The front option block and the auxiliary option block may not be used simultaneously.

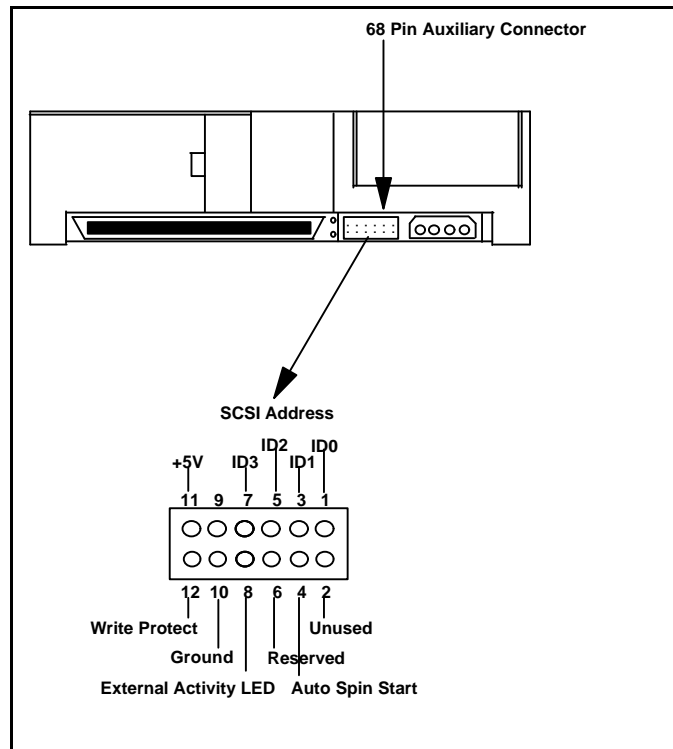

### Additional Jumper Options

The Ultrastar drives offer additional options on the jumper block. See Appendix for details of the additional jumper options shown below.

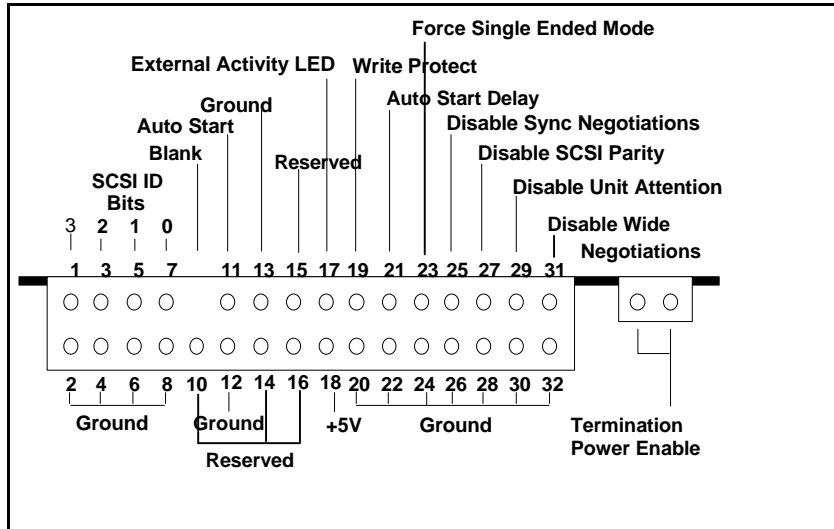

### Step 4: Mounting

After setting the jumpers, mount the hard drive in your system. The Ultrastar drive can be mounted with any of its six surfaces facing down (right side up, upside down, sideways, etc.). See below for mounting hole locations.

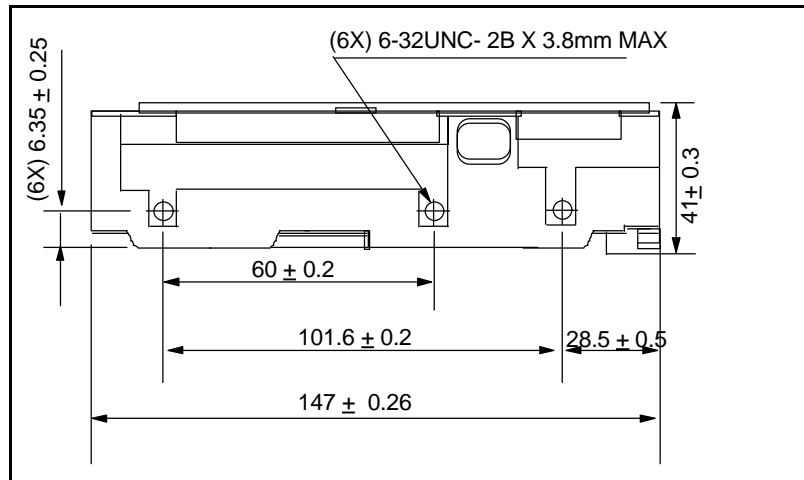

Side mounting holes

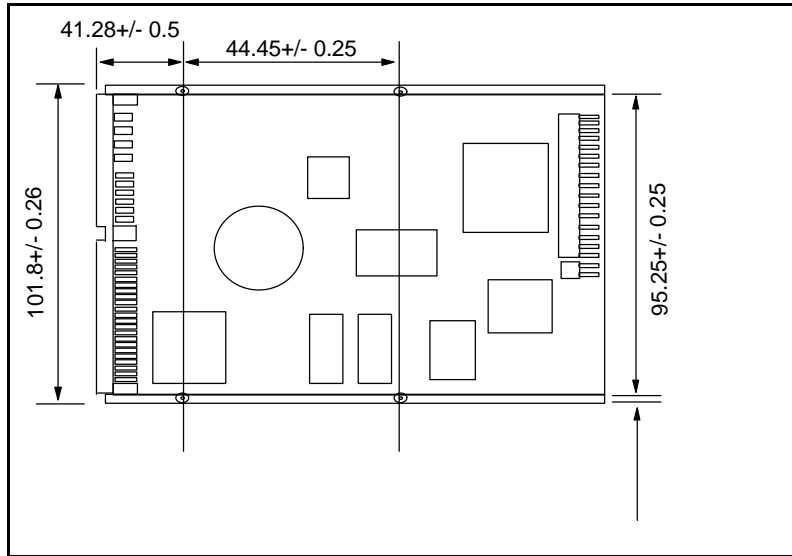

Bottom mounting holes

You must ensure that the drive has sufficient air flow. Mount the drive in the system using 4 6-32 UNC screws. The maximum screw length is 3.5 mm for the side holes and 6 mm for the bottom holes. Mount the drive securely enough to prevent excessive motion or vibration.

If you are mounting your drive in a 5 inch bay, you may need to purchase mounting brackets from your computer manufacturer for the drive to be mounted securely.

---

**Step 5a: Connectors (68 pin drives)**

After the drive has been carefully mounted, connect the SCSI cable and the power cable to the drive. (Note that the SCSI connector and power connector are keyed for proper insertion.)

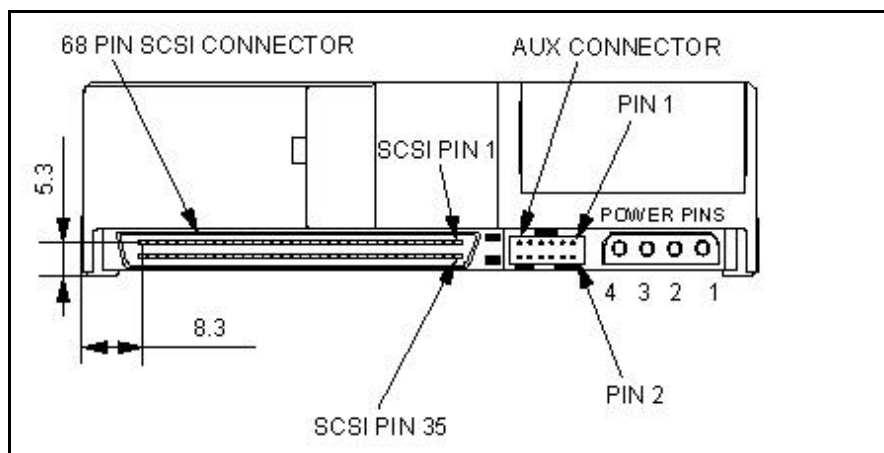

68 pin connector

---

### Step 5b: Connectors (80 pin drives)

---

80 pin drives are to be plugged into backplanes of servers and require no cables. If you have an 80 pin drive that you want to connect to a 68 pin SCSI cable, you will need to purchase a converter.

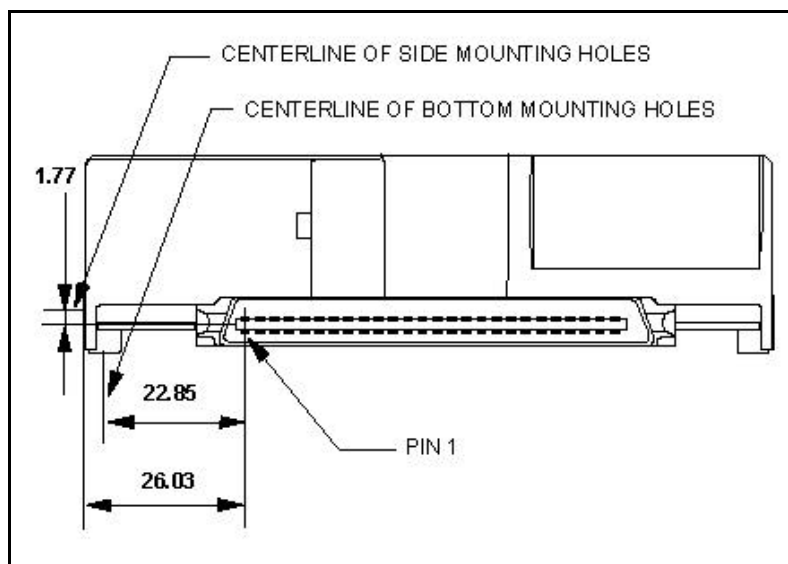

80 pin connector

---

### Step 6: Complete physical installation

---

Verify that the cable is properly connected to the SCSI controller. Replace the cover on the computer, connect all cables, and plug the power cord into the wall.

---

### Step 7: Installation and configuration

---

If you have just added a SCSI controller card, follow the manufacturer's instructions to install the card.

#### Boot computer

"Booting" means turning on your computer. Turn on your computer after you have inserted a bootable diskette. You should see the drive listed when the system is booting.

*Note: The example on the next page uses the Adaptec 3950U2 controller and the Model DRVS-09D drive.*

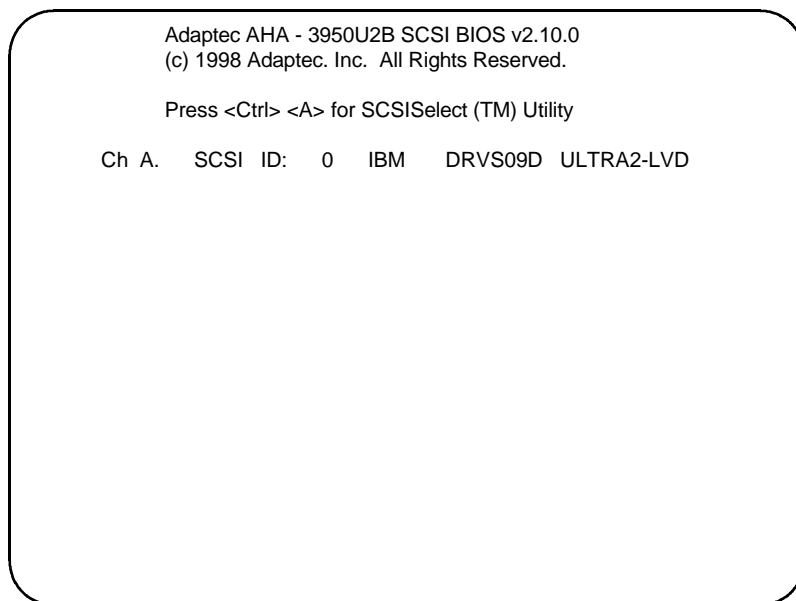

You can, at this time, press [CTRL] [A] to enter the Adaptec SCSI setup utility. The following screen will appear.

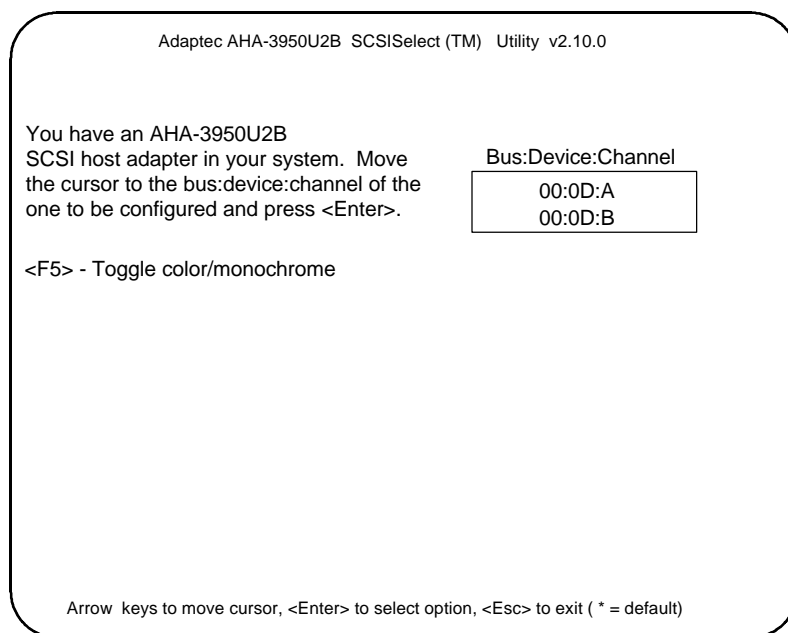

Select the channel to which your drive is attached. The screen on the next page will follow.

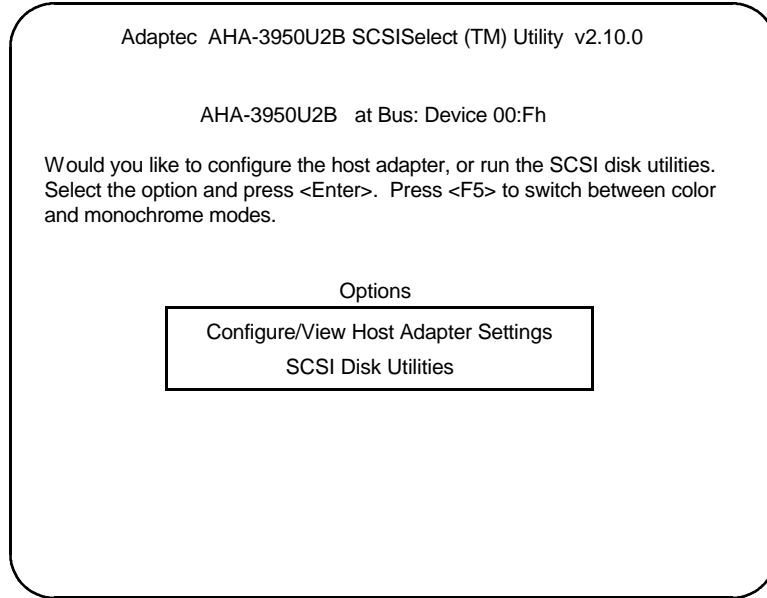

Select the first option *Configure/View Host Adapter Settings*. The next screen is shown below with the default settings.

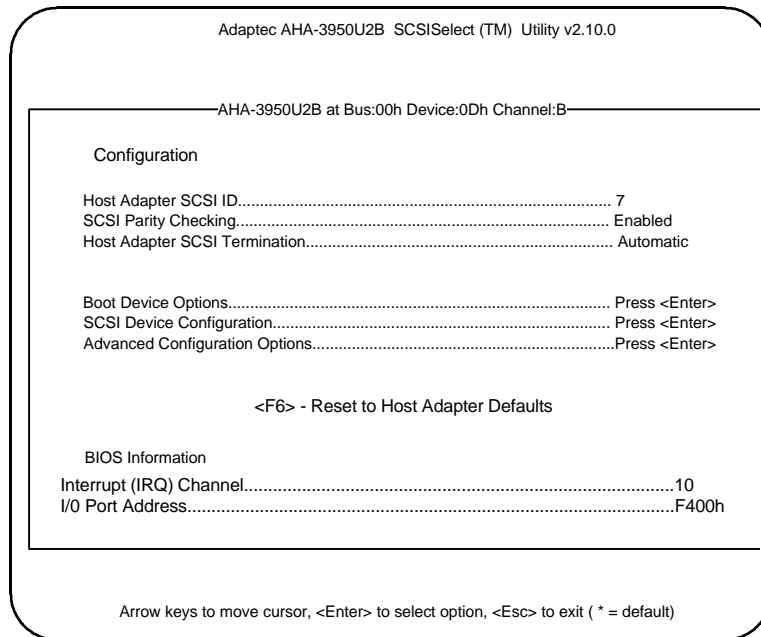

You can accept the default settings with *Host Adapter SCSI Termination* set to Automatic. If you wish to accept the default settings, press [ESC] to return to the previous menu. Select the SCSI utilities.

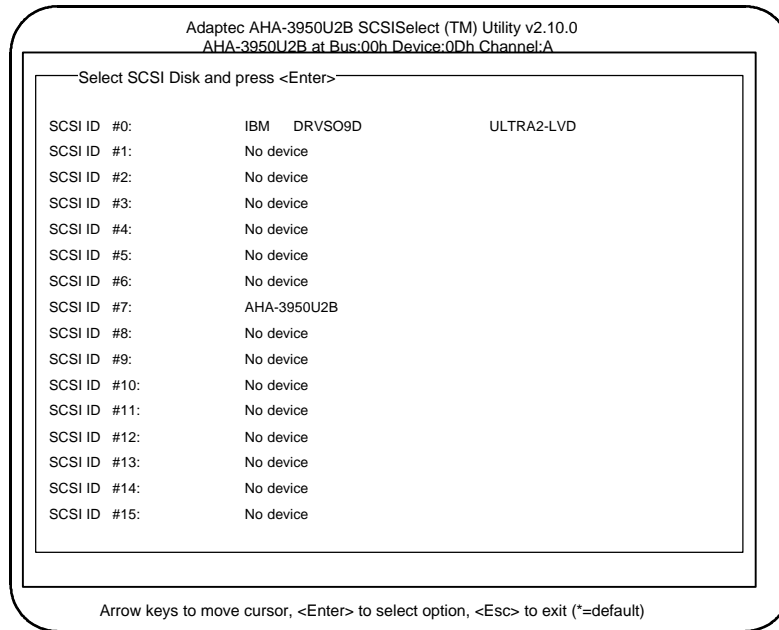

This shows all devices attached to the Bus. To perform a *Verify Media*, highlight the drive you would like to verify and press [ENTER]. Select *Verify Media* from the options.

If you wish to accept all settings, press [ESC] to exit out of the Adaptec settings.

---

### Step 8: FDISK

---

Boot to a bootable diskette and type FDISK at the A:\ prompt. If Windows® 95 OSR2 or Windows® 98 are used, the following screen will appear.

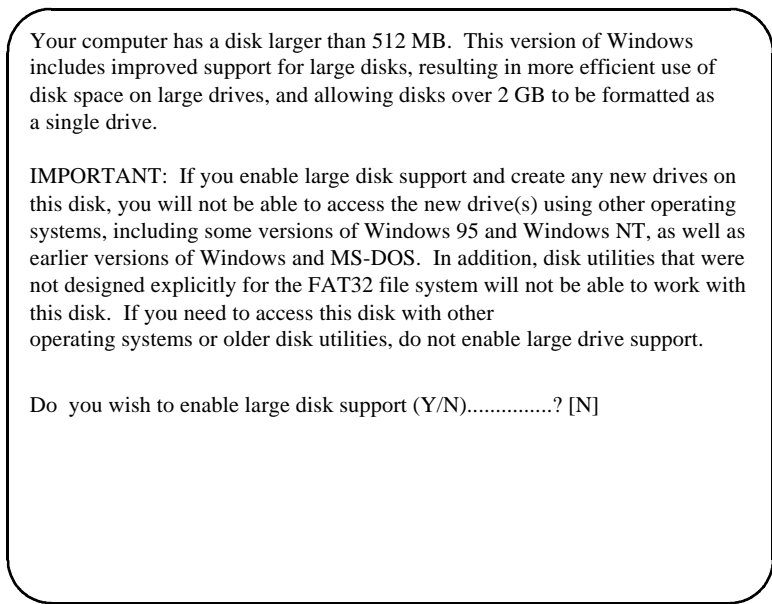

## IBM storage products

Type *Y* to select the FAT 32 file system. Type *N* to select the FAT 16 file system.

The following screen allows you to create partitions. If you have more than 1 drive there will be 5 options. Option 5 allows you to select the drive you wish to partition.

```
PC DOS Version 7.0
Fixed Disk Setup Program
Copyright IBM Corporation 1983-1994

FDISK Options

Current fixed disk drive:          1

Choose one of the following:

1. Create DOS partition or Logical DOS Drive
2. Set active partition
3. Delete partition or Logical DOS Drive
4. Display partition information
5. Change current fixed disk drive

Enter choice:[1]

Press ESC to exit FDISK
```

Select option 1 to create a DOS partition. The screen below will appear.

```
Create DOS Partition or Logical DOS Drive

Choose one of the following:

1. Create Primary DOS Partition
2. Create Extended DOS Partition
3. Create Logical DOS Drive(s) in the Extended DOS partition.

Enter choice: [3]

Press ESC to return to FDISK Options
```

Select option 1 to *Create a Primary DOS Partition*. If this is to be the boot drive, set this partition to "Active".

## IBM storage products

Press *ESC* to return to the FDISK options. Create an *Extended DOS Partition* by selecting option 1 from the main menu and option 2 from the second menu. (Both menus shown above.)

Note: The Maximum Capacity shows only 8455 MB instead of 9130 MB. This is because the BIOS of some systems recognizes a Megabyte as 1,048,576 bytes (binary). Drive manufacturers recognize a Megabyte as 1,000,000 bytes (decimal). The capacities are the same in actual number of bytes.

After creating the *Extended DOS Partition*, press *ESC* to return to the FDISK main menu. Select option 1 to create a *Logical DOS Drive*, then option 3 to create a *Logical DOS Drive in an Extended Partition*.

```
Create Logical DOS Drive(s) in the Extended
                        DOS Partition

No logical drives defined

Total Extended DOS Partition size is 1047 Mbytes
      (1 MByte = 1048576 bytes)

Maximum space available for logical drive is 1047Mbytes (100%)

Enter logical drive size in Mbytes or percent of disk space (%).....[1047]

Press ESC to return to FDISK Options
```

Press *ESC* to return to FDISK and press *ESC* again to restart the system. You must restart the system for the partitions to be recognized.

---

### Step 9: Formatting

---

The drive will need to be formatted before an operating system can be loaded. Format the Primary partition and any Extended partitions that have been made.

After booting from a bootable diskette, run FDISK, option 4 to display the partition information. This is helpful to review drive letter assignments. Note the drive letters to ensure proper formatting.

Press *ESC* to return to the main menu and exit FDISK. At the A:\ prompt type *format x: /s* (where x is the drive letter). The */s* option will make your hard drive bootable by copying the system files to the hard drive. If you do not want this drive to be bootable, do not use the */s* command. You will see the following warning:

```
WARNING: ALL DATA ON NON-REMOVABLE DISK
DRIVE C: WILL BE LOST!
Proceed with Format (Y/N)?
```

## *IBM storage products*

Type Y for yes. There should be no data on the new drive. The time it takes to format the drive is dependent upon its size. When the drive has finished formatting, format the next logical drive, in this case D: by typing *format d:* You will get the same message. Select Y.

### **File Systems**

#### **FAT 16/FAT 32** (File Allocation Table)

The file allocation table is a group of sectors in a hard drive that contains address chains for the different files on a hard disk drive. There are usually two FATs (kept in different locations) on a hard drive. FAT32 is available in the Windows® 95 & Windows® 98 operating systems. FAT32 receives its designation because it allows 32 bits of addressing as opposed to 16 bits in the FAT16 file system.

#### **HPFS** (High Performance File System)

HPFS is the file system used by the OS/2 operating system.

#### **NTFS** (NT File System)

NTFS is an advanced file system used by Windows® NT.

---

### **Step 10: Operating system installation**

---

After the drive has been formatted, install an operating system. You may encounter the following issues.

#### **Windows® 95 / Windows® 98**

In Windows® 98 the system may hang-up when trying to self-restart. A reset or power cycle is required.

*Note: Some controllers, systems, or operating systems may expect ANSI SCSI-2 devices. The Ultrastar 36XP reports itself as a SCSI-3 device. Contact the IBM Hard Disk Drive Technical Support Center for a fix if you encounter this issue.*

---

## Appendix

---

### Making a bootable diskette

If you do not have a DOS bootable diskette, you may want to make one. This will be necessary for installing your new hard disk drive and in case of system failure. The DOS bootable diskette will contain files necessary to boot your system. These files are called system files. You will also want some utilities on your bootable diskette. Following are the instructions needed to add both the system files and the other helpful utilities.

- 1) Make sure your computer is on and you insert a diskette in drive A.
- 2) At the C:\ prompt, type *FORMAT A: /S* and press ENTER
- 3) Press [ENTER] again, unless you want to label your diskette.
- 4) Add the utilities. To do so, use some simple copy commands.
  - a) Type *cd Windows* at the C:\ prompt, press [ENTER].
  - b) Type *copy fdisk.exe a:*, press [ENTER].
  - c) Type *copy format.com a:*, press [ENTER].
  - d) Type *copy sys.com a:*, press [ENTER].
  - e) Type *copy chkdsk.exe a:*, press [ENTER].
  - f) Type *copy debug.exe a:*, press [ENTER].
- 5) Type *cd*.
- 6) Remove diskette from drive A:
- 7) Write protect the diskette by sliding the small plastic tab on the diskette in the up position.
- 8) Test the diskette.
  - a) Turn off your computer.
  - b) Insert the diskette in drive A:
  - c) Turn on your computer.
  - d) When you get to the A:\ prompt *type c:*, press [ENTER].
- 9) If any of these steps did not work, start again at step 1.

### Jumper block information

The jumper block is a block of pins located on the hard drive. When these pins are shorted with shunts (jumpers), the drive will behave in certain ways. A shunt is a small piece of plastic with metal inside that shorts out the connection between 2 pins when placed over them. These can be purchased at any local computer store. The pin pitch for all pins except for Termination Power is 2 mm. Termination Power pins have a pitch of 2.54mm.

#### **Auto Start Delay**

The Auto Start and Auto Start Delay pins control when and how the drive can spin up and come ready. When configured for Auto-Startup, the motor spins up after a SCSI reset without the need of a SCSI Start Unit command. For no Auto-Startup, a SCSI Start Unit command is required to

make the drive spin and be ready for media access operations. When in Auto-Start Delay mode, the drive will delay its start time by a period of time multiplied by its SCSI address.

***External Activity (LED) Pins***

The LED pins can be used to drive an external Light Emitting Diode.

***Write Protect Pin***

If the Write Protect pin is jumpered to ground the drive will prohibit SCSI commands that alter the customer data area portion of the media from being performed.

***Disable Synchronous Negotiation Pin***

If a Disable Target Initiated Synchronous Negotiation pin is grounded then a host initiator is required to start a negotiation handshake if wide transfers (16 bit) are desired.

***Disable SCSI Parity Pin***

Grounding this pin will disable SCSI parity checking.

***Disable Unit Attention Pin***

Grounding this pin will disable the drive from sending Unit Attention Sense information for commands immediately following a Power On Reset or SCSI Bus Reset.

***Disable Wide Negotiations***

Jumpering the pins will cause the drive to operate in single byte mode. The drive will not negotiate wide operation.

***Force Single Ended Mode***

Jumpering pin 23 to pin 24 will cause the 68 pin and 80 pin SCA LVD drives to operate in single ended mode only. The drive will not use the DIFFSENS line to determine SE or LVD modes

**Controller information**

The examples in this guide have used an Adaptec controller. You may have a chipset embedded into your motherboard. If this is the case, plug the cable into the port on the motherboard instead of the controller.

If you are purchasing an add-on controller card, you will need to install the controller in one of the empty slots in your computer. Remove the screw holding the metal plate in place and insert the controller into the PCI, EISA or ISA slot on the motherboard, making sure the metal plate from the controller fits into the grooves on the computer frame. Replace the screw and connect the SCSI cables to the controller and then the hard drive. If you have any questions, refer to the installation manual enclosed with your controller.

**Backup and restore**

One of the most common methods of backup is tape backup. Tape drives are available from IBM and other major manufacturers. This method is preferred for overnight backups that run while your business is closed or while you sleep.

Another method of backup is the removable drive. There are several brands of removable drives. IOMEGA is one of the better-known manufacturers. IOMEGA manufactures the popular ZIP drive and the JAZ drive. These drives can be used for backup and hooked up or removed with little trouble.

## **Utilities**

Your Ultrastar drive comes low-level formatted and free of defects. *Note: Do not attempt to low-level format your drive.* If data must be removed from the drive, there are 2 utilities available on the IBM Hard Disk Drive Technical Support Center FTP site at: <http://index.storsys.ibm.com/hddtech>

### **ZAP**

Zap is a utility that will 'zap' your boot sector by writing 0's to the first 128 sectors of your drive.

### **WIPE**

Wipe performs the function of ZAP and also writes 0's to the entire drive.

These utilities should be sufficient to return your drive to factory-shipped condition.

## **Drive copy**

If you are replacing an existing hard drive with the Ultrastar drive, you may want to copy all your files from the existing drive to the Ultrastar. There are several software programs available that copy one drive to another.

### **PowerQuest Drive Copy 2.0**

**(<http://www.powerquest.com/product/dc.index.html>)**

This utility supports all operating systems, has mouse support, selective partitioning, selective sector copying, and automatically creates new DOS reboot disk. This utility is not limited by drive size.

### **QuarterDeck Systems DiskClone**

**(<http://www.qdeck.com/qdeck/products/diskclone/indexreg.html>)**

This utility supports all operating systems and has mouse support.

### **ITS Systems EZ-Upgrader**

**(<http://www.itechs-systems.com/>)**

This utility can be used with Windows® 3.1 and Windows® 95 operating systems.

### **Image Systems Solutions Drive-to-Drive**

**(<http://www.img-systems.com/d2ddesc.htm>)**

This utility is for use with all operating systems, but is limited to copying drives with similar physical geometry.

### **FWB software Drive Up!**

**(<http://www.fwb.com/>)**

This utility is used with Windows® operating systems only.

## *IBM storage products*

### **Compatibility matrix**

The IBM SIT Lab thoroughly tests Ultrastar drives for compatibility with a wide variety of systems, controller cards, operating systems, and BIOS versions. Testing was done to demonstrate compatibility with the following hardware and software. Other combinations of hardware and software may function with this drive, but were not tested.

#### **Systems**

Acer AP53A  
Apple Performa 6400/180  
ASUS P2B-IS  
Compaq Deskpro 6000  
Compaq Professional Workstation 6000  
Compaq Proliant 1500  
Data General  
Dell Dimension XPS D300  
Dell OptiPlex Gxa 266MTbr  
Dell Power Edge 4100  
Digital Alpha Server 800 5/333  
Digital Alpha Server 4100  
Gateway 2000 P6-200  
Gateway G6-200  
HP Netserver LXPro  
HP Kayak GM  
IBM Intellistation Z-Pro  
Micron ClientPro XLU  
Micron Millenia MME  
Micron Powerdign XSU  
NEC Direction SPL 266  
NEC Powermate Enterprise  
SNI Primergy 460  
Silicone Graphics Octane  
SGI 02  
SGI Octane  
Sun Sparc Station 20  
Tyan P5-166 Motherboard

#### **SCSI controllers**

Adaptec ARO Additional Storage  
Adaptec 2940UW  
Adaptec 2940U2W  
Adaptec 3940W  
Adaptec 3950U2B  
Adaptec 7880  
Adaptec AHA-7890  
Adaptec AIC-7880  
Adaptec Power Domain AHA-3940UW v3  
Buslogic BT-956  
Compaq Wide-Ultra SCSI-2  
Compaq Wide-Ultra SCSI-3  
DG Proprietary  
Diamond Fireport 40  
DPT 2144UW  
DPT 3334UW  
EMC 80 Pin Ultra  
Integral V.QL104B

Mylex DAC 960  
Qlogic  
Qlogic QLA1040B  
Sun  
Symbios Logic

#### **Operating systems**

Irix 6.3  
Irix 6.4 Rel 6.5  
Mac System 7.5.3  
Mac System 7.6  
Mac System 8.5  
MS DOS 6.20  
OS2/Warp V.4.20  
Phoenix  
SCO 5.0.2  
SCO Unix 3.2.4.2  
SCO Unix 5.0.2  
SCO Unixware 2.1.1  
SCO Unixware 2.1.2  
SCO Unixware 5.0.2  
Sun OS 5.5.1  
Sun Solaris/Unix  
Unix  
Windows 95  
Windows 95 OSR2  
Windows 98  
Windows NT 4.0, Build 1381  
Windows NT 4.0

#### **BIOSs**

AlphaBios 5.64 971212.1414  
AMI 1.00.02.DT05  
AMI 1.00.11.CD0L  
AMI 1.00.04.CS1T  
AMI 1.00.08.CSIT  
Award 4.51PG  
Compaq 686V 9/28/97  
Compaq 586M 11/18/97  
Compaq 5/5/97  
Compaq E12 4/5/96  
Galaxy  
IBM Sure Path 1/24/97  
Phoenix 1.10 A04  
Phoenix 4.0, Release 5.12  
Phoenix 4.0, Release 6  
Phoenix 4.05 1.01.92  
Phoenix 4.05 A06  
SGI 6.4 2/5/97

## *IBM storage products*

### **Technical support**

Before calling technical support make sure you have your drive part number, serial number, and system information.

Contact technical support via:

**Web** [www.ibm.com/harddrive](http://www.ibm.com/harddrive)

**Voice** 888.426.5214 or 507.286.5825

**Fax** 507.253.4111

**e-mail** [drive@us.ibm.com](mailto:drive@us.ibm.com)

Support is also available in Singapore at:

**Voice** 1800.418.9595 or (65) 65.6418.9595

**e-mail** [drive@sg.ibm.com](mailto:drive@sg.ibm.com)

### ***Automated Fax Back Service***

U.S.A. 408.256.5218

Singapore 800.418.9696

England 0800.96.6948

Germany 0130.82.6089

France 0800.902229

Italy 167.875148

## **Glossary**

---

### **ANSI** (American National Standards Institute)

ANSI is the lead organization for encouraging and developing technological standards. ANSI represents the United States in the IEC (International Electrotechnical Commission) and the ISO (International Standards Organization).

### **Backup**

Storing information from a hard drive to another storage area in order to prevent data loss. Tape drives and Zip drives (IOMEGA) are two common mediums for saving vital information contained on a hard drive.

### **BIOS** (Basic Input/Output System)

The BIOS is the first level of software contained in a computer. It provides basic, low level control for keyboards, video, hard disk drives, and floppy drives. It also provides the initial intelligence that allows the computer system to find an operating system to run.

### **Boot/Boot-up**

To prepare a computer for operation by loading an operating system.

### **Capacity**

The amount of information, expressed in bytes, that can be stored on a hard drive. Also known as *storage capacity*.

### **Compatibility**

The capability of a hardware or software component to conform with the interface requirements of a given data processing system without adversely affecting its functions.

### **Cylinder**

1) In an assembly of magnetic disks, the set of all tracks that can be accessed by all the magnetic heads of a comb in a given position. 2) The tracks of a disk storage device that can be accessed without repositioning the access mechanism.

### **Disk drive**

The primary data storage device used by computers. Disk drives are used to record, store and retrieve digital information.

### **Electrostatic discharge**

The rapid change in electrical energy caused by static electricity. This can damage or destroy electronic equipment or hardware. Electrostatic discharge can be prevented by grounding oneself before handling any electronic equipment.

### **FAT16/FAT32** (File Allocation Table)

The file allocation table is a group of sectors in a hard drive that contains address chains for the different files on a hard disk drive. There are usually two FATs (kept in different locations) on a hard drive. FAT32 is available in the Windows® 95 & Windows® 98 operating systems. FAT32 receives its designation because it allows 32 bits of addressing as opposed to 16 bits in the FAT16 file system.

### **FDISK**

FDISK is a program run in DOS that allows a user to partition a hard disk drive. Partitioning your hard disk drive is essential for it to work properly.

## *IBM storage products*

### **Format**

To prepare a hard drive so that it can store data. In the DOS formatting process, the computer verifies the clusters within a partition.

### **FTP (File Transfer Protocol)**

In the Internet suite of protocols, an application layer protocol that uses TCP and Telnet services to transfer bulk-data files between machines or hosts.

### **Hard disk drive (HDD)**

A stand alone disk drive that reads and writes data onto rigid disks and can be attached to a port on the system unit. Synonymous with *fixed disk drive* and *hard drive*.

### **Head**

The tiny electromagnetic coil and metal pole used to create and read back magnetic patterns on the disk.

### **HPFS (High Performance File System)**

The file system used by the OS/2 operating system.

### **Interface**

A hardware or software protocol, contained in the electronics of the disk controller and drive, that manages the exchange of data between the hard disk drive and the computer. The most common interfaces for small computer systems are ATA (IDE) and SCSI.

### **Jumpers**

Small pieces of plastic with a conductive center used to connect pins on a device.

### **Jumper settings**

Different modes which are achieved by placing the jumper on particular pins on a device. These modes determine the behavior of the device. Settings are changeable by the user, but remain constant during operation. See *Jumpers*.

### **LVD (Low Voltage Differential)**

A highly compatible computer disk drive interface that is faster and more reliable than SCSI. Also known as *Ultra2SCSI*.

### **Motherboard**

Holds the computer's main processors and circuitry, and also contains the memory, BIOS, interconnection circuitry and expansion slots.

### **Multi-mode**

A drive that can operate on an LVD bus or a Single-ended bus.

### **NTFS (NT File System)**

An advanced file system used by the Windows NT operating system.

### **Operating system**

Software that controls the execution of programs and may provide functions such as resource allocation, scheduling, input/output control, and data management. Although operating systems are predominantly software, partial hardware implementations are possible.

### **OS/2**

A fully preemptive, multitasking operating system developed by IBM. OS/2 also supports HPFS.

**Partition**

A portion of a hard drive dedicated to a particular operating system or application and accessed as a single logical volume.

**SCSI** (Small Computer System Interface)

Pronounced “scuzzy”. An intelligent parallel peripheral interface characterized by its use of high level communication between devices.

**Sector**

On a hard drive, the minimum segment of track length that the hard disk drive can assign to store information.

**Termination**

The signals on a SCSI bus must be terminated at both ends of the bus. This is generally done automatically by the controller and requires an “external” terminator on the last connector of the bus.

**Track**

One of the many concentric magnetic circle patterns written on a disk surface as a guide for storing and reading data.

**Wipe**

Wipe is a software utility that writes zeros to every sector on a hard disk drive up to 8 GB. See *Zap*.

**Windows® NT**

Microsoft’s 32-bit server operating system.

**Windows® 98**

Microsoft operating system.

**Zap**

A utility in which the first 128 sectors of a hard drive are overwritten with zeros. See *Wipe*.

**Zip drive**

A drive which uses increased real density on floppy disk technology to increase storage capacity. Zip diskettes have a storage capacity of 100 MB.



© International Business Machines Corporation 1999

[www.ibm.com/harddrive](http://www.ibm.com/harddrive)

**IBM Hard Disk Drive Technical Support Center**

Dept. D8M  
3605 Highway 52 North  
Rochester, MN 55901  
Telephone: 888.IBM.5214 or 507.286.5825  
Fax: 507.253.DRIVE  
E-mail: [drive@us.ibm.com](mailto:drive@us.ibm.com)

**Singapore Technical Support Center**

Telephone: 1800.418.9595 or 65.6.418.9595  
E-mail: [drive@sg.ibm.com](mailto:drive@sg.ibm.com)

**IBM Storage Systems Division**

5600 Cottle Road  
San Jose, CA 95193  
[www.ibm.com/storage](http://www.ibm.com/storage)

Asia-Pacific Headquarters: 65.320.1234

European Headquarters: 44.01.705.561.871

Japan Sales Branch Office: 81.46645.1039

Printed in the United States of America  
02-99  
All Rights Reserved

IBM is the registered trademark of International Business Machines Corporation.

Other company, product, and service names may be trademarks or service marks of others.

Produced by the IBM Hard Disk Drive Technical Support Center.

IBM products use industry standard interfaces and are generally compatible with standard Systems, System Boards, SCSI Controllers, Operating Systems, and BIOS. This is not meant to be a complete list of compatible products. This information is believed to be accurate, but is supplied without guarantee.

Document subject to change without notice.

Date: 18th February, 1999