

DK32EJ-FC

Product Specifications

Read and follow all instructions and cautions for safety described in this document before using the drive.

It is recommended that this manual is kept at a proper location for quick reference.

Hitachi, Ltd.
Data Storage Systems Division

All Rights Reserved, Copyright © 2002, Hitachi, Ltd.

Drawing No.	Sheet No.	Revision	2
K6602762	1/38	2002/7/1	

REVISION CONTROL

Remarks

AD: Addition , CH: Change ,CR: Correction ,DL: Deletion

Rev.	Date	Signature	Page	Description	Remarks
0	2002/2/25	DWN: Y.Hori CHKD: I.Kobayashi APPD: K.Tsuneta	All	First Issuance	
1	2002/4/1	DWN: Y.Hori CHKD: I.Kobayashi APPD: K.Tsuneta	12	Environmental conditions (Atmosphere)	CH
			15	Power measurement (Operating)	AD
			29	Packing	CH
			35	-Parallel ESI and SEL0-6	CR
2	2002/7/1	DWN: Y.Hori CHKD: I.Kobayashi APPD: K.Tsuneta	10	ANSI specifications	CR
			12, 14	Environmental conditions (Non-operating shock)	CH
			35	Table 12.4	CR

Drawing No.	Sheet No.	Revision	2
K6602762	2/38	2002/7/1	

TABLE OF CONTENTS

Chapter	Page
1 Before Using the Drive ( To use this product safely).....	5
2 Features	8
3 Standards and Related Documents.....	9
4 Description	11
4.1 Characteristics.....	11
4.2 Environmental conditions and reliability.....	12
5 DC power Interface.....	15
5.1 DC Power Requirement.....	15
5.2 Power Supply Current	16
5.3 Spindle Start and Stop.....	16
6 Connecting Methods.....	18
7 Interface.....	19
7.1 Summary of SCSI Controller	19
7.2 Summary of SCSI Commands.....	21
7.3 Summary of FC-AL.....	23
8 Mounting and Handling	25
8.1 Orientations	25
8.2 Mounting of the drive	26
8.3 Mounting dimensions	27
8.4 Precautions on the off-line test or bench test.....	28
8.5 Cooling of the drive.....	28
8.6 Reliability temperature	28
9 Precautions for handling.....	29
9.1 Packing.....	29
9.2 Transportation.....	29
9.3 Storage.....	29
9.4 Other Precautions	29
10 Maintenance.....	30
11 Physical interface.....	31
11.1 Connector Specifications	31
11.2 Port Bypass Circuit.....	31
11.3 Connector Layout.....	32

Drawing No.	Sheet No.	Revision	2
K6602762	3/38	2002/7/1	

12	Pin assignment.....	33
12.1	SCSI signal connector.....	33
12.2	Other connectors.....	34
12.3	Device control code.....	35
12.4	Enable Port Bypass.....	35
12.5	-Parallel ESI and SEL0-6.....	35
13	Jumper Socket setting.....	36
13.1	Jumper connector layout.....	36
13.2	Jumper socket setting	37
13.3	Jumper socket part number.....	38

Drawing No.	Sheet No.	Revision	2
K6602762	4/38	2002/7/1	

1 Before Using the Drive

Read and follow all instructions and cautions described in this chapter before using the drive.

It is recommended that this manual is kept at a proper location for quick reference. The description related to safety in this chapter may be changed without notice.

Influence for environment

Although this product emits electro-magnetic field, it will be found to be in compliance with the EMI regulations such as VCCI class B, FCC Part 15 class B. However, anything other than this product, such as an interface cable, is excluded. Therefore, the following cases require a system side improvement.

- (1) Disturbance of operations of other products or equipment
- (2) Disturbance caused by other product, such as cabling, to operations of other products or equipment.

Do not change the condition of the drive, excluding the change admitted by Hitachi. Violating above-mentioned precautions will void any warranties of the HDD.



To use this product safely

Please read and understand the following explanation for safety.

1.1 Cautions related to safety

- 1.1.1 When handling the drive, follow all instructions and cautions described in this manual and the packing specification manual.
- 1.1.2 The safety instructions in this manual are thoroughly considered, but unexpected situations can occur. Not only follow the instructions in this manual, but also be careful for the safety by yourself.
- 1.1.3 Do not convert or change the drive. Convert or change of the drive will void any warranties.
- 1.1.4 It is customer's responsibility to assure the actual system in which the drive is installed meets the appropriate safety regulation. However the drive itself is found to be compliance with the following standards:

UL 1950 3rd Edition
CAN/CSA C22.2-M95
IEC60950: 1991
EN60950: 1992
FCC Part15 Class B, VCCI Class B
EN55022: 1998, Class B (CE Mark)
AS/NZS 3548: 1995, Class B (C-tick)
CNS13438/C6357, Class B (BSMI)

Drawing No.	Sheet No.	Revision	2
K6602762	5/38	2002/7/1	

Symbol of safety caution

Safety instructions and cautions are indicated as the following head line which means as follows.



This symbol indicates that potential danger may exist which may cause slight or medium grade bodily injury if safety instructions are not followed.

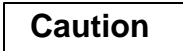

This symbol indicates that potential danger may exist which may cause damage to the product or to the neighboring property if safety instructions are not followed..

1.2 Cautions related to safety

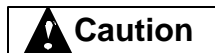

- 1.2.1 This product is not authorized for use in life support devices or other applications which pose a significant risk of personal injury.
- 1.2.2 Handle the drive with care not to suffer bodily injury caused by hitting the edge of the frame or accidental dropping of the drive.
- 1.2.3 Since the drive uses glass media for the disk platter, opening of HDA may cause bodily injury. Warranty void in case of opened HDA or any broken HDA seals. Do not open the HDA or break any HDA seals.
- 1.2.4 Temperature of the drive may become more than 50°C. Handle the drive carefully not to get burned.

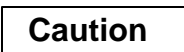

- 1.2.5 To prevent data from being lost due to an unexpected fatal error, data back up is required.
- 1.2.6 If a foreign conductive substance (metallic powder, fluid, etc.) adheres to active metal of the drive (Print pattern, component lead, etc. on Printed Circuit Board (PCB)), it may cause catastrophic failures. Customer should protect the drive from the above condition.
- 1.2.7 Improper insertion of connector or wrong jumper setting may cause catastrophic failures. Referring to this manual prior to the connector insertion or jumper setting can help insure correct insertion.
- 1.2.8 Follow the environmental conditions and power requirement described in this manual. If violating these specifications, the drive failure may occur.

Drawing No.	Sheet No.	Revision	2
K6602762	6/38	2002/7/1	

Caution

- 1.2.9 Protect the drive against Electro Static Discharge (ESD) during handling.
- 1.2.10 If storage period becomes long after unpacking, supply power to the drive and rotate the disks approximately 10 minutes. This operation shall be executed every 3 months.
- 1.2.11 Protect the drive against shocks with the corrugated board and cushioning material provided by the manufacturer, or with Hitachi Approved containers.
- 1.2.12 When mounting the drive, use the size of screws and the torque recommended in this manual. If non-recommended size of screws and torque are used, it may cause catastrophic failures.
- 1.2.13 Do not press top cover and bottom PCB of the drive. It may cause catastrophic failures.
- 1.2.14 Read and follow all instructions and cautions described on the top cover of the drive, and in the chapter, Precautions for handling, in this manual.
- 1.2.15 In case of fluctuations in the DC power (spikes, momentary shut off, etc.), the data being recorded or to be recorded from buffer memory are not assured.
- 1.2.16 Do not cover the breathing hole on the surface of the drive with use of a seal.

Warranty and Limited Liability

This product is sold with a limited warranty and specific remedies are available to the original purchaser in the event the product fails to conform to the limited warranty. Hitachi's liability may be further limited in accordance with its sales contact.

In general, Hitachi shall not be responsible for product damages caused by natural disasters, fire, static discharge, misuse, abuse, neglect, improper handling or installation, unauthorized repair, alteration, or accident. In no event will Hitachi be liable for loss of data stored on product.

Hitachi shall not be liable for any special, incidental or consequential damages, even if informed of the possibility thereof in advance.

Please see your sales contact for a complete statement of warranty rights, remedies and limitation of liability.

Drawing No.	Sheet No.	Revision	2
K6602762	7/38	2002/7/1	

2 Features

The DK32EJ series uses high performance sputtered disks, GMR heads, and a rotary type voice coil motor to drive the heads. These features provide high capacity, high speed positioning and high reliability.

The DK32EJ-FC uses a SCSI interface as the upper level layer though the physical host interface is changed to Fibre Channel. Therefore, the host can access the FC disk drive with almost same manner as the SCSI disk drive. Some functions dependent on physical interface is different from that of SCSI disk drives.

FC-AL Interface specifications for the DK32EJ are found in the companion manual:
" Hitachi 3.5 inch Magnetic Disk Drive Reference Manual for DK32EJ
(Fibre Channel Interface Specification) ".

Table 2.1 Models

Model	Interface type	Storage capacity (Formatted)
DK32EJ-14FC	SCA-2 Fibre Channel (40pin)	147.8GB
DK32EJ-72FC	SCA-2 Fibre Channel (40pin)	73.9GB
DK32EJ-36FC	SCA-2 Fibre Channel (40pin)	36.9GB

Note 1: This document may be changed without notice.

Drawing No.	Sheet No.	Revision	2
K6602762	8/38	2002/7/1	

3 Standards and Related Documents

(a) Safety standards

It is the user's responsibility to assure the actual system in which the drive is installed meets the appropriate safety requirements. However, the drive was tested to be in compliance with the following standards:

UL 1950 3rd Edition
CAN/ CSA C22.2 - M95
IEC60950: 1991
EN60950: 1992

(b) Regulations related to electro-magnetic compatibility

It is the user's responsibility to assure the actual system in which the drive is installed meets the appropriate EMI requirements. However the drive has been tested using proper shielding and grounding, and found to be in compliance with the following regulations:

FCC Part 15, class B
VCCI class B
EN55022 class B
BSMI
C-Tick

(c) Related Documents

- (1) Hitachi 3.5 inch Magnetic Disk Drive Reference Manual for DK32EJ
(Fibre Channel Interface Specification)
K6602771
- (2) Packing Specification
K6601289
- (3) DK32EJ-14FC Design Verification Test Reports
K6602763
- (3) DK32EJ-72FC Design Verification Test Reports
K6602764
- (4) DK32EJ-36FC Design Verification Test Reports
K6602765

Drawing No.	Sheet No.	Revision	2
K6602762	9/38	2002/7/1	

The specifications related to Fibre Channel are as follows.

- (1) Fibre Channel Protocol for SCSI (FCP) X3.269-199X Revision 012
- (2) Fibre Channel Arbitrated Loop (FC-AL) X3T11/Project 960D/Rev 4.5
- (3) Fibre Channel Arbitrated Loop (FC-AL-2) X3T11/Project 1133D/Rev 7.0
- (4) Fibre Channel Private Loop SCSI Direct Attach (FC-PLDA)
X3T11/Project 1162DT/Rev 2.1
- (5) Fibre Channel Fabric Loop Attachment (FC-FLA)
X3T11/Project 1235DT/Rev 2.7
- (6) Fibre Channel Physical and Signaling Interface (FC-PH)
X3T11/Project 755D/Rev 4.3
- (7) Fibre Channel Physical and Signaling Interface-2 (FC-PH-2)
X3T11/Project 960D/ Rev 7.4
- (8) Fibre Channel Physical and Signaling Interface-3 (FC-PH-3)
X3T11/Project 1119D/ Rev 9.4
- (9) Small Computer Systems Interface-2 (SCSI-2) X3.301-1997
- (10) SCSI-3 Primary Commands (SPC) X3T10/Project 955D/Rev 11a
- (11) SCSI-3 Block Commands (SBC) X3T10/Project 996D/Rev 8c
- (12) SCSI-3 Primary Commands-2 (SPC-2) X3T10/Project 1236D/Rev 20
- (13) SCSI-3 Primary Commands-3 (SPC-3) X3T10/Project 1416D/Rev 5
- (14) SCSI-3 Controller Commands (SCC) X3T10/Project 1047D/Rev 6c
- (15) SFF-8045 Specification for 40-pin SCA-2 Connector w/Parallel Section Rev 4.5
- (16) SFF-8067 Specification for 40-pin SCA-2 Connector w/Bidirectional ESI Rev 2.8
- (17) SCSI-3 Enclosure Service Command set (SES) X3T10/Project 1212D/Rev 8b
- (18) Fibre Channel Physical Interfaces (FC-PI) NCITS/Project 1235D/ Rev 8.0

Drawing No.	Sheet No.	Revision	2
K6602762	10/38	2002/7/1	

4 Description

4.1 Characteristics

Table 4.1 Characteristics

Item		Specifications						unit	
		DK32EJ-14 FC		DK32EJ-72 FC		DK32EJ-36 FC			
Configuration	Storage capacity (formatted) (see Note 1,2,13)	147.8		73.9		36.9		GB	
	Bytes/sector (see Note 3)	512, 516, 520, 524, 528,1024						Bytes	
	Number of disks	5		3		2			
	Number of heads	10		5		3			
	Areal density	30.0		30.0		30.0		Gb/inch ²	
	Recording method	MEEPRML							
Performance	Seek time read / write (see Note 5)	average	4.9 / 5.4						ms
		full stroke	10 / 11						ms
		1 track	0.5 / 0.7						ms
	Average latency	2.99						ms	
	Rotational speed	10025						rpm	
	Data transfer rate (In drive)	458 - 799		458 - 799		458 - 799		Mb/s	
	Start time (see Note 5)	25		25		25		s	
	Data transfer rate (Controller) (see Note 4)	SCA-2 Fibre Channel		200 max.				MB/s	
	Buffer size	4M						Bytes	
	Power requirement		Typ. (Note5)	3sigma	Typ. (Note5)	3sigma	Typ. (Note 5)	3sigma	
		12V Spin-up, peak	2.15	2.26	2.15	2.26	2.15	2.26	A
		12V Seek, peak	2.46	2.52	2.30	2.42	2.20	2.33	A
		12V Idle, ave.	0.65	0.80	0.50	0.64	0.40	0.54	A
5V R/W, peak		1.83	1.92	1.83	1.92	1.83	1.92	A	
5V Read, ave.		1.63	1.72	1.63	1.72	1.63	1.72	A	
5V Write, ave.		1.61	1.70	1.61	1.70	1.61	1.70	A	
5V Idle, ave.	1.18	1.23	1.18	1.23	1.18	1.23	A		
Physical dimensions	length x width x height	146.0x101.6x25.4						mm	
	weight	0.75		0.73		0.71		kg	
Power dissipation	+12V Idle / +5V Idle, (Average)	13.7		11.9		10.7		W	
Energy consumption rate (see Note 12)		0.093		0.16		0.29			

Drawing No.	Sheet No.	Revision	2
K6602762	11/38	2002/7/1	

4.2 Environmental conditions and reliability

Table 4.2 Environmental conditions and reliability

Item			DK32EJ-14	DK32EJ-72, 36
Environmental conditions	Temperature	operating	5 to 55°C	
		non-operating	-40 to 70°C	
		storage/shipping	-40 to 70°C	
	Temperature gradient		20°C per hour maximum	
	Humidity	operating	5 to 90%RH	
		non-operating	5 to 90%RH	
	Wet bulb temperature		29°C maximum (non condensing)	
	Atmosphere		No corrosive gas, saline atmosphere or organic-metal compound (Example. organic silicon, organic tin)	
	Altitude	operating	-300 to 3,000 m	
non-operating		-300 to 12,000 m		
Magnetic field		400 micro Tesla maximum		
Shock and vibration	Vibration (see Note 6)	operating	9.8 m/s ² (1.0G) maximum	
		non-operating	49 m/s ² (5.0G) maximum	
	Shock (see Note 7)	operating	147 m/s ² (15G) maximum [11ms]	
		non-operating	735 m/s ² (75G) maximum [11ms]	
			1960 m/s ² (200G) maximum [2ms]	2450 m/s ² (250G) maximum [2ms]
Acoustic noise	Acoustic noise (see Note 8)		3.9 bel average	
Reliability (see Note 10)	Data Reliability (see Note 9)		Recoverable error: 10 error in 10 ¹² bits read Non-recoverable error: 1 error in 10 ¹⁴ bits read	
	Seek error rate (see Note 9)		10 errors in 10 ⁸ seeks	
	Life		5 years (Surface temperature of HDA is 45°C or less) Life of the drive does not change in the case that the drive is used intermittently. (See section 8.6)	
	MTBF (see Note 11)		Expected 1,200,000 hours	

Drawing No.	Sheet No.	Revision	2
K6602762	12/38	2002/7/1	

- Note 1. Storage capacity does not include spare sector and spare cylinder.
- Note 2. This is the value in the case that the drive is formatted to 512 Bytes/sector.
(1 gigabyte shows 1×10^9 bytes on this document.)
- Note 3. DK32EJ is formatted to 512 Bytes/sector as the default.
If non-512 Bytes/sector is required, customer can change it by re-format of the drive.
- Note 4. Data transfer rate is degraded with cable or host condition or electrical noise.
- Note 5. These specifications are typical under the following conditions:
1. Voltage is 5.0V/12.0V as measured on the edge of drive connector.
 2. Surface temperature of HDA is 35°C.

If SCSI commands are issued during start-up (like TEST UNIT READY or REQUEST SENSE) in less than 10 ms intervals, then the start-up time may be extended.

- Note 6. The disk drive orientation for vibration test is shown below.

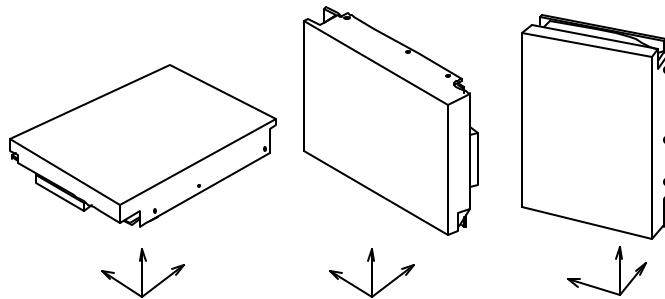

Figure 4.1 Vibration test direction

Test conditions on vibration test are as follows.

(1) Operating

Acceleration frequency : 5 to 400 Hz,

Acceleration level : 9.8 m/s^2 (1.0G)

Sweep rate : 0.5 octave / minute

Test cycle : 1 turn

(2) Non-operating

Acceleration frequency: 5 to 22 Hz, Maximum displacement: 2.56mm

Acceleration frequency: 22 to 400 Hz, Acceleration level: 49 m/s^2 (5.0G)

Sweep rate: 0.5 octave / minute

Test cycle: 1 turn

Drawing No.	Sheet No.	Revision	2
K6602762	13/38	2002/7/1	

Note 7. The disk drive orientation for shock test is shown in Figure 4.2.

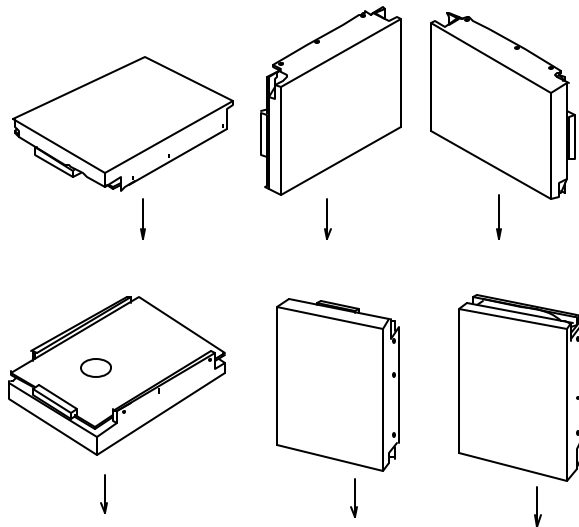

Figure 4.2 Shock test direction

Test conditions on shock test are as follows.

(1) Operating

147m/s²(15G) (Shock mode: half sine wave 11 ms, Test cycle: 5 times)

(2) Non-operating

735m/s²(75G) (Shock mode: half sine wave 11 ms, Test cycle: 5 times)

In case of DK32EJ-14FC,

1960m/s²(200G) (Shock mode: half sine wave 2 ms, Test cycle: 5 times)

In case of DK32EJ-72FC, -36FC,

2450m/s²(250G) (Shock mode: half sine wave 2 ms, Test cycle: 5 times)

Note 8. Acoustic noise is measured except for the start, stop and seek operations.

Note 9. Recoverable error is measured at the nominal condition with voltage, temperature and default error recovery parameters.

Note 10. The drive should be mounted properly (see section 8).

Note 11. MTBF represents a prediction of performance based upon a large statistical sample calculated in accordance with Hitachi's standard procedures.

Hitachi does not warrant that the predicted MTBF is representative of any particular unit or group of units comprising a customer base. The actual failure rates will vary from unit to unit. Surface temperature of HDA is 50°C or less.

A failure defined by MTBF calculation is any event that requires repair or replacement of HDD.

Drawing No.	Sheet No.	Revision	2
K6602762	14/38	2002/7/1	

Note 12. Total idle mode power (W) / Total formatted capacity (GB)

Note 13. When the DK32EJ-14 is formatted to 512 Bytes/sector,
the maximum Logical Block Address is (113711FF)h.
When the DK32EJ-72 is formatted to 512 Bytes/sector,
the maximum Logical Block Address is (89B88FF)h.
When the DK32EJ-36 is formatted to 512 Bytes/sector,
the maximum Logical Block Address is (44DC47F)h.

Note 14. Power measurement values in operating (Random Seek/ Read/ Write) case are shown in Table 4.3.

Table 4.3 Power measurement (Operating) Unit:(W)

	DK32EJ-14FC	DK32EJ-72FC	DK32EJ-36FC
30 IOs per second	14.5	12.6	11.4
60 IOs per second	15.3	13.4	12.2
90 IOs per second	16.1	14.2	13.0

5 DC power Interface

5.1 DC Power Requirement

The drives are operated on DC power (+5V, +12V) only.

No power sequencing is required.

The +5 and +12 Volts can be applied in any order.

Table 5.1 DC Power Requirement

Power supply	Voltage tolerance	Allowed ripple and noise
+5V DC	5.0V +/-5%	Less than 150mVp-p (0 - 100kHz) Less than 100mVp-p (100kHz - 10MHz)
+12V DC	12.0V +/-5%	Less than 150mVp-p (0 - 100kHz) Less than 100mVp-p (100kHz - 10MHz)

Note 1. Voltage tolerance is measured at the SCA-2 connector on the PCB.

The ripple current occurs during the motor start-up and seek.

Note 2. In case of fluctuations in the DC power (spikes, momentary shut off, etc.), the data being recorded or to be recorded from buffer memory are not assured.

Drawing No.	Sheet No.	Revision	2
K6602762	15/38	2002/7/1	

5.2 Power supply current

+12V Current
[A]

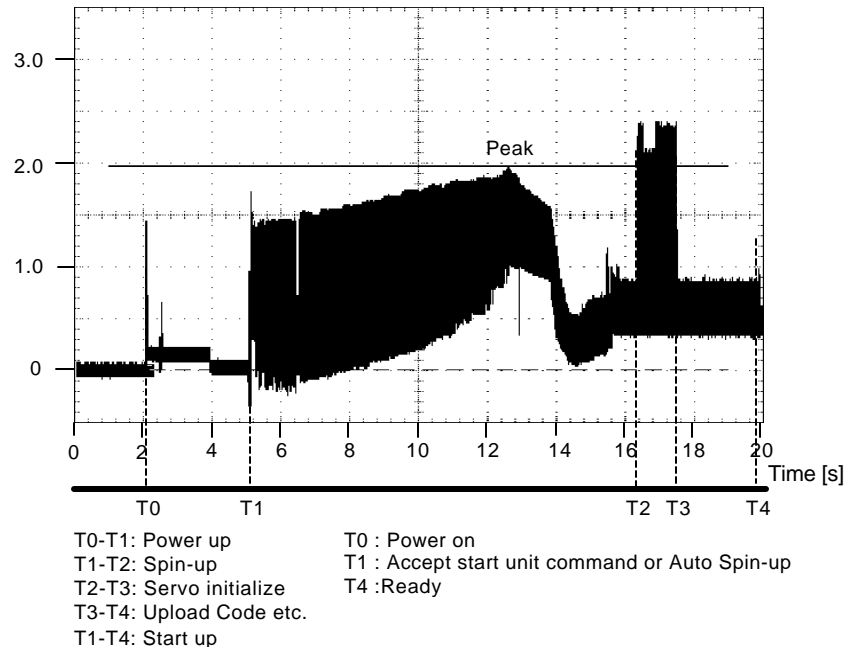

Fig 5.1 Current transition for +12V

Note: A retry Spin-up operation may be attempted during the Start up process.

5.3 Spindle Start and Stop

5.3.1 Start and Stop Time

Table 5.2 Start and Stop time

Item	Typical		unit
Start	25	Note 1	s
Stop	25	Note 2	s

Note 1. Start time means that the time of becoming ready, after DC power has been applied in the case of Enable Auto Start mode, or after Start Unit command (immed=0) has accepted in other case. If internal retry is executed during the Start-up operation, the Start time may exceed typical value. It is recommended to have 60 seconds for the Start time. In the case of a spindle start-up failure, the time of an internal retry operation is 130 seconds maximum.

Caution

Note 2. Beginning of stop time is basically decided by +12V DC power off. In case of +5V DC power off only, stop time is 65 seconds (typ). Do not move the drive until motor stop completely. Stop time means that the time to stop the spindle rotation, after DC power has been shut off, or after stop operation has started.

Drawing No.	Sheet No.	Revision	2
K6602762	16/38	2002/7/1	

5.3.2 Spindle Start Selection

The mode of starting the driver's motor is determined by the signals START1 and START2 in SCSI bus connector (C1), as shown in table 5.3.

Table 5.3 Spindle Start Selection

START1	START2	Motor Spin Function
HIGH	HIGH	(Drive is not mated.)
LOW	HIGH	Command Start mode
HIGH	LOW	Delayed Start mode
LOW	LOW	Auto Start mode

When multiple disk drives are connected to the same power supply and turned on simultaneously, a large current will be required at power up. In the above case, it is recommended to turn the motors on one by one at intervals in order to minimize 12V line current.

This can be done according to the following 3 methods:

1. If Command Start mode is set;
 - (1) Use a spindle start command for each drive, issuing it to the next drive after receiving the previous drive's Ready condition.
 - or
 - (2) Use the spindle start command for each drive, issuing it at intervals of more than 10 seconds.
2. If Delayed Start mode is set;

Upon power on condition, the drives will automatically spin up in 10 second intervals according to their Arbitrated Loop Physical Address (AL_PA). (The drive with the lowest AL_PA will start first.) In the case that their AL_PA are more than 7, the drives will automatically spin up in 10 second intervals according to the modulo 8 value of numeric AL_PA of the drive.
3. If Auto Start mode is set;

Manually power on drives at intervals of more than 10 seconds.

Drawing No.	Sheet No.	Revision	2
K6602762	17/38	2002/7/1	

6 Connecting Methods

6.1 Interface Cable (FC-AL)

Fibre Channel drives may be connected in a loop together or with other compatible FC-AL devices. A maximum of 126 addresses are available for FC-AL devices.

The FC-AL drive has two independent ports and can be connected to two independent loops. Above-mentioned two ports can not be connected to same loop. The loop constructions that the DK32EJ-FC supports are shown in figure 6.1 and 6.2.

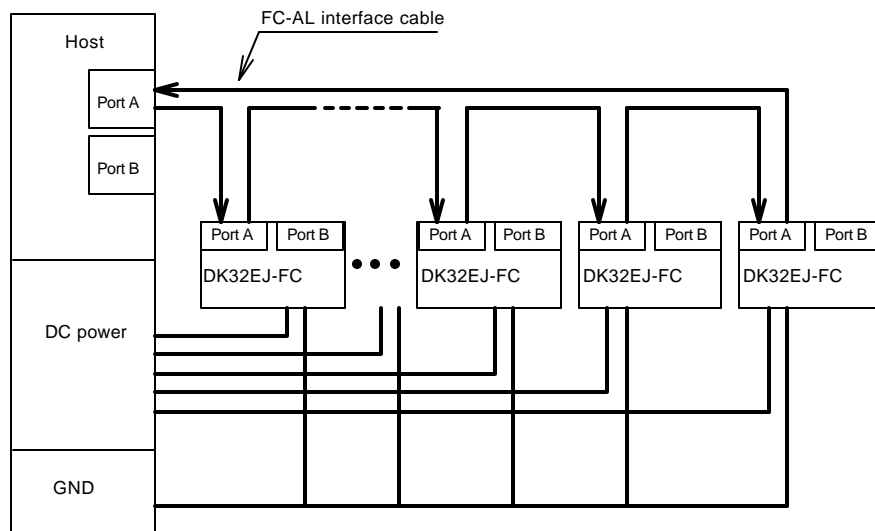

Figure 6.1 Cabling layout (Single Loop)

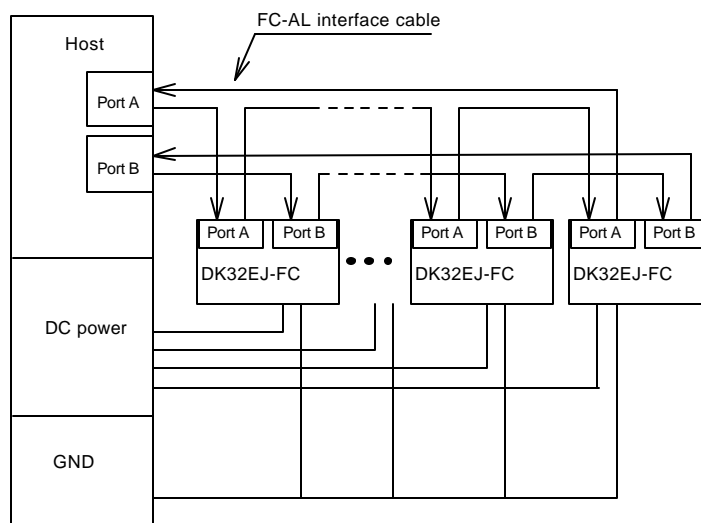

Figure 6.2 Cabling layout (Dual Loop)

Drawing No.	Sheet No.	Revision	2
K6602762	18/38	2002/7/1	

7 Interface

7.1 Summary of SCSI Controller

The DK32EJ SCSI controller interfaces between the drive and the host computer with the Small Computer System Interface (SCSI).

(1) ANSI standard

The controller supports the SCSI interface that conforms to the ANSI specifications shown in chapter 3.

(2) Compact design

The controller is embedded within the disk drive.

(3) FIFO buffer

The SCSI controller has 4M bytes of FIFO buffer. This data buffering feature prevents the SCSI controller from delay during the reconnect process and reduces the latency time that is generated by the difference of the data transfer rate between media and host.

(4) Automatic error retry

The controller automatically retries whenever the disk drive encounters errors.

(5) Automatic error corrections

The controller uses 40 bytes ECC and On-The-Fly to automatically correct read errors, without latent rotational time.

Drawing No.	Sheet No.	Revision	2
K6602762	19/38	2002/7/1	

(6) Parameter save feature

The controller saves the controller/device parameters (MODE SELECT parameters) specified by the host onto the disk drive. The parameters are automatically restored at power-on time.

(7) Tagged Command Queuing

A maximum of 110 commands can be enqueued to this drive. The drive does not have to connect and disconnect to the host controller even if the SCSI command has been issued successively, so the overhead time of the SCSI bus can be reduced.

(8) S.M.A.R.T. (Self - Monitoring, Analysis and Reporting Technology)

This function helps predict a failure related to the degradation of the disk drive itself. For users seeking to use the drive as long as possible, S.M.A.R.T. can be used to predict when failure might occur. The user can use this information to back-up the data before failure.

The S.M.A.R.T. report is written on the disk at regular intervals that are not based on drive usage.

(9) Automatic Read Reallocation

When an error is detected on reading the data, this function automatically assigns an alternate sector in place of the defective sector and stores the data on the alternated sector.

(10) Write Cache

The controller can return a completion of a WRITE command with a GOOD status after receiving the data from the host but before writing the data from its buffer to the media. The Deferred Error function reports an Disk Access Error to the host computer if an error occurs when the data are being stored on the disk medium after the GOOD status was already returned. In this case, any data still in the buffer (not yet written to the media) is not assured.

(11) Log Save

Diagnostic information is written on the disk at regular intervals that are not based on drive usage.

Drawing No.	Sheet No.	Revision	2
K6602762	20/38	2002/7/1	

7.2 Summary of SCSI Commands

The SCSI controller supports the group 0,1, and 2 commands listed in Table 7.1

Table 7.1 SCSI Commands Supported

Operation Code	Group 0 Command Name
00h	TEST UNIT READY
01h	REZERO UNIT
03h	REQUEST SENSE
04h	FORMAT UNIT
07h	REASSIGN BLOCKS
08h	READ
0Ah	WRITE
0Bh	SEEK
12h	INQUIRY
15h	MODE SELECT
16h	RESERVE
17h	RELEASE
1Ah	MODE SENSE
1Bh	START/STOP UNIT
1Ch	RECEIVE DIAGNOSTIC RESULTS
1Dh	SEND DIAGNOSTIC
Operation Code	Group 1 Command Name
25h	READ CAPACITY
28h	READ (EXTENDED)
2Ah	WRITE (EXTENDED)
2Bh	SEEK (EXTENDED)
2Eh	WRITE AND VERIFY
2Fh	VERIFY
35h	SYNCHRONIZED CACHE
37h	READ DEFECT DATA
3Bh	WRITE BUFFER
3Ch	READ BUFFER
3Eh	READ LONG
3Fh	WRITE LONG

Drawing No.	Sheet No.	Revision	2
K6602762	21/38	2002/7/1	

Table 7.1 SCSI Commands Supported (Continued)

Operation Code	Group 2 Command Name
41h	WRITE SAME
4Ch	LOG SELECT
4Dh	LOG SENSE
50h	XDWRITE
51h	XPWRITE
52h	XDREAD
55h	MODE SELECT (10)
56h	RESERVE (10)
57h	RELEASE (10)
5Ah	MODE SENSE (10)
5Eh	PERSISTENT RESERVE IN
5Fh	PERSISTENT RESERVE OUT
Operation Code	Group 5 Command Name
A0h	REPORT LUNS

Drawing No.	Sheet No.	Revision	2
K6602762	22/38	2002/7/1	

7.3 Summary of FC-AL

This FC Disk Drive is made based on the Hitachi Disk Drive with Parallel SCSI Interface, and has same basic functions.

However, as the host interface is changed to Fibre Channel, functions depending on the physical host interface is different each other.

This section describes the characteristics of the Hitachi FC Disk Drive changed to have Fibre Channel Interface.

(1) SCSI Interface

Though the physical host interface is changed to Fibre Channel, the FC Disk Drive adopts the SCSI interface as the upper level layer. Therefore, the host can access the FC Disk Drive with almost same manner as the SCSI Disk Drives.

Some functions dependent on physical interface should be different from that of SCSI Disk Drives.

(2) High-speed Data Transfer

The Fibre Channel can transfer data with 200 MB/s. The host can get sufficient throughput even in the environment with multiple devices connected on the same Fibre Channel interface.

(3) Number of devices connected

Based on the Fibre Channel Arbitrated Loop (FC-AL), maximum 126 devices(including host computers) can be connected on the same Fibre Channel. Therefore, a flexible system configurations can be available.

This FC Disk Drive supports the Arbitrated Loop (Private and Public).

(4) Dual Port Function

During the data transferring in one port, this FC Disk Drive can queue commands received in another port.

Drawing No.	Sheet No.	Revision	2
K6602762	23/38	2002/7/1	

Summary of Fibre Channel specifications is shown in Table 7.2

Table 7.2 FC-AL Specifications

No.	Items		Specification
1	Host Interface	Physical	Fibre Channel Arbitrated Loop (FC-AL)
		Logical	SCSI-3
2	Topologies		FC-AL (Private and Public)
3	Service Classes		Class 3
4	Number of Port		2
5	Connection Model		Half Duplex, Full Duplex
6	Access Algorithm		Fairness
7	Number of Host (max.)		16
8	Number of LUN (max.)		1
9	Maximum Frame Size		2112 (B)

Drawing No.	Sheet No.	Revision	2
K6602762	24/38	2002/7/1	

8 Mounting and Handling

8.1 Orientations

The following orientations are acceptable.

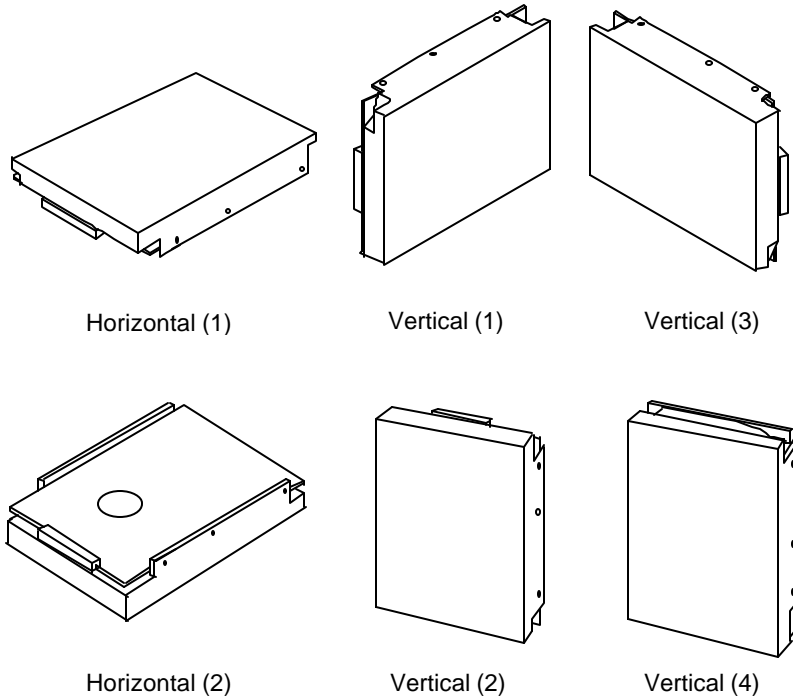

Fig. 8.1 Orientations

Drawing No.	Sheet No.	Revision	2
K6602762	25/38	2002/7/1	

Caution

8.2 Mounting of the drive

1. Mount the drive with four 6-32 UNC screws. (Screw's torque : 0.588 to 0.784 N·m)
2. Mounting holes (A1,A2,B1,B2,B3) are available for mounting.(See figure 8.3)

It is recommended that the 4 holes, (A1,A2 or B1,B3 on figure 8.3), be used for mounting to keep the proper space between mounting holes.

3. Maximum penetration of the screw is 3.8 mm.
4. Keep a clearance of 3 millimeters from the PCB parts side and the HDA's upper surface for proper cooling air ventilation. (See figure 8.2)
5. The mounting chassis's weight shall be more than 2 kg, and the stiffness of mounting chassis shall be more than 196,000 N/m. The stiffness of 4 mounting points shall not be unbalanced.
6. The HDA enclosure is connected to the DC ground on PCB in HDA electrically.

If electrical insulation of the HDA is preferred when it is mounted to the mounting chassis, insert an insulator between the HDA enclosure and the mounting chassis.

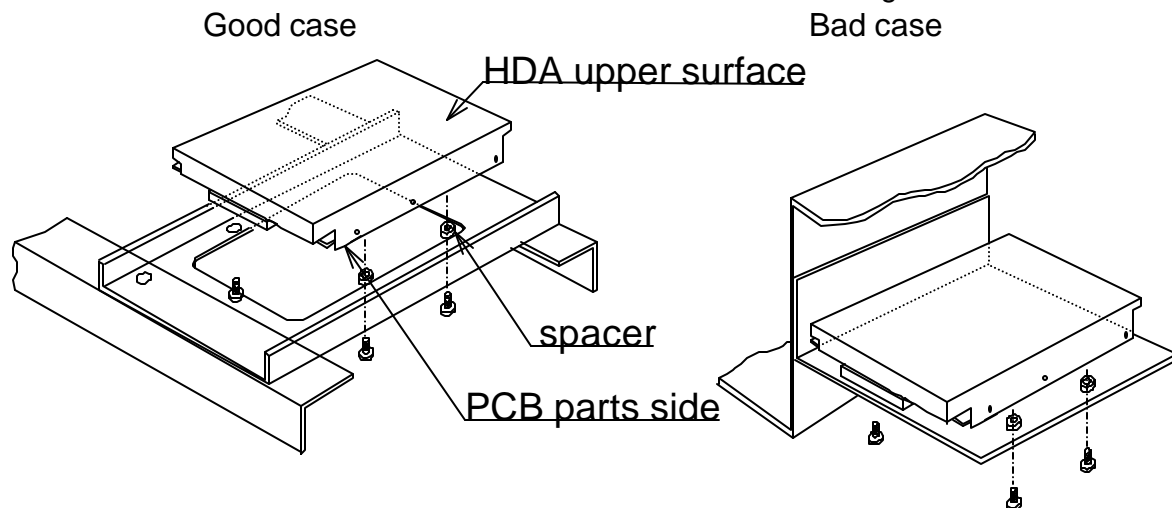
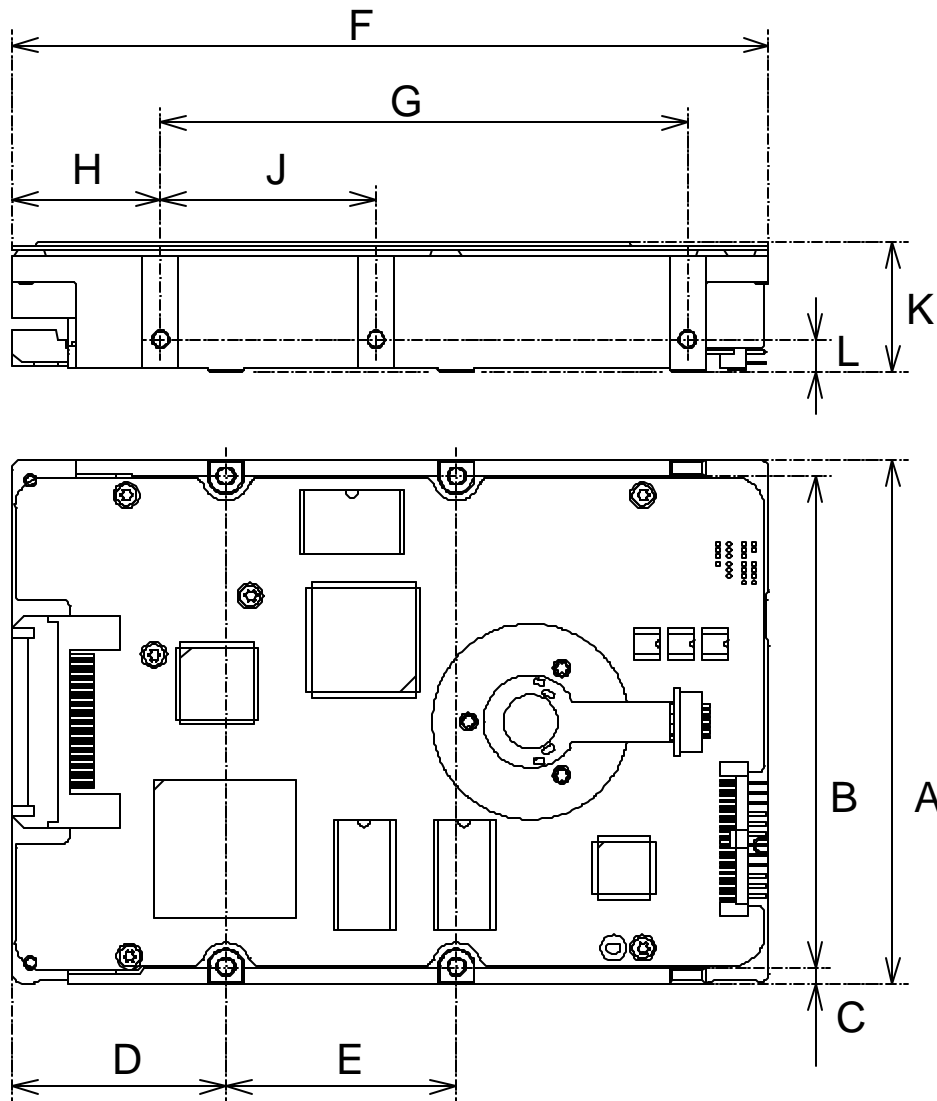

Figure 8.2 Example for mounting

Drawing No.	Sheet No.	Revision	2
K6602762	26/38	2002/7/1	

8.3 Mounting dimensions



Dimension	mm
A	101.6±0.25
B	95.25±0.25
C	3.18±0.25
D	41.28±0.5
E	44.45±0.25
F	147 max.
G	101.6±0.25
H	28.5±0.5
J	41.6±0.25
K	26.1 max.
L	6.35±0.25

Figure 8.3 Layout of Mounting holes

Drawing No.	Sheet No.	Revision	2
K6602762	27/38	2002/7/1	

8.4 Precautions on the off-line test or bench test

When the off-line test or bench test is performed the drive should be tightly fixed and cooled. The set-up should be similar to the actual system configuration.

8.5 Cooling of the drive

Keep the drive (HDA and PCB) cool by using a FAN. Reliability and life of the drive increases as the temperature is lower.

Caution

8.6 Reliability temperature

The temperature measurement points and temperature limits are shown below.

1. The maximum temperature assures the data reliability, seek error rate, and must not be exceeded.
2. The reliability temperature maintains the MTBF of the drive and must not be exceeded in order to ensure its reliability. MTBF is also based on a nominal voltage condition.
3. The maximum temperature of HDA includes momentary temperature rise. Average temperature of HDA has to be less than this temperature.

Table 8.1 Temperature Limits (unit: °C)

Measurement points	HDA(top)	HDA(bottom)	IC(RW)	IC(MPU)
Maximum temperature	65	65	85	85
Reliability temperature	50	50	70	70

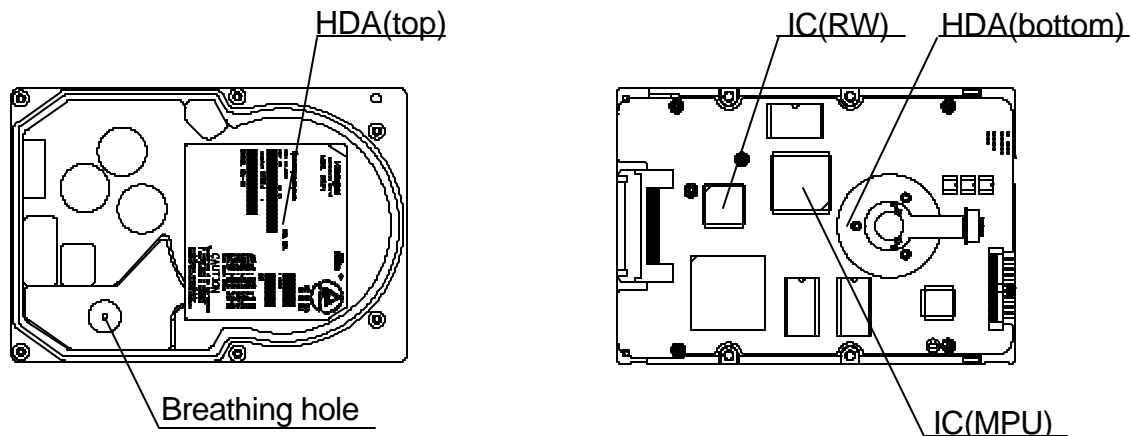

Figure 8.4 Temperature Measurement Points

Drawing No.	Sheet No.	Revision	2
K6602762	28/38	2002/7/1	

Caution

9 Precautions for handling

The drive is sensitive to shock, vibration, over voltage, temperature, humidity, corrosive gas, magnetic force and electrostatic discharge.

If these forces contact the electrical or mechanical components (magnetic heads, magnetic disks), the drive will break down, degrade, or storage data will be lost.

The following handling guidelines are mandatory.

- (1) Handle the drive on the appropriate cushion (for example, anti-static pad with thickness of 10mm or more) to prevent from shock and vibration.
- (2) Handle the drive with a wrist band, an anti-static mat, or without direct touch of the hands to the PCB in order to prevent static electricity discharge.
- (3) Handle the drive in an environment (Temperature, Moisture, Corrosive gas), which follows the drive specification and prevents unforeseen complications.

9.1 Packing

After cleaning the drive, pack it in the following manner to protect it from moisture.

- (1) Put the drive in an electro-static shielding bag with desiccant.
- (2) Packing materials, i.e. electro-static shielding bag, cardboard box, cushion, etc., should not contain corrosive gas, saline or organic-metal compound. (Example organic silicon, organic tin)
- (3) If the package has no damage after unpacking, reserve it for storage or transportation of the drive.

But 20-unit packing material is suitable for only 20 units packing.

When less than 19 units, it is recommended to use the 5-unit packing material.

5-unit packing material covers the quantity from 1 to 5.

9.2 Transportation

- (1) Pack the drive so as to maintain above-mentioned environmental conditions during transportation. (Refer to section 4.2)
- (2) When you take the drive out of the packing case and carry it on a hand truck, lay it on cushioning material (for example, urethane foam cushioning with a thickness of 10mm or more).

9.3 Storage

When storing, pack the drive to protect it against moisture. (Refer to section 4.2)

In case that storage period becomes long, supply power to the HDD, rotate the disks approximately 10 minutes, exchange a desiccant and repack. This operation shall be executed every 3 months.

Drawing No.	Sheet No.	Revision	2
K6602762	29/38	2002/7/1	

9.4 Other Precautions

- 9.4.1 Do not loosen the screws or disassemble the drive.
- 9.4.2 Do not remove the PCB from the drive or swap the PCB with other drives.
- 9.4.3 Do not solder the wire or other parts on the PCB, or reconstruct the PCB.
- 9.4.4 Do not remove the sealing tape or label on the HDA.
- 9.4.5 Turn off the power before removing or installing the jumper.
- 9.4.6 Remove the DC power and SCSI interface connectors carefully in order not to damage the contact pins and the connector housing.
- 9.4.7 Do not move the drive when the disks are rotating or while the power is on or for 20 seconds after the power has been turned off.
- 9.4.8 Do not cover the breathing hole on the surface of the drive with use of a seal. (The position of the breathing hole is shown in Figure 8.4.)

10 Maintenance

- 10.1 The HDD itself is maintenance free and there are no individual parts that require maintenance. If maintenance for the HDD is required, the entire product will need to be serviced, since it can not be divided into parts. System maintenance should be executed by the host system.
- 10.2 The supplier will repair or exchange the product due to malfunction covered under the warranty. The warranty and service will be agreed upon between the customer and the supplier. The supplier is neither liable or obligated to service any product due to carelessness or mishandling of product.
- 10.3 Even if the drive fault occurs during the In-warranty period, the supplier will repair or replace the drive but will not be liable for any expenses of disk drive installation or detachment to or from system. (This includes data back up, data copy, etc.)

Drawing No.	Sheet No.	Revision	2
K6602762	30/38	2002/7/1	

11 Physical interface

11.1 Connector Specifications

Use the mating connectors which are electrically and mechanically compatible.
The following part numbers indicate the mating connectors.

Table 11.1 Interface connectors

Interface	Name	Part number	Manufacturer
SCA-2 Fibre Channel	SCSI interface connector	787317-1	AMP
	with DC power connector	HD2-RA040-S111	DDK

11.2 Port Bypass Circuit

Fibre Channel drives may be connected in a loop together or with other compatible FC-AL devices. A maximum of 126 addresses are available for FC-AL devices.

Port bypass circuits (PBCs) allow devices to be inserted into unpopulated locations or removed from the loop with loop operation recovery after a brief disruption. These PBCs are located external to the FC-AL device. Figure 11.1 shows the relationship between PBC and FC-AL device.

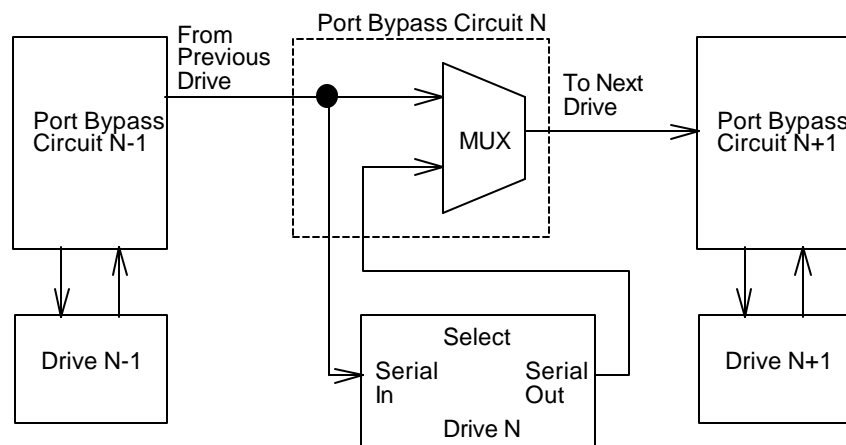
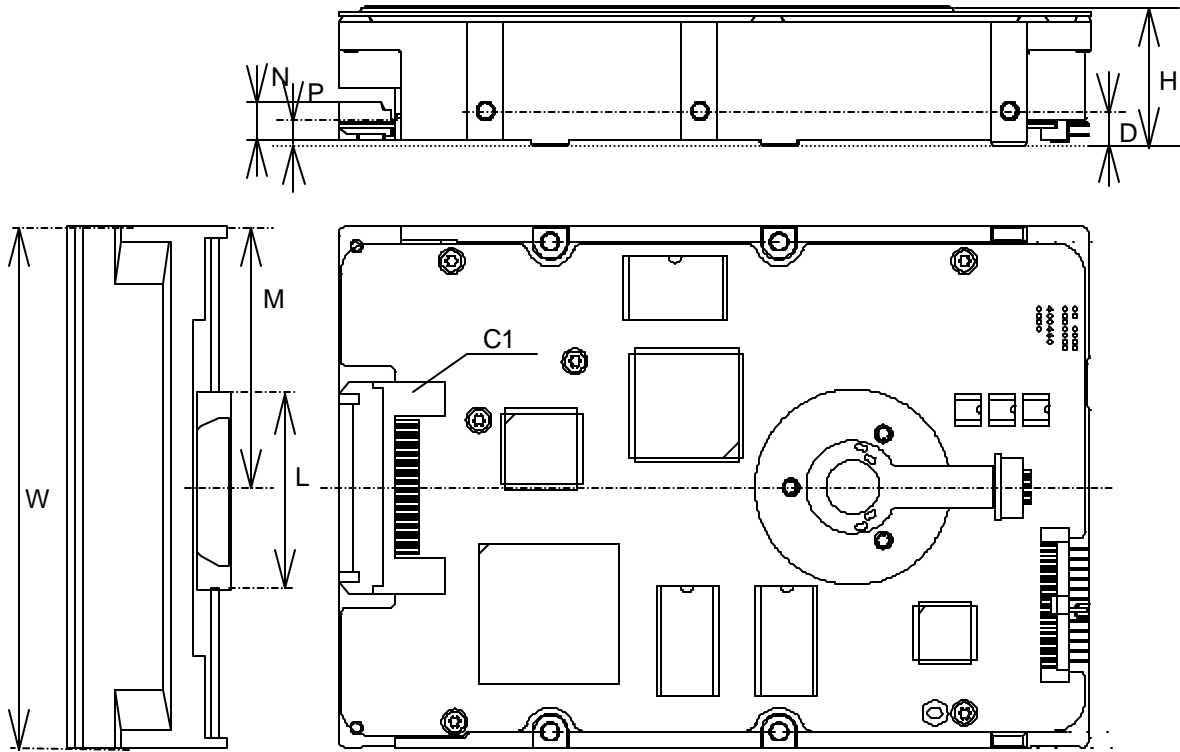

Figure 11.1 Port bypass circuit physical interconnect

Drawing No.	Sheet No.	Revision	2
K6602762	31/38	2002/7/1	

11.3 Connector Layout
 SCA-2 Fibre Channel



Dimension	mm	Dimension	mm
H	26.1 max.	W	101.6±0.25
D	6.35±0.25	L	(30)
N	(7)	M	50.8±0.5
P	4.6±0.5		

Figure 11.2 Connector Layout (SCA-2 Fibre Channel)

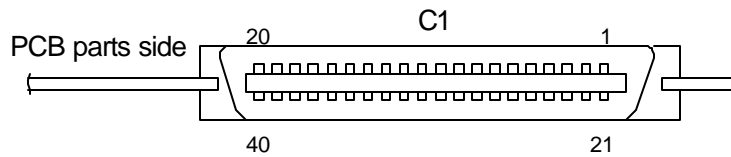

Figure 11.3 Connector view

Drawing No.	Sheet No.	Revision	2
K6602762	32/38	2002/7/1	

12 Pin assignment

12.1 SCSI Bus Connector C1

**Table 12.1 Pin assignment of SCSI Bus Connector C1
(SCA-2 Fibre Channel)**

Signal Name	Connector contact No.		Signal Name
-EN Bypass Port 1	1	21	12V
12V	2	22	GND (12V Return)
12V	3	23	GND (12V Return)
12V	4	24	+IN1
-Parallel ESI	5	25	-IN1
GND	6	26	GND (12V Return)
ACTLED	7	27	+IN2
Reserved	8	28	-IN2
START1	9	29	GND (12V Return)
START2	10	30	+OUT1
-EN Bypass Port 2	11	31	-OUT1
SEL6	12	32	GND (5V Return)
SEL5	13	33	+OUT2
SEL4	14	34	-OUT2
SEL3	15	35	GND (5V Return)
FLTLED	16	36	SEL2
DEVCTRL2	17	37	SEL1
DEVCTRL1	18	38	SEL0
5V	19	39	DEVCTRL0
5V	20	40	5V

Drawing No.	Sheet No.	Revision	2
K6602762	33/38	2002/7/1	

12.2 Other connectors

Table 12.2 Pin assignment of Option Jumper Connector C3 (SCA-2 Fibre Channel)

Pin No.	Signal Name	Pin No.	Signal Name	Note
1	Reserved	2	5V	
3	Reserved	4	5V	
5	FLTLED	6	5V (with 150 ohm)	See Figure 12.1
7	Reserved	8	GND	
9	Reserved	10	GND	
11	Reserved	12	GND	
13	Reserved	14	GND	
15	-WRITE PROTECT	16	GND	
17	Reserved	18	GND	
19	Reserved	20	GND	
21	ACTLED	22	5V(with 150 ohm)	See Figure 12.1
23	Reserved	24	Not Connected	

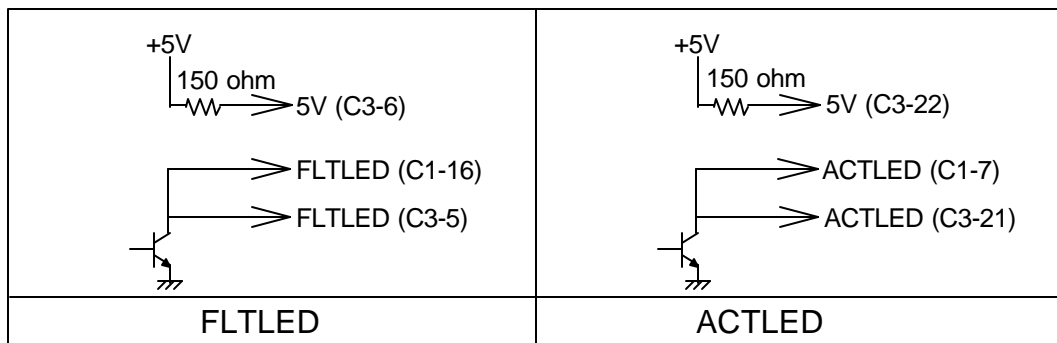

Figure 12.1 LED Driver (SCA-2 Fibre Channel)

The FLTLED and ACTLED are designed to pull down the cathode of an LED. The anode is attached to the proper 5V supply through an appropriate current limiting resistor. In case of driving the external LED using C1-16 and/or C1-7, external current limiting resistor is required. See table 12.3 for the output characteristics of the FLTLED and ACTLED drive signals.

Table 12.3 FLTLED and ACTLED drive signals

State	Current Drive Available	Output Voltage
LED off, high	$-100\mu\text{A} < I_{OH} < 100\mu\text{A}$	
LED on, low	$I_{OL} > 30\text{mA}$	$0 < V_{OL} < 0.5\text{V}$

Drawing No.	Sheet No.	Revision	2
K6602762	34/38	2002/7/1	

12.3 Device control codes

The drive has a Device Control Code on the DEVCTRL lines to determine the link rate on the Fibre Channel ports. Both ports run at the same rate. If these lines are not connected to the backplane, the drive has 10k ohm pull up resistors that default the device control code to 7. Definition of the codes are shown in Table 12.4.

Table 12.4 Device control code values

DEVCTRL2	DEVCTRL1	DEVCTRL0	Value	Definition
0	0	0	0	Reserved
0	0	1	1	Reserved
0	1	0	2	Reserved
0	1	1	3	Reserved
1	0	0	4	Reserved
1	0	1	5	Reserved
1	1	0	6	2.125Gbps operation on both ports
1	1	1	7	1.0625Gbps operation on both ports

12.4 Enable Port Bypass

The -EN Bypass Port 1 and -EN Bypass Port 2 signals control the port bypass circuits (PBC) located external to the drive. The PBC allows a loop to remain functional in the event of a drive failure or removal. When these signals are active (low), the PBC bypasses the drive on the associated port. If the drive is not installed, a pull down resistor, 1k ohm, located with the PBC should be used to insure the bypass is enabled.

12.5 -Parallel ESI and SEL0-6

The -Parallel ESI is an output from the drive. This signal provides the enclosure with an indication of the present function of the SEL0-6 lines. When the -Parallel ESI is high, the enclosure must provide address information on the SEL0-6 lines. The drive has 39k ohm pull up resistors on the SEL0-6 lines. The backplane is required to provide high and low inputs to the SEL0-6 lines by using proper pull up or pull down resistors (10k ohm or less). When the -Parallel ESI is low, the enclosure switches to Enclosure Service Interface (ESI) mode. Refer to the Fibre Channel Interface Specification Manual for DK32EJ for a description of ESI operation.

Drawing No.	Sheet No.	Revision	2
K6602762	35/38	2002/7/1	

13 Jumper Socket setting

13.1 Jumper connector layout

SCA-2 Fibre Channel

Option Jumper Connector (C3)

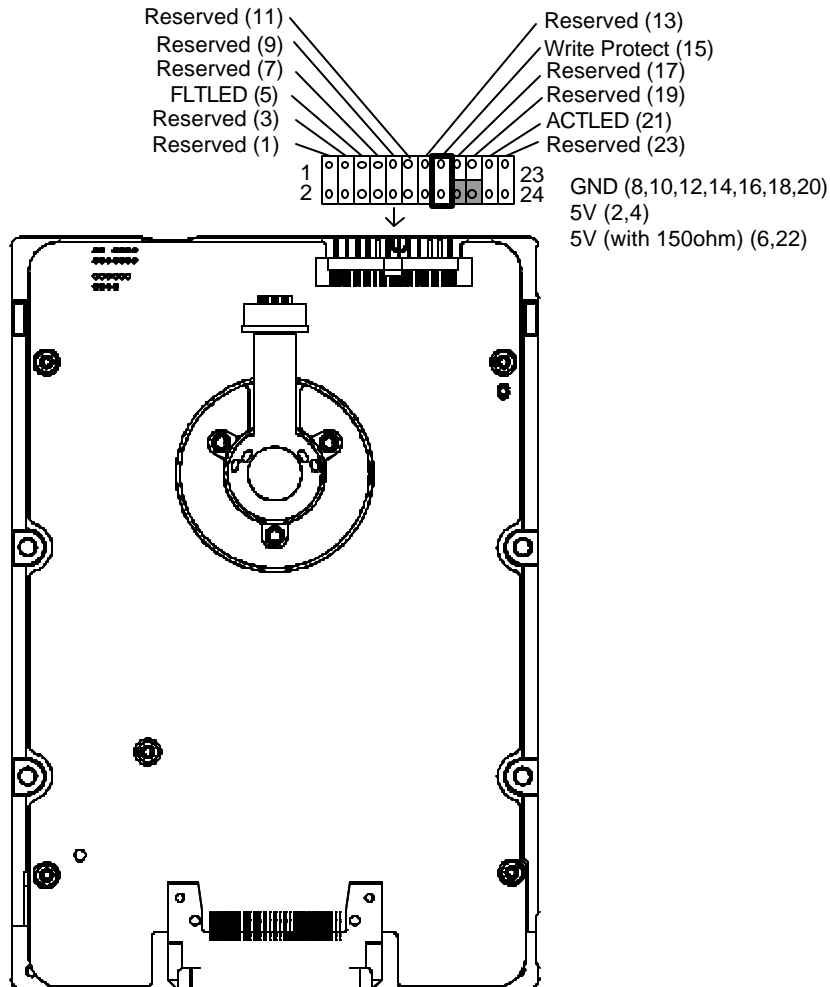

Figure 13.1 Jumper connector layout (SCA-2 Fibre Channel)

Note 1. Jumper sockets are used for the customer's selection. (They are shown with thick lines in figure 13.1)

2. Shaded jumper sockets are default setting at the factory.

3. Reserved pins (C3-1,3,7,9,11,13,17,19) are used at the factory. Installing or removing jumper sockets on these reserved pins will void any warranties of the HDD.

Do not connect an assigned pin to another assigned pin.

4. A jumper is installed at C3-18,20 as a spare. Customer can remove and use it for write protection.

Drawing No.	Sheet No.	Revision	2
K6602762	36/38	2002/7/1	

13.2 Jumper socket setting

The Jumper sockets should be set only when the power is off.

13.2.1 Write Protect

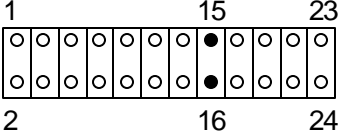
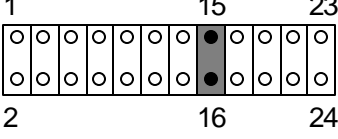
No.	Option Jumper Connector (C3)	Meaning
1	<p>Remove the Jumper Socket for C3-15,16 (Default)</p>  <p>The diagram shows a 24-pin connector with two rows of 12 pins each. The top row is labeled 1 to 23, and the bottom row is labeled 2 to 24. Pin 15 is the 10th pin in the top row, and pin 16 is the 10th pin in the bottom row. Both pins 15 and 16 are unpopulated, indicated by a solid black dot in the center of each pin's circle.</p>	Write enabled
2	<p>Install the Jumper Socket for C3-15,16</p>  <p>The diagram shows a 24-pin connector with two rows of 12 pins each. The top row is labeled 1 to 23, and the bottom row is labeled 2 to 24. Pin 15 is the 10th pin in the top row, and pin 16 is the 10th pin in the bottom row. Both pins 15 and 16 are populated, indicated by a solid black dot in the center of each pin's circle. The area around the populated pins is shaded gray.</p>	Write protected

Drawing No.	Sheet No.	Revision	2
K6602762	37/38	2002/7/1	

13.3 Jumper socket part number

Part numbers of jumper sockets are as follows:

Table 13.1 Jumper socket

Connector	Name	Part number	Manufacturer
Option Jumper Connector (C3)	MINITEK JUMPER	86730-001	FCI Japan K.K.

Drawing No.	Sheet No.	Revision	2
K6602762	38/38	2002/7/1	