

IBM OEM Storage Products

DPES-30540, DPES-30810, DPES-31080

IBM OEM has introduced a new range of disk drives for the desktop personal computer marketplace. Available in three popular capacity points with SCSI-2 FAST interface, the drives provide excellent performance and improved reliability.

APPLICATIONS

- Desktop personal computers
- Low end file servers
- Low end workstations

FEATURES

- 540, 810 and 1080 MB formatted capacities
(512 byte/sector)
- 10 MB/s data transfer speed
- 55.1 Mb/s (OD) media data rate
39.8 Mb/s (ID) media data rate
- No sector ID format
- Average seek time 10.5 ms (Read)
- 5400 RPM
- 448 KB sector buffer with adaptive segment length
- Read ahead caching with LRU segment update
- Industry standard mounting
- The drive can be counted with any of its six surfaces facing down
- Enhanced ECC implementation
- Power saving modes
- Robust design for EMC/FRI
- MR (Magneto Resistive) head technology

BENEFITS--

- Generic range of popular storage capacity
- Fast interface data rate
- Excellent performance on long records
- Fast access to data
- Fast data retrieval in single and multi-tasking applications
- Ease of installation
- Improved data throughput

- Reduced power consumption
- Easy integration across multiple platforms
- High area density, low component count
- Assured reliability

CONNECTORS

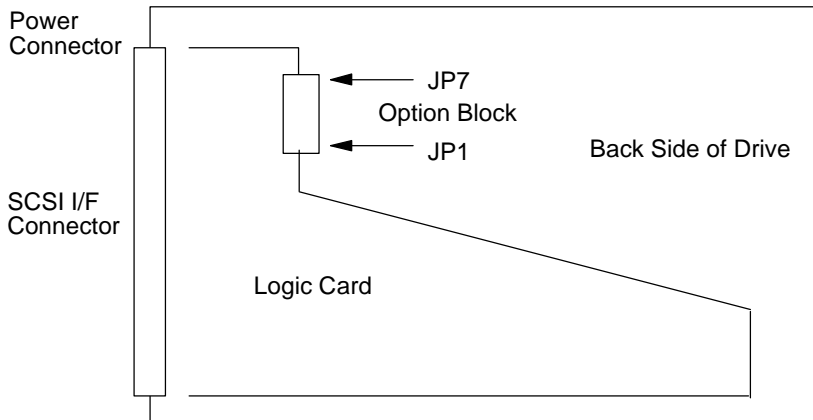
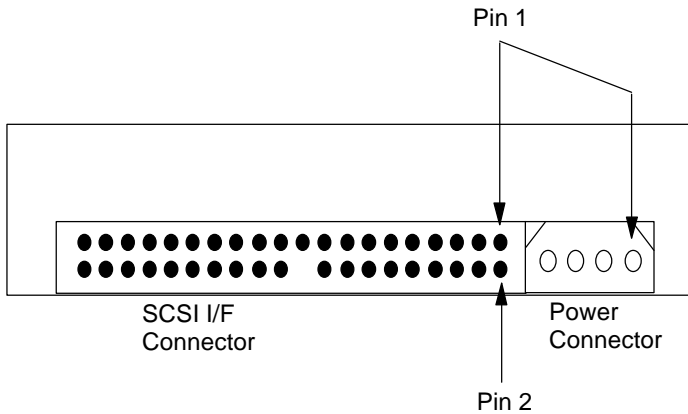

The DC power connector is designed to mate with AMP part 1-480424 (using AMP pins P/N 350078-4). Equivalent connectors may be used. Pin assignments are shown below, as viewed from the end of the drive.

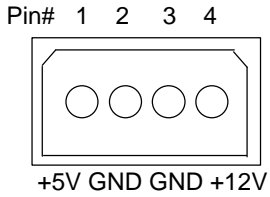

SCSI SIGNAL CONNECTOR

The SCSI Signal Connector is a 50 pin connector meeting the ANSI SCSI specification

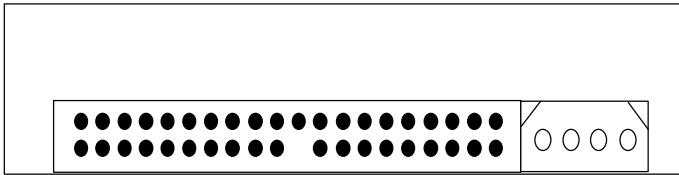

Note: It is intended that the hard disk drive should only be in electrical contact with the chassis of the PC at a designated set of mounting holes. Other electrical contact may degrade error rate performance. As a result of this it is recommended that there should be no metal contact to the hard disk drive except at the mounting holes or the side rails into which the mounting holes are tapped.

OPTION BLOCK

Jumpers Setting

Jumpers position and function are as shown below. Pin pitch is 2 mm.

The jumpers control SCSI Device ID, Auto Spin Up, Unit Attention, SCSI Terminator Connection, and Target Initiated Synchronous Negotiation.

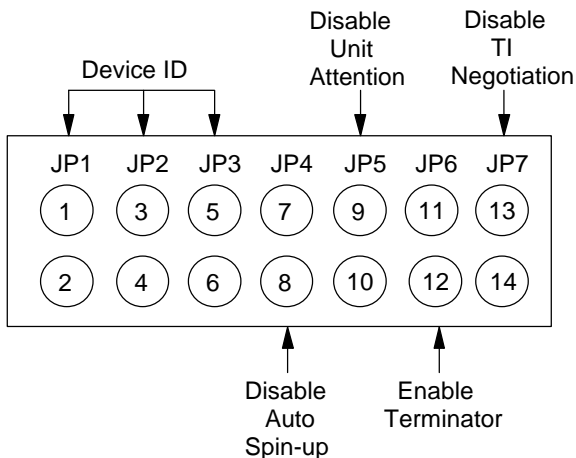

Notes:

1. The jumper position of JP1, 2, and 3 define SCSI ID of the drive If JP1,JP2,JP3 are Off,Off,Off the SCSI ID is 0 (shipping default) If JP1,JP2,JP3 are On,Off,Off the SCSI ID is 1 If JP1,JP2,JP3 are Off,On,Off the SCSI ID is 2 If JP1,JP2,JP3 are On,On,Off the SCSI ID is 3 If JP1,JP2,JP3 are Off,Off,On the SCSI ID is 4 If JP1,JP2,JP3 are On,Off,On the SCSI ID is 5 If JP1,JP2,JP3 are Off,On,On the SCSI ID is 6 (set at shipping) If JP1,JP2,JP3 are On,On,On the SCSI ID is 7

2. If JP4 is Off, the drive will spin up automatically after power on reset. If JP4 is On, the drive will not spin up unless the host system issues a start command to the drive with the start bit set to one.
3. If JP5 is On, Unit Attention after power on reset or SCSI bus reset is disabled.
4. If JP6 is On, the internal SCSI active terminator works.
5. If JP7 is On, Target Initiated Synchronous Negotiation is disabled, and then the Initiator is required to start a negotiation handshake if Synchronous SCSI transfers are desired.

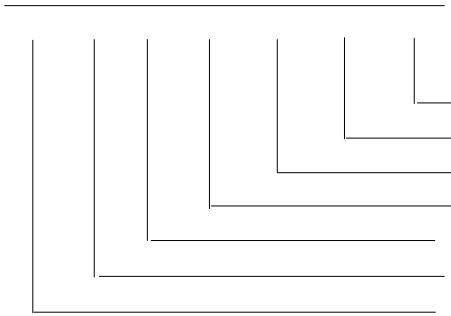

OPERATING ENVIRONMENT

Operating Conditions

| | |
|---------------------------------|-------------------------------|
| Temperature | 5 to 55 degrees C* |
| Relative Humidity | 8 to 90% non-condensing |
| Maximum Wet Bulb Temperature | 29.4 degrees C non-condensing |
| Maximum Temperature Gradient | 15 C/Hour |
| Altitude | -300 to 3048m |

Non-Operating Conditions

| | |
|---------------------------------|-----------------------------|
| Temperature | -40 to 65 degrees C |
| Relative Humidity | 5 to 95% non-condensing |
| Maximum Wet Bulb Temperature | 35 degrees C non-condensing |
| Maximum Temperature Gradient | 15 C/Hour |
| Altitude | -300 to 12,000m |

*Note** The system is responsible to provide sufficient air movement to maintain surface temperature below 60 C at the center of top cover of the drive.

Operating Shock

The hard disk drive meets the following criteria while operating in respective conditions described below. The shock test consists of five shocks inputs in each axis and direction for total of 30. There must be a delay between shock pulses, long enough to allow the drive to complete all necessary error recovery procedure.

No data loss, seek error or permanent damage:

10G 11 ms half-sine shock pulse

No data loss, or permanent damage:

15 G, 5 ms half-sine shock pulse

30 G, 4 ms half-sine shock pulse

Operating Vibration

Due to the complexity of this subject we recommend that users contact the IBM technical support group representative to discuss how to perform the necessary measurements if they believe this to be an area which requires evaluation.

DC POWER REQUIREMENTS

The following voltage specifications apply at the file power connector. Damage to the file electronics may result if the power supply cable is connected or disconnected while power is being applied to the file (No hot plug/unplug is allowed). There are inductive loads in the file which could cause destructively high voltage spikes on the file if the power connection is opened. There is no special power on/off sequencing required.

| | | |
|---|----------|--------------------|
| Nominal Supply Voltages | +5 volts | +12 volts |
| Power Supply Ripple {mV}{0-10{MHz}P-P) | 100 max | 150 max (2) |
| Tolerance | +/-5% | +10%/-8% |
| Supply Current (Populated Mean) | | |
| Idle (average) | 0.26 | 0.12/0.16 {A/B(1)} |
| R/W (average) | 0.62 | 0.24/0.28 {A/B(1)} |
| Seek (average) | 0.46 | 0.34/0.37 {A/B(1)} |
| Standby | 0.22 | 0.02 |
| Start up (Peak) | 0.64 | 1.20 |

Notes:

(1) A/B shows that A is for DPES-30540 and B is for DPES-30810 and DPES-31080.

(2) The maximum ripple is measured at input of the drive.

(3) The drive does not incur damage by an over-voltage condition of +25% and the maximum duration of 20 {msec}.

During the file start up and seeking, 12 volt ripple is generated by the file (referred to as dynamic loading). If several files have their power daisy chained together then the power supply ripple plus other file's dynamic loading must remain within the regulation tolerance of +10/-8%. A common supply with separate power leads to each file is a more desirable method of power distribution.

To prevent external electrical noise from interfering with the file's performance, the file must be held by four screws in a user system frame which has no electrical level deference at the four screws position, and has less than +/-300 millivolts peak to peak level deference to the file power connector ground.

DATA ORGANIZATION

| | | | |
|--------------------|-----------|-----------|------------|
| Logical Layout | DPES | DPES | DPES |
| | -30540 | -30810 | -31080 |
| Bytes per Sector | 512 | 512 | 512 |
| Number of Heads | 2 | 3 | 4 |
| Number of Disks | 1 | 2 | 2 |
| Number of LBAs | 1058400 | 1586592 | 2116800 |
| Total logical Data | 514900800 | 812335104 | 1083801600 |
| Bytes | | | |

SIGNAL DEFINITION

The pin assignments of interface signals are listed as follows:

| | | | |
|-----|--------|-----|-----------|
| PIN | Signal | PIN | Signal |
| 01 | Ground | 02 | -DB(0) |
| 03 | Ground | 04 | -DB(1) |
| 05 | Ground | 06 | -DB(2) |
| 07 | Ground | 08 | -DB(3) |
| 09 | Ground | 10 | -DB(4) |
| 11 | Ground | 12 | -DB(5) |
| 13 | Ground | 14 | -DB(6) |
| 15 | Ground | 16 | -DB(7) |
| 17 | Ground | 18 | -DB(P) |
| 19 | Ground | 20 | Ground |
| 21 | Ground | 22 | Ground |
| 23 | Ground | 24 | Ground |
| 25 | Open | 26 | TRM Power |
| 27 | Ground | 28 | Ground |
| 29 | Ground | 30 | Ground |
| 31 | Ground | 32 | -ATN |

| | | | |
|----|--------|----|--------|
| 33 | Ground | 34 | Ground |
| 35 | Ground | 36 | -BSY |
| 37 | Ground | 38 | -ACK |
| 39 | Ground | 40 | -RST |
| 41 | Ground | 42 | -MSG |
| 43 | Ground | 44 | -SEL |
| 45 | Ground | 46 | -C/D |
| 47 | Ground | 48 | -REQ |
| 49 | Ground | 50 | -I/O |

SCSI CABLE

The disk drive uses single-ended drivers and receivers which will permit cable lengths of up to 6 meters (19.68 feet). For a single ended cable a 50 conductor flat cable or a 25 signal twisted cable can be used with a maximum length of 6.0 meters, and a stub length not exceeding 0.1 meters.

SCSI BUS TERMINATOR

The file has an internal Active SCSI bus terminator, and can be controlled on/off with one jumper block provided at the card edge. The user is responsible for properly terminating and powering the SCSI bus in the system.

MODE SELECT OPTIONS

Certain parameters are alterable using the SCSI 'Mode Select' command. This allows certain drive characteristics to be modified to optimize performance on a particular system. Refer to the DPES-3XXXX Interface Specification for a detailed definition of Mode Select parameters. The changeable parameters are:

Page 0

Vendor Unique Parameters

UQE - Untagged Queuing Enable (1)

DWD - Disable Write Disconnect (0)

UAI - Unit Attention Inhibit (0)

ASDPE - Additional Save Data Pointer Enable (0)

CMDAC - Command Activated (LED) (0)

RPFAE - Report Failure Analysis Error (0)

CPE - Concurrent Processing Enable (1)

TCC - Thermal Compensation (0)

DSN - Disable Target Initiated Synchronous Negotiation (0)

FRDD - Format Degraded (1)

DPSDP - Data Phase Save Data Pointer (0)

CAEN - Command Age Limiter Enable (1)

LITF - Idle Time Function (0)
ADC - Adaptive Cache Enable (1)
QEMC - Queue Error Management Control (0)
DRD - Disable Read Disconnect (1)
LED - Not supported (0)
Command Aging Limit (48)
DRRT - Disable Read Reassign Target (0)
DNR - Disable Nested Reassigns (1)

Page 1

Read-Write Error Recover Parameters
AWRE - Automatic Write Reallocation Enable (1)
ARRE - Automatic Read Reallocation Enable (1)
TB - Transfer Block (0)
PER - Post Error (0)
DTE - Disable Transfer on Error (0)
DCR - Disable Correction (0)
Read Retry Count (01h)
Write Retry Count (01h)

Page 2

Disconnect/Reconnect Parameters
Read buffer Full Ratio (00h)
Write Buffer Empty Ratio (00h)

Page 7

Verify Error Recovery Parameters
PER (0)
DCR (0)
Verify Retry Count (01h)

Page 8

Caching Parameters
WCE - Write Cache Enable (1)
RCD - Read Cache Disable (0)
MF - Multiplication Factor (0)
Disable Pre-Fetch Transfer Length (0)
Minimum Pre-Fetch (0)
Maximum Pre-Fetch (0)
Maximum Pre-Fetch Ceiling (0)
Number of Cache Segments (7)

Page A

Control Mode Page Parameters
Queue Algorithm Modifier (0)

QErr - Queue Error (00h)
DQue - Disable Queing (0)

Page 0D

Power Condition

Standby (0)

Standby Timer (00h)

Note: (xx) default options at Shipment

MECHANICAL DATA

Dimensions

Height 25.4 +/-0.4 mm
Width 101.6 +/-0.4 mm
Depth 146.0 +/-0.6 mm
Weight 530 g maximum

Mounting Orientation

The drive can be mounted in any axis (6 directions)

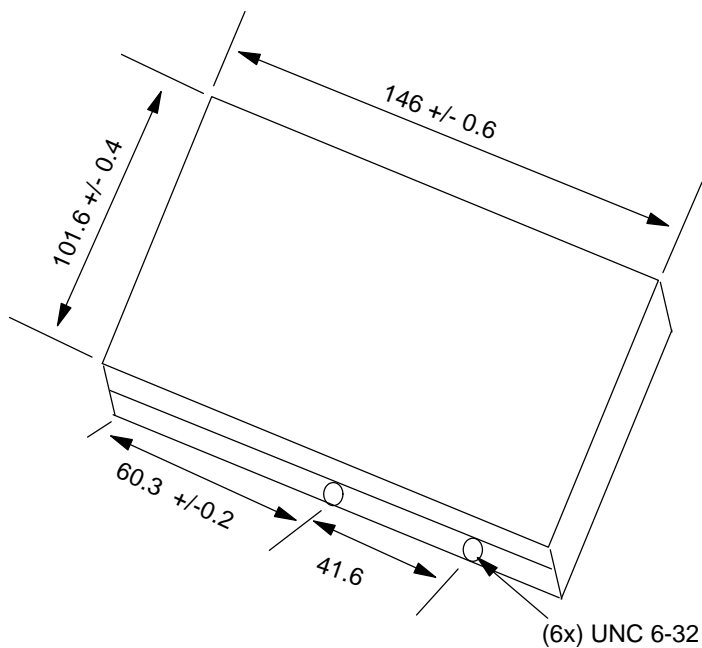

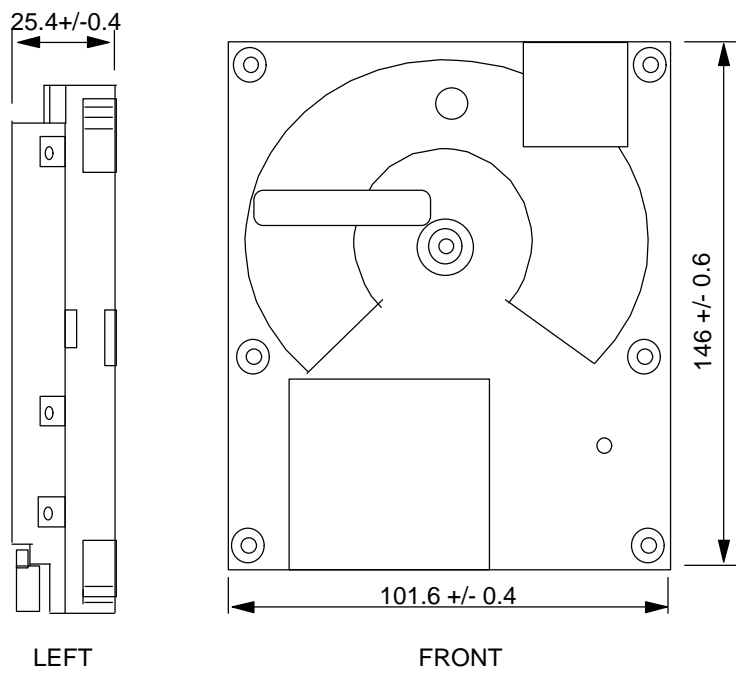
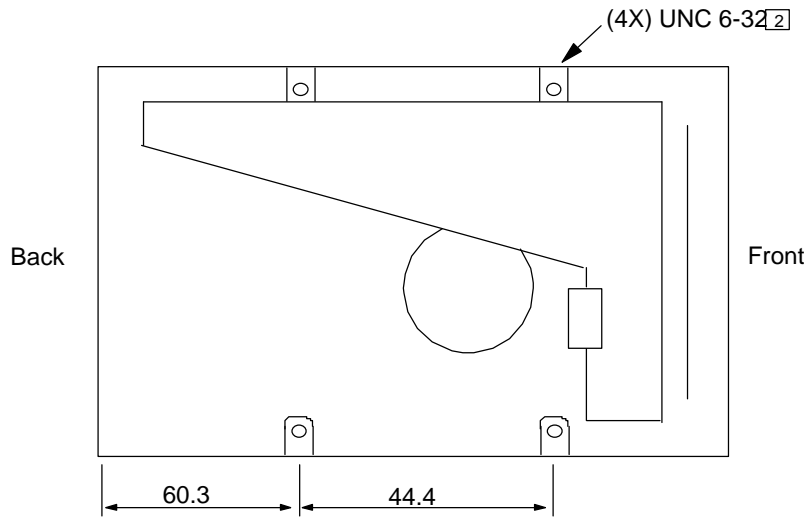

The maximum allowable penetration of the mounting screws is (1) 3.5 mm (2) 6 mm

ELECTROMAGNETIC COMPATABILITY

The drive meets the following EMC requirements when installed in the user system and exercised with a random accessing routine at maximum data rate:

United States Federal Communication Commission (FCC) Rules and Regulations Part 15, Subject J - Computer Devices "Class B Limits".

European Economic Community (EEC) directive #76/889 related to the control of radio frequency interference and the Verband Deutscher Elektrotechniker (VDE) requirements of Germany (GOP).

AMP is a trademark of AMP Incorporated.

Molex is a trademark of Molex Incorporated.

DATA MATE is a trademark of AMP Incorporated.

This data sheet is not a substitute for the full product specification, which should be used when detailed information is required.

Product Description data represents IBM's design objectives and is provided for comparative purposes; actual results may vary based on a variety of factors. This product data does not constitute a warranty. Questions regarding IBM's warranty terms or methodology used to derive this data should be referred to your IBM OEM representative. Data subject to change without notice.



WARNING: This disk drive can be damaged by Electro-Static Discharge, please follow recommended ESD procedures before unpacking or handling the drive. Ask your dealer for details if you need assistance.



PACKAGING: The drive must be protected against Electro-Static Discharge especially when being handled. The safest way to avoid damage is to put the drive in an anti static bag before ESD wrist straps are removed. Drives should only be shipped in approved containers, severe damage can be caused to the drive if the packaging does not adequately protect against the shock levels induced when a box

is dropped. Consult your IBM marketing representative if you do not have an approved shipping container.