

Product summary

Deskstar 120GXP

Ultra ATA/100



Models: IC35L020AVVN07
 IC35L020AVVA07
 IC35L040AVVN07
 IC35L040AVVA07
 IC35L060AVVA07
 IC35L080AVVA07
 IC35L100AVVA07
 IC35L120AVVA07

Introduction	Applications
<p>IBM's latest Deskstar drive is ideal for high performance desktop users. These drives feature capacities from 20 GB up to 120 GB, a rotational speed of 7200 RPM, and average seek times of 8.2 and 8.5 ms. The Deskstar 120GXP combines new and proven technologies to greatly enhance system performance and capacity.</p>	<ul style="list-style-type: none"> Advanced desktop and audio/video Low-cost routers Switches Video editing
Features	Advantages
<ul style="list-style-type: none"> Formatted capacities of 20, 40, 60, 80, 100 & 120 GB Rotational speed 7200 RPM 	<ul style="list-style-type: none"> Supports higher quality digital audio/video storage, superior digital content creation capabilities, and significantly faster processing
<ul style="list-style-type: none"> Ultra ATA/100 interface Self Diagnostics on Power On and resident diagnostics 	<ul style="list-style-type: none"> Optimizes system performance
<ul style="list-style-type: none"> Operating shock—No data loss occurs with a 55 G half-sine shock pulse of 2 ms duration 	<ul style="list-style-type: none"> Protection for drive mishandling Increased reliability
<ul style="list-style-type: none"> Idle power consumption of 6.7 Watts Circuits and motors optimized to save power and reduce system temperature 	<ul style="list-style-type: none"> Lower system power supply and cooling requirements Extending system life and reliability
<ul style="list-style-type: none"> 2048 KB data buffer (upper 184.5 KB for firmware) Media-to-buffer transfer rates: up to 592 Mb/s (high tracks/inch) – up to 627 Mb/s (low t/i) Average seek time: 8.5 ms (IC35L020AVVN07 & IC35L040AVVN07), 8.2 ms (all other models) Average latency: 4.17 ms Complies with ATA5 specification 	<ul style="list-style-type: none"> Fast access to data Improved throughput
<ul style="list-style-type: none"> Ceramic spindle bearings and tri-laminate top cover reduce acoustics to 3.0 & 3.1 Bels (depending on model - see page 3) 	<ul style="list-style-type: none"> Lower acoustics
<ul style="list-style-type: none"> Glass substrate disks 	<ul style="list-style-type: none"> Greater rigidity to reduce the impact of shock Smoother disc surface Reduced head fly height, improved disk readability

Connectors

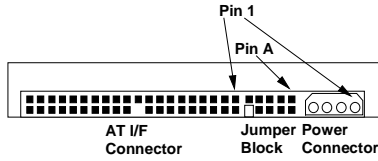

The DC power connector is designed to mate with AMP p/n 1-80424-0 using AMP strip pins (p/n 350078-4), loose piece pins (p/n 61173-4), or their equivalents.

Note: The AT signal connector is a 40-pin connector.

Cabling

The length of the cable from the host system to the drive must not exceed 18 inches.

For systems operating with Ultra DMA mode 3, 4, or 5, the 80-conductor ATA cable assembly must be used.

Jumper block

Jumper pin letter designations

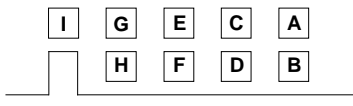

A jumper attaches two pins together to configure the drive for the proper mode of operation.

Jumper settings

16 head logical architecture

Master active*	A-B and G-H
Slave active	A-B and C-D
Cable Select	A-B and E-F
Master/Slave present	E-F and G-H
Reserved	I

15 head logical architecture

Master active	A-C and G-H
Slave active	A-C
Cable select	A-C and E-F
Master/Slave present	A-C, E-F & G-H
Reserved	I

All other jumper settings are reserved. Do not make other settings!

*Shipping default

DC power requirements

Damage to the drive electronics may result if the power supply cable is connected or disconnected while the power is on. There is no special power on/off sequencing required. The following voltage specification is applied at the power connector of the drive.

Input voltage (Volts)	During run and spin up (Volts)	Absolute max spike voltage
+5	5 ± 5%	7 ¹
+12	12 +10% -8%	15 ¹

¹Power supply voltage spikes in excess of the maximum values specified in the table may damage the drive electronics.

Power supply current

	mA RMS +5 V	mA RMS +12V	Total Watts
--	-------------	-------------	-------------

IC35L120AVVA07			
IC35L100AVVA07			
Idle avg	310	390	6.2
Idle ripple – peak to peak	370	370	–
Seek peak	600	820	–
Seek avg ¹	380	470	7.5
Start up-max	740	1867	–
RND R/W peak	790	1800	–
RND R/W avg ²	470	590	9.4
Standby avg	160	15	1.0
Sleep avg	150	15	0.9

IC35L080AVVA07			
IC35L060AVVA07			
Idle avg	310	320	5.4
Idle ripple – p to p	370	320	–
Seek peak	600	740	–
Seek avg ¹	380	400	6.7
Start up-max	740	1800	–
RND R/W peak	790	1700	–
RND R/W avg ²	470	540	8.8
Standby avg	160	15	1.0
Sleep avg	150	15	0.9

IC35L040AVVA07			
IC35L020AVVA07			
Idle avg	310	290	4.9
Idle ripple – p to p	330	80	–
Seek peak	600	700	–
Seek avg ¹	370	360	6.2
Start up-max	730	1800	–
RND R/W peak	780	1700	–
RND R/W avg ²	460	500	8.3
Standby avg	160	15	1.0
Sleep avg	150	15	0.9

IC35L040AVVN07			
IC35L020AVVN07			
Idle avg	303	270	4.9
Idle ripple – p to p	273	312	–
Seek peak	550	705	–
Seek avg ¹	364	336	6.2
Start up-max	713	1700	–
RND R/W peak	738	1520	–
RND R/W avg ²	454	488	8.3
Standby avg	156	15	1.0
Sleep avg	139	15	0.9

¹ Random seeks at 40% duty cycle

² Seek duty = 30%, W/R duty = 45%, Idle Duty = 25%

Power supply generated ripple

Output (V)	Maximum (mV p-p)	Freq. range (MHz)
+5	100	0–10
+12	150	0–10

Hot Plug/Unplug support

Hot plugging/unplugging is not allowed. Damage to the drive electronics may result if the power supply cable is connected or disconnected while power is being applied to the drive.

Data organization (logical)

Number of heads	16
Sectors/track	63
Number of cylinders	16,383

Drive Capacity (GB)	Total logical data bytes
20	20,576,747,520
40	41,174,138,880
60	61,492,838,400
80	82,348,277,760
100	102,935,347,200
120	123,522,416,640

Electromagnetic compatibility

When installed in a suitable enclosure and exercised with a random accessing routine at the maximum data rate the hard disk drive meets the following worldwide EMC requirements listed below:

- United States Federal Communications Commission (FCC) Rules and Regulations (Class B), Part 15.
- European Economic Community (EEC) directive number 76/889

related to the control of radio frequency interference and the Verband Deutscher Elektrotechniker (VDE) requirements of Germany (GOP).

CE Mark

Under the sole responsibility of Yamato Lab, IBM Japan Ltd or IBM United Kingdom Ltd, the drive is declared to be in conformity with the requirements of EC Council Directive 89/336/EEC on the approximation of laws of the Member States relating to electromagnetic compatibility.

C-Tick Mark

The drive complies with the following Australian EMC standard: *Limits and methods of measurement of radio disturbance characteristics of information technology equipment, AS/NZS 3548:1995 CLASS B.*

Environment

Operating conditions

Temperature	5 to 55°C ¹
Relative humidity (noncondensing)	8 to 90%RH
Maximum wet bulb temperature (noncondensing)	29.4°C
Maximum temperature gradient	15°C/hour
Altitude	-300 to 3048 m

¹The system is responsible for providing sufficient air movement to maintain a surface temperature below 60°C at the center of the top cover of the drive.

Non operating conditions

Temperature	-40 to 65°C
Relative humidity (noncondensing)	5 to 95%RH
Maximum wet bulb temperature (noncondensing)	35°C
Altitude	-300 to 12,000m

Operating shock

The drive meets IBM Standard C-S 1-9711-007 for the S5 product classification.

The drive meets the following criteria while operating in respective conditions described in the list below.

- No error occurs with a 10 G half-sine shock pulse of 11 ms duration in all models.

- No data loss occurs with a 30 G half-sine shock pulse of 4 ms duration in all models.
- No data loss occurs with a 55 G half-sine shock pulse of 2 ms duration in all models.

The shock test consists of ten shocks inputs in each axis and in each direction for a total of 60. There must be a delay between shock pulses that is long enough to allow the drive to complete all of the necessary error recovery procedure.

Nonoperating shock

The drives will operate with no degradation of performance after being subjected to a shock pulses with the following characteristics. The tests involved trapezoidal and sinusoidal shock wave.

Trapezoidal shock wave

- The approximate shape of the pulse is square (trapezoidal).
- Approximate rise and fall time of pulse = 1 ms.
- Average acceleration level = 50 G. (Average response curve value during the time following the 1 ms rise time and before the 1 ms fall with a time duration of 11 ms)
- Minimum velocity change equals 4.23 m/s.

Sinusoidal shock wave

The shape is approximately a half-sine pulse. The following table shows the maximum acceleration level and duration.

	Acceler- ation level (G)	Duration (ms)
All models	75	11
120 GB & 100 GB models	350	2
20 GB – 80 GB models	400	2

Rotational shock

No data loss is incurred with the following rotational shocks applied around the axis of the actuator pivot:

- 30,000 rad/s² for a duration of 1 ms
- 20,000 rad/s² for a duration of 2 ms

Acoustics

The upper limit criteria of the octave sound power levels are given in Bels relative to one pico watt and are shown below. The measurement method is in accordance with ISO7779.

- IC35L120AVVA07
- IC35L100AVVA07
- IC35L040AVVN07
- IC35L020AVVN07

Mode	Typical (Bel)	Max. (Bel)
Idle	3.1	3.4
Operating		
Performance seek mode	3.4	3.7
Quiet seek mode	3.2	3.5

- IC35L080AVVA07
- IC35L060AVVA07
- IC35L040AVVA07
- IC35L020AVVA07

Mode	Typical (Bel)	Max. (Bel)
Idle	3.0	3.4
Operating		
Performance seek mode	3.4	3.7
Quiet seek mode	3.1	3.5



ATTENTION: The drive must be protected against electrostatic discharge especially when being handled.

The safest way to avoid damage is to put the drive in an anti-static bag before ESD wrist straps are removed.

Drives must be shipped in approved containers. Severe damage can be caused to the drive if the packaging does not adequately protect against the shock levels induced when a box is dropped. Consult your IBM representative if you do not have an approved shipping container.

Command descriptions

The following commands are supported by the drive:

Commands	(Hex)	P
Check Power Mode	E5	3
Check Power Mode*	98	3
Execute Device Diagnostic	90	3
Flush Cache	E7	3
Format Track	50	2
Identify Device	EC	1
Idle	E3	3
Idle*	97	3
Idle Immediate	E1	3
Idle Immediate*	95	3
Initialize Device Parameters	91	3
NOP	00	3
Read Buffer	E4	1
Read DMA (retry)	C8	4
Read DMA (no retry)	C9	4
Read DMA Queued	C7	5
Read Long (retry)	22	1
Read long (no retry)	23	1
Read Multiple	C4	1
Read Native Max Address	F8	3
Read Sectors (retry)	20	1
Read Sectors (no retry)	21	1
Read Verify Sectors (retry)	40	3
Read Verify Sectors (no retry)	41	3
Recalibrate	1x	3
Security Disable Password	F6	2
Security Erase Prepare	F3	3
Security Erase Unit	F4	2
Security Freeze Lock	F5	3
Security Set Password	F1	2
Security Unlock	F2	2
Seek	7x	3
Service	A2	5
Set Features	EF	3
Set Max Address	F9	3
Set Multiple Mode	C6	3
Sleep	E6	3
Sleep*	99	3
SMART Disable Operations	B0	3
S.M.A.R.T. Enable/Disable Attribute Auto save	B0	3
S.M.A.R.T. Enable Operations	B0	3
S.M.A.R.T. Execute Off-line Data Collection	B0	3

S.M.A.R.T. Read Attribute Values	B0	1
S.M.A.R.T. Read Attribute Thresholds	B0	1
S.M.A.R.T. Return Status	B0	3
S.M.A.R.T. Save Attribute Values	B0	3
S.M.A.R.T. Read Log Sector	B0	1
S.M.A.R.T. Write Log Sector	B0	2
S.M.A.R.T. Enable/Disable Automatic Off-line Data Collection	B0	3
Standby	E2	3
Standby*	96	3
Standby Immediate	E0	3
Standby Immediate*	94	3
Write Buffer	E8	2
Write DMA (retry)	CA	4
Write DMA (no retry)	CB	4
Write DMA Queued	CC	5
Write Long (retry)	32	2
Write Long (no retry)	33	2
Write Multiple	C5	2
Write Sectors (retry)	30	2
Write Sectors (no retry)	31	2

Protocol

- 1 PIO data IN command
- 2 PIO data OUT command
- 3 Non data command
- 4 DMA command
- 5 DMA queued command
- + Vendor specific command

Note: Commands marked * are alternate command codes for previously defined commands

Signal definition

Pin	Signal	I/O	Type
01	RESET-	I	(2)
02	GND	-	-
03	DD7	I/O	(1)
04	DD8	I/O	(1)
05	DD6	I/O	(1)
06	DD9	I/O	(1)
07	DD5	I/O	(1)
08	DD10	I/O	(1)
09	DD4	I/O	(1)
10	DD11	I/O	(1)
11	DD3	I/O	(1)
12	DD12	I/O	(1)
13	DD2	I/O	(1)
14	DD13	I/O	(1)
15	DD1	I/O	(1)
16	DD14	I/O	(1)
17	DD0	I/O	(1)
18	DD15	I/O	(1)
19	GND	-	-
(20)	Key	-	-
21	DMARQ	O	(1)
22	GND	-	-
23	DIOW-(**)	I	(2)
24	GND	-	-
25	DIOR-(**)	I	(2)
26	GND	-	-
27	IORDY(**)	O	(1)
28	CSEL	I	(2)
29	DMACK-	I	(2)
30	GND	-	-
31	INTRQ	O	(1)
32	IOCS16-(***)	O	(3)
33	DA1	I	(2)
34	PDIAG-	I/O	(3)
35	DA0	I	(2)
36	DA2	I	(2)
37	CS0-	I	(2)
38	CS1-	I	(2)
39	DASP-	I/O	(3)
40	GND	-	-

Notes:

Type:

- (1) 3-state
- (2) TTL
- (3) open-collector or open drain output

(***) up to ATA-2

O – an output from the drive.

I - an input to the drive.

"I/O" designates an input/output common.

The signal lines marked with (**) are re-defined during the Ultra DMA protocol to provide special functions. These lines change from the conventional to special definitions at the moment the Host decides to allow a DMA burst if the Ultra DMA transfer mode was previously chosen by means of SetFeatures. The Drive becomes aware of this change upon assertion of the DMACK- line.

IBM storage products

These lines revert back to their original definitions upon the deassertion of DMACK– at the termination of the DMA burst. See the table below.

Ultra DMA definitions

	Special definition (for Ultra DMA)	Conventional definition
Write	DDMARDY–	IORDY
	HSTROBE	DIOR–
	STOP	DIOW–
Read	HDMARDY –	DIOR–
	DSTROBE	IORDY
	STOP	DIOW–

Mechanical data

Height	25.4 mm ± 0.4
Width	101.6 mm ± 0.4
Length	146.0 mm ± 0.6
<hr/>	
Weight (maximum)	640 grams

Mounting

The drive will operate in all axes (six directions). Performance and error rate will stay within specification limits if the drive is operated in the other permissible orientations from which it was formatted.

For reliable operation the drive must be mounted in the system securely enough to prevent damage from excessive motion or vibration during seek operation or spindle rotation, using appropriate screws or equivalent mounting hardware.

Drive level vibration test and shock test are to be conducted with the drive mounted to the table using the bottom four screws.

Mounting holes

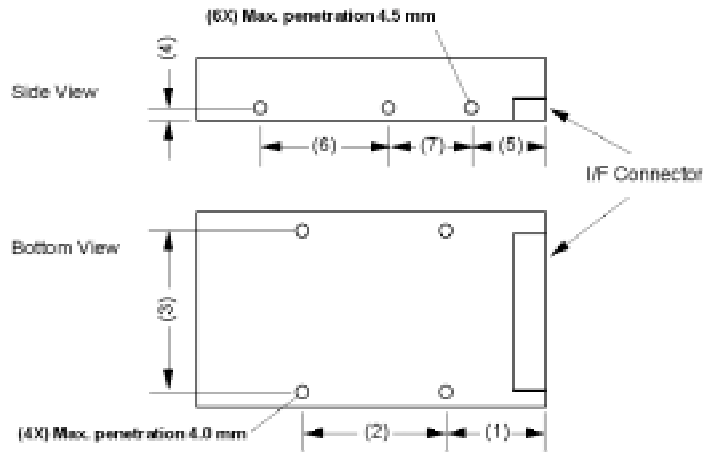

Dimension reference number	(1)	(2)	(3)	(4)	(5)	(6)	(7)
Dimension (mm)	41.28 ± 0.5	44.45 ± 0.2	95.25 ± 0.2	6.35 ± 0.2	28.5 ± 0.5	60.0 ± 0.2	41.6 ± 0.2

Mounting screw thread count = 6-32 UNC

Notes: Recommended screw torque to be applied to mounting screws is 0.6–1.0 Nm (6–10 kg-cm).

Mechanical dimensions

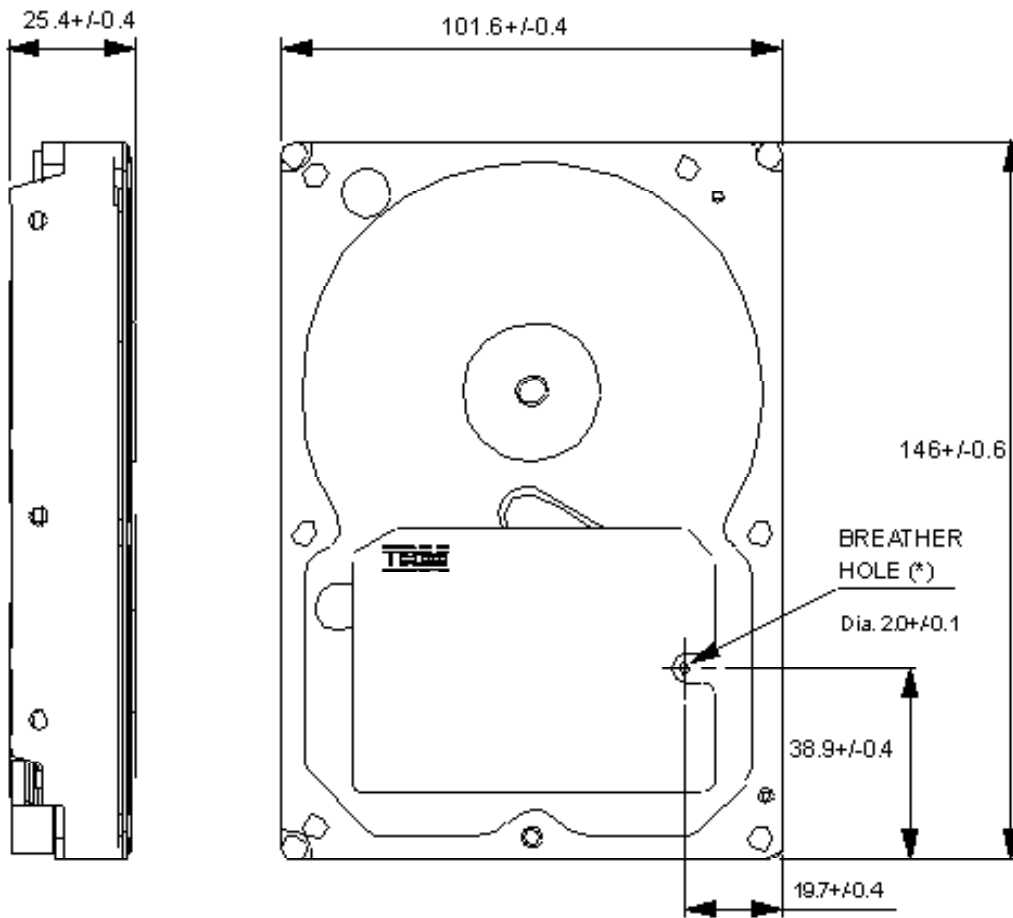

LEFT

FRONT

*** DO NOT BLOCK THE BREATHER HOLE.**



© International Business Machines Corporation 2002

www.ibm.com/harddrive

IBM Technology Group Support Center

Telephone: 888.426.5214 or 507.286.5825

E-mail: drive@us.ibm.com

Singapore Technology Group Support Center

Telephone: (65)6418.9595 or 1800.418.9595

E-mail: drive@sg.ibm.com

UK Technology Group Support Center

Telephone: 44.1475.898.125

E-mail: drive@uk.ibm.com

Germany Technology Group Support Center

Telephone: 49.7032.153050

E-mail: drive@de.ibm.com

IBM Systems Storage Division

5600 Cottle Road

San Jose CA 95193

www.ibm.com/storage

Printed in the United States of America

06-2002

All Rights Reserved

IBM is the registered trademark and Deskstar is the trademark of International Business Machines Corporation.

AMP is a trademark of AMP Incorporated.

Other company, product, and service names may be trademarks or service marks of others.

Produced by the IBM Technology Group Support Center.

Deskstar 120GXP Hard disk drive specifications, Revision 4.1, and Addendum to Deskstar 120GXP Hard disk drive specifications, Revision 1.0

This product summary is not a substitute for the full production specification, which should be used when detailed information is required.

Product Description data represents IBM's design objectives and is provided for comparative purposes; actual results may vary based on a variety of factors. This product data does not constitute a warranty. Questions regarding IBM warranty terms or methodology used to derive this data should be referred to the IBM Technology Group Support Center.

Data subject to change without notice.

References in this publication to IBM products, programs, or services do not imply that IBM intends to make them available in all countries in which IBM operates.

Date: 18 June 2002©