



Hard disk drive specifications Travelstar 60GH & 40GN

2.5 inch ATA/IDE hard disk drive

Enhanced Availability model



Models: IC25T060ATCX05
IC25N040ATCX04
IC25N030ATCX04
IC25N020ATCX04
IC25N010ATCX04

Revision 1.1

29 May 2002



Hard disk drive specifications

Travelstar 60GH & 40GN

2.5 inch ATA/IDE hard disk drive

Enhanced Availability model



Models: IC25T060ATCX05
IC25N040ATCX04
IC25N030ATCX04
IC25N020ATCX04
IC25N010ATCX04

Revision 1.1

29 May 2002

1st Edition (Revision 0.1) S07N-7715-01 (11 January 2002) Preliminary

2nd Edition (Revision 1.0) S07N-7715-02 (22 January 2002)

3rd Edition (Revision 1.1) S07N-7715-03 (29 May 2002)

The following paragraph does not apply to the United Kingdom or any country where such provisions are inconsistent with local law: INTERNATIONAL BUSINESS MACHINES CORPORATION PROVIDES THIS PUBLICATION "AS IS" WITHOUT WARRANTY OF ANY KIND, EITHER EXPRESS OR IMPLIED, INCLUDING, BUT NOT LIMITED TO, THE IMPLIED WARRANTIES OF MERCHANTABILITY OR FITNESS FOR A PARTICULAR PURPOSE. Some states do not allow disclaimer or express or implied warranties in certain transactions, therefore, this statement may not apply to you.

This publication could include technical inaccuracies or typographical errors. Changes are periodically made to the information herein; these changes will be incorporated in new editions of the publication. IBM may make improvements and changes in any product or program described in this publication at any time.

It is possible that this publication may contain reference to, or information about, IBM products (machines and programs), programming, or services that are not announced in your country. Such references or information must not be construed to mean that IBM intends to announce such IBM products, programming, or services in your country.

Technical information about this product is available by contacting the local IBM representative or by using the following:

Internet: <http://www.ibm.com/harddrive>

IBM may have patents or pending patent applications covering subject matter in this document. The furnishing of this document does not give you any license to these patents. You can send license inquiries, in writing, to the IBM Director of Commercial Relations, IBM Corporation, Armonk, NY 10577.

© Copyright International Business Machines Corporation 2002. All rights reserved.

Note to US Government Users—Documentation related to restricted rights—Use, duplication or disclosure is subject to restrictions set forth in GSA ADP Schedule Contract with IBM Corp.

Table of contents

Figures	vii
1.0 General	1
1.1 Abbreviations	1
1.2 References	3
1.3 General caution	3
1.4 Drive handling precautions	3
2.0 General features	5
Part 1. Functional specification	7
3.0 Fixed disk subsystem description	9
3.1 Control Electronics	9
3.2 Head disk assembly data	9
4.0 Fixed disk characteristics	11
4.1 Formatted capacity by model number	11
4.2 Data sheet	12
4.3 Cylinder allocation by model number	12
4.4 Performance characteristics	14
4.4.1 Command overhead	14
4.4.2 Mechanical positioning	15
4.4.3 Operating modes	17
5.0 Data integrity	19
5.1 Data loss on power off	19
5.2 Write Cache	19
5.3 Equipment status	19
5.4 WRITE safety	20
5.5 Data buffer test	20
5.6 Error recovery	20
5.7 Automatic reallocation	20
5.7.1 Nonrecovered write errors	20
5.7.2 Nonrecoverable read error	20
5.7.3 Recovered read errors	20
5.8 ECC	21
6.0 Specification	23
6.1 Environment	23
6.1.1 Temperature, humidity, and altitude	23
6.1.2 Radiation noise	24
6.1.3 Conductive noise	24
6.1.4 Magnetic fields	24
6.2 DC power requirements	25
6.2.1 Power consumption efficiency	26
6.3 Start up Current	26
6.4 Reliability	28
6.4.1 Data reliability	28
6.4.2 Failure prediction (S.M.A.R.T.)	28
6.4.3 Cable noise interference	28
6.4.4 Service life and usage condition	28

6.4.5 Preventive maintenance	29
6.4.6 Load/unload	29
6.5 Mechanical specifications	31
6.5.1 Physical dimensions and weight	31
6.5.2 Mounting hole locations	31
6.5.3 Connector and jumper description	32
6.5.4 Mounting orientation	32
6.5.5 Load/unload mechanism	33
6.6 Vibration and shock	34
6.6.1 Operating vibration	34
6.6.2 Nonoperating vibration	35
6.6.3 Operating shock	35
6.6.4 Nonoperating shock	36
6.7 Acoustics	37
6.7.1 Sound power level	37
6.7.2 Discrete tone penalty	38
6.8 Identification labels	39
6.9 Electromagnetic compatibility	39
6.9.1 CE Mark	39
6.9.2 C-Tick Mark	39
6.10 Safety	40
6.10.1 UL and CSA approval	40
6.10.2 IEC compliance	40
6.10.3 German Safety Mark	40
6.10.4 Flammability	40
6.10.5 Secondary circuit protection	40
6.11 Packaging	40
7.0 Electrical interface specifications	41
7.1 Cabling	41
7.2 Interface connector	41
7.3 Signal definitions	42
7.4 Signal descriptions	44
7.5 Interface logic signal levels	47
7.6 Reset timings	47
7.7 PIO timings	48
7.8 Multiword DMA timings	49
7.9 Ultra DMA timings	50
7.9.1 Initiating Read DMA	50
7.9.2 Host Pausing Read DMA	51
7.9.3 Host Terminating Read DMA	52
7.9.4 Device Terminating Read DMA	53
7.9.5 Initiating Write DMA	54
7.9.6 Device Pausing Write DMA	55
7.9.7 Device Terminating Write DMA	56
7.9.8 Host Terminating Write DMA	57
7.10 Drive address setting	58
7.10.1 Drive default address setting	58
7.11 Addressing of HDD registers	59
Part 2. Interface specification	61
8.0 General	63
8.1 Introduction	63

8.2 Terminology	63
9.0 Deviations from standard	65
10.0 Registers	67
10.1 Alternate Status Register	68
10.2 Command Register	68
10.3 Cylinder High Register	68
10.4 Cylinder Low Register	68
10.5 Data Register	69
10.6 Device Control Register	69
10.7 Drive Address Register	70
10.8 Device/Head Register	70
10.9 Error Register	71
10.10 Features Register	71
10.11 Sector Count Register	71
10.12 Sector Number Register	72
10.13 Status Register	72
11.0 General operation descriptions	73
11.1 Reset response	73
11.2 Register initialization	75
11.3 Diagnostic and Reset considerations	76
11.4 Power-off considerations	77
11.4.1 Load/Unload	77
11.4.2 Emergency unload	77
11.4.3 Required power-off sequence	78
11.5 Sector Addressing Mode	78
11.5.1 Logical CHS addressing mode	78
11.5.2 LBA addressing mode	79
11.6 Power management features	80
11.6.1 Power Mode	80
11.6.2 Power management commands	80
11.6.3 Standby/Sleep command completion timing	80
11.6.4 Standby timer	81
11.6.5 Status	81
11.6.6 Interface Capability for Power Modes	81
11.6.7 Initial Power Mode at Power On	81
11.7 S.M.A.R.T. Function	82
11.7.1 Attributes	82
11.7.2 Attribute values	82
11.7.3 Attribute thresholds	82
11.7.4 Threshold exceeded condition	82
11.7.5 S.M.A.R.T. commands	82
11.7.6 S.M.A.R.T. operation with power management modes	83
11.8 Security Mode Feature Set	84
11.8.1 Security Mode	84
11.8.2 Security level	84
11.8.3 Password	84
11.8.4 Master Password Revision Code	85
11.8.5 Operation example	85
11.8.6 Command table	88
11.9 Protected Area Function	90
11.9.1 Example for operation (In LBA Mode)	90
11.9.2 Set Max security extension commands	91
11.10 Address Offset Feature (vendor specific)	93
11.10.1 Enable/Disable Address Offset Mode	93

11.10.2 Identify Device Data	94
11.10.3 Exceptions in Address Offset Mode	94
11.11 Seek Overlap	95
11.12 Write Cache function	96
11.13 Delayed Write function (vendor specific)	96
11.13.1 Enable/Disable Delayed Write command	96
11.14 Reassign Function	97
11.14.1 Auto Reassign Function	97
12.0 Command protocol	99
12.1 Data In commands	99
12.2 Data Out commands	101
12.3 Nondata commands	103
12.4 DMA Data Transfer commands	104
13.0 Command descriptions	105
13.1 Check Power Mode (E5h/98h)	109
13.2 Device Configuration Overlay (B1h)	110
13.2.1 DEVICE CONFIGURATION RESTORE (subcommand C0h)	110
13.2.2 DEVICE CONFIGURATION FREEZE LOCK (subcommand C1h)	111
13.2.3 DEVICE CONFIGURATION IDENTIFY (subcommand C2h)	111
13.2.4 DEVICE CONFIGURATION SET (subcommand C3h)	111
13.3 Enable/Disable Delayed Write (FAh: vendor specific)	114
13.4 Execute Device Diagnostic (90h)	115
13.5 Flush Cache (E7h)	116
13.6 Format Track (50h: vendor specific)	117
13.7 Format Unit (F7h: vendor specific)	118
13.8 Identify Device (ECh)	120
13.9 Idle (E3h/97h)	129
13.10 Idle Immediate (E1h/95h)	130
13.11 Initialize Device Parameters (91h)	131
13.12 Read Buffer (E4h)	132
13.13 Read DMA (C8h/C9h)	133
13.14 Read Long (22h/23h)	135
13.15 Read Multiple (C4h)	137
13.16 Read Native Max ADDRESS (F8h)	139
13.17 Read Sectors (20h/21h)	141
13.18 Read Verify Sectors (40h/41h)	143
13.19 Recalibrate (1xh)	145
13.20 Security Disable Password (F6h)	146
13.21 Security Erase Prepare (F3h)	147
13.22 Security Erase Unit (F4h)	148
13.23 Security Freeze Lock (F5h)	150
13.24 Security Set Password (F1h)	151
13.25 Security Unlock (F2h)	153
13.26 Seek (7xh)	155
13.27 Sense Condition (F0h: vendor specific)	156
13.28 Set Features (EFh)	157
13.29 Set Max ADDRESS (F9h)	159
13.30 Set Multiple (C6h)	161
13.31 Sleep (E6h/99h)	162
13.32 S.M.A.R.T. Function Set (B0h)	163
13.32.1 S.M.A.R.T. Function Subcommands	164
13.32.2 Device Attributes Data Structure	168
13.32.3 Device Attribute Thresholds data structure	173
13.32.4 S.M.A.R.T. error log sector	175

13.32.5 Self-test log data structure	178
13.32.6 Error reporting	179
13.33 Standby (E2h/96h)	180
13.34 Standby Immediate (E0h/94h)	181
13.35 Write Buffer (E8h)	182
13.36 Write DMA (CAh/CBh)	183
13.37 Write Long (32h/33h)	185
13.38 Write Multiple (C5h)	187
13.39 Write Sectors (30h/31h)	189
13.40 Write Verify (3Ch: vendor specific)	191
14.0 Time-out values	193
15.0 Appendix	195
15.1 Commands Support Coverage	195
15.2 SET FEATURES Command Support Coverage	197
15.3 Changes from Travelstar 48GH, 30GN & 15GN	198
Index	199

This page intentionally left blank.

Figures

Figure 1. Handling Precaution 1	3
Figure 2. Handling Precaution 2	3
Figure 3. Formatted capacity by model number.	11
Figure 4. Data sheet	12
Figure 5. Cylinder allocation of 60 GB model	12
Figure 6. Cylinder allocation — all models except 60 GB (high TPI format)	13
Figure 7. Cylinder allocation — all models except 60 GB (low TPI format)	13
Figure 8. Performance characteristics	14
Figure 9. Mechanical positioning performance	15
Figure 10. Full stroke seek time	15
Figure 11. Single track seek time	16
Figure 12. Latency time	16
Figure 13. Drive ready time	16
Figure 14. Operating mode	17
Figure 15. Drive ready time	17
Figure 16. Examples of error cases.	21
Figure 17. Environmental condition	23
Figure 18. Limits of temperature and humidity	23
Figure 19. Magnetic flux density limits	24
Figure 20. DC Power requirements	25
Figure 21. Power consumption efficiency	26
Figure 22. Typical current wave form at start up of 60 GB model	26
Figure 23. Typical current wave form at start up of 40 GB model	27
Figure 24. Typical current wave form at start up of 20 GB model)	27
Figure 25. Physical dimensions and weight	31
Figure 26. Mounting hole locations of the 60 GB model.	31
Figure 27. Mounting hole locations of all models except 60 GB model.	32
Figure 28. Random vibration PSD profile breakpoints (operating)	34
Figure 29. Swept sine vibration	34
Figure 30. Random Vibration PSD Profile Breakpoints (nonoperating)	35
Figure 31. Operating shock	35
Figure 32. Nonoperating shock	36
Figure 33. Weighted sound power	37
Figure 34. Interface connector pin assignments	41
Figure 35. Signal definition	42
Figure 36. Special signal definitions for Ultra DMA	43
Figure 37. System reset timings	47
Figure 38. PIO cycle timings	48
Figure 39. Multiword DMA cycle timings	49
Figure 40. Ultra DMA cycle timings (Initiating Read)	50
Figure 41. Ultra DMA cycle timings (Host Pausing Read)	51
Figure 42. Ultra DMA cycle timings (Host Terminating Read)	52
Figure 43. Ultra DMA cycle timings (Device Terminating Read)	53
Figure 44. Ultra DMA cycle timings (Initiating Write)	54
Figure 45. Ultra DMA cycle timings (Device Pausing Write)	55
Figure 46. Ultra DMA cycle timings (Device Terminating Write)	56
Figure 47. Ultra DMA cycle timings (Host Terminating Write)	57
Figure 48. Drive address setting	58
Figure 49. I/O address map	59

Figure 50. Register Set	67
Figure 51. Alternate Status Register	68
Figure 52. Device Control Register	69
Figure 53. Drive Address Register	70
Figure 54. Device/Head Register	70
Figure 55. Error Register	71
Figure 56. Status Register	72
Figure 57. Reset response table	74
Figure 58. Default Register Values	75
Figure 59. Diagnostic Codes	75
Figure 60. Reset error register values	76
Figure 61. Device behavior by ATA commands.	77
Figure 62. Power conditions	81
Figure 63. Initial setting	85
Figure 64. Usual operation for POR	86
Figure 65. Password lost	87
Figure 66. Command table for device lock operation (1 of 2)	88
Figure 67. Command table for device lock operation (2 of 2)	89
Figure 68. Set Max SET PASSWORD data content	91
Figure 69. Set Max security mode transition	92
Figure 70. Device address map before and after Set Feature	93
Figure 71. Seek overlap	95
Figure 72. Command set (1 of 2)	105
Figure 73. Command set (2 of 2)	106
Figure 74. Command Set (Subcommand)	107
Figure 75. Check Power Mode command (E5h/98h)	109
Figure 76. Check Power Mode Command (E5h/98h)	110
Figure 77. Device Configuration Overlay Features register values	110
Figure 78. Device Configuration Overlay Data structure	112
Figure 79. DCO error information definition	113
Figure 80. Enable/Disable Delayed Write command (FAh)	114
Figure 81. Execute Device Diagnostic command (90h)	115
Figure 82. Flush Cache command (E7h)	116
Figure 83. Format Track command (50h)	117
Figure 84. Format Unit command (F7h)	118
Figure 85. Identify Device command (ECh)	120
Figure 86. Identify device information. (Part 1 of 7)	121
Figure 87. Identify device information. (Part 2 of 7)	122
Figure 88. Identify device information. (Part 3 of 7)	123
Figure 89. Identify device information. (Part 4 of 7)	124
Figure 90. Identify device information. (Part 5 of 7)	125
Figure 91. Identify device information. (Part 6 of 7)	126
Figure 92. Identify device information. (Part 7 of 7)	127
Figure 93. Number of cylinders/heads/sectors by model.	128
Figure 94. Idle command (E3h/97h)	129
Figure 95. Idle Immediate command (E1h/95h)	130
Figure 96. Initialize Device Parameters command (91h)	131
Figure 97. Read Buffer command (E4h)	132
Figure 98. Read DMA command (C8h/C9h)	133
Figure 99. Read Long command (22h/23h)	135
Figure 100. Read Multiple command (C4h)	137
Figure 101. Read Native Max ADDRESS (F8h)	139
Figure 102. Read Sectors command (20h/21h)	141
Figure 103. Read Verify Sectors command (40h/41h)	143

Figure 104. Recalibrate command (1xh)	145
Figure 105. Security Disable Password command (F6h)	146
Figure 106. Password Information for Security Disable Password command	146
Figure 107. Security Erase Prepare command (F3h)	147
Figure 108. Security Erase Unit command (F4h)	148
Figure 109. Erase Unit information	148
Figure 110. Security Freeze Lock command (F5h)	150
Figure 111. Security Set Password command (F1h)	151
Figure 112. Security Set Password information	152
Figure 113. Security Unlock command (F2h)	153
Figure 114. Security Unlock information	154
Figure 115. Seek command (7xh)	155
Figure 116. Sense Condition Command (F0h)	156
Figure 117. Set Features command (EFh)	157
Figure 118. Set Max ADDRESS (F9h)	159
Figure 119. Set Multiple command (C6h)	161
Figure 120. Sleep command (E6h/99h)	162
Figure 121. S.M.A.R.T. Function Set command (B0h)	163
Figure 122. Log sector addresses	165
Figure 123. Device Attribute Data Structure	168
Figure 124. Individual Attribute Data Structure	169
Figure 125. Status Flag definitions	170
Figure 126. Device Attribute Thresholds Data Structure	173
Figure 127. Individual Threshold Data Structure	174
Figure 128. S.M.A.R.T. error log sector	175
Figure 129. Error log data structure	175
Figure 130. Command data structure	176
Figure 131. Error data structure	177
Figure 132. Self-test log data structure	178
Figure 133. S.M.A.R.T. Error Codes	179
Figure 134. Standby command (E2h/96h)	180
Figure 135. Standby Immediate command (E0h/94h)	181
Figure 136. Write Buffer command (E8h)	182
Figure 137. Write DMA command (CAh/CBh)	183
Figure 138. Write Long command (32h/33h)	185
Figure 139. Write Multiple command (C5h)	187
Figure 140. Write Sectors command (30h/31h)	189
Figure 141. Time-out values	193
Figure 142. Command coverage (1 of 2)	195
Figure 143. Command coverage (2 of 2)	196
Figure 144. SET FEATURES command coverage	197

This page intentionally left blank.

1.0 General

This document describes the specifications of the enhanced availability model of IBM Travelstar 60GH & 40GN, a 2.5 type hard disk drive with ATA/IDE interface:

Drive name	Model Number	Capacity (GB)	Height (mm)	Rotation speed (rpm)
Travelstar 60GH	IC25T060ATCX05	60	12.5	5,400
Travelstar 40GN	IC25N040ATCX04	40	9.5	4,200
Travelstar 40GN	IC25N030ATCX04	30	9.5	4,200
Travelstar 40GN	IC25N020ATCX04	20	9.5	4,200
Travelstar 40GN	IC25N010ATCX04	10	9.5	4,200

Part 1 of this document beginning on page 7 defines the hardware functional specification. Part 2 of this document beginning on page 61 defines the interface specification

These specifications are subject to change without notice.

1.1 Abbreviations

Abbreviation	Meaning
32 KB	32 x 1024 bytes
64 KB	64 x 1024 bytes
A	Ampere
AC	alternating current
AT	Advanced Technology
ATA	Advanced Technology Attachment
Bels	unit of sound power
BIOS	Basic Input/Output System
°C	degrees Celsius
CSA	Canadian Standards Association
C-UL	Canadian-Underwriters Laboratory
Cyl	cylinder
DC	direct current
DFT	Drive Fitness Test
DMA	Direct Memory Access
ECC	error correction code
EEC	European Economic Community
EMC	electromagnetic compatibility
ERP	Error Recovery Procedure
ESD	electrostatic discharge
FCC	Federal Communications Commission
FRU	field replacement unit
G	gravity, a unit of force
G²/Hz	(32 ft/sec) ² per Hertz
Gb	1,000,000,000 bits
Gb/sq.in	1,000,000,000 bits per square inch
GB	1,000,000,000 bytes
GND	ground
h	hexadecimal
HDD	hard disk drive
Hz	hertz

I	Input
ILS	integrated lead suspension
imped	impedance
I/O	Input/Output
ISO	International Standards Organization
KB	1,000 bytes
Kbpi	1000 bits per mm
kgf-cm	kilogram (force)-centimeter
KHz	kilohertz
LBA	logical block addressing
Lw	unit of A-weighted sound power
m	meter
max. or Max.	maximum
MB	1,000,000 bytes
Mbps	1,000,000 Bit per second
Mb/sec	1,000,000 Bit per second
MB/sec	1,000,000 bytes per second
Mb/sq.in	1,000,000 bits per square inch
MHz	megahertz
MLC	Machine Level Control
mm	millimeter
ms	millisecond
us, μs	microsecond
No. or #	number
oct/min	oscillations per minute
O	Output
OD	Open Drain Programmed Input/Output
PIO	
POH	power on hours
Pop.	population
P/N	part number
p-p	peak-to-peak
PSD	power spectral density
RES	radiated electromagnetic susceptibility
RFI	radio frequency interference
RH	relative humidity
% RH	per cent relative humidity
RMS	root mean square
RPM	revolutions per minute
RST	reset
R/W	read/write
sec	second
Sect/Trk	sectors per track
SELV	secondary low voltage
S.M.A.R.T	Self-monitoring, analysis, and reporting technology
TPI	tracks per inch
Trk	track
TTL	transistor-transistor logic
UL	Underwriters Laboratory
V	volt
VDE	Verband Deutscher Electrotechniker
W	watt
3-state	transistor-transistor tristate logic

1.2 References

ATA/ATAPI-5 (T13/1321D Revision 3)

1.3 General caution

- Do not apply force to the top cover (See figure below).
 - Do not cover the breathing hole on the top cover (See figure below).
 - Do not touch the interface connector pins or the surface of the printed circuit board.
 - The drive can be damaged by shock or ESD (Electric Static Discharge). Any damages incurred to the drive after removing it from the shipping package and the ESD protective bag are the responsibility of the user
-

1.4 Drive handling precautions

Do not press!

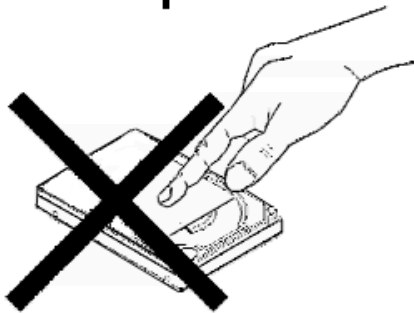

Do not press on the drive cover during handling.

Figure 1. Handling Precaution 1

Do not cover this hole

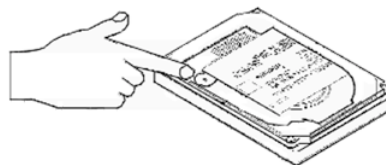

Covering this hole will result in loss of data

Figure 2. Handling Precaution 2

This page intentionally left blank.

2.0 General features

- 2.5 inch, 12.5- and 9.5-mm Height MCC Compliance
- Formatted capacities of 60 GB, 40 GB, 30 GB, 20 GB, and 10 GB
- 512 bytes/sector
- AT Interface (Enhanced IDE) conforming to ATA/ATAPI-5
- Integrated controller
- No-ID recording format
- Coding : 96/104 MTR
- Multi zone recording
- Enhanced ECC On-The-Fly
 - ◆ 40 bytes 3 way Interleaved Reed Solomon Code
 - ◆ 5 bytes per interleave On-The-Fly correction
- Segmented Buffer with write cache
 - ◆ 2 MB - Upper 280 KB is used for firmware
- Fast data transfer rate (up to 100 MB/s)
- Media data transfer rate (max):
 - ◆ 60-GB model - 261 Mb/s
 - ◆ all other models - 245 Mb/s
- Average seek time: 12 ms for read
- Closed-loop actuator servo (Embedded Sector Servo)
- Rotary voice coil motor actuator
- Load/Unload mechanism
- Mechanical latch
- **Enhanced availability feature**
 - ◆ 732 POH monthly with continuous operation
 - ◆ Ambient temperature; 5 to 40°C
- Power on to ready
 - ◆ 60-GB model - 5.0 sec
 - ◆ all other models - 3.0 sec
- Operating shock
 - ◆ 60-GB model - 150 G/2ms
 - ◆ all other models - 200 G/2ms
- Nonoperating shock
 - ◆ 60-GB model - 700 G/1ms
 - ◆ all other models - 800 G/1ms

This page intentionally left blank.

Part 1. Functional specification

This page intentionally left blank.

3.0 Fixed disk subsystem description

3.1 Control Electronics

The control electronics works with the following functions:

- AT Interface Protocol
- Embedded Sector Servo
- No-ID (TM) formatting
- Multizone recording
- Code: 96/104 MTR
- ECC On-The-Fly

3.2 Head disk assembly data

The following technologies are used in the drive:

- Pico Slider
- Smooth glass disk
- GMR head
- Integrated lead suspension (ILS)
- Load/unload mechanism
- Mechanical latch

This page intentionally left blank.

4.0 Fixed disk characteristics

4.1 Formatted capacity by model number

Description	IC25T060ATCX05	IC25N040ATCX04	IC25N030ATCX04
Physical Layout			
Bytes per Sector	512	512	512
Sectors per Track			
low TPI format	307–556	360–672	360–672
high TPI format		336–648	336–648
Number of Heads	8	4	3
Number of Disks	4	2	2
Logical Layout			
Number of Heads	16	16	16
Number of Sectors/ Track	63	63	63
Number of Cylinders	16,383	16,383	16,383
Number of Sectors	117,210,240	78,140,160	58,605,120
Total Logical Data Bytes	60,011,642,880	40,007,761,920	30,005,821,440

Description	IC25N020ATCX04	IC25N010ATCX04
Physical Layout		
Bytes per Sector	512	512
Sectors per Track		
low TPI format	360–672	360–672
high TPI format	336–648	336–648
Number of Heads	2	1
Number of Disks	1	1
Logical Layout		
Number of Heads	16	16
Number of Sectors/ Track	63	63
Number of Cylinders	16,383	16,383
Number of Sectors	39,070,080	19,640,880
Total Logical Data Bytes	20,003,880,960	10,056,130,560

Figure 3. Formatted capacity by model number.

4.2 Data sheet

Data	60 GB model	All other models
Rotational Speed (RPM)	5,400	4,200
Data transfer rates (buffer to/from media) (Mbps)	146–262	130–245 125–241
Data transfer rates (Mbyte/sec) ULTRA DMA 100	100	100
Recording density (Kbpi) (Max)	459	528 509
Track density (Ktpi)	60.4	63.5 66.4
Areal density (Gb/sq.in.- Max)	28	34
Number of zones	16	16

Figure 4. Data sheet

4.3 Cylinder allocation by model number

Zone	60 GB model	
	Cylinder	No. of Sectors/Trk
0	0–1023	556
1	1024–2047	544
2	2048–4607	528
3	4608–6911	512
4	6912–9215	499
5	9216–13055	480
6	13056–15615	460
7	15616–17407	448
8	17408–20223	432
9	20224–22271	416
10	22272–24319	403
11	24320–27391	384
12	27392–29183	364
13	29184–30975	352
14	30976–33535	336
15	33536–35071	307

Figure 5. Cylinder allocation of 60 GB model

All other models - high TPI format		
Zone	Cylinder	No. of Sectors/Trk
0	0-511	648
1	512-2559	640
2	2560-4863	624
3	4864-9215	600
4	9216-11519	576
5	11520-13823	560
6	13824-16895	540
7	16896-19967	520
8	19968-21503	504
9	21504-24831	480
10	24832-27135	450
11	27136-28671	440
12	28672-31231	420
13	31232-33791	400
14	33792-37631	360
15	37632-39935	336

Figure 6. Cylinder allocation — all models except 60 GB (high TPI format)

All other models - low TPI format		
Zone	Cylinder	No. of Sectors/Trk
0	0-767	672
1	768-3327	660
2	3328-6655	640
3	6656-8703	624
4	8704-12287	600
5	12288-15359	576
6	15360-17151	560
7	17152-19967	540
8	19968-22015	520
9	22016-23295	504
10	23296-25343	480
11	25344-26879	480
12	26880-28159	450
13	28160-31743	420
14	31744-35327	384
15	35328-38143	360

Figure 7. Cylinder allocation — all models except 60 GB (low TPI format)

4.4 Performance characteristics

Drive performance is characterized by the following parameters:

- Command Overhead
- Mechanical Positioning
 - ◆ Seek Time
 - ◆ Latency
- Data Transfer Speed
- Buffering Operation (Look ahead/Write Cache)

Note: All the above parameters contribute to drive performance. There are other parameters which contribute to the performance of the actual system. This specification defines the essential characteristics of the drive. This specification does not include the system throughput as this is dependent upon the system and the application.

The following table gives a typical value for each parameter. The detailed descriptions are found in Section 5.0.

Function	60-GB	All other models
Average Random Seek Time - Read (ms)	12	12
Average Random Seek Time - Write (ms)	14	14
Rotational Speed (RPM)	5400	4200
Power-on-to-ready (sec)	5.0	3.0
Command overhead (ms)	1.0	1.0
Disk-buffer data transfer (Mb/s)	146–261	130–245 125–241
Buffer-host data transfer (MB/s)	100	100

Figure 8. Performance characteristics

4.4.1 Command overhead

Command overhead time is defined as the interval from the time that a drive receives a command to the time that the actuator starts its motion.

4.4.2 Mechanical positioning

4.4.2.1 Average seek time (including settling)

Command Type	Typical (ms)	Max. (ms)
Read	12	16
Write	14	17

Figure 9. Mechanical positioning performance

Typical and Max. are defined throughout the performance specification as follows:

Typical Average of the drive population tested at nominal environmental and voltage conditions.

Max. Maximum value measured on any one drive over the full range of the environmental and voltage conditions. (See section 6.1, "Environment" on page 23 and section 6.2, "DC power requirements" on page 25)

The seek time is measured from the start of motion of the actuator to the start of a reliable read or write operation. A reliable read or write operation implies that error correction/recovery is not employed to correct arrival problems. The Average Seek Time is measured as the weighted average of all possible seek combinations.

$$\sum_{n=1}^{\text{max.}} (\text{max.} + 1 - n)(T_{n_{\text{in}}} + T_{n_{\text{out}}})$$

$$\text{Weighted Average} = \frac{\sum_{n=1}^{\text{max.}} (\text{max.} + 1 - n)(T_{n_{\text{in}}} + T_{n_{\text{out}}})}{(\text{max.} + 1)(\text{max.})}$$

Where: max. = maximum seek length

n = seek length (1-to-max.)

T_{n_{in}} = inward measured seek time for an n-track seek

T_{n_{out}} = outward measured seek time for an n-track seek

4.4.2.2 Full stroke seek

Command Type	Typical (ms)	Max. (ms)
Read	23.0	30.0
Write	24.0	31.0

Figure 10. Full stroke seek time

Full stroke seek time in milliseconds is the average time of 1000 full stroke seeks.

4.4.2.3 Single track seek time (without command overhead, including settling)

Command Type	Typical (ms)	Maximum (ms)
Read	2.5	4.0
Write	3.0	4.5

Figure 11. Single track seek time

Single track seek is measured as the average of one (1) single track seek from every track in both directions (inward and outward).

4.4.2.4 Average latency

Models	Rotational Speed (RPM)	Time for one revolution (ms)	Average Latency (ms)
60 GB	5400	11.1	5.5
All others	4200	14.3	7.1

Figure 12. Latency time

4.4.2.5 Drive ready time

Condition	Model	Typical (sec)	Max. (sec)
Power On To Ready	60 GB model	5.0	9.5
Power On To Ready	All other models	3.0	9.5

Figure 13. Drive ready time

Ready The condition in which the drive is able to perform a media access command (for example—read, write) immediately.

Power On To Ready This includes the time required for the internal self diagnostics.

4.4.3 Operating modes

Operating mode	Description
Spin-Up	Start up time period from spindle stop or power down.
Seek	Seek operation mode
Write	Write operation mode
Read	Read operation mode
Performance idle	The device is capable of responding immediately to idle media access requests. All electronic components remain powered and the full frequency servo remains operational.
Active idle	Not applicable
Low power idle	Not applicable
Standby	The device interface is capable of accepting commands. The spindle motor is stopped. All circuitry but the host interface is in power saving mode. The execution of commands is delayed until the spindle becomes ready.
Sleep	The device requires a soft reset or a hard reset to be activated. All electronics, including spindle motor and host interface, are shut off.

Figure 14. Operating mode

4.4.3.1 Mode transition time

Models	From	To	Transition Time (typ)	Transition Time (max.)
60 GB	Standby	Idle	4.5	9.5
40 GB, 30 GB	Standby	Idle	2.0	9.5
20 GB, 10 GB	Standby	Idle	1.8	9.5

Figure 15. Drive ready time

4.4.3.2 Operating mode at power on

The device goes into Idle mode after power on or hard reset as an initial state. Initial state may be changed to Standby mode using pin C on the interface connector. Refer to section 7.10 on page 58, "Drive address setting" for details.

This page intentionally left blank.

5.0 Data integrity

5.1 Data loss on power off

- Data loss will not be caused by a power off during any operation except the write operation.
- A power off during a write operation causes the loss of any received or resident data that has not been written onto the disk media.
- A power off during a write operation might make a maximum of one sector of data unreadable. This state can be recovered by a rewrite operation.

5.2 Write Cache

When the write cache is enabled, the write command may complete before the actual disk write operation finishes. This means that a power off, even after the write command completion, could cause the loss of data that the drive has received but not yet written onto the disk.

In order to prevent this data loss, confirm the completion of the actual write operation prior to the power off by issuing a

- Soft reset
- Hard reset
- Flush Cache command
- Standby command
- Standby Immediate command
- Sleep command

Confirm the command's completion.

5.3 Equipment status

The equipment status is available to the host system any time the drive is not ready to read, write, or seek. This status normally exists at the power-on time and will be maintained until the following conditions are satisfied:

- The access recalibration/tuning is complete.
- The spindle speed meets the requirements for reliable operation.
- The self-check of the drive is complete.

The appropriate error status is made available to the host system if any of the following conditions occur after the drive has become ready:

- The spindle speed lies outside the requirements for reliable operation.
- The occurrence of a Write Fault condition.

5.4 WRITE safety

The drive ensures that the data is written into the disk media properly. The following conditions are monitored during a write operation. When one of these conditions exceeds the criteria, the write operation is terminated and the automatic retry sequence is invoked.

- Head off track
- External shock
- Low supply voltage
- Spindle speed out of tolerance
- Head open/short

5.5 Data buffer test

The data buffer is tested at power on reset and when a drive self-test is requested by the host. The test consists of a write/read '00'x and 'ff'x pattern on all buffers.

5.6 Error recovery

Errors occurring on the drive are handled by the error recovery procedure.

Errors that are uncorrectable after application of the error recovery procedure are reported to the host system as nonrecoverable errors.

5.7 Automatic reallocation

The sectors that show some errors may be reallocated automatically when specific conditions are met. The drive does not report any auto reallocation to the host system. The conditions for auto reallocation are described below.

5.7.1 Nonrecovered write errors

When a write operation cannot be completed after the Error Recovery Procedure (ERP) is fully carried out, the sectors are reallocated to the spare location. An error is reported to the host system only when the write cache is disabled and the auto reallocation has failed.

5.7.2 Nonrecoverable read error

When a read operation fails after ERP is fully carried out, a hard error is reported to the host system. This location is registered internally as a candidate for the reallocation. When a registered location is specified as a target of a write operation, a sequence of media verification is performed automatically. When the result of this verification meets the required criteria, this sector is reallocated.

5.7.3 Recovered read errors

When a read operation for a sector fails and is recovered at the specific ERP step, the sector is reallocated automatically. A media verification sequence may be run prior to the reallocation according to the predefined conditions.

5.8 ECC

The 40 byte three interleaved ECC processor provides user data verification and correction capability. The first 4 bytes of ECC are check bytes for user data and the other 36 bytes are Read Solomon ECC. Each interleave has 12 bytes for ECC. Hardware logic corrects up to 15 bytes (5 bytes for each interleave) errors on-the-fly.

Following are some examples of error cases. An "O" means that the byte contains no error. An "X" means that at least one bit of the byte is bad.

On The Fly correctable

Byte #	0	1	2	3	4	5	6	7	8	9	1	1	1	1	1	1	1	1	Error byte # for each interleave		
Interleave	A	B	C	A	B	C	A	B	C	A	B	C	A	B	C	A	B	C	A	B	C
Error pattern	X	X	X	X	X	X	X	X	X	X	X	X	X	X	O	O	O		5	5	5
Error pattern	X	X	X	X	X	X	X	X	O	O	O	X	X	X	X	X	X		5	5	5

Uncorrectable

Byte #	0	1	2	3	4	5	6	7	8	9	1	1	1	1	1	1	1	1	Error byte # for each interleave		
Interleave	A	B	C	A	B	C	A	B	C	A	B	C	A	B	C	A	B	C	A	B	C
Error pattern	X	X	X	X	X	X	X	X	X	X	X	X	X	X	X	O	O		6	5	5
Error pattern	X	O	O	X	O	O	X	O	O	X	O	O	X	O	O	X	O	O	6	0	0

Figure 16. Examples of error cases.

This page intentionally left blank.

6.0 Specification

6.1 Environment

6.1.1 Temperature, humidity, and altitude

Item	Operating	Nonoperating
Temperature	5 to 40°C ¹	-40 to 65°C
Relative humidity ²	8 to 90%	5 to 95%
Maximum wet bulb temperature ²	29.4°C	40°C
Maximum temperature gradient	20°C/hour	20°C/hour
Altitude	-300 to 3048 m (10 kft)	-300 to 12,192 m (40 kft)

Figure 17. Environmental condition

¹ The system is responsible for providing sufficient air movement to maintain surface temperatures below 50° C at the center of top cover and below 53° C at the center of the drive circuit board assembly.

² Non-condensing.

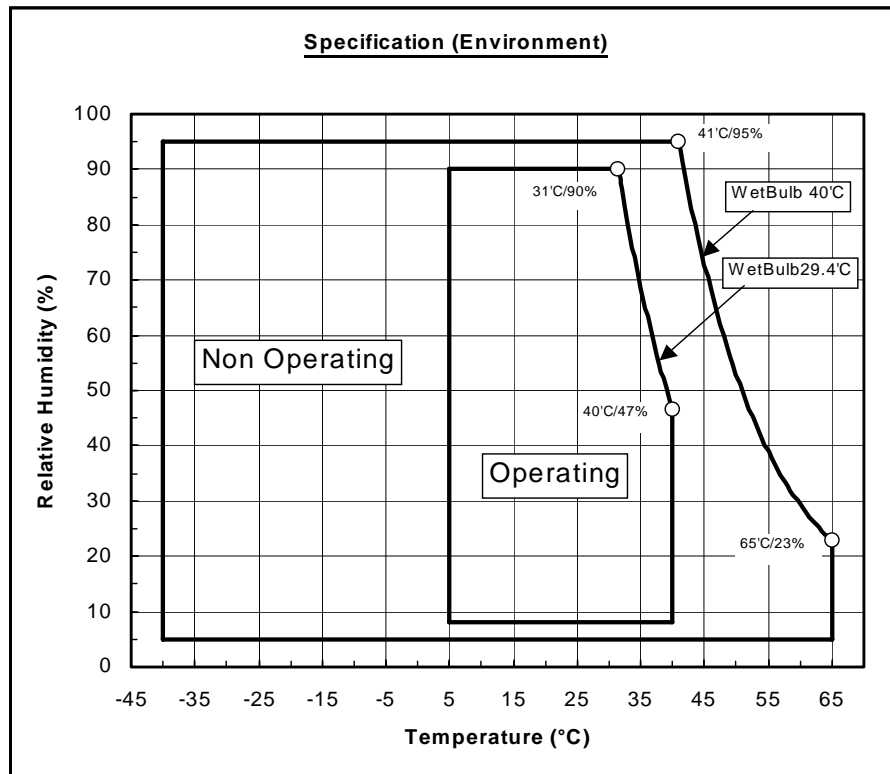

Figure 18. Limits of temperature and humidity

6.1.1.1 Corrosion test

The hard disk drive must be functional and show no signs of corrosion after being exposed to a temperature humidity stress of 50°C/90%RH (relative humidity) for one week followed by a temperature and humidity drop to 25°C/40%RH in 2 hours.

6.1.2 Radiation noise

The disk drive shall work without degradation of the soft error rate under the following magnetic flux density limits at the enclosure surface.

Frequency (KHz)	Limits (Gauss RMS)
0–60	5
61–100	2.5
101–200	1
201–400	0.5

Figure 19. Magnetic flux density limits

6.1.3 Conductive noise

The disk drive shall work without soft error degradation in the frequency range from DC to 20 Mhz injected through any two of the mounting screw holes of the drive when an AC current of up to 45 mA (p-p) is applied through a 50-ohm resistor connected to any two mounting screw holes.

6.1.4 Magnetic fields

The disk drive will withstand radiation and conductive noise within the limits shown below. The test method is defined in the Noise Susceptibility Test Method specification, P/N 95F3944.

6.2 DC power requirements

Connection to the product should be made in a safety extra low voltage (SELV) circuits. The voltage specifications are applied at the power connector of the drive.

Item	Requirements
Nominal supply	+5 Volt dc
Supply voltage	-0.3 Volt to 6.0 Volt
Power supply ripple (0–20 MHz) ¹	100 mV p-p max.
Tolerance ²	±5%
Supply rise time	7–100 ms

Watts (RMS Typical)	Models		
	60 GB	40GB, 30 GB	20GB, 10 GB
Performance Idle average ³	2.0	1.85	1.85
Read average ⁴	2.5	2.1	2.0
Write average	2.7	2.2	2.1
Seek average ⁵	2.6	2.3	2.3
Standby	0.25	0.25	0.25
Sleep	0.1	0.1	0.1
Startup (maximum peak) ⁶	5.0	4.7	4.7
Average from power on to ready	3.8	3.3	3.3

Footnotes:

- ¹ The maximum fixed disk ripple is measured at the 5 volt input of the drive.
- ² The disk drive shall not incur damage for an over voltage condition of +25% (maximum duration of 20 ms) on the 5 volt nominal supply.
- ³ The idle current is specified at an inner track.
- ⁴ The read/write current is specified based on three operations of 63 sector read/write per 100 ms.
- ⁵ The seek average current is specified based on three operations per 100 ms.
- ⁶ The worst case operating current includes motor surge.

Figure 20. DC Power requirements

6.2.1 Power consumption efficiency

Capacity (GB)	60	40	30	20	10
Power Consumption Efficiency (Watts/GB)	0.033	0.046	0.062	0.093	0.185

Figure 21. Power consumption efficiency

Note: Power consumption efficiency is calculated as Power Consumption of Performance Idle Watt/ Capacity (GB).

6.3 Start up Current

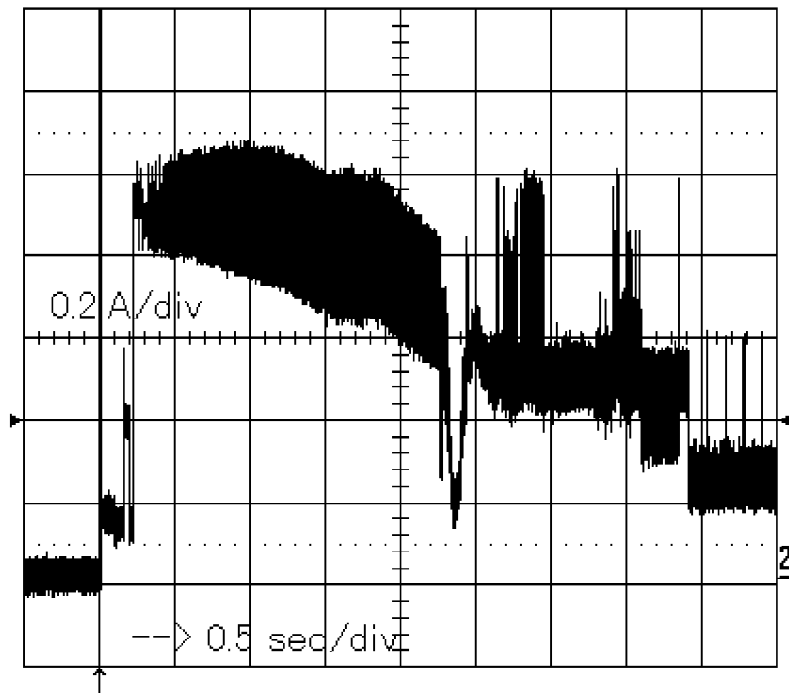

Figure 22. Typical current wave form at start up of 60 GB model

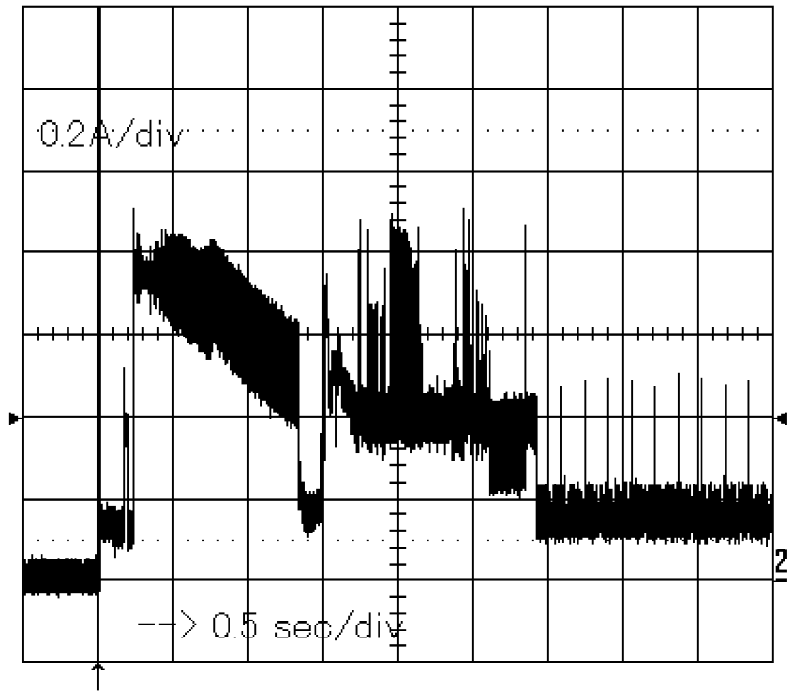

Figure 23. Typical current wave form at start up of 40 GB model

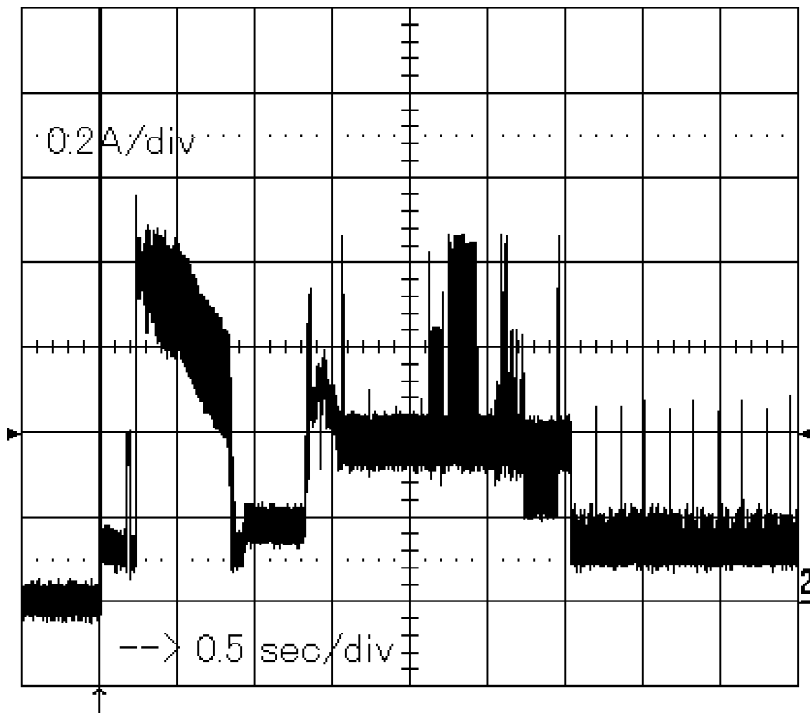

Figure 24. Typical current wave form at start up of 20 GB model)

6.4 Reliability

6.4.1 Data reliability

- Probability of not recovering data is 1 in 10^{13} bits read
- ECC implementation

On-the-fly correction performed as a part of read channel function recovers up to 15 symbols of error in 1 sector (1 symbol is 8 bits).

6.4.2 Failure prediction (S.M.A.R.T.)

The drive supports Self-monitoring, analysis and reporting technology (S.M.A.R.T.) function. The details are described in Section 11.7, "S.M.A.R.T. Function" on page 80 and Section 13.32, "S.M.A.R.T. Function Set (B0h)" on page 161.

6.4.3 Cable noise interference

To avoid any degradation of performance throughput or error when the interface cable is routed on top or comes in contact with the HDA assembly, the drive must be grounded electrically to the system frame by four screws. The common mode noise or voltage level difference between the system frame and power cable ground or AT interface cable ground should be in the allowable level specified in the power requirement section.

6.4.4 Service life and usage condition

The drive is designed to be used under the following conditions:

- The drive should be operated within specifications of shock, vibration, temperature, humidity, altitude, and magnetic field.
- The drive should be protected from ESD.
- The breathing hole in the top cover of the drive should not be covered.
- Force should not be applied to the cover of the drive.
- The specified power requirements of the drive should be satisfied.
- The drive frame should be grounded electrically to the system through four screws.
- The drive should be mounted with the recommended screw depth and torque.
- The interface physical and electrical requirements of the drive should satisfy ATA-5.
- The power-off sequence of the drive should comply with the 6.4.6.2, "Required power-off sequence."

Service life of the drive is approximately 30,000 power on hours, under the following assumptions:

- 732 power on hours per month.
- Seeking/Writing/Reading operation is less than 50% of power on hours.

This does not represent any warranty or warranty period. Applicable warranty and warranty period are covered by the purchase agreement.

6.4.5 Preventive maintenance

None.

6.4.6 Load/unload

The product supports a minimum of 300,000 normal load/unloads.

Load/unload is a functional mechanism of the hard disk drive. It is controlled by the drive micro code. Specifically, unloading of the heads is invoked by the following commands:

- Hard reset
- Standby
- Standby immediate
- Sleep

Load/unload is also invoked as one of the idle modes of the drive.

The specified start/stop life of the product assumes that load/unload is operated normally, not in emergency mode.

6.4.6.1 Emergency unload

When hard disk drive power is interrupted while the heads are still loaded the micro code cannot operate and the normal 5-volt power is unavailable to unload the heads. In this case, normal unload is not possible. The heads are unloaded by routing the back EMF of the spinning motor to the voice coil. The actuator velocity is greater than the normal case and the unload process is inherently less controllable without a normal seek current profile.

Emergency unload is intended to be invoked in rare situations. Because this operation is inherently uncontrolled, it is more mechanically stressful than a normal unload.

The drive supports a minimum of 20,000 emergency unloads.

6.4.6.2 Required Power-Off Sequence

The required BIOS sequence for removing power from the drive is as follows:

- Step 1: Issue one of the following commands.
 - Standby
 - Standby immediate
 - Sleep

Note: Do not use the Flush Cache command for the power off sequence because this command does not invoke Unload.

- Step 2: Wait until the Command Complete status is returned.

In a typical case 350 ms are required for the command to finish completion; however, the BIOS time out value needs to be 30 seconds considering error recovery time. Refer to section 14.0, "Time-out values," on page 191.

- Step 3: Terminate power to HDD.

This power-down sequence should be followed for entry into any system power-down state, system suspend state, or system hibernation state. In a robustly designed system, emergency unload is limited to rare scenarios, such as battery removal during operation.

6.4.6.3 Power switch design considerations

In systems that use the Travelstar 60GH & 40GN consideration should be given to the design of the system power switch.

IBM recommends that the switch operate under control of the BIOS, as opposed to being hardwired. The same recommendation is made for cover-close switches. When a hardwired switch is turned off, emergency unload occurs, as well as the problems cited in section 5.1, "Data loss by power off" on page 19 and section 5.2, "Write Cache" on page 19.

6.4.6.4 Test considerations

Start/stop testing is classically performed to verify head/disk durability. The heads do not land on the disk, so this type of test should be viewed as a test of the load/unload function.

Start/Stop testing should be done by commands through the interface, not by power cycling the drive. Simple power cycling of the drive invokes the emergency unload mechanism and subjects the HDD to nontypical mechanical stress.

Power cycling testing may be required to test the boot-up function of the system. In this case IBM recommends that the power-off portion of the cycle contain the sequence specified in section 6.4.6.2, "Required Power-Off Sequence" on page 29. If this is not done, the emergency unload function is invoked and nontypical stress results.

6.5 Mechanical specifications

6.5.1 Physical dimensions and weight

The following figure lists the dimensions for the drive.

Models	Height (mm)	Width (mm)	Length (mm)	Weight (gram)
60 GB	12.5±0.2	69.85±0.25	100.2±0.25	155 Max
40 GB, 30 GB	9.5±0.2	69.85±0.25	100.2±0.25	99 Max
20 GB, 10 GB	9.5±0.2	69.85±0.25	100.2±0.25	95 Max

Figure 25. Physical dimensions and weight

6.5.2 Mounting hole locations

The mounting hole locations and size of the drive are shown below.

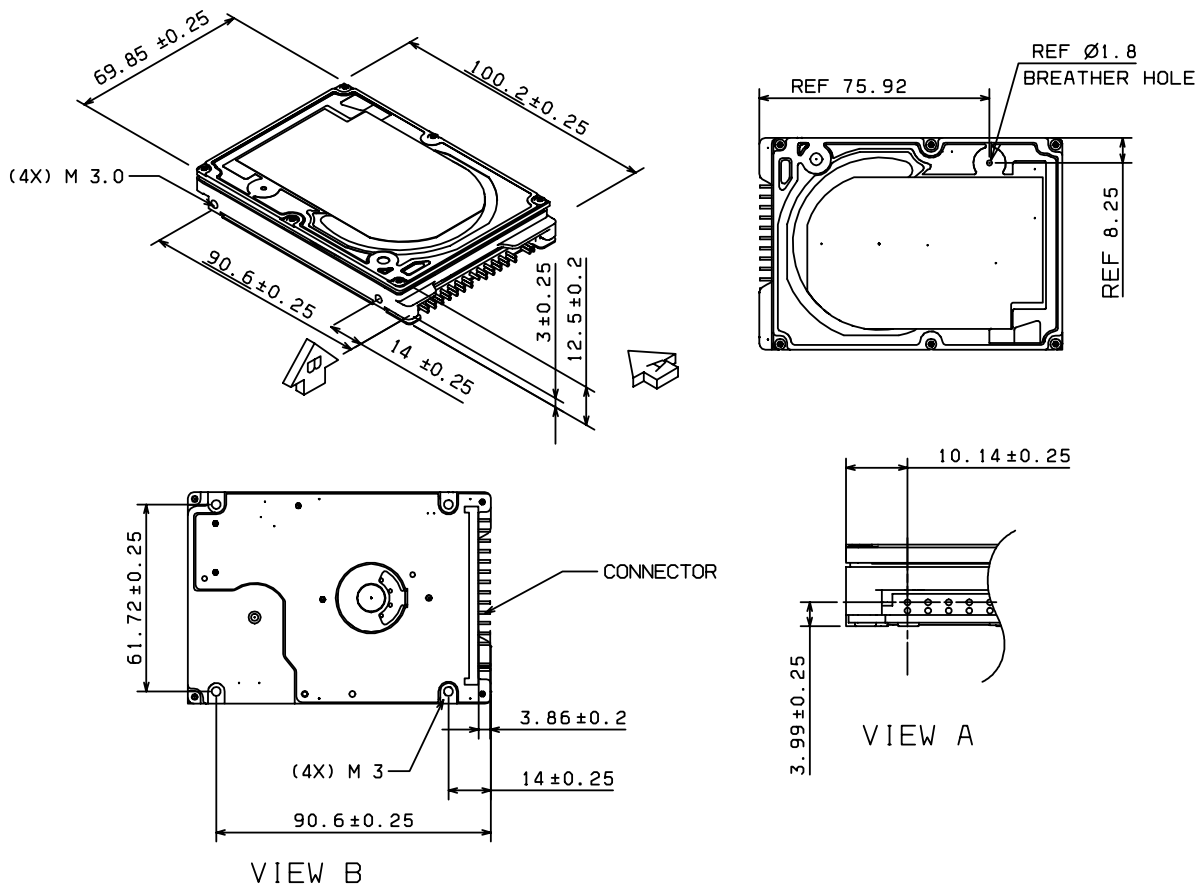

Figure 26. Mounting hole locations of the 60 GB model.

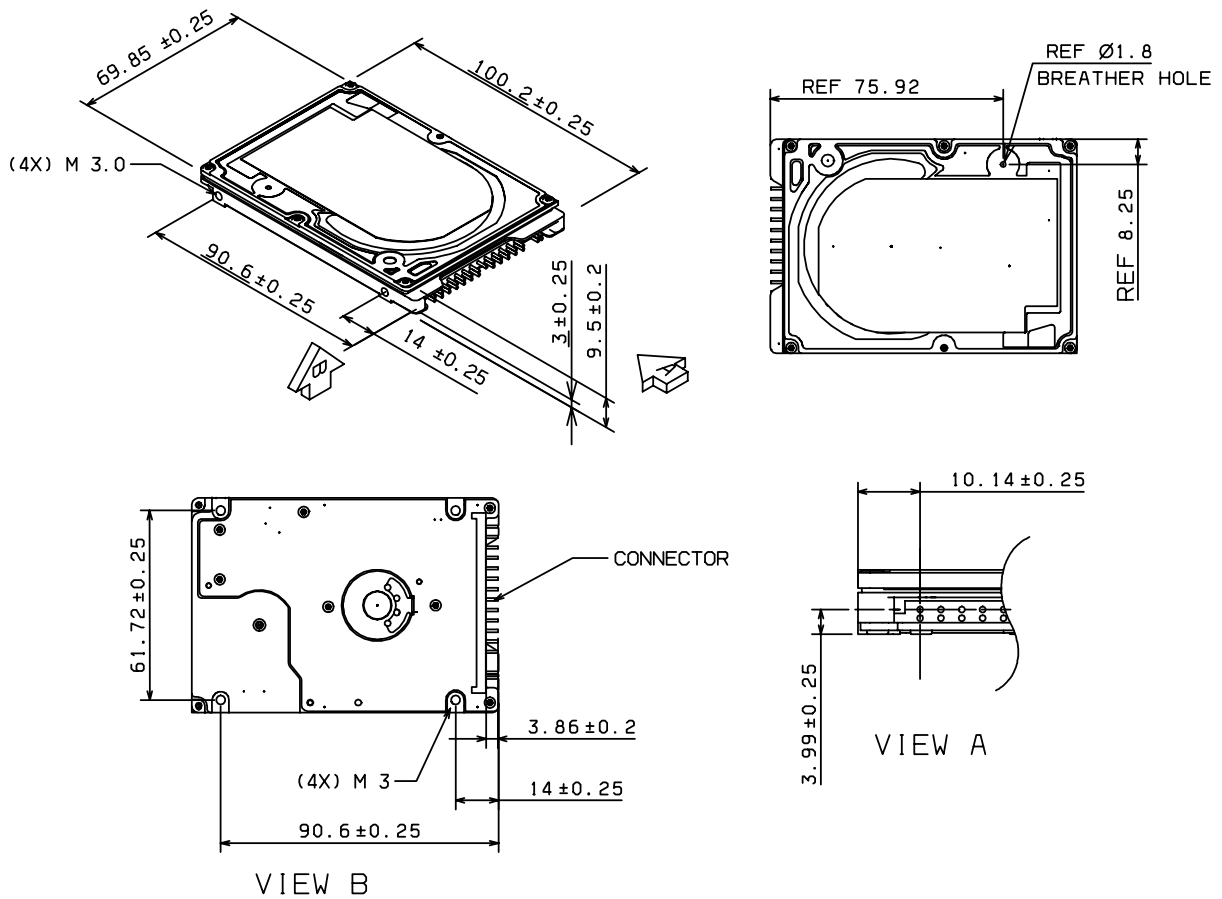

Figure 27. Mounting hole locations of all models except 60 GB model.

6.5.3 Connector and jumper description

A jumper is used to designate the drive address as either master or slave. The jumper setting method is described in section 7.10, "Drive address setting" on page 58.

Connector specifications are included in section 7.2, "Interface connector" on page 41.

6.5.4 Mounting orientation

The drive will operate in all axes (six directions) and will stay within the specified error rates when tilted ± 5 degrees from these positions.

Performance and error rate will stay within specification limits if the drive is operated in the other permissible orientations from which it was formatted. Thus a drive formatted in a horizontal orientation will be able to run vertically and vice versa.

The recommended mounting screw torque is 3.0 ± 0.5 kgf-cm.

The recommended mounting screw depth is 3.0 ± 0.3 mm for bottom and 3.5 ± 0.5 mm for horizontal mounting.

The user is responsible for using the appropriate screws or equivalent mounting hardware to mount the drive securely enough to prevent excessive motion or vibration of the drive at seek operation or spindle rotation.

6.5.5 Load/unload mechanism

The head load/unload mechanism is provided to protect the disk data during shipping, movement, or storage. Upon power down, a head unload mechanism secures the heads at the unload position. See section 6.6.4, "Nonoperating shock" on page 36 for additional details.

6.6 Vibration and shock

All vibration and shock measurements in this section are for drives without mounting attachments for systems. The input level shall be applied to the normal drive mounting points.

Vibration tests and shock tests are to be conducted by mounting the drive to a table using the bottom four mounting holes.

6.6.1 Operating vibration

The drive will operate without a hard error while being subjected to the following vibration levels.

6.6.1.1 Random vibration

The test consists of 30 minutes of random vibration using the power spectral density (PSD) levels below. The vibration test level is 6.57 m/sec² RMS (Root Mean Square) (0.67 G RMS).

Random vibration PSD profile Breakpoint	
Hz	G ² /Hz
5	2.0 x E-5
17	1.1 x E-3
45	1.1 x E-3
48	8.0 x E-3
62	8.0 x E-3
65	1.0 x E-3
150	1.0 x E-3
200	5.0 x E-4
500	5.0 x E-4

Figure 28. Random vibration PSD profile breakpoints (operating)

6.6.1.2 Swept sine vibration

Models	Swept sine vibration (zero to peak 5 to 500 to 5 Hz sine wave)	Sweep rate (oct/min)
60 GB	1 G (5-300 Hz) 1 G (300 Hz) – 0.33 G (350 Hz) 0.33 G (350-500 Hz)	2.0
All others	1 G (5-500 Hz)	2.0

Figure 29. Swept sine vibration

6.6.2 Nonoperating vibration

The disk drive withstands the following vibration levels without any loss or permanent damage.

6.6.2.1 Random vibration

The test consists of a random vibration applied in each of three mutually perpendicular axes for a duration of 15 minutes per axis. The PSD levels for the test simulating the shipping and relocation environment is shown below.

Hz	G ² /Hz
2.5	0.001
5	0.03
40	0.018
500	0.018

Figure 30. Random Vibration PSD Profile Breakpoints (nonoperating)

Note: Overall RMS (root mean square) level of vibration is 3.01 G rms.

6.6.2.2 Swept sine vibration

- 5 G (zero-to-peak), 5 to 500 to 10 Hz sine wave
- 0.5 oct/min sweep rate
- 25.4 mm (peak-to-peak) displacement, 5 to 10 to 5 Hz

6.6.3 Operating shock

The hard disk drive meets the criteria in the table below while operating under these conditions:

- The shock test consists of 10 shock inputs in each axis and direction for a total of 60.
- There must be a minimum delay of 3 seconds between shock pulses.
- The disk drive will operate without a hard error while subjected to the following half-sine shock pulse.

Models	Duration of 2 ms	Duration of 11 ms
60 GB	150 G	15 G
All others	200 G	15 G

Figure 31. Operating shock

The input level shall be applied to the normal disk drive subsystem mounting points used to secure the drive in a normal system.

6.6.4 Nonoperating shock

The drive withstands the following half-sine shock pulse without any data loss or permanent damage.

Models	Duration of 1 ms	Duration of 11 ms
60 GB	700 G	120 G
All others	800 G	120 G

Figure 32. Nonoperating shock

The shocks are applied for each direction of the drive for three mutually perpendicular axes, one axis at a time. Input levels are measured on a base plate where the drive is attached with four screws.

6.7 Acoustics

6.7.1 Sound power level

The criteria of A-weighted sound power level are described below.

Measurements are to be taken in accordance with ISO 7779. The mean of the sample of 40 drives is to be less than the typical value. Each drive is to be less than the maximum value. The drives are to meet this requirement in both board down orientations.

A-weighted Sound Power	Typical (Bels)		Maximum (Bels)	
	Idle	Operating	Idle	Operating
48 GB model	2.5	3.5	2.7	3.8
30 GB and 20 GB models	2.4	3.1	2.6	3.3
All other models	2.1	2.7	2.4	2.9

Figure 33. Weighted sound power

The background power levels of the acoustic test chamber for each octave band are to be recorded.

Sound power tests are to be conducted with the drive supported by spacers so that the lower surface of the drive be located 25±3 mm above from the chamber floor. No sound absorbing material shall be used.

The acoustical characteristics of the disk drive are measured under the following conditions:

Mode definitions

- Idle mode: Power on, disks spinning, track following, unit ready to receive and respond to control line commands.
- Operating mode: Continuous random cylinder selection and seek operation of the actuator with a dwell time at each cylinder. The seek rate for the drive can be calculated as shown below.

$$N_s = 0.4 / (T_t + T_1)$$

where:

N_s = average seek rate in seeks/s

T_t = published seek time from one random track to another without including rotational latency

T_1 = equivalent time in seconds for the drive to rotate by half a revolution

6.7.2 Discrete tone penalty

Discrete tone penalties are added to the A-weighted sound power (L_w) with the following formula only when determining compliance.

$$L_{wt(spec)} = L_w + 0.1P_t + 0.3 < 4.0 \text{ (Bels)}$$

where

L_w = A-weighted sound power level

P_t = Value of discrete tone penalty = $dL_t - 6.0$ (dBA)

dL_t = Tone-to-noise ratio taken in accordance with ISO 7779 at each octave band.

6.8 Identification labels

The following labels are affixed to every drive:

- A label which is placed on the top of the head disk assembly containing the statement "Made by IBM" or equivalent, part number, EC number, and FRU number.
- A bar code label which is placed on the disk drive based on user request. The location on the disk drive is to be designated in the drawing provided by the user.
- Labels containing the vendor's name, disk drive model number, serial number, place of manufacture, and UL/CSA logos.
- The presence of labels containing jumper information depends on the customer.

6.9 Electromagnetic compatibility

When installed in a suitable enclosure and exercised with a random accessing routine at maximum data rate, the drive meets the following worldwide electromagnetic compatibility (EMC) requirements:

- United States Federal Communications Commission (FCC) Rules and Regulations (Class B), Part 15. RFI Suppression German National Requirements
- RFI Japan VCCI, Requirements of IBM products
- EU EMC Directive, Technical Requirements and Conformity Assessment Procedures

6.9.1 CE Mark

The product is certified for compliance with EC directive 89/336/EEC. The EC marking for the certification appears on the drive.

6.9.2 C-Tick Mark

The product complies with the Australian EMC standard "Limits and methods of measurement of radio disturbance characteristics of information technology equipment, AS/NZS 3548:1995 Class B."

6.10 Safety

6.10.1 UL and CSA approval

The product is qualified per UL (Underwriters Laboratory) 1950 Third Edition and CAN/CSA C22.2 No.950-M95 Third Edition, for the use in Information Technology Equipment, including Electric Business Equipment. The UL Recognition or the CSA certification is maintained for the product life. The UL and C-UL recognition mark or the CSA monogram for CSA certification appears on the drive.

6.10.2 IEC compliance

All models of the Travelstar 60GH & 40GN comply with IEC 950:1991 +A1-4.

6.10.3 German Safety Mark

All models of the Travelstar 60GH & 40GN are approved by TUV on Test Requirement: EN 60950:1992+A1-4, but the GS mark has not been obtained.

6.10.4 Flammability

The printed circuit boards used in this product are made of material with a UL recognized flammability rating of V-1 or better. The flammability rating is marked or etched on the board. All other parts not considered electrical components are made of material with a UL recognized flammability rating of V-1 or better except minor mechanical parts.

6.10.5 Secondary circuit protection

This product utilizes printed circuit wiring that must be protected against the possibility of sustained combustion due to circuit or component failures as defined in C-B 2-4700-034 (Protection Against Combustion). Adequate secondary over current protection is the responsibility of the using system.

The user must protect the drive from its electrical short circuit problem. A 10 amp limit is required for safety purpose.

6.11 Packaging

Drives are packed in ESD protective bags and shipped in appropriate containers.

7.0 Electrical interface specifications

7.1 Cabling

The maximum cable length from the host system to the hard disk drive plus circuit pattern length in the host system shall not exceed 45.7 cm.

7.2 Interface connector

The signal connector for AT attachment is designed to mate with Dupont part number 69764-044 or equivalent.

The figure below and the figures in Section 6.5.2 beginning on page 31 show the connector location and physical pin location.

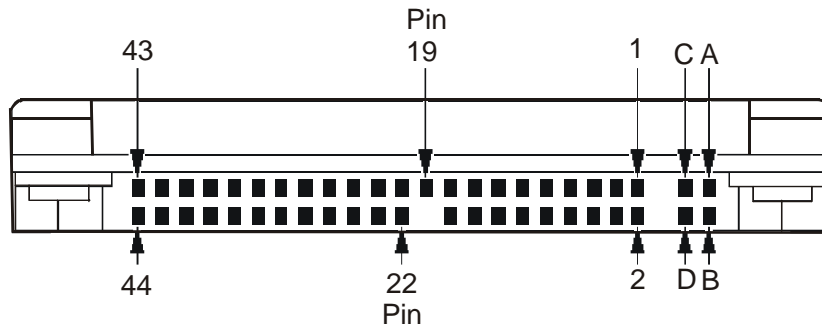

Pin position 20 is left blank for correct connector insertion.

Pin positions A, B, C, and D are used for the drive address setting. (Refer to Figure 48 on page 58 for correct address setting.)

Figure 34. Interface connector pin assignments

7.3 Signal definitions

The pin assignments of interface signals are listed as follows:

PIN	SIGNAL	I/O	Type	PIN	SIGNAL	I/O	Type
01	RESET-	I	TTL	02	GND		
03	DD07	I/O	3-state	04	DD08	I/O	3-state
05	DD06	I/O	3-state	06	DD09	I/O	3-state
07	DD05	I/O	3-state	08	DD10	I/O	3-state
09	DD04	I/O	3-state	10	DD11	I/O	3-state
11	DD03	I/O	3-state	12	DD12	I/O	3-state
13	DD02	I/O	3-state	14	DD13	I/O	3-state
15	DD01	I/O	3-state	16	DD14	I/O	3-state
17	DD00	I/O	3-state	18	DD15	I/O	3-state
19	GND			(20)	Key		
21	DMARQ	O	3-state	22	GND		
23	DIOW(*)-	I	TTL	24	GND		
25	DIOR(*)-	I	TTL	26	GND		
27	IORDY(*)	O	3-state	28	CSEL	I	TTL
29	DMACK-	I	TTL	30	GND		
31	INTRQ	O	3-state	32	IOCS16(*)-	O	OD
33	DA01	I	TTL	34	PDIAG-	I/O	OD
35	DA00	I	TTL	36	DA02	I	TTL
37	CS0-	I	TTL	38	CS1-	I	TTL
39	DASP-	I/O	OD	40	GND		
41	+ 5V logic	power		42	+ 5V motor	power	
43	GND			44	(reserved)		

O	designates an output from the drive
I	designates an input to the drive
I/O	designates an input/output common
OD	designates an Open-Drain output
power	designates a power supply to the drive
reserved	designates reserved pins which must be left unconnected

Figure 35. Signal definition

The signal lines marked with (*) are redefined during the Ultra DMA protocol to provide special functions. These lines change from the conventional to special definitions at the moment the host decides to allow a DMA burst, if the Ultra DMA transfer mode was previously chosen via SetFeatures. The drive becomes aware of this change upon assertion of the DMACK- line. These lines revert back to their original definitions upon the deassertion of DMACK- at the termination of the DMA burst.

	Special Definition (for Ultra DMA)	Conventional Definition
Write Operation	DDMARDY-	IORDY
	HSTROBE	DIOR-
	STOP	DIOW-
Read Operation	HDMARDY-	DIOR-
	DSTROBE	IORDY
	STOP	DIOW-

Figure 36. Special signal definitions for Ultra DMA

7.4 Signal descriptions

DD00–DD15

A 16-bit bi-directional data bus between the host and the drive. The lower 8 lines, DD00-07, are used for Register and ECC access. All 16 lines, DD00–15, are used for data transfer. These are 3-state lines with 24 mA current sink capability.

DA00–DA02

These are addresses used to select the individual register in the drive.

CS0-

The chip select signal generated from the Host address bus. When active, one of the Command Block Registers [Data, Error (Features when written), Sector Count, Sector Number, Cylinder Low, Cylinder High, Drive/Head and Status (Command when written) register] can be selected.

CS1-

The chip select signal generated from the Host address bus. When active, one of the Control Block Registers [Alternate Status (Device Control when written) and Drive Address register] can be selected.

RESET-

This line is used to reset the drive. It shall be kept at a Low logic state during power up and kept High thereafter.

DIOW-

The rising edge of this signal holds data from the data bus to a register or data register of the drive.

DIOR-

When this signal is low, it enables data from a register or data register of the drive onto the data bus. The data on the bus shall be latched on the rising edge of DIOR-

INTRQ

The interrupt is enabled only when the drive is selected and the host activates the IEN- bit in the Device Control Register. Otherwise, this signal is in high impedance state regardless of the state of the IRQ bit. The interrupt is set when the IRQ bit is set by the drive CPU. The IRQ is reset to zero by a host read of the status register or a write to the Command Register. This signal is a 3-state line with 24 mA of sink capability.

IOCS16-

A signal indicating to the host that a 16-bit wide data register has been addressed and that the drive is prepared to send or receive a 16-bit wide data word. This signal is an Open-Drain output with 24 mA sink capability and an external resistor is needed to pull this line to 5 volts.

DASP-

This is a time-multiplexed signal which indicates that a drive is active or that device 1 is present. This signal is driven by an Open-Drain driver and internally pulled up to 5 volts through a 10 kΩ resistor. During a Power-On initialization or after RESET- is negated, DASP- shall be asserted by Device 1 within 400 ms to indicate that device 1 is present. Device 0 shall allow up to 450 ms for device 1 to assert DASP-. If device 1 is not present, device 0 may assert DASP- to drive an LED indicator. The DASP- signal shall be negated following acceptance of the first valid command by device 1. Anytime after negation of DASP-, either drive may assert DASP- to indicate that a drive is active.

PDIAG-

This signal shall be asserted by device 1 to indicate to device 0 that it has completed the diagnostics. This line is pulled up to 5 volts in the drive through a 10 k Ω resistor.

Following a Power On Reset, software reset, or RESET-, drive 1 shall negate PDIAG- within 1 ms (to indicate to device 0 that it is busy). Drive 1 shall then assert PDIAG- within 30 seconds to indicate that it is no longer busy and is able to provide status.

Following the receipt of a valid Execute Drive Diagnostics command, device 1 shall negate PDIAG- within 1 ms to indicate to device 0 that it is busy and has not yet passed its drive diagnostics. If device 1 is present then device 0 shall wait up to 6 seconds from the receipt of a valid Execute Drive Diagnostics command for drive 1 to assert PDIAG-. Device 1 should clear BSY before asserting PDIAG-, as PDIAG- is used to indicate that device 1 has passed its diagnostics and is ready to post status. If DASP- was not asserted by device 1 during reset initialization, device 0 shall post its own status immediately after it completes diagnostics and clears the device 1 Status register to 00h. Device 0 may be unable to accept commands until it has finished its reset procedure and is ready (DRDY=1).

CSEL (Cable Select)

This signal is monitored to determine the drive address (master or slave) when the jumper on the interface connector is at Position-3.

When CSEL is at ground or is at a low level, the drive works as a Master. If CSEL is open or is at a logical high level, the drive works as a Slave.

The signal level of CSEL to one drive should be different from the signal level to another drive on the same AT interface cable to avoid master-master or slave-slave configurations.

KEY

Pin position 20 has no connection pin. It is recommended to close the respective position of the cable connector in order to avoid incorrect insertion.

IORDY

This signal is an indication to the host that the drive is ready to complete the current I/O cycle. This line is driven low at the falling edge of DIOR- or DIOW- when the drive needs some additional WAIT cycle(s) to extend the PIO cycle. This line can be connected to the host IORDY signal in order to insert a WAIT state(s) into the host PIO cycle. This signal is an Open-Drain output with 24 mA sink capability.

5V Power

There are two input pins for the +5 V power supply. One is the "+5 V Logic" input pin and the second is the "+5 V Motor" input pin. These two input pins are tied together within the drive.

DMACK-

This signal shall be used by the host in response to DMARQ to either acknowledge that data has been accepted, or that data is available.

This signal is internally pulled up to 5 Volt through a 15 k Ω resistor with a resistor tolerance value of -50% to +100%.

DMARQ

This signal is used for DMA data transfers between the host and drive. It shall be asserted by the drive when it is ready to transfer data to or from the host. The direction of data transfer is controlled by HIOR- and HIOW- signals. This signal is used in a handshake mode with DMACK-. This signal is a 3-state line with 24 mA sink capability and internally pulled down to GND through a 10 k Ω resistor.

HDMARDY- (Ultra DMA)

This signal is used only for Ultra DMA data transfers between host and drive.

The signal HDMARDY- is a flow control signal for Ultra DMA data in bursts. This signal is held asserted by the host to indicate to the device that the host is ready to receive Ultra DMA data in transfers. The host may negate HDMARDY- to pause an Ultra DMA data in transfer.

HSTROBE (Ultra DMA)

This signal is used only for Ultra DMA data transfers between host and drive.

The signal HSTROBE is the data out strobe signal from the host for an Ultra DMA data out transfer. Both the rising and falling edge of HSTROBE latch the data from DD (15:0) into the device. The host may stop toggling HSTROBE to pause an Ultra DMA data out transfer.

STOP (Ultra DMA)

This signal is used only for Ultra DMA data transfers between host and drive.

The STOP signal shall be asserted by the host prior to initiation of an Ultra DMA burst. A STOP shall be negated by the host before data is transferred in an Ultra DMA burst. Assertion of STOP by the host during or after data transfer in an Ultra DMA mode signals the termination of the burst.

DDMARDY- (Ultra DMA)

This signal is used only for Ultra DMA data transfers between host and drive.

The signal DDMARDY- is a flow control signal for Ultra DMA data out bursts. This signal is held asserted by the device to indicate to the host that the device is ready to receive Ultra DMA data out transfers. The device may negate DDMARDY- to pause an Ultra DMA data out transfer.

DSTROBE (Ultra DMA)

This signal is used only for Ultra DMA data transfers between host and drive.

The signal DSTROBE is the data in strobe signal from the device for an Ultra DMA data in transfer. Both the rising and the falling edge of DSTROBE latch the data from DD (15:0) into the host. The device may stop toggling DSTROBE to pause an Ultra DMA data in transfer.

7.5 Interface logic signal levels

The interface logic signals have the following electrical specifications:

Inputs	Input High Voltage	2.0 V min./5.5 V max.
	Input Low Voltage	-0.5 V min./0.8 V max.
Outputs:	Output High Voltage	2.4 V min.
	Output Low Voltage	0.5 V max.
Current	Driver Sink Current	24 mA min.
	Driver Source Current	-400 μ A min.

7.6 Reset timings

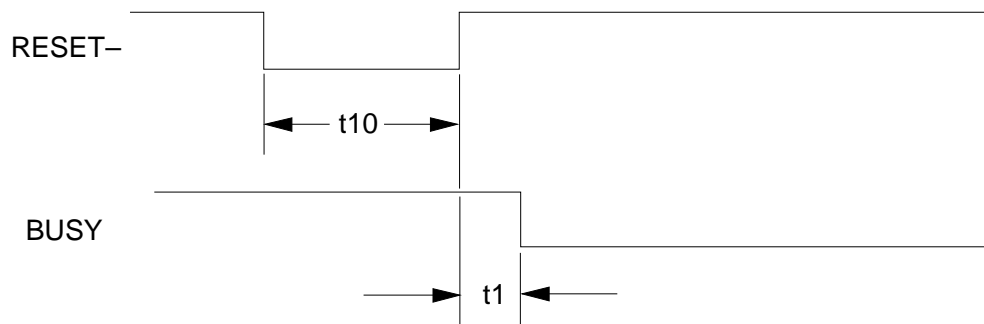

	PARAMETER DESCRIPTION	Min. (μ s)	Max. (μ s)
t1	RESET- high to Not BUSY	-	9.5
t10	RESET- low width	25	-

Figure 37. System reset timings

7.7 PIO timings

The PIO cycle timings meet Mode 4 of the ATA-3 description.

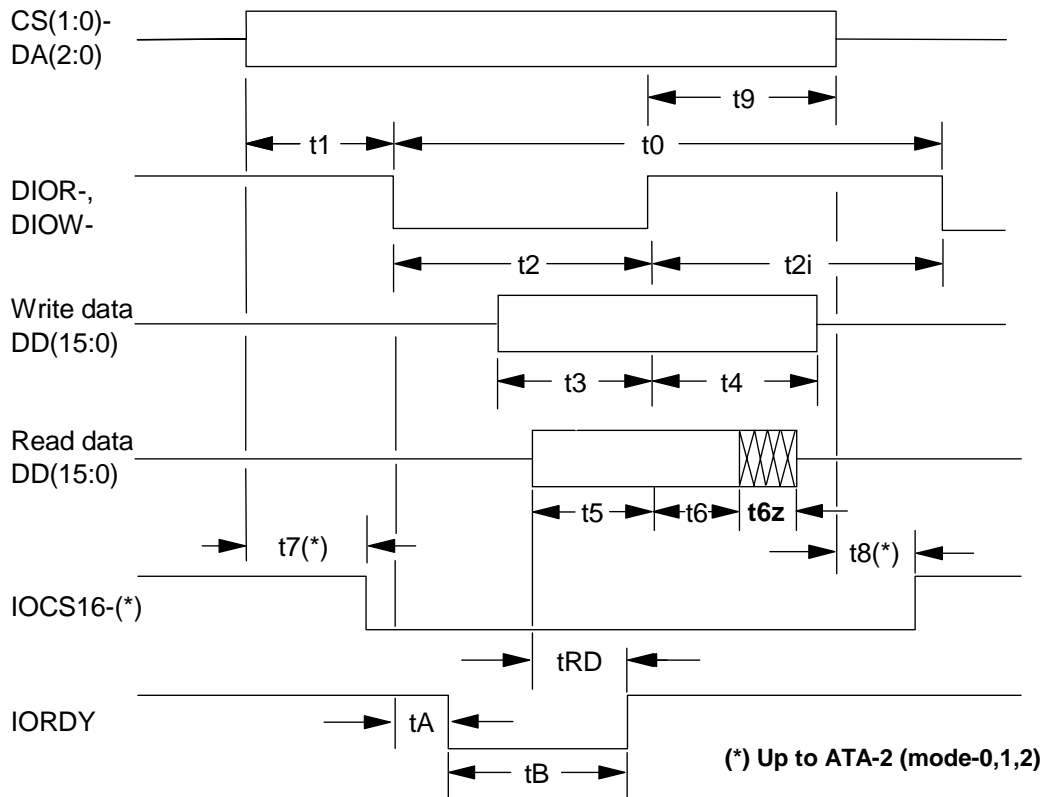

	PARAMETER DESCRIPTION	MIN (ns)	MAX. (ns)
t0	Cycle time	120	–
t1	Address valid to DIOR-/DIOW- setup	25	–
t2	DIOR-/DIOW- pulse width	70	–
t2i	DIOR-/DIOW- recovery time	25	–
t3	DIOW- data setup	20	–
t4	DIOW- data hold	10	–
t5	DIOR- data setup	20	–
t6	DIOR- data hold	5	–
t6z	DIOR- data tristate	–	30
t7(*)	Address valid to IOCS16- assertion	–	40
t8(*)	Address valid to IOCS16- released	–	30
t9	DIOR-/DIOW- to address valid hold	10	–
tRD	Read data valid to IORDY active	0	–
tA	IORDY setup width	–	35
tB	IORDY pulse width	–	1,250

Figure 38. PIO cycle timings

7.8 Multiword DMA timings

The Multiword DMA timings meet Mode 2 of the ATA-3 description.

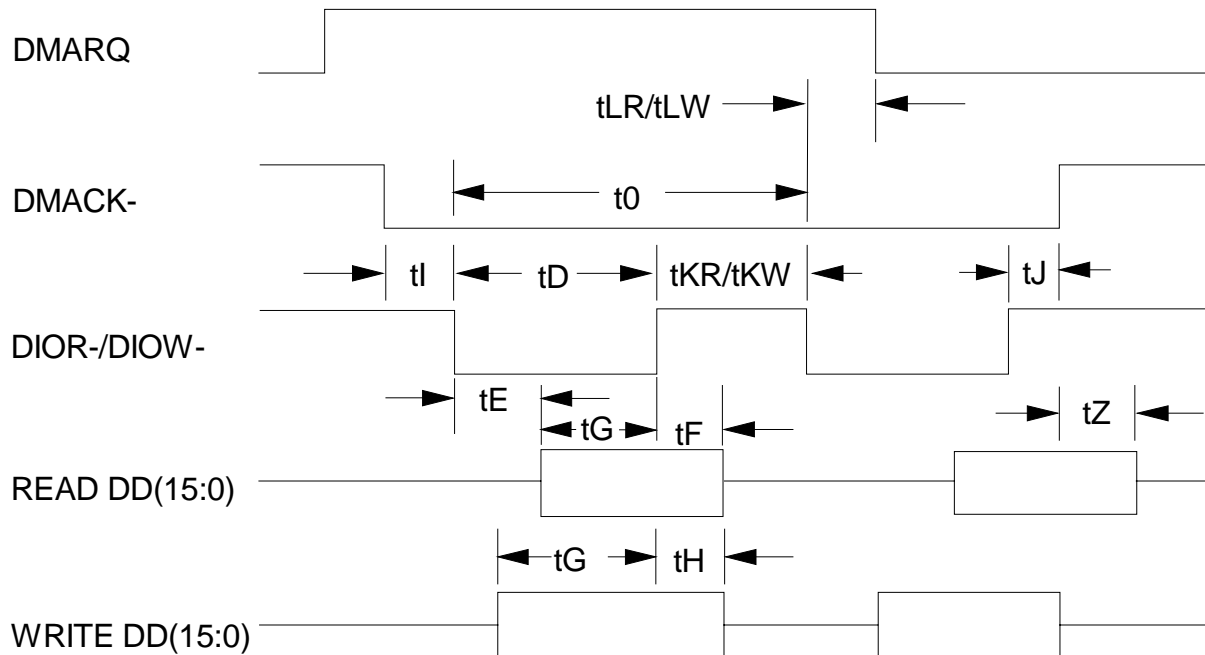

	PARAMETER DESCRIPTION	MIN (ns)	MAX (ns)
t_0	Cycle time	120	–
t_D	DIOR-/DIOW- asserted pulse width	70	–
t_E	DIOR- data access	–	50
t_F	DIOR- data hold	5	–
t_G	DIOR-/DIOW- data setup	20	–
t_H	DIOW- data hold	10	–
t_I	DMACK- to DIOR-/DIOW- setup	0	–
t_J	DIOR-/DIOW- to DMACK- hold	5	–
t_{KR}/t_{KW}	DIOR- negated pulse width / DIOW- negated pulse width	25	–
t_{LR}/t_{LW}	DIOR- to DMARQ delay / DIOW- to DMARQ delay	–	35
t_Z	DMACK- to read data released	–	25

Figure 39. Multiword DMA cycle timings

7.9 Ultra DMA timings

The Ultra DMA timings meet Mode 0, 1, 2, 3, 4, and 5 of the Ultra DMA Protocol.

7.9.1 Initiating Read DMA

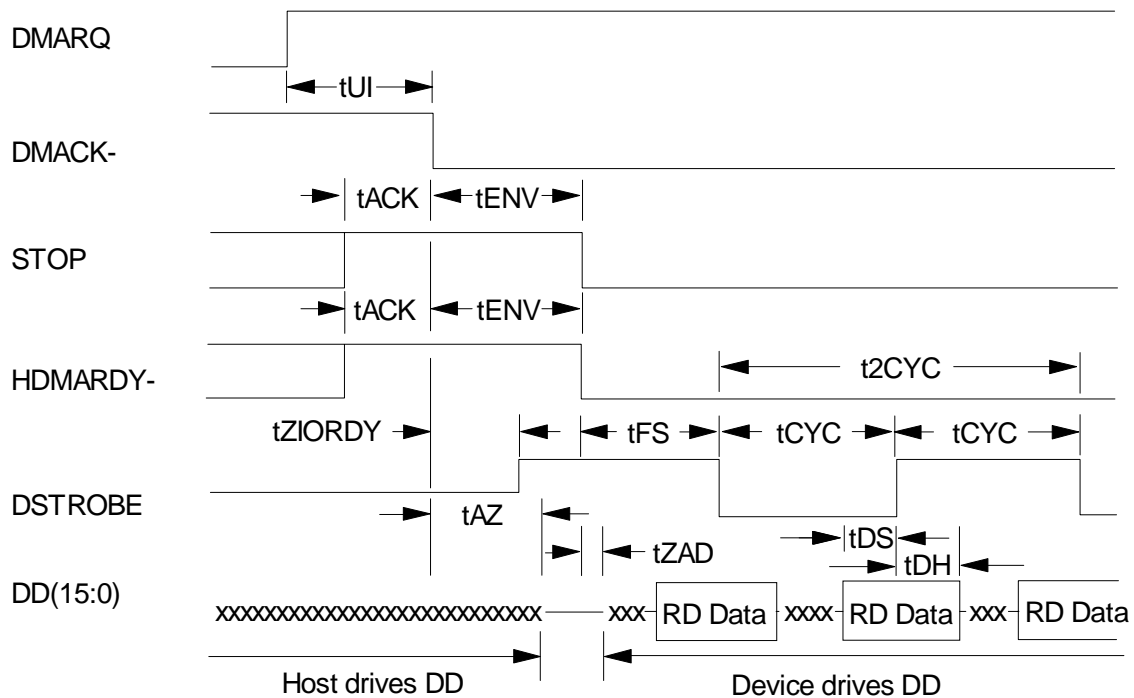

	PARAMETER DESCRIPTION	MODE 0		MODE 1		MODE 2		MODE 3		MODE 4		MODE 5	
		MIN (ns)	MAX (ns)	MIN (ns)	MAX (ns)	MIN (ns)	MAX (ns)	MIN (ns)	MAX (ns)	MIN (ns)	MAX (ns)	MIN (ns)	MAX (ns)
t_{UI}	Unlimited interlock time	0	-	0	-	0	-	0	-	0	-	0	-
t_{ACK}	Setup time for DMACK-	20	-	20	-	20	-	20	-	20	-	20	-
t_{ENV}	Envelope time	20	70	20	70	20	70	20	55	20	55	20	50
t_{ZIORDY}	Minimum time before driving IORDY	0	-	0	-	0	-	0	-	0	-	0	-
t_{FS}	First DSTROBE time	0	230	0	200	0	170	0	130	0	120	-	90
t_{CYC}	Cycle time	112	-	73	-	54	-	39	-	25	-	16.8	-
t_{2CYC}	Two cycle time	230	-	154	-	115	-	86	-	57	-	38	-
t_{AZ}	Maximum time allowed for output drivers to release	-	10	-	10	-	10	-	10	-	10	-	10
t_{ZAD}	Drivers to assert	0	-	0	-	0	-	0	-	0	-	0	-
t_{DS}	Data setup time at host	15	-	10	-	7	-	7	-	5	-	4.8	-
t_{DH}	Data hold time at host	5	-	5	-	5	-	5	-	5	-	4.8	-

Figure 40. Ultra DMA cycle timings (Initiating Read)

7.9.2 Host Pausing Read DMA

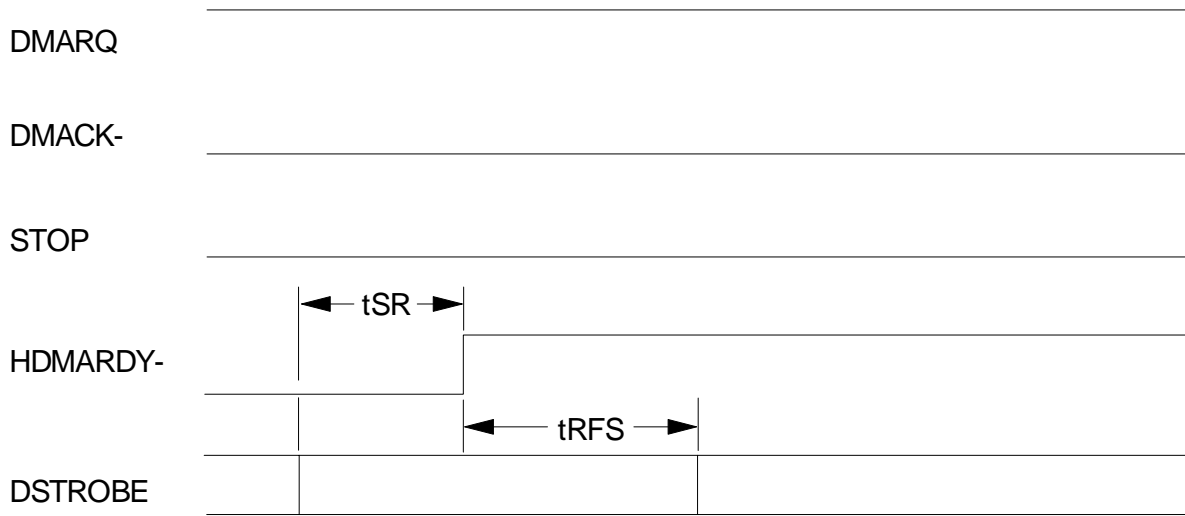

	PARAMETER DESCRIPTION	MODE 0		MODE 1		MODE 2		MODE 3		MODE 4		MODE 5	
		MIN (ns)	MAX (ns)	MIN (ns)	MAX (ns)	MIN (ns)	MAX (ns)	MIN (ns)	MAX (ns)	MIN (ns)	MAX (ns)	MIN (ns)	MAX (ns)
tSR	DSTROBE to HDMARDY-time	-	50	-	30	-	20	-	-	-	-	-	-
tRFS	HDMARDY- to final DSTROBE time	-	75	-	70	-	60	-	60	-	60	-	50

Note: When a host does not satisfy the tSR timing, the host should be ready to receive two more data words after HDMARDY- is negated.

Figure 41. Ultra DMA cycle timings (Host Pausing Read)

7.9.3 Host Terminating Read DMA

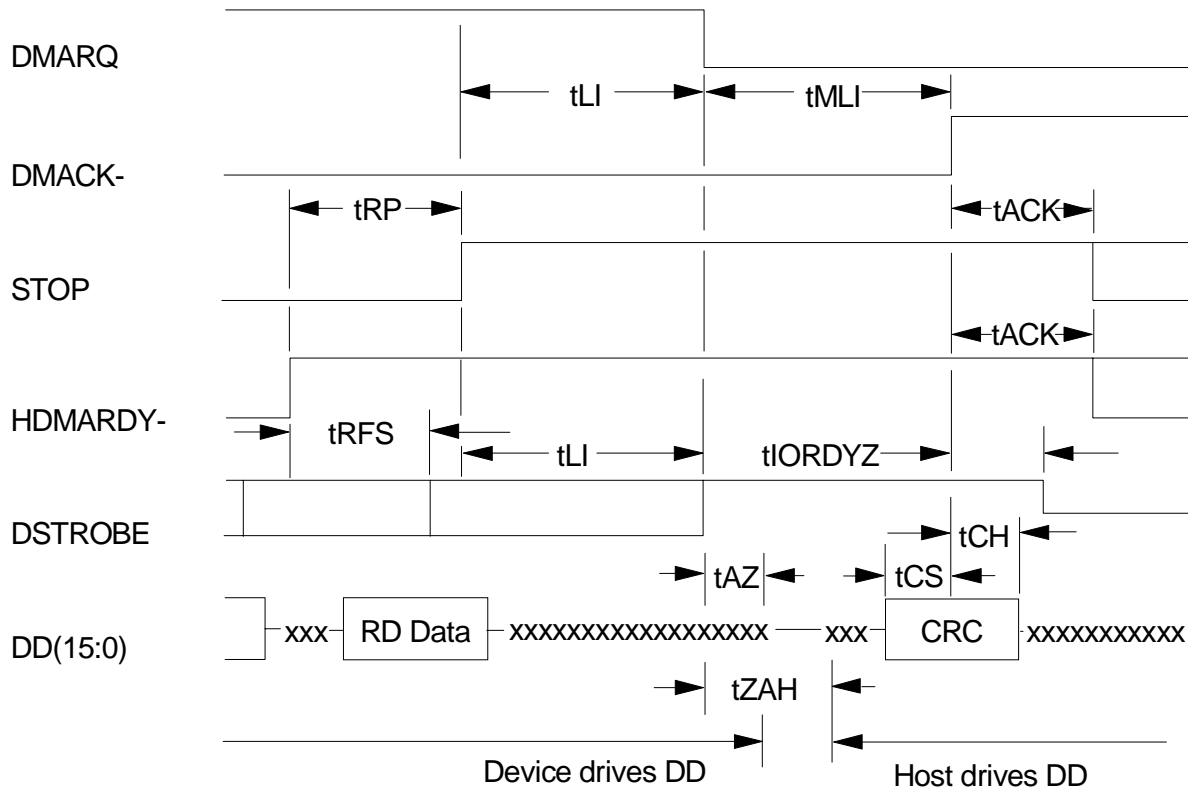

	PARAMETER DESCRIPTION	MODE 0		MODE 1		MODE 2		MODE 3		MODE 4		MODE 5	
		MIN (ns)	MAX (ns)	MIN (ns)	MAX (ns)	MIN (ns)	MAX (ns)	MIN (ns)	MAX (ns)	MIN (ns)	MAX (ns)	MIN (ns)	MAX (ns)
tRFS	HDMARDY- to final DSTROBE time	-	75	-	70	-	60	-	60	-	60	-	50
tRP	Ready to pause time	160	-	125	-	100	-	100	-	100	-	85	-
tLI	Limited interlock time	0	150	0	150	0	150	0	100	0	100	0	75
tAZ	Maximum time allowed for output drivers to release	-	10	-	10	-	10	-	10	-	10	-	10
tZAH	Minimum delay time required for output	20	-	20	-	20	-	20	-	20	-	20	-
tMLI	Interlock time with minimum	20	-	20	-	20	-	20	-	20	-	20	-
tCS	CRC word setup time at device	15	-	10	-	7	-	7	-	5	-	4	-
tCH	CRC word hold time at device	5	-	5	-	5	-	5	-	5	-	4.6	-
tACK	Hold time for DMACK-	20	-	20	-	20	-	20	-	20	-	20	-
tIORDYZ	Maximum time before releasing IORDY	-	20	-	20	-	20	-	20	-	20	-	20

Figure 42. Ultra DMA cycle timings (Host Terminating Read)

7.9.4 Device Terminating Read DMA

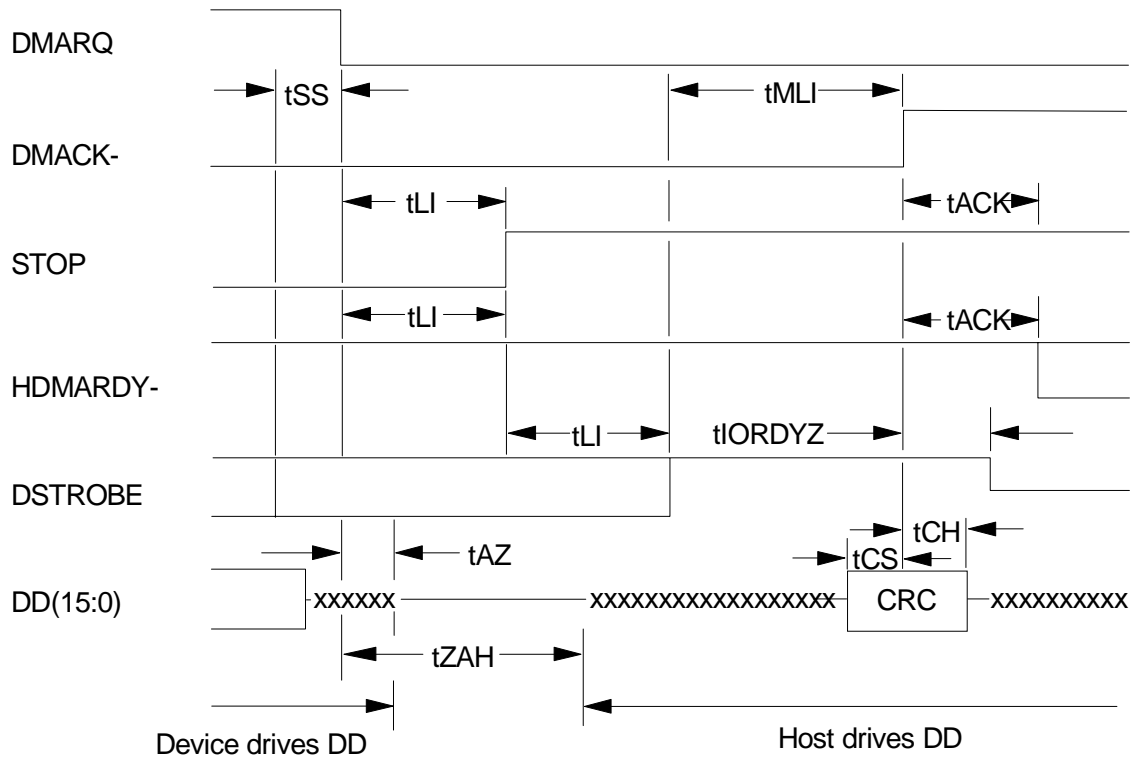

	PARAMETER DESCRIPTION	MODE 0		MODE 1		MODE 2		MODE 3		MODE 4		MODE 5	
		MIN (ns)	MAX (ns)	MIN (ns)	MAX (ns)	MIN (ns)	MAX (ns)	MIN (ns)	MAX (ns)	MIN (ns)	MAX (ns)	MIN (ns)	MAX (ns)
tSS	Time from DSTROBE edge to negation of DMARQ	50	–	50	–	50	–	50	–	50	–	50	–
tLI	Limited interlock time	0	150	0	150	0	150	0	100	0	100	0	75
tAZ	Maximum time allowed for output drivers to release	–	10	–	10	–	10	–	10	–	10	–	10
tZAH	Maximum delay time required for output	20	–	20	–	20	–	20	–	20	–	20	–
tMLI	Interlock time with minimum	20	–	20	–	20	–	20	–	20	–	20	–
tCS	CRC word setup time at device	15	–	10	–	7	–	7	–	5	–	4	–
tCH	CRC word hold time at device	5	–	5	–	5	–	5	–	5	–	4.6	–
tACK	Hold time for DMACK-	20	–	20	–	20	–	20	–	20	–	–	–
tIORDYZ	Maximum time before releasing IORDY	–	20	–	20	–	20	–	20	–	20	–	–

Figure 43. Ultra DMA cycle timings (Device Terminating Read)

7.9.5 Initiating Write DMA

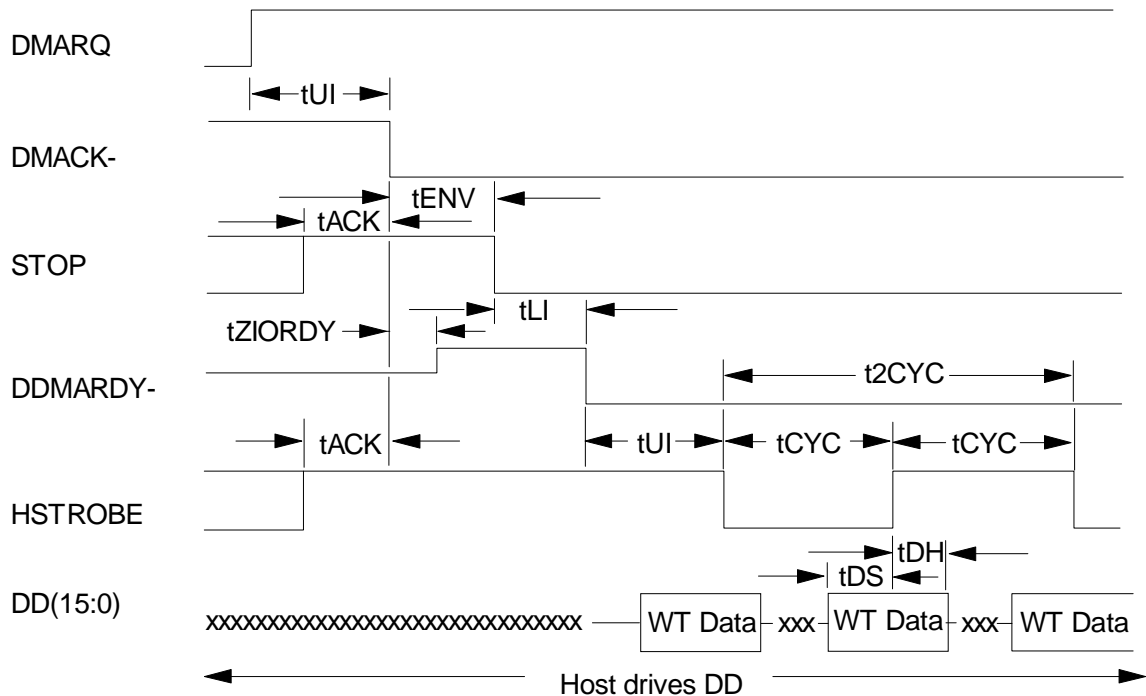

	PARAMETER DESCRIPTION	MODE 0		MODE 1		MODE 2		MODE 3		MODE 4		MODE 5	
		MIN (ns)	MAX (ns)	MIN (ns)	MAX (ns)	MIN (ns)	MAX (ns)	MIN (ns)	MAX (ns)	MIN (ns)	MAX (ns)	MIN (ns)	MAX (ns)
t_{UI}	Unlimited interlock time	0	–	0	–	0	–	0	–	0	–	0	–
t_{ACK}	Setup time for DMACK-	20	–	20	–	20	–	20	–	20	–	20	–
t_{ENV}	Envelope time	20	70	20	70	20	70	20	55	20	55	20	55
t_{ZIORDY}	Minimum time before driving IORDY	0	–	0	–	0	–	0	–	0	–	0	–
t_{LI}	Limited interlock time	0	150	0	150	0	150	0	100	0	100	0	75
t_{CYC}	Cycle time	112	–	73	–	54	–	39	–	25	–	16.8	–
t_{2CYC}	Two cycle time	230	–	154	–	115	–	86	–	57	–	38	–
t_{DS}	Data setup time at device	15	–	10	–	7	–	7	–	5	–	4	–
t_{DH}	Data Hold time at device	5	–	5	–	5	–	5	–	5	–	4.6	–

Figure 44. Ultra DMA cycle timings (Initiating Write)

7.9.6 Device Pausing Write DMA

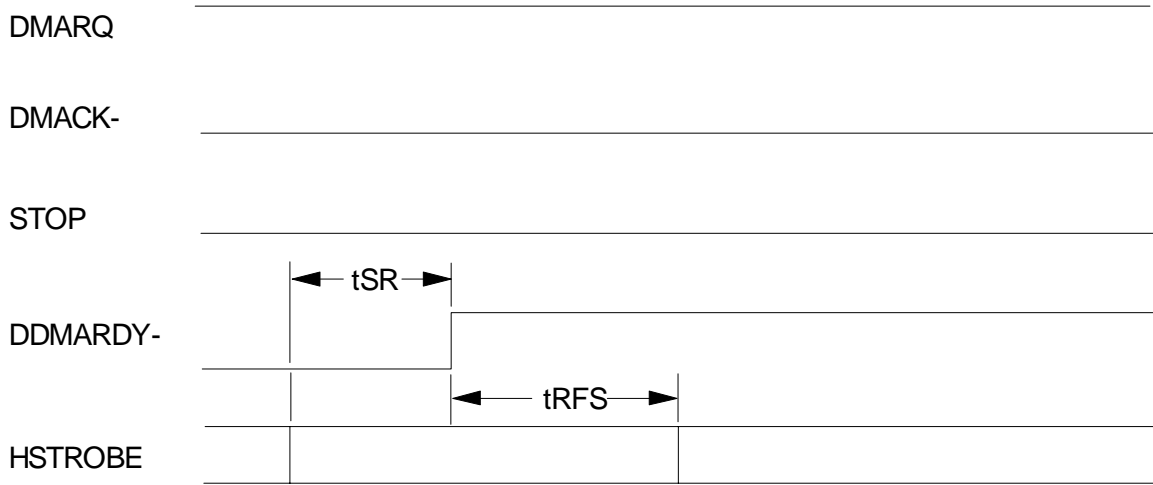

	PARAMETER DESCRIPTION	MODE 0		MODE 1		MODE 2		MODE 3		MODE 4		MODE 5	
		MIN (ns)	MAX (ns)	MIN (ns)	MAX (ns)	MIN (ns)	MAX (ns)	MIN (ns)	MAX (ns)	MIN (ns)	MAX (ns)	MIN (ns)	MAX (ns)
t_{SR}	HSTROBE to DDMARDY- time	-	50	-	30	-	20	-	-	-	-	-	-
t_{RFS}	DDMARDY- to final HSTROBE time	-	75	-	70	-	60	-	60	-	60	-	50

Note: When a device does not satisfy the t_{SR} timing, the device is ready to receive two more data words after DDMARDY- is negated.

Figure 45. Ultra DMA cycle timings (Device Pausing Write)

7.9.7 Device Terminating Write DMA

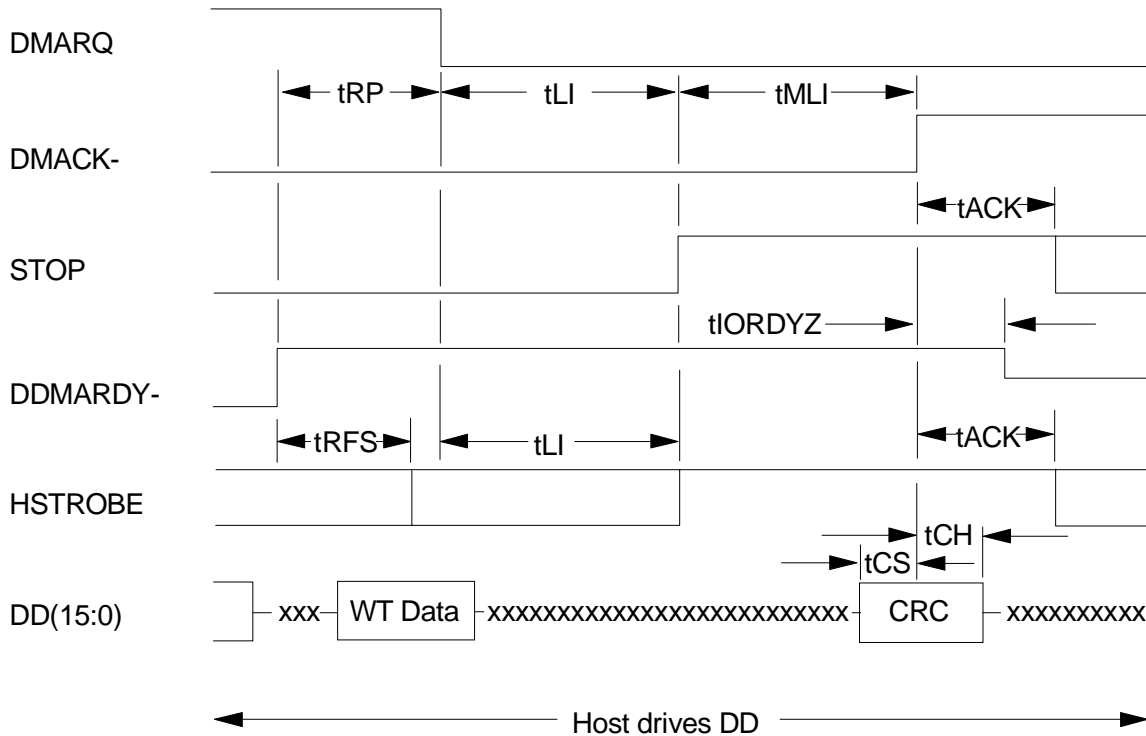

	PARAMETER DESCRIPTION	MODE 0		MODE 1		MODE 2		MODE 3		MODE 4		MODE 5	
		MIN (ns)	MAX (ns)	MIN (ns)	MAX (ns)	MIN (ns)	MAX (ns)	MIN (ns)	MAX (ns)	MIN (ns)	MAX (ns)	MIN (ns)	MAX (ns)
tRFS	DDMARDY- to final HSTROBE time	-	75	-	70	-	60	-	60	-	60	-	50
tRP	Ready to pause time	160	-	125	-	100	-	100	-	100	-	85	-
tLI	Limited interlock time	0	150	0	150	0	150	0	100	0	100	0	75
tMLI	Interlocking time with minimum	20	-	20	-	20	-	20	-	20	-	20	-
tCS	CRC word setup time at device	15	-	10	-	7	-	7	-	5	-	4	-
tCH	CRC word hold time at device	5	-	5	-	5	-	5	-	5	-	4.6	-
tACK	Hold time for DMACK-	20	-	20	-	20	-	20	-	20	-	20	-
tIORDYZ	Maximum time before releasing IORDY	-	20	-	20	-	20	-	20	-	20	-	20

Figure 46. Ultra DMA cycle timings (Device Terminating Write)

7.9.8 Host Terminating Write DMA

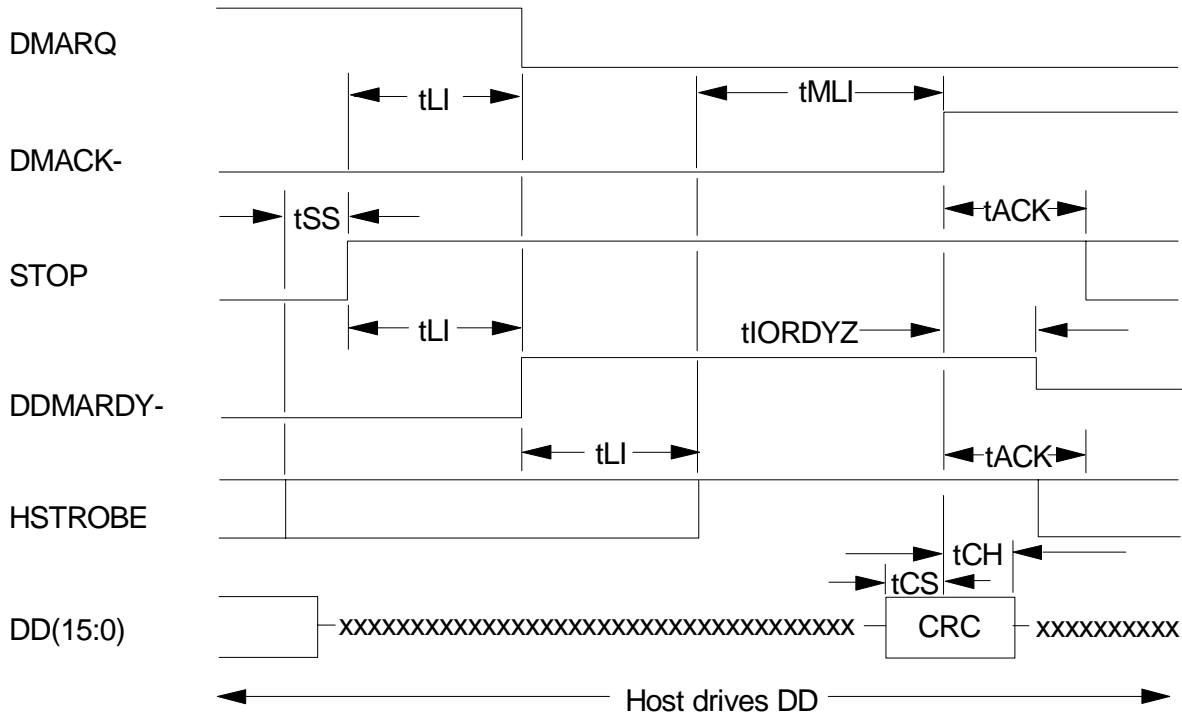

	PARAMETER DESCRIPTION	MODE 0		MODE 1		MODE 2		MODE 3		MODE 4		MODE 5	
		MIN (ns)	MAX (ns)	MIN (ns)	MAX (ns)	MIN (ns)	MAX (ns)	MIN (ns)	MAX (ns)	MIN (ns)	MAX (ns)	MIN (ns)	MAX (ns)
t_{SS}	Time from HSTROBE edge to assertion of STOP	50	-	50	-	50	-	50	-	50	-	50	-
t_{LI}	Limited interlock time	0	150	0	150	0	150	0	100	0	100	0	75
t_{MLI}	Interlock time with minimum	20	-	20	-	20	-	20	-	20	-	20	-
t_{CS}	CRC word setup time at device	15	-	10	-	7	-	7	-	5	-	4	-
t_{CH}	CRC word hold time at device	5	-	5	-	5	-	5	-	5	-	4.6	-
t_{ACK}	Hold time for DMACK-	20	-	20	-	20	-	20	-	20	-	20	-
t_{IORDYZ}	Maximum time before releasing IORDY	-	20	-	20	-	20	-	20	-	20	-	20

Figure 47. Ultra DMA cycle timings (Host Terminating Write)

7.10 Drive address setting

A jumper placed on the interface connector determines the drive address. The three drive addresses are shown below.

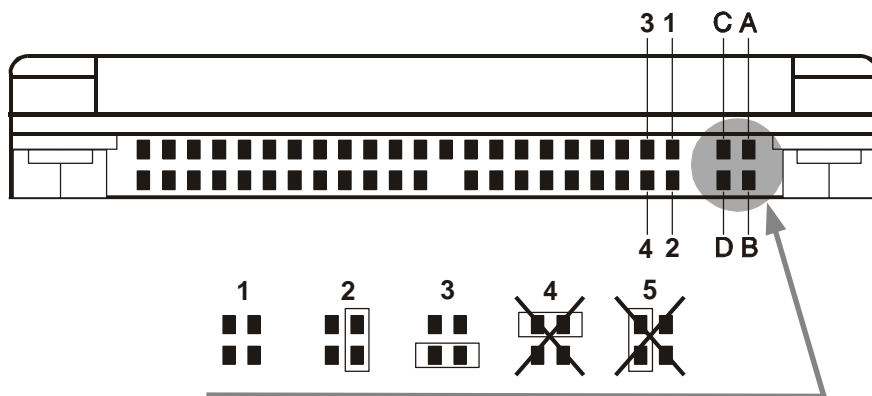

Figure 48. Drive address setting

- Setting 1—Device 0 (Master) (no jumper is used)
- Setting 2—Device 1 (Slave)
- Setting 3—Cable Select
- Setting 4—Never attach a jumper here
- Setting 5—Never attach a jumper here

When pin C is grounded, the drive does not spin up at POR.

When the drive address is Cable Select, the address depends on the condition of pin 28 of the AT interface cable. If pin 28 is ground (or low), the drive is a Master. If pin 28 is open (or logic high), the drive is a Slave.

7.10.1 Drive default address setting

The default setting of jumper at shipment is Setting 1: no jumper.

7.11 Addressing of HDD registers

The host addresses the drive through a set of registers called a Task File. These registers are mapped into the host's I/O space. Two chip select lines (CS0- and CS1-) and three address lines (DA00–02) are used to select one of these registers, while a DIOR- or DIOW- is provided at the specified time.

The chip select line CS0- is used to address the Command Block registers while the CS1- is used to address Control Block registers.

The following table shows the I/ O address map.

CS0-	CS1-	DA02	DA01	DA00	DIOR- = 0 (Read)	DIOW- = 0 (Write)
					Command Block Registers	
0	1	0	0	0	Data Reg.	Data Reg.
0	1	0	0	1	Error Reg.	Features Reg.
0	1	0	1	0	Sector count Reg.	Sector count Reg.
0	1	0	1	1	Sector number Reg.	Sector number Reg.
0	1	1	0	0	Cylinder low Reg.	Cylinder low Reg.
0	1	1	0	1	Cylinder high Reg.	Cylinder high Reg.
0	1	1	1	0	Drive/Head Reg.	Drive/Head Reg.
0	1	1	1	1	Status Reg.	Command Reg.
					Control Block Registers	
1	0	1	1	0	Alt. Status Reg.	Device control Reg.
1	0	1	1	1	Drive address Reg.	–

Figure 49. I/O address map

This page intentionally left blank.

Part 2. Interface specification

This page intentionally left blank.

8.0 General

8.1 Introduction

This specification describes the host interface of the Travelstar 60GH & 40GN.

The interface conforms to the Working Document of Information technology, AT Attachment with Packet Interface Extension (ATA/ATAPI-5) Revision 3, dated 29 February 2000, with certain limitations described in section 9.0, "Deviations From Standard" on page 65.

The drive supports the following new functions included by ATA/ATAPI-5 standards or newer standards:

- Device Configuration Overlay

The drive supports the following functions as Vendor Specific Functions:

- Address Offset Feature
- Format Unit Function
- ENABLE/DISABLE DELAYED WRITE
- SENSE CONDITION command

8.2 Terminology

Device	The Travelstar 60GH & 40GN drive
Host	The system to which the device is attached
First Command	The first command which is executed after the power on reset (also known as a hard reset) is the Standby mode command.
INTRQ	Interrupt request (Device or Host)

This page intentionally left blank.

9.0 Deviations from standard

The device conforms to the referenced specifications, with deviations described below.

The interface conforms to the Working Document of Information Technology, AT Attachment with Packet Interface Extension (ATA/ATAPI-5) Revision 3, dated 29 February 2000, with the following deviation:

Standby Timer	Standby timer is enabled by STANDBY command or IDLE command. The value in the Sector Count register shall be used to determine the time programmed into the Standby timer. If the Sector Count register is zero, the Standby timer is automatically set to 109 minutes.
Write Verify	WRITE VERIFY command does not include read verification after write operation. The function is the same as WRITE SECTORS command.
S.M.A.R.T. Return Status	S.M.A.R.T. RETURN STATUS subcommand does not check advisory attributes. This means that the device will not report a threshold exceeded condition unless the prefailure attributes exceed their corresponding thresholds. For example, a Power-On Hours Attribute never results in a negative reliability status.

This page intentionally left blank.

10.0 Registers

Addresses					Functions	
CS0-	CS1-	DA2	DA1	DA0	READ (DIOR-)	WRITE (DIOW-)
N	N	x	x	x	Data bus high impedance	Not used
					Control block registers	
N	A	0	x	x	Data bus high impedance	Not used
N	A	1	0	x	Data bus high impedance	Not used
N	A	1	1	0	Alternate Status	Device Control
N	A	1	1	1	Device Address	Not used
					Command block registers	
A	N	0	0	0	Data	Data
A	N	0	0	1	Error Register	Features
A	N	0	1	0	Sector Count	Sector Count
A	N	0	1	1	Sector Number	Sector Number
A	N	0	1	1	* LBA bits 0-7	* LBA bits 0-7
A	N	1	0	0	Cylinder Low	Cylinder Low
A	N	1	0	0	* LBA bits 8-15	* LBA bits 8-15
A	N	1	0	1	Cylinder High	Cylinder High
A	N	1	0	1	* LBA bits 16-23	* LBA bits 16-23
A	N	1	1	0	Device/Head.	Device/Head
A	N	1	1	0	* LBA bits 24-27	* LBA bits 24-27
A	N	1	1	1	Status	Command
A	A	x	x	x	Invalid address	Invalid address

Logic conventions: A = signal asserted
 N = signal not asserted
 x = either A or N

* = Mapping of registers in LBA mode

Figure 50. Register Set

Communication to or from the device is through an I/O Register that routes the input or output data to or from the registers addressed by the signals from the host (CS0-, CS1-, DA2, DA1, DA0, DIOR- and DIOW-).

The Command Block Registers are used for sending commands to the device or posting status from the device.

The Control Block Registers are used for device control and to post alternate status.

10.1 Alternate Status Register

Alternate Status Register							
7	6	5	4	3	2	1	0
BSY	RDY	DF	DSC	DRQ	COR	IDX	ERR

Figure 51. Alternate Status Register

This register contains the same information as the Status Register. The only difference between this register and the Status Register is that reading the Alternate Status Register does not imply an interrupt acknowledge or a clear of a pending interrupt. See 10.13, "Status Register" on page 70 for the definition of the bits in this register.

10.2 Command Register

This register contains the command code being sent to the device. Command execution begins immediately after this register is written. The command set is shown in Figure 72 on page 103. All other registers required for the command must be set up before writing to the Command Register.

10.3 Cylinder High Register

This register contains the high order bits of the starting cylinder address for any disk access. At the end of the command, this register is updated to reflect the current cylinder number.

In LBA Mode this register contains Bits 16–23. At the end of the command, this register is updated to reflect the current LBA Bits 16–23.

The cylinder number may be from zero to the number of cylinders minus one.

10.4 Cylinder Low Register

This register contains the low order 8 bits of the starting cylinder address for any disk access. At the end of the command, this register is updated to reflect the current cylinder number.

In LBA Mode this register contains Bits 8–15. At the end of the command, this register is updated to reflect the current LBA Bits 8–15.

The cylinder number may be from zero to the number of cylinders minus one (1).

10.5 Data Register

This register is used to transfer data blocks between the device data buffer and the host. It is also the register through which sector information is transferred on a Format Track command and the configuration information is transferred on an Identify Device command.

All data transfers are 16 bits wide, except for ECC byte transfers, which are 8 bits wide. Data transfers are PIO only.

The register contains valid data only when DRQ = 1 is in the Status Register.

10.6 Device Control Register

Drive Control Register							
7	6	5	4	3	2	1	0
-	-	-	-	1	SRST	-IEN	0

Figure 52. Device Control Register

Bit	Definitions
SRST	Software Reset. The device is held at reset when RST = 1. Setting RST = 0 again enables the device. To ensure that the device recognizes the reset, the host must set RST = 1 and wait for at least 5 μ s before setting RST = 0.
-IEN	Interrupt Enable. When IEN = 0, and the device is selected, the device interrupts to the host will be enabled. When IEN = 1, or the device is not selected, the device interrupts to the host will be disabled.

10.7 Drive Address Register

Drive Address Register							
7	6	5	4	3	2	1	0
HIZ	-WTG	-H3	-H2	-H1	-H0	-DS1	-DS0

Figure 53. Drive Address Register

This register contains the inverted drive select and head select addresses of the currently selected drive.

Bit Definitions

- HIZ** High Impedance. This bit is not a device and will always be in a high impedance state.
- WTG** -Write Gate. This bit is 0 when writing to the disk device is in progress.
- H3, -H2, -H1, -H0** -Head Select. These four bits are the one's complement of the binary coded address of the currently selected head. Bit -H0 is the least significant.
- DS1** -Drive Select 1. The Drive Select bit for device 1 is active low. DS1 = 0 when device 1 (slave) is selected and active.
- DS0** -Drive Select 0. The Drive Select bit for device 0 is active low. DS0 = 0 when device 0 (master) is selected and active.

10.8 Device/Head Register

Device/Head Register							
7	6	5	4	3	2	1	0
1	L	1	DRV	HS3	HS2	HS1	HS0

Figure 54. Device/Head Register

This register contains the device and head numbers.

Bit Definitions

- L** Binary encoded address mode select. When L = 0, addressing is by CHS mode. When L = 1, addressing is by LBA mode.
- DRV** Device. When DRV = 0, device 0 (master) is selected. When DRV = 1, device 1 (Slave) is selected.
- HS3, HS2, HS0** Head Select. These four bits indicate the binary encoded address of the head. Bit HS0 is the least significant bit. At command completion, these bits are updated to reflect the currently selected head. The head number may be from zero to the number of heads minus one. In LBA mode, HS3 through HS0 contain bits 24–27 of the LBA. At command completion, these bits are updated to reflect the current LBA bits 24–27.

10.9 Error Register

Error Register							
7	6	5	4	3	2	1	0
CRC	UNC	0	IDNF	0	ABRT	TK0NF	AMNF

Figure 55. Error Register

This register contains the status from the last command executed by the device or a diagnostic code. At the completion of any command, except Execute Device Diagnostic, the contents of this register are always valid even if ERR = 0 is in the Status Register.

Following a power on, a reset, or completion of an Execute Device Diagnostic command, this register contains a diagnostic code. See Figure 59 on page 73 for the definitions.

Bit Definitions

- ICRCE (CRC)** Interface CRC Error. When CRC = 1, it indicates that a CRC error has occurred on the data bus during a Ultra DMA transfer.
- UNC** Uncorrectable Data Error. When UNC = 1 it indicates that an uncorrectable data error has been encountered.
- IDNF (IDN)** ID Not Found. When IDN = 1, it indicates that the requested sector's ID field could not be found.
- ABRT (ABT)** Aborted Command. When ABT = 1, it indicates that the requested command has been aborted due to a device status error or an invalid parameter in an output register.
- TK0NF (T0N)** Track 0 Not Found. When T0N = 1, it indicates that track 0 was not found during a Recalibrate command.
- AMNF (AMN)** Address Mark Not Found. When AMN = 1, it indicates that the data address mark has not been found after finding the correct ID field for the requested sector.
-

10.10 Features Register

This register is command specific. This register is used with the Set Features command, the S.M.A.R.T. Function Set command, and the Format Unit command.

10.11 Sector Count Register

This register contains the number of sectors of data requested to be transferred on a read or write operation between the host and the device. If the value in the register is set to 0, a count of 256 sectors is specified.

If the register is zero at command completion, the command was successful. If it is not successfully completed, the register contains the number of sectors which need to be transferred in order to complete the request.

The contents of the register are defined differently on some commands. These definitions are given in section 13.0, "Command descriptions" on 103.

10.12 Sector Number Register

This register contains the starting sector number for any disk data access for the subsequent command. The sector number is from one to the maximum number of sectors per track.

In LBA mode, this register contains Bits 0–7. At the end of the command, this register is updated to reflect the current LBA Bits 0–7.

10.13 Status Register

Status Register							
7	6	5	4	3	2	1	0
BSY	DRDY	DF	DSC	DRQ	COR	IDX	ERR

Figure 56. Status Register

This register contains the device status. The contents of this register are updated whenever an error occurs and at the completion of each command.

If the host reads this register when an interrupt is pending, it is considered to be the interrupt acknowledge. Any pending interrupt is cleared whenever this register is read.

If BSY=1, no other bits in the register are valid.

Bit Definitions

- BSY** Busy. Bit BSY=1 whenever the device is accessing the registers. The host should not read or write any registers when BSY=1. If the host reads any register when BSY=1, the contents of the Status Register will be returned.
- DRDY (RDY)** Device Ready. When bit RDY=1 it indicates that the device is capable of responding to a command. Bit RDY will be set to 0 during power on until the device is ready to accept a command.
- DF** Device Fault. If DF=1 it indicates that the device has detected a write fault condition. Bit DF is set to 0 after the Status Register is read by the host.
- DSC** Device Seek Complete. If DSC=1, it indicates that a Seek has completed and the device head is settled over a track. Bit DSC is set to 0 by the device just before a Seek begins. When an error occurs, this bit is not changed until the Status Register is read by the host and at that time the bit again indicates the current Seek complete status. When the device enters into or is in Standby mode or Sleep mode, this bit is set by device in spite of the drive not spinning up.
- DRQ** Data Request. Bit DRQ=1 indicates that the device is ready to transfer a word or byte of data between the host and the device. The host should not write the Command register when DRQ=1.
- CORR (COR)** Corrected Data. Always 0.
- IDX** Index. Bit IDX=1 once per revolution. Since IDX=1, only for a very short time during each revolution, the host may not see it set to 1 even if the host is reading the Status Register continuously. Therefore the host should not attempt to use IDX bit for timing purposes.
- ERR** Error. Bit ERR=1 indicates that an error occurred during execution of the previous command. The Error Register should be read to determine the error type. The device sets bit ERR=0 when the next command is received from the host.

11.0 General operation descriptions

11.1 Reset response

ATA has the following three types of resets:

- Power On Reset (POR)** The device executes a series of electrical circuitry diagnostics, spins up the head disk assembly, tests speed and other mechanical parametric, and sets default values.
- Hard Reset (Hardware Reset)** The RESET signal is negated in the ATA Bus. The device resets the interface circuitry and sets the default values.
- Soft Reset (Software Reset)** The SRST bit in the Device Control Register is set and then is reset. The device resets the interface circuitry according to the Set Features requirement.

The actions of each reset are shown in Figure 57 on page 72.

	POR	hard reset	soft reset
Aborting Host interface	-	o	o
Aborting Device operation	-	(*1)	(*1)
Initialization of hardware	o	x	x
Internal diagnostic	o	x	x
Starting or Spinning Up spindle motor	(*6)	x	x
Initialization of registers (*2)	o	o	o
DASP- handshake	o	o	x
PDIAG- handshake	o	o	o
Reverting programmed parameters to default <ul style="list-style-type: none"> • Number of CHS (set by Initialize Device Parameters) • Multiple mode • Write Cache • Delayed Write • Read look-ahead • ECC bytes • Volatile max. Address • Address offset mode 	o	o	(*3)
Power mode	(*6)	(*4)	(*4)
Reset Standby timer value (*5)	o	o	o

o—execute

x—does not execute

Notes.

- (*1). *Execute after the data in write cache has been written.*
- (*2). *The default value on POR is shown in Figure 58 on page 73.*
- (*3). *The Set Features command with Feature register = CCh enables the device to revert these parameters to the power on defaults.*
- (*4). *In the case of sleep mode, the device goes to standby mode. In other cases, the device does not change current mode.*
- (*5). *After reset the Standby timer value is set to 109 minutes.*
- (*6). *Set according to the initial power mode selection.*

Figure 57. Reset response table

11.2 Register initialization

After a power on, a hard reset, or a software reset, the register values are initialized as shown in the table below.

Register	Default Value
Error	Diagnostic Code
Sector Count	01h
Sector Number	01h
Cylinder Low	00h
Cylinder High	00h
Device/Head	A0h
Status	50h
Alternate Status	50h

Figure 58. Default Register Values

If an Execute Device Diagnostic command is carried out, if the system is powered on, or if a hard reset occurs, the system generates an Error Register diagnostic code. See the table below for a description of the codes.

Code	Description
01h	No error detected
02h	Formatter device error
03h	Sector buffer error
04h	ECC circuitry error
05h	Controller microprocessor error
8xh	Device 1 failed

Figure 59. Diagnostic Codes

11.3 Diagnostic and Reset considerations

The Set Max password, the Set Max security mode and the Set Max unlock counter are not retained over a Power On Reset but are retained over a Hard Reset or Soft Reset.

For each Reset and Execute Device Diagnostic, the diagnostic is done as follows:

Power On Reset, Hard Reset	DASP– is read by Device 0 to determine if Device 1 is present. If Device 1 is present Device 0 shall read PDIAG– to determine when it is valid to clear the BSY bit and whether Device 1 has powered on or reset without error, otherwise Device 0 clears the BSY bit whenever it is ready to accept commands. Device 0 may assert DASP– to indicate device activity. If Device 1 is not present, Device 0 does not Assert DASP– at POR.
Soft Reset	If Device 1 is present, Device 0 shall read PDIAG– to determine when it is valid to clear the BSY bit and whether Device 1 has reset without any errors; otherwise, Device 0 shall simply reset and clear the BSY bit. DASP– is asserted by Device 0 (and Device 1 if it is present) in order to indicate device active.
Execute Device Diagnostic	If Device 1 is present, Device 0 shall read PDIAG– to determine when it is valid to clear the BSY bit and if Device 1 passed or failed the EXECUTE DEVICE DIAGNOSTIC command; otherwise, Device 0 shall simply execute its diagnostics and then clear the BSY bit. DASP– is asserted by Device 0 (and Device 1 if it is present) in order to indicate that the device is active.

In each case – **Power On Reset [Hard Reset]**, **Soft Reset**, and the **Execute Device Diagnostic** command – the Device 0 Error register value is interpreted using the table below.

Device 1 present?	PDIAG-Asserted?	Device 0 Passed	Error Register
Yes	Yes	Yes	01h
Yes	Yes	No	0xh
Yes	No	Yes	81h
Yes	No	No	8xh
No	(not read)	Yes	01h
No	(not read)	No	0xh

The "x" indicates the appropriate Diagnostic Code for the Power on, RESET-, Soft Reset, or Device Diagnostic error.

Figure 60. Reset error register values

11.4 Power-off considerations

11.4.1 Load/Unload

Load/Unload is a functional mechanism of the hard disk drive. It is controlled by the drive microcode. Specifically, unloading of the heads is invoked by the following commands.

Command	Response
Standby	UL -> Comp.
Standby Immediate	UL -> Comp.
Sleep	UL -> Comp.

Reset	Response
Soft Reset	Rdy (*1)
Hard Reset	UL -> Rdy

UL = unload
Comp = complete
Rdy = interface ready
(*1) Load/Unload condition is not changed by Soft Reset

Figure 61. Device behavior by ATA commands.

Load is also invoked as the idle command.

The specified start/stop life of the product assumes that load/unload is operated normally, NOT in emergency mode.

11.4.2 Emergency unload

When the drive power is interrupted with the heads still loaded, the microcode cannot operate and the normal 5V power is unavailable to unload the heads. In this case, normal unload is not possible, so the heads are unloaded by routing the back EMF of the spinning motor to the voice coil. The actuator velocity is greater than the normal case, and the unload process is inherently less controllable without a normal seek current profile.

Emergency unload is intended to be invoked in rare situations. Because this operation is inherently uncontrolled, it is more mechanically stressful than a normal unload.

A single emergency unload operation is more stressful than 100 normal unloads. Use of emergency unload reduces the start/stop life of the drive at a rate at least 100 times faster than that of normal unload and may damage the drive.

11.4.3 Required power-off sequence

When power is removed on most drives at an arbitrary time, problems can result. The following are examples of such problems:

- Data is lost from the write buffer
- If the drive is writing a sector, a partially-written sector with an incorrect ECC block results, the sector contents are destroyed, and reading that sector results in a hard error
- Heads may land in the data zone instead of the landing zone depending on the design of the drive

You may then turn off the drive in the following order:

1. Issue Standby Immediate or sleep command
2. Wait until COMMAND COMPLETE STATUS is returned. (It may take up to 350 ms in a typical case.)
3. Terminate power to drive

This power-down sequence should be followed for entry into any system power-down state, system suspend state, or system hibernation state. In a robustly designed system, emergency unload is limited to rare scenarios such as battery removal during operation.

11.5 Sector Addressing Mode

All addressing of data sectors recorded on the device's media is done by a logical sector address. The logical CHS address for the drive is different from the actual physical CHS location of the data sector on the disk media.

The drive supports both Logical CHS Addressing Mode and LBA Addressing Mode as the sector addressing mode.

The host system may select either the currently selected CHS translation addressing or LBA addressing on a command-by-command basis by using the L bit in the DEVICE/HEAD register. A host system must set the L bit to 1 if the host uses LBA Addressing mode.

11.5.1 Logical CHS addressing mode

The logical CHS addressing is made up of three fields: the cylinder number, the head number, and the sector number. Sectors are numbered from 1 to the maximum value allowed by the current CHS translation mode but cannot exceed 255 (0FFh). Heads are numbered from 0 to the maximum value allowed by the current CHS translation mode but cannot exceed 15 (0Fh). Cylinders are numbered from 0 to the maximum value allowed by the current CHS translation mode but cannot exceed 65535 (0FFFFh).

When the host selects a CHS translation mode using the INITIALIZE DEVICE PARAMETERS command, the host requests the number of sectors per logical track and the number of heads per logical cylinder. The device then computes the number of logical cylinders available in requested mode.

The default CHS translation mode is described in the Identify Device Information. The current CHS translation mode also is described in the Identify Device Information.

11.5.2 LBA addressing mode

Logical sectors on the device shall be linearly mapped with the first LBA addressed sector (sector 0) being the same sector as the first logical CHS addressed sector (cylinder 0, head 0, sector 1). Irrespective of the logical CHS translation mode currently in effect, the LBA address of a given logical sector does not change. The following formula is always true:

$$\text{LBA} = ((\text{cylinder} \times \text{heads_per_cylinder} + \text{heads}) \times \text{sectors_per_track}) + \text{sector} - 1$$

where heads_per_cylinder and sectors_per_track are the current translation mode values.

On LBA addressing mode, the LBA value is set to the following register:

Device/Head	<- - - LBA bits 27–24
Cylinder High	<- - - LBA bits 23–16
Cylinder Low	<- - - LBA bits 15–8
Sector Number	<- - - LBA bits 7–0

11.6 Power management features

The power management feature set permits a host to modify the behavior in a manner which reduces the power required to operate. The power management feature set provides a set of commands and a timer that enables a device to implement low power consumption modes.

The drive implements the following set of functions:

1. A Standby timer
2. Idle command
3. Idle Immediate command
4. Sleep command
5. Standby command
6. Standby Immediate command

11.6.1 Power Mode

Sleep Mode	The lowest power consumption when the device is powered on occurs in Sleep Mode. When in sleep mode, the device requires a reset to be activated.
Standby Mode	The device interface is capable of accepting commands, but since the media may not be immediately accessible, there is a delay while waiting for the spindle to reach operating speed.
Idle Mode	All electronic components remain powered and full frequency servo remains operational.
Active Mode	The device is in execution of a command or accessing the disk media with the read look-ahead function or the write cache function.

11.6.2 Power management commands

The Check Power Mode command allows a host to determine if a device is currently in, going to, or leaving standby mode.

The Idle and Idle Immediate commands move a device to idle mode immediately from the active or standby modes. The idle command also sets the standby timer count and starts the standby timer.

The sleep command moves a device to sleep mode. The device's interface becomes inactive at the completion of the sleep command. A reset is required to move a device out of sleep mode. When a device exits sleep mode it will enter standby mode.

The Standby and Standby Immediate commands move a device to standby mode immediately from the active or idle modes. The standby command also sets the standby timer count.

11.6.3 Standby/Sleep command completion timing

1. Confirm the completion of writing cached data in the buffer to media.
2. Unload the heads on the ramp.
3. Set the DRDY bit and the DSC bit in Status Register.
4. Set the INTRQ (completion of the command).
5. Activate the spindle break to stop the spindle motor.
6. Wait until the spindle motor is stopped.
7. Perform the post process.

11.6.4 Standby timer

The standby timer provides a method for the device to automatically enter standby mode from either active or idle mode following a host programmed period of inactivity. If the device is in the active or idle mode, the device waits for the specified time period and if no command is received, the device automatically enters the standby mode.

If the value of the SECTOR COUNT register on Idle command or the Standby command is set to "00h", the device will automatically set the standby timer to 109 minutes.

11.6.5 Status

In the active, idle, and standby modes, the device shall have the RDY bit of the status register set. If the BSY bit is not set, the device shall be ready to accept any command.

In sleep mode, the device's interface is not active. A host shall not attempt to read the status of the device or issue commands to the device.

11.6.6 Interface Capability for Power Modes

Each power mode affects the physical interface as defined in the following table:

Mode	BSY	RDY	Interface active	Media
Active	x	x	Yes	Active
Idle	o	1	Yes	Active
Standby	o	1	Yes	Inactive
Sleep	x	x	No	Inactive

Figure 62. Power conditions

Ready (RDY) is not a power condition. A device may post ready at the interface even though the media may not be accessible.

The interface is inactive in sleep mode, but the access to the interface registers and the validity of INTRQ is guaranteed for two seconds after the Sleep command is completed. After this period, the contents of interface registers may be lost. Since the contents of interface registers may be invalid, the host should NOT check the Status register nor the Alternate Status register prior to issuing a soft reset to wake up a device.

11.6.7 Initial Power Mode at Power On

After power on or hard reset the device goes to IDLE mode or STANDBY mode depending on the option. Refer to section 4.4.3, "Operating Modes" on page 17 for the initial power mode selection.

11.7 S.M.A.R.T. Function

The intent of Self-monitoring, analysis, and reporting technology (S.M.A.R.T.) is to protect user data and prevent unscheduled system downtime that may be caused by predictable degradation and/or fault of the device. By monitoring and storing critical performance and calibration parameters, S.M.A.R.T. devices employ sophisticated data analysis algorithms to predict the likelihood of near-term degradation or fault condition. By alerting the host system of a negative reliability status condition, the host system can warn the user of the impending risk of a data loss and advise the user of appropriate action.

Since S.M.A.R.T. utilizes the internal device microprocessor and other device resources, there may be some small overhead associated with its operation. However, special care has been taken in the design of the S.M.A.R.T. algorithms to minimize the impact to host system performance. Actual impact of S.M.A.R.T. overhead is dependent on the specific device design and the usage patterns of the host system. To further ensure minimal impact to the user, S.M.A.R.T. capable devices are shipped from the device manufacturer's factory with the S.M.A.R.T. feature disabled. S.M.A.R.T. capable devices can be enabled by the system OEMs at time of system integration or in the field by after-market products.

11.7.1 Attributes

Attributes are the specific performance or calibration parameters that are used in analyzing the status of the device. Attributes are selected by the device manufacturer based on that attribute's ability to contribute to the prediction of degrading or faulty conditions for that particular device. The specific set of attributes being used and the identity of these attributes is vendor specific and proprietary.

11.7.2 Attribute values

Attribute values are used to represent the relative reliability of individual performance or calibration attributes. Higher attribute values indicate that the analysis algorithms being used by the device are predicting a lower probability of a degrading or fault condition existing. Accordingly, lower attribute values indicate that the analysis algorithms being used by the device are predicting a higher probability of a degrading or fault condition existing. There is no implied linear reliability relationship corresponding to the numerical relationship between different attribute values for any particular attribute.

11.7.3 Attribute thresholds

Each attribute value has a corresponding attribute threshold limit which is used for direct comparison to the attribute value to indicate the existence of a degrading or faulty condition. The numerical value of the attribute thresholds are determined by the device manufacturer through design and reliability testing and analysis. Each attribute threshold represents the lowest limit to which its corresponding attribute value can be equal while still retaining a positive reliability status. Attribute thresholds are set at the device manufacturer's factory and cannot be changed in the field. The valid range for attribute thresholds is from 1 through 253 decimal.

11.7.4 Threshold exceeded condition

If one or more attribute values are less than or equal to their corresponding attribute thresholds, then the device reliability status is negative, indicating an impending degrading or faulty condition.

11.7.5 S.M.A.R.T. commands

The S.M.A.R.T. commands provide access to attribute values, attribute thresholds and other logging and reporting information.

11.7.6 S.M.A.R.T. operation with power management modes

The device saves attribute values automatically on every head unload timing except the emergency unload, even if the attribute auto save feature is not enabled. The head unload is done not only by Standby, Standby Immediate, Sleep command, and Hard Reset, but also by the Standby timer. So it is not necessary for a host system to enable the attribute auto save feature when it utilizes the power management. If the attribute auto save feature is enabled, attribute values will be saved after 30 minutes have passed since the last saving, besides above condition.

11.8 Security Mode Feature Set

Security Mode Feature Set is a powerful security feature. With a device lock password, a user can prevent unauthorized access to a device even if it is removed from the computer.

New commands are supported for this feature as listed below:

Security Set Password	('F1'h)
Security Unlock	('F2'h)
Security Erase Prepare	('F3'h)
Security Erase Unit	('F4'h)
Security Freeze Lock	('F5'h)
Security Disable Password	('F6'h)

11.8.1 Security Mode

The following security modes are provided.

Device Locked Mode	The device disables media access commands after power on. Media access commands are enabled by either a Security Unlock command or a Security Erase Unit command.
Device Unlocked Mode	The device enables all commands. If a password is not set this mode is entered after power on, otherwise it is entered by a Security Unlock or a Security Erase Unit command.
Device Frozen Mode	The device enables all commands except those which can update the device lock function, set/change password. The device enters this mode via a Security Freeze Lock command. It cannot quit this mode until power off.

11.8.2 Security level

The following security levels are provided:

High level security	When the device lock function is enabled and the User Password is forgotten, the device can be unlocked via a Master Password.
Maximum level security	When the device lock function is enabled and the User Password is forgotten, then only the Master Password with a Security Erase Unit command can unlock the device. Then user data is erased.

11.8.3 Password

This function can have two types of passwords as described below.

Master Password	When the Master Password is set, the device does NOT enable the Device Lock Function, and the device CANNOT be locked with the Master Password, but the Master Password can be used for unlocking the locked device.
User Password	The User Password should be given or changed by a system user. When the User Password is set, the device enables the Device Lock Function, and then the device is locked on the next power on reset or hard reset.

The system manufacturer or dealer who intends to enable the device lock function for end users must set the master password even if only single level password protection is required. Otherwise, the 'default' master password which is set by IBM can unlock a device that is locked with a user password.

11.8.4 Master Password Revision Code

This Master Password Revision Code is set by Security Set Password command with the master password. And this revision code field is returned in the Identify Device command word 92. The valid revision codes are 0001h to FFFEh. The default value of Master Password Revision Code is FFFEh. Values 0000h and FFFFh are reserved.

11.8.5 Operation example

11.8.5.1 Master Password setting

The system manufacturer or dealer can set an initial Master Password using the Security Set Password command, without enabling the Device Lock Function.

11.8.5.2 User Password setting

When a User Password is set, the device will automatically enter lock mode the next time the device is powered on.

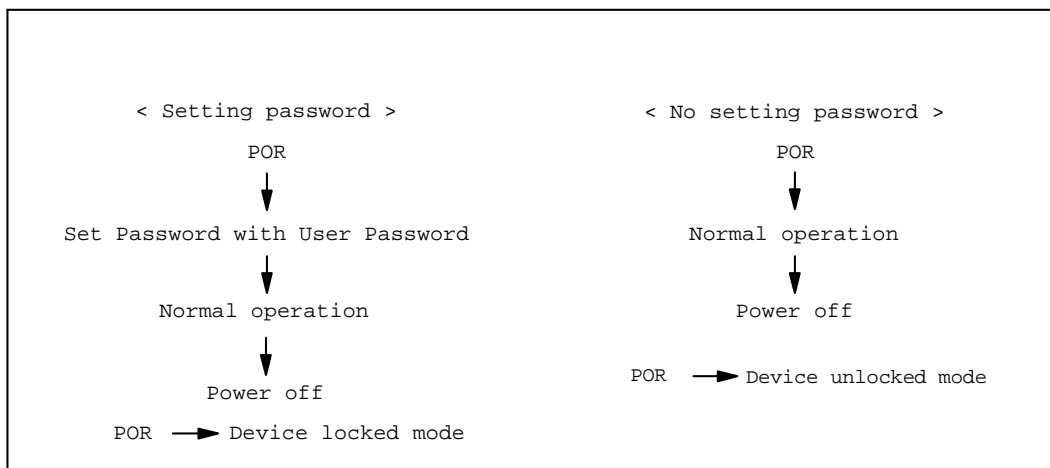
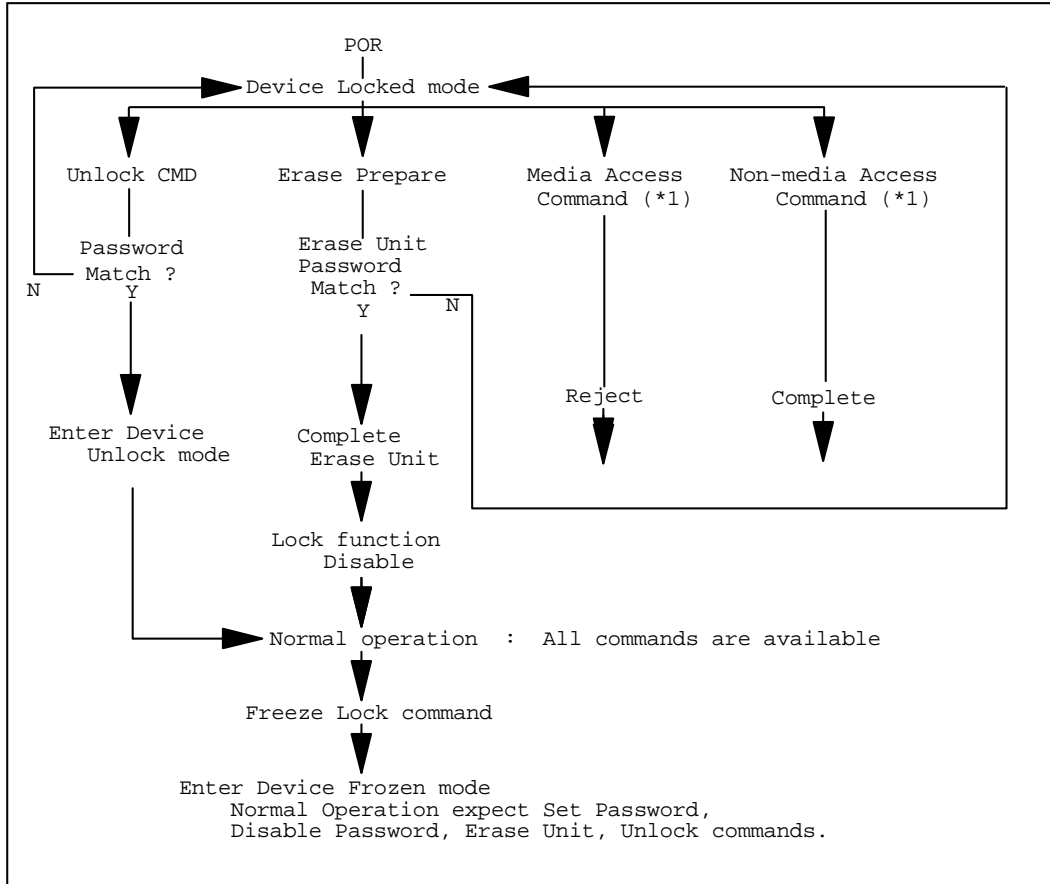

Figure 63. Initial setting

11.8.5.3 Operation from POR after user password is set

When Device Lock Function is enabled, the device rejects media access command until a Security Unlock command is successfully completed.



(*1) — refers to the commands in Figure 66, "Command table for device lock operation" on pages 86 and 87.

Figure 64. Usual operation for POR

11.8.5.4 User Password lost

If the User Password is forgotten and High level security is set, the system user cannot access any data. However the device can be unlocked using the Master Password.

If a system user forgets the User Password and Maximum security level is set, data access is impossible. However the device can be unlocked using the Security Erase Unit command to unlock the device and erase all user data with the Master Password.

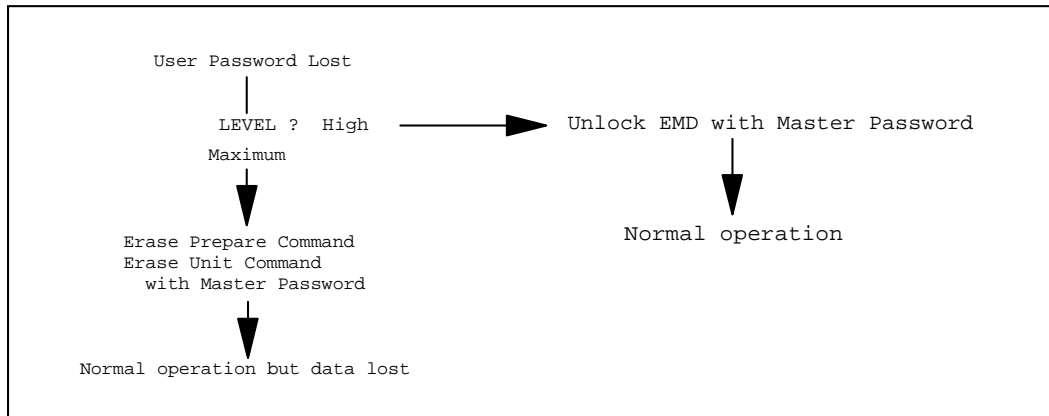

Figure 65. Password lost

11.8.5.5 Attempt limit for the SECURITY UNLOCK command

The SECURITY UNLOCK command has an attempt limit the purpose of which is to prevent someone from attempting to unlock the drive with various passwords numerous times.

The device counts the password mismatch. If the password does not match, the device counts it without distinguishing the Master password and the User password. If the count reaches 5, EXPIRE bit (bit 4) of Word 128 in Identify Device information is set, and then the SECURITY ERASE UNIT command and the SECURITY UNLOCK command are aborted until a hard reset or a power off. The count and EXPIRE bit are cleared after a power on reset or a hard reset.

11.8.6 Command table

This table shows the device's response to commands when the Security Mode Feature Set (Device lock function) is enabled.

The head unload is done not only by Standby, Standby Immediate, Sleep command and Hard Reset, but also by the Standby timer.

Command	Device Locked Mode	Device Unlocked Mode	Device Frozen Mode
Check Power Mode	0	0	0
Enable/Disable Delayed Write	0	0	0
Device Configuration RESTORE	x	0	0
Device Configuration FREEZE LOCK	0	0	0
Device Configuration IDENTIFY	0	0	0
Device Configuration SET	x	0	0
Execute Device Diagnostic	0	0	0
Flush Cache	0	0	0
Format Track	x	0	0
Format Unit	x	0	0
Identify Device	0	0	0
Idle	0	0	0
Idle Immediate	0	0	0
Initialize Device Parameters	0	0	0
Read Buffer	0	0	0
Read DMA	x	0	0
Read Long	x	0	0
Read Multiple	x	0	0
Read Native Max ADDRESS	0	0	0
Read Sector(s)	x	0	0
Read Verify Sector(s)	x	0	0
Recalibrate	0	0	0
Security Disable Password	x	0	x
Security Erase Prepare	0	0	0
Security Erase Unit	0	0	x
Security Freeze Lock	x	0	0
Security Set Password	x	0	x
Security Unlock	0	0	x
Seek	0	0	0
Sense Condition	0	0	0
Set Features	0	0	0
Set Max ADDRESS	0	0	0
Set Max FREEZE LOCK	0	0	0
Set Max LOCK	0	0	0

Figure 66. Command table for device lock operation (1 of 2)

Command	Device Locked Mode	Device Unlocked Mode	Device Frozen Mode
Set Max SET PASSWORD	0	0	0
Set Max UNLOCK	0	0	0
Set Multiple Mode	0	0	0
Sleep	0	0	0
S.M.A.R.T. Disable Operations	0	0	0
S.M.A.R.T. Enable/Disable automatic off-line	0	0	0
S.M.A.R.T. Enable/Disable Attribute Autosave	0	0	0
S.M.A.R.T. Enable Operations	0	0	0
S.M.A.R.T. Execute Off-line Immediate	0	0	0
S.M.A.R.T. Read Attribute Values	0	0	0
S.M.A.R.T. Read Attribute Thresholds	0	0	0
S.M.A.R.T. Read log sector	0	0	0
S.M.A.R.T. Write log sector	0	0	0
S.M.A.R.T. Return Status	0	0	0
S.M.A.R.T. Save Attribute Values	0	0	0
Standby	0	0	0
Standby Immediate	0	0	0
Write Buffer	0	0	0
Write DMA	x	0	0
Write Long	x	0	0
Write Multiple	x	0	0
Write Sector(s)	x	0	0
Write Verify	x	0	0

Figure 67. Command table for device lock operation (2 of 2)

11.9 Protected Area Function

Protected Area Function is to provide a "protected area" which cannot be accessed via conventional methods. This protected area is used to contain critical system data such as BIOS or system management information. The contents of the entire system main memory may also be dumped into the protected area to resume after a system power off.

The LBA/CYL changed by the following commands affects the Identify Device Information.

Two commands are defined for this function:

Read Native Max ADDRESS ('F8'h)
Set Max ADDRESS ('F9'h)

Four security extension commands are implemented as sub functions of the Set Max ADDRESS:

Set Max SET PASSWORD
Set Max LOCK
Set Max FREEZE LOCK
Set Max UNLOCK

11.9.1 Example for operation (In LBA Mode)

Assumptions :

For easier understanding the following example uses actual values for LBA, size, etc. Since it is an example, these values will differ.

Device characteristics:

Capacity (native)	536,870,912 bytes (536MB)
Max LBA (native)	1,048,575 (0FFFFFFh)
Required size for protected area	8,388,608 bytes
Required blocks for protected area	16,384 (004000h)
Customer usable device size	528,482,304 bytes (528MB)
Customer usable sector count	1,032,192 (0FC000h)
LBA range for protected area	0FC000h to 0FFFFFFh

1. Shipping drives from the drive manufacturer

When the drive is shipped from the manufacturer, the device has been tested to have a capacity of 536 MB, flagging the media defects not visible by the system.

2. Preparing drives at system manufacturer

Special utility software is required to define the size of the protected area and to store the data in it. The sequence is:

Issue Read Native Max ADDRESS command to get the real device max of LBA/CYL. Returned value shows that native device Max LBA is 0FFFFFFh regardless of the current setting.

Make the entire device accessible, including the protected area, by setting the device Max LBA as 0FFFFFFh via Set Max ADDRESS command. The option could be either nonvolatile or volatile.

Test the sectors for protected area (LBA > = 0FC000h) if required.

Write information data such as BIOS code within the protected area.

Change maximum LBA using Set Max ADDRESS command to 0FBFFFh with nonvolatile option.

From this point, the protected area cannot be accessed until next Set Max ADDRESS command is issued. Any BIOS, device driver, or application software accesses the drive as if it is a 528 MB device because the device behaves like a 528 MB device.

3. Conventional usage without system software support:

Since the drive works as a 528 MB device, there is no special care required for normal use of this device.

4. Advanced usage using protected area.

The data in the protected area is accessed by the following steps.

1. Issue Read Native Max ADDRESS command to get the real device max LBA/CYL. Returned value shows that native device Max LBA is 0FFFFFFh regardless of the current setting.
2. Make entire device accessible, including the protected area, by setting device Max LBA as 0FFFFFFh via Set Max ADDRESS command with the volatile option. By using this option, unexpected power removal or reset will prevent the protected area from remaining accessible.
3. Read information data from protected area.
4. Issue hard reset or POR to inhibit any access to the protected area.

11.9.2 Set Max security extension commands

The Set Max SET PASSWORD command allows the host to define the password to be used during the current power on cycle. This password is not related to the password used for the Security Mode Feature set. When the password is set, the device is in the Set Max Unlocked mode.

This command requests a transfer of a single sector of data from the host. The following figure defines the content of this sector of information. The password is retained by the device until the next power cycle. When the device accepts this command, the device is in Set Max Unlocked mode.

Word	Content
0	Reserved
1-16	Password (32 bytes)
17-255	Reserved

Figure 68. Set Max SET PASSWORD data content

The Set Max LOCK command allows the host to disable the Set Max commands (except Set Max UNLOCK and Set Max FREEZE LOCK) until the next power cycle or the issuance and acceptance of the Set Max UNLOCK command. When this command is accepted, the device is in the Set Max Locked mode.

The Set Max UNLOCK command changes the device from the Set Max Locked mode to the Set Max Unlocked mode.

This command requests a transfer of a single sector of data from the host. The figure shown above defines the content of this sector of information. The password supplied in the sector of data transferred is compared with the stored Set Max password. If the password compare fails, then the device returns command aborted and decrements the unlock counter. On the acceptance of the Set Max LOCK command, this counter is set to a value of five and is decremented for each password mismatch when Set

Max UNLOCK is issued and the device is locked. When this counter reaches zero, then the Set Max UNLOCK command returns command aborted until a power cycle.

The Set Max FREEZE LOCK command allows the host to disable the SET MAX commands (including Set Max UNLOCK) until the next power cycle. When this command is accepted the device is in the Set Max Frozen mode.

The password, the Set Max security mode, and the unlock counter do not persist over a power cycle but persist over a hardware or software reset.

NOTE: If this command is immediately preceded by a Read Native MAX ADDRESS command, it shall be interpreted as a Set Max ADDRESS command regardless of Feature register value.

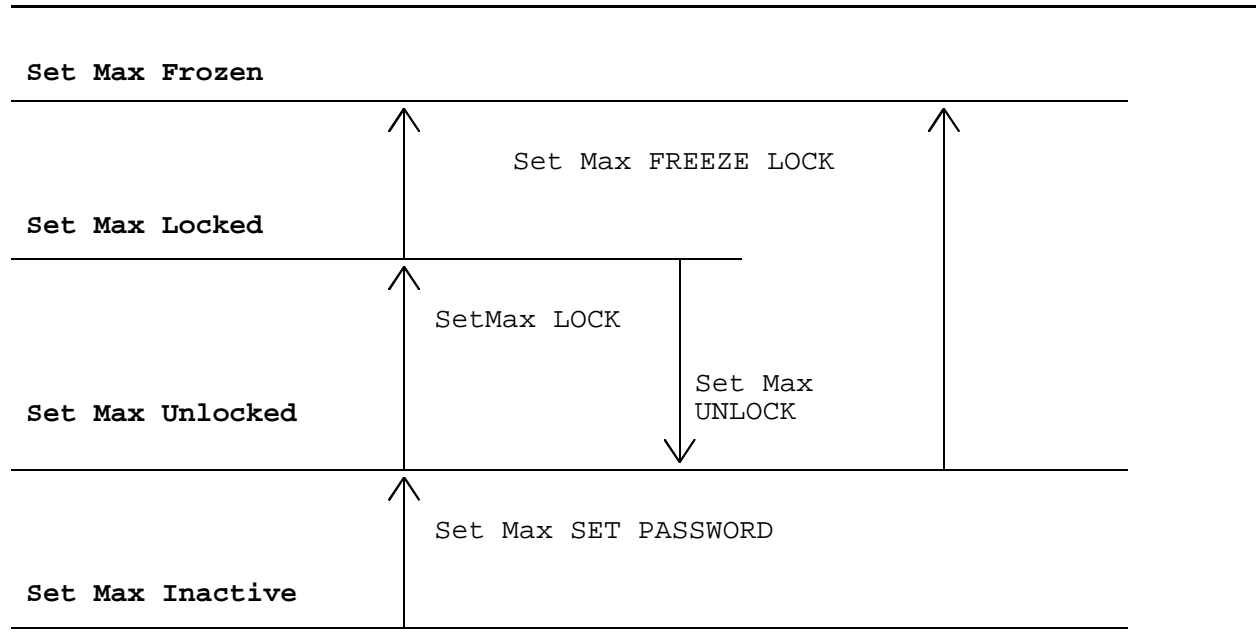

Figure 69. Set Max security mode transition

11.10 Address Offset Feature (vendor specific)

Computer systems perform initial code loading (booting) by reading from a predefined address on a disk drive. To allow an alternate bootable operating system to exist in a reserved area on a disk drive this feature provides a Set Features function to temporarily offset the drive address space. The offset address space wraps around so that the entire disk drive address space remains addressable in offset mode. The Set Max pointer is set to the end of the reserved area to protect the data in the user area when operating in offset mode. This protection can be removed by a Set Max Address command to move the Set Max pointer to the end of the drive. But any commands which access sectors across the original native maximum LBA are rejected with error, even if this protection is removed by a Set Max Address command.

11.10.1 Enable/Disable Address Offset Mode

Subcommand code 09h Enable Address Offset Mode offsets address Cylinder 0, Head 0, Sector 1, LBA 0, to the start of the nonvolatile protected area established using the Set Max Address command. The offset condition is cleared by Subcommand 89h Disable Address Offset Mode, Hardware reset or Power on Reset. If Reverting to Power on Defaults has been enabled by Set Features command, it is cleared by Soft reset as well. Upon entering offset mode the capacity of the drive returned in the Identify Device data is the size of the former protected area. A subsequent Set Max Address command with the address returned by the Read Max Address command allows access to the entire drive. Addresses wrap so the entire drive remains addressable.

If a nonvolatile protected area has not been established before the device receives a Set Features Enable Address Offset Mode command, the command fails with Abort error status.

Disable Address Offset Feature removes the address offset and sets the size of the drive reported by the Identify Device command back to the size specified in the last nonvolatile Set Max Address command.

Before Enable Address Offset Mode

A reserved area has been created using a non-volatile Set Max command.

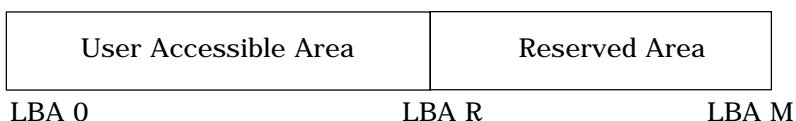

After Enable Address Offset Mode

The former reserved area is now the user accessible area.

The former user accessible area is now the reserved area.



After Set Max Address Command using the Value Returned by Read Max Address

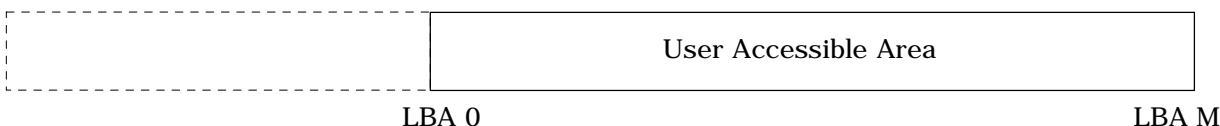

Figure 70. Device address map before and after Set Feature

11.10.2 Identify Device Data

Identify Device data, word 83, bit 7 indicates the device supports the Address Offset Feature. Identify Device data, word 86, bit 7 indicates the device is in Address Offset mode.

11.10.3 Exceptions in Address Offset Mode

Any commands which access sectors across the original native maximum LBA are rejected with error, even if the access protection is removed by a Set Max Address command.

Read Look Ahead operation is not carried out, even if it is enabled by the Set Feature command.

11.11 Seek Overlap

The drive provides accurate seek time measurement method. The seek command is usually used to measure the device seek time by accumulating execution time for a number of seek commands. With typical implementation of the seek command, this measurement must include the device and host command overhead. To eliminate this overhead, the drive overlaps the seek command as described below.

The first seek command completes before the actual seek operation is over. Then the device can receive the next seek command from the host. However, the actual seek operation for the next seek command starts right after completion of the actual seek operation for the first seek command. The execution of two seek commands overlaps excluding the actual seek operation.

With this overlap, total elapsed time for a number of seek commands is the total accumulated time for the actual seek operation plus one pre and post overhead. When the number of seeks is large, this overhead can be ignored.

(1) With overlap

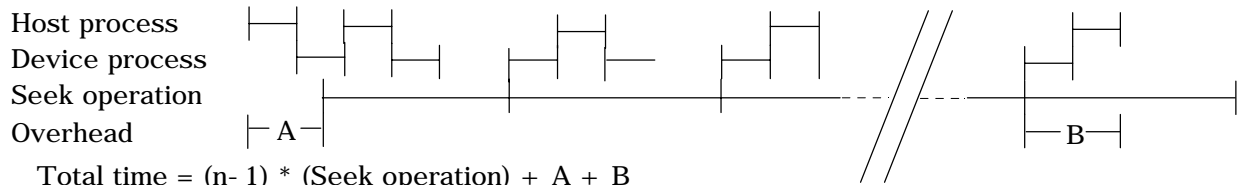

(2) Without overlap

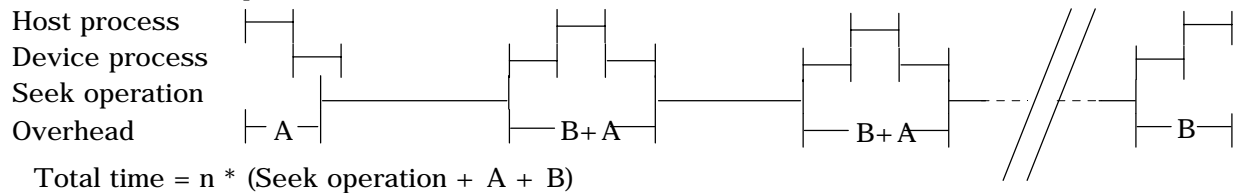

Figure 71. Seek overlap

11.12 Write Cache function

Write cache is a performance enhancement whereby the device reports completion of the write command (Write Sectors and Write Multiple) to the host as soon as the device has received all of the data in its buffer. The device assumes responsibility to write the data subsequently onto the disk.

- Even though writing data after completed acknowledgment of a write command, soft reset, or hard reset does not affect its operation, power off terminates writing operation immediately and unwritten data is lost.
- Flush cache, Soft reset, Standby, Standby Immediate, and Sleep are executed after the completion of writing to disk media on enabling write cache function. The host system can confirm the completion of write cache operation by issuing flush cache command, Soft reset, Standby command, Standby Immediate command, or Sleep command, and confirming the completion of the issued command.

11.13 Delayed Write function (vendor specific)

Delayed Write function is a power saving enhancement whereby the device delays the actual data writing into the media. When the device is in the power saving mode and the Write command (Write Sectors, Write Multiple, or Write DMA) comes from the host, the transferred data is not written into the media immediately, it is only stored into the cache buffer. When the cache buffer becomes full or reaches the predefined size or if any command except the Write command is issued, the operation to write the data from the cache buffer into the media is begun.

Power consumption can be reduced by Delayed Write. When Write commands come with a long interval, the device must exit from the power saving mode and enter into the power saving mode again without Delayed Write function. If Delayed Write is enabled, such power saving mode transition times can be reduced. As a result, the additional energy for power saving mode transition can be saved and the average power consumption of the device can be reduced.

However, the time elapsed from the completion of the Write command to the media write completion will be extended with Delayed Write function. If the power for the device is turned off during this time, the data which has not been written to the media is lost. Therefore, a command listed in the Write Cache Function section is issued before the power off to confirm whole cached data has been written into the media.

For the sake of safety, Delayed Write function is disabled at Power On Default. The Enable Delayed Write command is issued to the device to enable Delayed Write function at every Power On Reset or Hard Reset. The actions of each reset are shown in Figure 57 on page 72.

11.13.1 Enable/Disable Delayed Write command

Command code FAh with Feature register 07h enables Delayed Write function.

Command code FAh with Feature register 87h disables Delayed Write function.

Ensure that, even if Delayed Write function is enabled by this command, Delayed Write does not work when Write Cache function is disabled.

11.14 Reassign Function

The Reassign Function is used with read commands and write commands. The sectors of data for reassignment are prepared as the spare data sector. The one entry can register 256 consecutive sectors maximum.

This reassignment information is registered internally, and the information is available right after completing the reassign function. Also the information is used on the next power on reset or hard reset.

If the number of the spare sector reaches 0 sector, the reassign function will be disabled automatically.

The spare sectors for reassignment are located in a reserved area. As a result of reassignment, the physical location of logically sequenced sectors is dispersed.

11.14.1 Auto Reassign Function

The sectors that show some errors may be reallocated automatically when specific conditions are met. The spare sectors for reallocation are located in a reserved area. The conditions for auto-reallocation are described below.

Nonrecovered write errors

When a write operation can not be completed after the Error Recovery Procedure (ERP) is fully carried out, the sector(s) are reallocated to the spare location. An error is reported to the host system only when the write cache is disabled and the auto reallocation fails.

If the number of available spare sectors reaches 16 sectors, the write cache function will be disabled automatically.

Nonrecovered read errors

When a read operation fails after a defined ERP is fully carried out, a hard error is reported to the host system. This location is registered internally as a candidate for the reallocation. When a registered location is specified as a target of a write operation, a sequence of media verifications is performed automatically. When the result of this verification meets the criteria, this sector is reallocated.

Recovered read errors

When a read operation for a sector fails once and then is recovered at the specific ERP step, this sector of data is reallocated automatically. A media verification sequence may be run prior to the relocation according to the predefined conditions.

This page intentionally left blank.

12.0 Command protocol

The commands are grouped into different classes according to the protocols followed for command execution. The command classes with their associated protocols are defined below.

For all commands, the host must first check to see if BSY = 1, and should proceed no further unless and until BSY = 0. For all commands, the host must also wait for RDY = 1 before proceeding.

A device must maintain either BSY = 1 or DRQ = 1 at all times until the command is completed. The INTRQ signal is used by the device to signal most, but not all, times when the BSY bit is changed from 1 to 0 during command execution.

A command shall only be interrupted with a hardware or software reset. The result of writing to the Command register while BSY = 1 or DRQ = 1 is unpredictable and may result in data corruption. A command should only be interrupted by a reset at times when the host thinks there may be a problem, such as a device that is no longer responding.

Interrupts are cleared when the host reads the Status Register, issues a reset, or writes to the Command Register.

See Section 14.0, "Time-out values" on page 191 for the device time-out values.

12.1 Data In commands

These commands are:

- Identify Device
- Read Buffer
- Read Long
- Read Multiple
- Read Sectors
- S.M.A.R.T. Read Attribute Values
- S.M.A.R.T. Read Attribute Thresholds
- S.M.A.R.T. Read log sector

Execution includes the transfer of one or more 512 byte (> 512 bytes on Read Long) sectors of data from the device to the host.

1. The host writes any required parameters to the Features, Sector Count, Sector Number, Cylinder, and Device/Head Registers.
2. The host writes the command code to the Command Register.
3. For each sector (or block) of data to be transferred:
 - a. The device sets BSY = 1 and prepares for data transfer.
 - b. When a sector (or block) of data is available for transfer to the host, the device sets BSY = 0, sets DRQ = 1, and interrupts the host.
 - c. In response to the interrupt, the host reads the Status Register.
 - d. The device clears the interrupt in response to the Status Register being read.

- e. The host reads one sector (or block) of data via the Data Register.
 - f. The device sets DRQ = 0 after the sector (or block) has been transferred to the host.
4. For the Read Long command:
- a. The device sets BSY = 1 and prepares for data transfer.
 - b. When the sector of data is available for transfer to the host, the device sets BSY = 0 and DRQ = 1 and interrupts the host.
 - c. In response to the interrupt, the host reads the Status Register.
 - d. The device clears the interrupt in response to the Status Register being read.
 - e. The host reads the sector of data including ECC bytes via the Data Register.
 - f. The device sets DRQ = 0 after the sector has been transferred to the host.

The Read Multiple command transfers one block of data for each interrupt. The other commands transfer one sector of data for each interrupt.

Note that the status data for a sector of data is available in the Status Register before the sector is transferred to the host.

If the device detects an invalid parameter, then it will abort the command by setting BSY = 0, ERR = 1, ABT = 1, and interrupting the host.

If an error occurs, the device will set BSY = 0, ERR = 1, and DRQ = 1. The device will then store the error status in the Error Register and interrupt the host. The registers will contain the location of the sector in error. The error location will be reported using CHS mode or LBA mode. The mode is decided by the mode select bit (bit 6) of the Device/Head register upon issuing the command.

If an Uncorrectable Data Error (UNC = 1) occurs, the defective data will be transferred from the media to the sector buffer and will be available for transfer to the host at the host's option. In case of a Read Multiple command, the host should complete transfer of the block which includes the error from the sector buffer and terminate whatever type of error that occurred.

All data transfers to the host through the Data Register are 16 bits. The ECC bytes are an exception having only 8 bits.

12.2 Data Out commands

The following are Data Out commands:

- Device Configuration SET
- Format Track
- Security Disable Password
- Security Erase Unit
- Security Set Password
- Security Unlock
- Set Max SET PASSWORD
- Set Max UNLOCK
- S.M.A.R.T. Write log sector
- Write Buffer
- Write Long
- Write Multiple
- Write Sectors
- Write Verify

Execution includes the transfer of one or more 512 byte (> 512 bytes on Write Long) sectors of data from the host to the device.

1. The host writes any required parameters to the Features, Sector Count, Sector Number, Cylinder, and Device/Head Registers.
2. The host writes the command code to the Command Register.
3. The device sets BSY = 1.
4. For each sector (or block) of data to be transferred:
 - a. The device sets BSY = 0 and DRQ = 1 when it is ready to receive a sector (or block).
 - b. The host writes one sector (or block) of data via the Data Register.
 - c. The device sets BSY = 1 after it has received the sector (or block).
 - d. When the device has finished processing the sector (or block), it sets BSY = 0 and interrupts the host.
 - e. In response to the interrupt, the host reads the Status Register.
 - f. The device clears the interrupt in response to the Status Register being read.
5. For the Write Long command:
 - a. The device sets BSY = 0 and DRQ = 1 when it is ready to receive a sector.
 - b. The host writes one sector of data including ECC bytes via the Data Register.
 - c. The device sets BSY = 1 after it has received the sector.
 - d. After processing the sector of data the device sets BSY = 0 and interrupts the host.
 - e. In response to the interrupt, the host reads the Status Register.
 - f. The device clears the interrupt in response to the Status Register being read.

The Write Multiple command transfers one block of data for each interrupt. The other commands transfer one sector of data for each interrupt.

If the device detects an invalid parameter, then it will abort the command by setting BSY = 0, ERR = 1, ABT = 1, and interrupting the host.

If an uncorrectable error occurs, the device will set BSY = 0 and ERR = 1, store the error status in the Error Register, and interrupt the host. The registers will contain the location of the sector in error. The error location will be reported with CHS mode or LBA mode. The mode is decided by the mode select bit (bit 6) of the Device/Head register on issuing the command.

All data transfers to the host through the Data Register are 16 bits. The ECC bytes are an exception having only 8 bits.

12.3 Nondata commands

The following are Nondata commands:

- Check Power Mode
- Device Configuration FREEZE LOCK
- Device Configuration RESTORE
- Enable/Disable Delayed Write
- Execute Device Diagnostic
- Flush Cache
- Format Unit
- Idle
- Idle Immediate
- Initialize Device Parameters
- Read Native Max ADDRESS
- Read Verify Sectors
- Recalibrate
- Security Erase Prepare
- Security Freeze Lock
- Seek
- Sense Condition
- Set Features
- Set Max ADDRESS
- Set Max LOCK
- Set Max FREEZE LOCK
- Set Multiple Mode
- Sleep
- S.M.A.R.T. Disable Operations
- S.M.A.R.T. Enable/Disable Attribute Auto save
- S.M.A.R.T. Enable/Disable Automatic Off-line
- S.M.A.R.T. Enable Operations
- S.M.A.R.T. Execute Off-line Immediate
- S.M.A.R.T. Return Status
- S.M.A.R.T. Save Attribute Values
- Standby
- Standby Immediate

Execution of these commands involves no data transfer.

1. The host writes any required parameters to the Features, Sector Count, Sector Number, Cylinder, and Device/Head Registers.
2. The host writes the command code to the Command Register.
3. The device sets BSY = 1.
4. When the device has finished processing the command, it sets BSY = 0 and interrupts the host.
5. In response to the interrupt, the host reads the Status Register.
6. The device clears the interrupt in response to the Status Register being read.

12.4 DMA Data Transfer commands

These commands are:

- Read DMA
- Write DMA

Data transfers using DMA commands differ in two ways from PIO transfers:

- Data transfers are performed using the Slave DMA channel
- No intermediate sector interrupts are issued on multisector commands

Initiation of the DMA transfer commands is identical to the Read Sector or Write Sector commands with one exception: the host initializes the Slave DMA channel prior to issuing the command.

The interrupt handler for DMA transfers differs in two ways:

- No intermediate sector interrupts are issued on multisector commands.
- The host resets the DMA channel prior to reading status from the device.

The DMA protocol allows high performance multitasking operating systems to eliminate processor overhead associated with PIO transfers.

1. The host initializes the Slave DMA channel.
2. The host writes any required parameters to the Features, Sector Count, Sector Number, Cylinder, and Device/Head registers.
3. The host writes command code to the Command Register.
4. The device sets DMARQ when it is ready to transfer any part of the data.
5. The host transfers the data using the DMA transfer protocol currently in effect.
6. When all of the data has been transferred, the device generates an interrupt to the host.
7. The host resets the Slave DMA channel.
8. The host reads the Status Register and, optionally, the Error Register.

Refer to section 7.0, "Electrical interface specifications" on page 41 for further details.

13.0 Command descriptions

The table below shows the commands that are supported by the device. Figure 74 on page 105 shows the subcommands that are supported by each command or feature.

Protocol	Command	Code (Hex)	Binary Code Bit							
			7	6	5	4	3	2	1	0
3	Check Power Mode	E5	1	1	1	0	0	1	0	1
3	Check Power Mode*	98	1	0	0	1	1	0	0	0
3	Device Configuration RESTORE	B1	1	0	1	0	0	0	0	1
3	Device Configuration FREEZE LOCK	B1	1	0	1	0	0	0	0	1
1	Device Configuration IDENTIFY	B1	1	0	1	0	0	0	0	1
2	Device Configuration SET	B1	1	0	1	0	0	0	0	1
3	Enable/Disable Delayed Write	FA	1	1	1	1	1	0	1	0
3	Execute Device Diagnostic	90	1	0	0	1	0	0	0	0
3	Flush Cache	E7	1	1	1	0	0	1	1	1
2	Format Track	50	0	1	0	1	0	0	0	0
3+	Format Unit	F7	1	1	1	1	0	1	1	1
1	Identify Device	EC	1	1	1	0	1	1	0	0
3	Idle	E3	1	1	1	0	0	0	1	1
3	Idle*	97	1	0	0	1	0	1	1	1
3	Idle Immediate	E1	1	1	1	0	0	0	0	1
3	Idle Immediate*	95	1	0	0	1	0	1	0	1
3	Initialize Device Parameters	91	1	0	0	1	0	0	0	1
1	Read Buffer	E4	1	1	1	0	0	1	0	0
4	Read DMA	C8	1	1	0	0	1	0	0	0
4	Read DMA	C9	1	1	0	0	1	0	0	1
1	Read Long	22	0	0	1	0	0	0	1	0
1	Read Long	23	0	0	1	0	0	0	1	1
1	Read Multiple	C4	1	1	0	0	0	1	0	0
3	Read Native Max ADDRESS	F8	1	1	1	1	1	0	0	0
1	Read Sectors	20	0	0	1	0	0	0	0	0
1	Read Sectors	21	0	0	1	0	0	0	0	1
3	Read Verify Sectors	40	0	1	0	0	0	0	0	0
3	Read Verify Sectors	41	0	1	0	0	0	0	0	1
3	Recalibrate	1x	0	0	0	1	-	-	-	-
2	Security Disable Password	F6	1	1	1	1	1	0	1	0
3	Security Erase Prepare	F3	1	1	1	1	0	0	1	1
2	Security Erase Unit	F4	1	1	1	1	0	1	0	0
3	Security Freeze Lock	F5	1	1	1	1	0	1	0	1
2	Security Set Password	F1	1	1	1	1	0	0	0	1
2	Security Unlock	F2	1	1	1	1	0	0	1	0
3	Seek	7x	0	1	1	1	-	-	-	-
3	Sense Condition	F0	1	1	1	1	0	0	0	0
3	Set Features	EF	1	1	1	0	1	1	1	1
3	Set Max ADDRESS	F9	1	1	1	1	1	0	0	1
3	Set Max FREEZE LOCK	F9	1	1	1	1	1	0	0	1
3	Set Max LOCK	F9	1	1	1	1	1	0	0	1

Figure 72. Command set (1 of 2)

Protocol	Command	Code (Hex)	Binary Code Bit							
			7	6	5	4	3	2	1	0
2	Set Max SET PASSWORD	F9	1	1	1	1	1	0	0	1
2	Set Max UNLOCK	F9	1	1	1	1	1	0	0	1
3	Set Multiple Mode	C6	1	1	0	0	0	1	1	0
3	Sleep	E6	1	1	1	0	0	1	1	0
3	Sleep*	99	1	0	0	1	1	0	0	1
3	S.M.A.R.T. Disable Operations	B0	1	0	1	1	0	0	0	0
3	S.M.A.R.T. Enable/Disable Attribute Auto save	B0	1	0	1	1	0	0	0	0
3	S.M.A.R.T. Enable/Disable Automatic Off-line	B0	1	0	1	1	0	0	0	0
3	S.M.A.R.T. Enable Operations	B0	1	0	1	1	0	0	0	0
3	S.M.A.R.T. Execute Off-line Immediate	B0	1	0	1	1	0	0	0	0
1	S.M.A.R.T. Read Attribute Values	B0	1	0	1	1	0	0	0	0
1	S.M.A.R.T. Read Attribute Thresholds	B0	1	0	1	1	0	0	0	0
1	S.M.A.R.T. Read Log Sector	B0	1	0	1	1	0	0	0	0
3	S.M.A.R.T. Return Status	B0	1	0	1	1	0	0	0	0
3	S.M.A.R.T. Save Attribute Values	B0	1	0	1	1	0	0	0	0
2	S.M.A.R.T. Write Log Sector	B0	1	0	1	1	0	0	0	0
3	Standby	E2	1	1	1	0	0	0	1	0
3	Standby*	96	1	0	0	1	0	1	1	0
3	Standby Immediate	E0	1	1	1	0	0	0	0	0
3	Standby Immediate*	94	1	0	0	1	0	1	0	0
2	Write Buffer	E8	1	1	1	0	1	0	0	0
4	Write DMA	CA	1	1	0	0	1	0	1	0
4	Write DMA	CB	1	1	0	0	1	0	1	1
2	Write Long	32	0	0	1	1	0	0	1	0
2	Write Long	33	0	0	1	1	0	0	1	1
2	Write Multiple	C5	1	1	0	0	0	1	0	1
2	Write Sectors	30	0	0	1	1	0	0	0	0
2	Write Sectors	31	0	0	1	1	0	0	0	1
2	Write Verify	3C	0	0	1	1	1	1	0	0

Protocol: 1 : PIO data IN command
2 : PIO data OUT command
3 : Non data command
4 : DMA command

Commands marked * are alternate command codes for previously defined commands.

Figure 73. Command set (2 of 2)

Command (Subcommand)	Command Code (Hex)	Feature Register (Hex)
(Delayed Write Function) Enable Delayed Write function Disable Delayed Write function	FA FA	07 87
(S.M.A.R.T Function) S.M.A.R.T. Read Attribute Values S.M.A.R.T. Read Attribute Thresholds S.M.A.R.T. Enable/Disable Attribute Autosave S.M.A.R.T. Save Attribute Values S.M.A.R.T. Execute Off-line Immediate S.M.A.R.T. Read Log Sector S.M.A.R.T. Write Log Sector S.M.A.R.T. Enable Operations S.M.A.R.T. Disable Operations S.M.A.R.T. Return Status S.M.A.R.T. Enable/Disable Automatic Off-line	B0 B0 B0 B0 B0 B0 B0 B0 B0 B0 B0 B0	D0 D1 D2 D3 D4 D5 D6 D8 D9 DA DB
(Set Features) Enable Write Cache Set Transfer mode Enable Advanced Power Management feature Enable Address Offset mode 40 bytes of ECC apply on Read/Write Long Disable read look-ahead feature Disable reverting to power on defaults Disable write cache Disable Advanced Power Management feature Disable Address Offset mode Enable read look-ahead feature 4 bytes of ECC apply on Read/Write Long Enable reverting to power on defaults	EF EF EF EF EF EF EF EF EF EF EF EF EF	02 03 05 09 44 55 66 82 85 89 AA BB CC
(Set Max Security Extension) Set Max SET PASSWORD Set Max LOCK Set Max UNLOCK Set Max FREEZE LOCK	F9 F9 F9 F9	01 02 03 04
(Device Configuration Overlay) Device Configuration RESTORE Device Configuration FREEZE LOCK Device Configuration IDENTIFY Device Configuration SET	B1 B1 B1 B1	C0 C1 C2 C3

Figure 74. Command Set (Subcommand)

The following symbols are used in the command descriptions:

Output Registers

- 0** This indicates that the bit must be set to 0.
- 1** This indicates that the bit must be set to 1.
- D** The device number bit. Indicates that the device number bit of the Device/Head Register should be specified. Zero selects the master device and one selects the slave device.
- H** Head number. This indicates that the head number part of the Device/Head Register is an output parameter and should be specified.
- L** LBA mode. This indicates the addressing mode. Zero specifies CHS mode and one specifies LBA addressing mode.
- R** Retry. Original meaning is already obsolete, there is no difference between 0 and 1. (Using 0 is recommended for future compatibility.)
- B** Option Bit. This indicates that the Option Bit of the Sector Count Register be specified. (This bit is used by Set Max ADDRESS command.)
- V** Valid. This indicates that the bit is part of an output parameter and should be specified.
- x** This indicates that the hex character is not used.
- This indicates that the bit is not used.

Input Registers

- 0** This indicates that the bit is always set to 0.
- 1** This indicates that the bit is always set to 1.
- H** Head number. This indicates that the head number part of the Device/Head Register is an input parameter and will be set by the device.
- V** Valid. This indicates that the bit is part of an input parameter and will be set by the device to 0 or 1.
- N** Not recommended condition for start up. Indicates that the condition of the device is not recommended for start up.
- This indicates that the bit is not part of an input parameter.

The command descriptions show the contents of the Status and Error Registers after the device has completed processing the command and has interrupted the host.

13.1 Check Power Mode (E5h/98h)

Command Block Output Registers								Command Block Input Registers									
Register	7	6	5	4	3	2	1	0	Register	7	6	5	4	3	2	1	0
Data	-	-	-	-	-	-	-	-	Data	-	-	-	-	-	-	-	-
Feature	-	-	-	-	-	-	-	-	Error	see below							
Sector Count	-	-	-	-	-	-	-	-	Sector Count	V	V	V	V	V	V	V	V
Sector Number	-	-	-	-	-	-	-	-	Sector Number	-	-	-	-	-	-	-	-
Cylinder Low	-	-	-	-	-	-	-	-	Cylinder Low	-	-	-	-	-	-	-	-
Cylinder High	-	-	-	-	-	-	-	-	Cylinder High	-	-	-	-	-	-	-	-
Device/Head	1	-	1	D	-	-	-	-	Device/Head	-	-	-	-	-	-	-	-
Command	1	1	1	0	0	1	0	1	Status	see below							

Error Register							
7	6	5	4	3	2	1	0
CRC	UNC	0	IDN	0	ABT	T0N	AMN
0	0	0	0	0	V	0	0

Status Register							
7	6	5	4	3	2	1	0
BSY	RDY	DF	DSC	DRQ	COR	IDX	ERR
0	V	0	-	-	0	-	V

Figure 75. Check Power Mode command (E5h/98h)

The Check Power Mode command will report whether the device is spun up and the media is available for immediate access.

Input parameters from the device

Sector Count This indicates the power mode code. The command returns FFh in the Sector Count Register if the spindle motor is at speed and the device is not in Standby or Sleep mode. Otherwise, the Sector Count Register is set to 0.

13.2 Device Configuration Overlay (B1h)

Command Block Output Registers								Command Block Input Registers									
Register	7	6	5	4	3	2	1	0	Register	7	6	5	4	3	2	1	0
Data	-	-	-	-	-	-	-	-	Data	-	-	-	-	-	-	-	-
Feature	1	0	1	0	V	V	V	V	Error	see below							
Sector Count	-	-	-	-	-	-	-	-	Sector Count	V	V	V	V	V	V	V	V
Sector Number	-	-	-	-	-	-	-	-	Sector Number	-	-	-	-	-	-	-	-
Cylinder Low	-	-	-	-	-	-	-	-	Cylinder Low	V	V	V	V	V	V	V	V
Cylinder High	-	-	-	-	-	-	-	-	Cylinder High	V	V	V	V	V	V	V	V
Device/Head	-	-	-	D	-	-	-	-	Device/Head	-	-	-	-	-	-	-	-
Command	1	0	1	1	0	0	0	1	Status	see below							

Error Register							
7	6	5	4	3	2	1	0
CRC	UNC	0	IDN	0	ABT	T0N	AMN
0	0	0	0	0	V	0	0

Status Register							
7	6	5	4	3	2	1	0
BSY	RDY	DF	DSC	DRQ	COR	IDX	ERR
V	V	V	-	V	-	-	V

Figure 76. Check Power Mode Command (E5h/98h)

Individual Device Configuration Overlay feature set commands are identified by the value placed in the Features register. The table below shows these Features register values.

Value	Command
C0h	DEVICE CONFIGURATION RESTORE
C1h	DEVICE CONFIGURATION FREEZE LOCK
C2h	DEVICE CONFIGURATION IDENTIFY
C3h	DEVICE CONFIGURATION SET
other	Reserved

Figure 77. Device Configuration Overlay Features register values

13.2.1 DEVICE CONFIGURATION RESTORE (subcommand C0h)

The DEVICE CONFIGURATION RESTORE command disables any setting previously made by a DEVICE CONFIGURATION SET command and returns the content of the IDENTIFY DEVICE or IDENTIFY PACKET DEVICE command response to the original settings as indicated by the data returned from the execution of a DEVICE CONFIGURATION IDENTIFY command.

13.2.2 DEVICE CONFIGURATION FREEZE LOCK (subcommand C1h)

The DEVICE CONFIGURATION FREEZE LOCK command prevents accidental modification of the Device Configuration Overlay settings. After successful execution of a DEVICE CONFIGURATION FREEZE LOCK command, all DEVICE CONFIGURATION SET, DEVICE CONFIGURATION FREEZE LOCK, DEVICE CONFIGURATION IDENTIFY, and DEVICE CONFIGURATION RESTORE commands are aborted by the device. The DEVICE CONFIGURATION FREEZE LOCK condition shall be cleared by a power-down. The DEVICE CONFIGURATION FREEZE LOCK condition shall not be cleared by hardware or software reset.

13.2.3 DEVICE CONFIGURATION IDENTIFY (subcommand C2h)

The DEVICE CONFIGURATION IDENTIFY command returns a 512 byte data structure via PIO data-in transfer. The content of this data structure indicates the selectable commands, modes, and feature sets that the device is capable of supporting. If a DEVICE CONFIGURATION SET command has been issued reducing the capabilities, the response to an IDENTIFY DEVICE or IDENTIFY PACKET DEVICE command will reflect the reduced set of capabilities, while the DEVICE CONFIGURATION IDENTIFY command will reflect the entire set of selectable capabilities.

The format of the Device Configuration Overlay data structure is shown on the next page.

13.2.4 DEVICE CONFIGURATION SET (subcommand C3h)

The DEVICE CONFIGURATION SET command allows a device manufacturer or a personal computer system manufacturer to reduce the set of optional commands, modes, or feature sets supported by a device as indicated by a DEVICE CONFIGURATION IDENTIFY command. The DEVICE CONFIGURATION SET command transfers an overlay that modifies some of the bits set in words 63, 82, 83, 84, and 88 of the IDENTIFY DEVICE command response. When the bits in these words are cleared, the device no longer support the indicated command, mode, or feature set. If a bit is set in the overlay transmitted by the device that is not set in the overlay received from a DEVICE CONFIGURATION IDENTIFY command, no action is taken for that bit.

The format of the overlay transmitted by the device is described in the table on the next page. The restrictions on changing these bits is described in the text following that table. If any of the bit modification restrictions described are violated or any setting is changed with DEVICE CONFIGURATION SET command, the device shall return command aborted. At that case, error reason code is returned to sector count register, invalid word location is returned to cylinder high register, and invalid bit location is returned to cylinder low register. The Definition of error information is shown on the next page.

ERROR INFORMATION EXAMPLE 1:

After establishing a protected area with SET MAX address, if a user attempts to change maximum LBA address (DC SET or DC RESTORE), the device aborts that command and returns error reason code as below.

```
Cylinder high   :   03h = word 3 is invalid
Cylinder low    :   00h this register is not assigned in this case
Sector count    :   06h = Protected area is now established
```

ERROR INFORMATION EXAMPLE 2:

When the device is enabled and the Security feature is set, if the user attempts to disable that feature, the device aborts that command and returns an error reason code as below.

```
Cylinder high   : 07h = word 7 is invalid
Cylinder low   : 03h = bit 3 is invalid
Sector count   : 04h = now Security feature set is enabled
```

Word	Content
0	0001h Data Structure revision
1	Multiword DMA modes supported 15-3 Reserved 2 1 = Multiword DMA mode 2 and below are supported 1 1 = Multiword DMA mode 1 and below are supported 0 1 = Multiword DMA mode 0 is supported
2	Ultra DMA modes supported 15-6 Reserved 5 1 = Ultra DMA mode 5 and below are supported 4 1 = Ultra DMA mode 4 and below are supported 3 1 = Ultra DMA mode 3 and below are supported 2 1 = Ultra DMA mode 2 and below are supported 1 1 = Ultra DMA mode 1 and below are supported 0 1 = Ultra DMA mode 0 is supported
3-6	Maximum LBA address
7	Command set/feature set supported 15-8 Reserved 7 1 = Host Protected Area feature set supported 6-4 Reserved 3 1 = Security feature set supported 2 1 = SMART error log supported 1 1 = SMART self-test supported 0 1 = SMART feature set supported
8-254	Reserved
255	Integrity word <see note below> 15-8 Checksum 7-0 Signature (A5h)

Figure 78. Device Configuration Overlay Data structure

Note: Bits 7–0 of this word contain the value A5h. Bits 15–8 of this word contain the data structure checksum. The data structure checksum is the two's complement of the sum of all byte in words 0 through 254 and the byte consisting of bits 7–0 of word 255. Each byte is added with unsigned arithmetic, and overflow is ignored. The sum of all bytes is zero when the checksum is correct.

Cylinder high	invalid word location
Cylinder low	invalid bit location
Sector count	error reason code & description
	01h DCO feature is frozen
	02h Device is now Security Locked mode
	03h Device's feature is already modified with DCO
	04h User attempt to disable any feature enabled
	05h Device is now SET MAX Locked or Frozen mode
	06h Protected area is now established
	07h DCO is not supported
	08h Subcommand code is invalid
	FFh other reason

Figure 79. DCO error information definition

13.3 Enable/Disable Delayed Write (FAh: vendor specific)

Command Block Output Registers								Command Block Input Registers									
Register	7	6	5	4	3	2	1	0	Register	7	6	5	4	3	2	1	0
Data	-	-	-	-	-	-	-	-	Data	-	-	-	-	-	-	-	-
Feature	V	V	V	V	V	V	V	V	Error	see below							
Sector Count	-	-	-	-	-	-	-	-	Sector Count	-	-	-	-	-	-	-	-
Sector Number	-	-	-	-	-	-	-	-	Sector Number	-	-	-	-	-	-	-	-
Cylinder Low	-	-	-	-	-	-	-	-	Cylinder Low	-	-	-	-	-	-	-	-
Cylinder High	-	-	-	-	-	-	-	-	Cylinder High	-	-	-	-	-	-	-	-
Device/Head	1	-	1	D	-	-	-	-	Device/Head	-	-	-	-	-	-	-	-
Command	1	1	1	1	1	0	1	0	Status	see below							

Error Register							
7	6	5	4	3	2	1	0
CRC	UNC	0	IDN	0	ABT	T0N	AMN
0	0	0	0	0	V	0	0

Status Register							
7	6	5	4	3	2	1	0
BSY	RDY	DF	DSC	DRQ	COR	IDX	ERR
0	0	0	-	-	0	-	V

Figure 80. Enable/Disable Delayed Write command (FAh)

The Enable/Disable Delayed Write command sets if the Delayed Write function is enabled or disabled. Delayed Write function is enabled or disabled according to the feature register's value.

Even if the Delayed Write function is enabled by this command, Delayed Write does not work when the Write Cache function is disabled.

For details for this function refer to section 11.13, "Delayed Write Function (Vendor Specific)" on page 94.

Output parameters to the device

Feature This is the destination code for this command.

07H is the Enable Delayed Write function

87H is the Disable Delayed Write function

13.4 Execute Device Diagnostic (90h)

Command Block Output Registers								Command Block Input Registers									
Register	7	6	5	4	3	2	1	0	Register	7	6	5	4	3	2	1	0
Data	-	-	-	-	-	-	-	-	Data	-	-	-	-	-	-	-	-
Feature	-	-	-	-	-	-	-	-	Error	see below							
Sector Count	-	-	-	-	-	-	-	-	Sector Count	-	-	-	-	-	-	-	-
Sector Number	-	-	-	-	-	-	-	-	Sector Number	-	-	-	-	-	-	-	-
Cylinder Low	-	-	-	-	-	-	-	-	Cylinder Low	-	-	-	-	-	-	-	-
Cylinder High	-	-	-	-	-	-	-	-	Cylinder High	-	-	-	-	-	-	-	-
Device/Head	1	-	1	-	-	-	-	-	Device/Head	-	-	-	-	-	-	-	-
Command	1	0	0	1	0	0	0	0	Status	see below							

Error Register							
7	6	5	4	3	2	1	0
CRC	UNC	0	IDN	0	ABT	TON	AMN
0	V	V	V	V	V	V	V

Status Register							
7	6	5	4	3	2	1	0
BSY	RDY	DF	DSC	DRQ	COR	IDX	ERR
0	0	0	-	-	0	-	0

Figure 81. Execute Device Diagnostic command (90h)

The Execute Device Diagnostic command performs the internal diagnostic tests implemented by the device. The results of the test are stored in the Error Register.

The normal Error Register bit definitions do not apply to this command. Instead, the register contains a diagnostic code. See Figure 59 on page 73 for the definition.

13.5 Flush Cache (E7h)

Command Block Output Registers								Command Block Input Registers									
Register	7	6	5	4	3	2	1	0	Register	7	6	5	4	3	2	1	0
Data	-	-	-	-	-	-	-	-	Data	-	-	-	-	-	-	-	-
Feature	-	-	-	-	-	-	-	-	Error	see below							
Sector Count	-	-	-	-	-	-	-	-	Sector Count	-	-	-	-	-	-	-	-
Sector Number	-	-	-	-	-	-	-	-	Sector Number	-	-	-	-	-	-	-	-
Cylinder Low	-	-	-	-	-	-	-	-	Cylinder Low	-	-	-	-	-	-	-	-
Cylinder High	-	-	-	-	-	-	-	-	Cylinder High	-	-	-	-	-	-	-	-
Device/Head	1	-	1	D	-	-	-	-	Device/Head	-	-	-	-	-	-	-	-
Command	1	1	1	0	0	1	1	1	Status	see below							

Error Register							
7	6	5	4	3	2	1	0
CRC	UNC	0	IDN	0	ABT	TON	AMN
0	0	0	0	0	V	0	0

Status Register							
7	6	5	4	3	2	1	0
BSY	RDY	DF	DSC	DRQ	COR	IDX	ERR
0	V	0	V	-	0	-	V

Figure 82. Flush Cache command (E7h)

This command causes the device to complete writing data from its cache.

The device returns a status of RDY = 1 and DSC = 1 (50h) after following sequence:

- Data in the write cache buffer is written to the disk media.
- Return a successful completion

13.6 Format Track (50h: vendor specific)

Command Block Output Registers								Command Block Input Registers									
Register	7	6	5	4	3	2	1	0	Register	7	6	5	4	3	2	1	0
Data	-	-	-	-	-	-	-	-	Data	-	-	-	-	-	-	-	-
Feature	-	-	-	-	-	-	-	-	Error	see below							
Sector Count	-	-	-	-	-	-	-	-	Sector Count	-	-	-	-	-	-	-	-
Sector Number	V	V	V	V	V	V	V	V	Sector Number	V	V	V	V	V	V	V	V
Cylinder Low	V	V	V	V	V	V	V	V	Cylinder Low	V	V	V	V	V	V	V	V
Cylinder High	V	V	V	V	V	V	V	V	Cylinder High	V	V	V	V	V	V	V	V
Device/Head	1	L	1	D	H	H	H	H	Device/Head	-	-	-	-	H	H	H	H
Command	0	1	0	1	0	0	0	0	Status	see below							

Error Register							
7	6	5	4	3	2	1	0
CRC	UNC	0	IDN	0	ABT	TON	AMN
0	0	0	V	0	V	0	0

Status Register							
7	6	5	4	3	2	1	0
BSY	RDY	DF	DSC	DRQ	COR	IDX	ERR
0	V	V	V	-	0	-	V

Figure 83. Format Track command (50h)

The Format Track command formats a single logical track on the device. Each good sector of data on the track will be initialized to zero with the write operation. At this time, the read operation does not verify the correct initialization of the data sector. Any data previously stored on the track will be lost.

Output parameters to the device

Sector Number In LBA mode this register specifies that LBA address bits 0–7 are to be formatted. (L = 1)

Cylinder High/Low This indicates the cylinder number of the track to be formatted. (L = 0)
In LBA mode this register specifies that LBA address bits 8–15 (Low) and bits 16–23 (High) are to be formatted. (L = 1)

H This indicates the head number of the track to be formatted. (L = 0)
In LBA mode this register specifies that LBA address bits 24–27 are to be formatted. (L = 1)

Input parameters from the device

Sector Number In LBA mode this register specifies the current LBA address bits as 0–7 (L = 1).

Cylinder High/Low In LBA mode this register specifies the current LBA address bits as 8–15 (Low) and bits 16–23 (High).

H In LBA mode this register specifies the current LBA address bits as 24–27 (L = 1).
In LBA mode this command formats a single logical track including the specified LBA.

13.7 Format Unit (F7h: vendor specific)

Command Block Output Registers								Command Block Input Registers									
Register	7	6	5	4	3	2	1	0	Register	7	6	5	4	3	2	1	0
Data	-	-	-	-	-	-	-	-	Data	-	-	-	-	-	-	-	-
Feature	V	V	V	V	V	V	V	V	Error	see below							
Sector Count	-	-	-	-	-	-	-	-	Sector Count	-	-	-	-	-	-	-	-
Sector Number	-	-	-	-	-	-	-	-	Sector Number	-	-	-	-	-	-	-	-
Cylinder Low	-	-	-	-	-	-	-	-	Cylinder Low	-	-	-	-	-	-	-	-
Cylinder High	-	-	-	-	-	-	-	-	Cylinder High	-	-	-	-	-	-	-	-
Device/Head	1	-	1	D	-	-	-	-	Device/Head	-	-	-	-	-	-	-	-
Command	1	1	1	1	0	1	1	1	Status	see below							

Error Register							
7	6	5	4	3	2	1	0
CRC	UNC	0	IDN	0	ABT	TON	AMN
0	0	0	V	0	V	0	0

Status Register							
7	6	5	4	3	2	1	0
BSY	RDY	DF	DSC	DRQ	COR	IDX	ERR
0	V	0	V	-	0	-	V

Figure 84. Format Unit command (F7h)

The Format Unit command initializes all user data sectors after merging the reassigned sector location into the defect information of the device and clearing the reassign information. Both new reassign information and new defect information are available right after the completion of this command. They are also used on the next power on reset or hard reset. This command erases both previous information data from the device.

Note that the Format Unit command initializes from LBA 0 to Native MAX LBA. Host MAX LBA is set by Initialize Drive Parameter or Set MAX ADDRESS command is ignored. The protected area by Set MAX ADDRESS command is also initialized.

The Security Erase Prepare command should be completed immediately prior to the Format Unit command. If the device receives a Format Unit command without a prior Security Erase Prepare command, the device aborts the Format Unit command.

If the Feature register is NOT 11h, the device returns an Abort error to the host.

This command does not request a data transfer.

Output parameters to the device

Feature

This indicates the Destination code for this command.

11H The merge reassigned location into the defect information.

The execution time of this command is shown below.

Model number	Execution time
IC25T060ATCX05	60 min
IC25N040ATCX04	44 min
IC25N030ATCX04	34 min
IC25N020ATCX04	22 min
IC25N010ATCX04	12 min

13.8 Identify Device (ECh)

Command Block Output Registers								Command Block Input Registers									
Register	7	6	5	4	3	2	1	0	Register	7	6	5	4	3	2	1	0
Data	-	-	-	-	-	-	-	-	Data	-	-	-	-	-	-	-	-
Feature	-	-	-	-	-	-	-	-	Error	see below							
Sector Count	-	-	-	-	-	-	-	-	Sector Count	-	-	-	-	-	-	-	-
Sector Number	-	-	-	-	-	-	-	-	Sector Number	-	-	-	-	-	-	-	-
Cylinder Low	-	-	-	-	-	-	-	-	Cylinder Low	-	-	-	-	-	-	-	-
Cylinder High	-	-	-	-	-	-	-	-	Cylinder High	-	-	-	-	-	-	-	-
Device/Head	1	-	1	D	-	-	-	-	Device/Head	-	-	-	-	-	-	-	-
Command	1	1	1	0	1	1	0	0	Status	see below							

Error Register							
7	6	5	4	3	2	1	0
CRC	UNC	0	IDN	0	ABT	TON	AMN
0	0	0	0	0	V	0	0

Status Register							
7	6	5	4	3	2	1	0
BSY	RDY	DF	DSC	DRQ	COR	IDX	ERR
0	V	0	-	-	0	-	V

Figure 85. Identify Device command (ECh)

The Identify Device command requests the device to transfer configuration information to the host. The device will transfer a sector to the host containing the information in Figure 86. beginning on page 119.

Word	Content	Description	
00	045AH	drive classification	
		15(=0)	1=ATAPI device, 0=ATA device
		* 14(=0)	1=format speed tolerance gap required
		* 13(=0)	1=track offset option available
		* 12(=0)	1=data strobe offset option available
		* 11(=0)	1=rotational speed tolerance > 0.5%
		* 10(=1)	1=disk transfer rate > 10 Mbps
		* 9(=0)	1=disk transfer rate > 5 Mbps but <= 10 Mbps
		* 8(=0)	1=disk transfer rate <= 5 Mbps
		7(=0)	1=removable cartridge drive
		6(=1)	1=fixed drive
		* 5(=0)	1=spindle motor control option implemented
		* 4(=1)	1=head switch time > 15 μ s
		* 3(=1)	1=not MFM encoded
		* 2(=0)	1=identify data incomplete
		* 1(=1)	1=hard sectored
	0(=0)	Reserved	
01	(Note 1)	Number of cylinders in default translate mode	
02	C837H	SET FEATURES subcommand is not required to spin-up and IDENTIFY DEVICE response is complete	
03	(Note 1)	Number of heads in default translate mode	
04	0 *	Reserved	
05	0 *	Reserved	
06	003FH	Number of sectors per track in default translate mode	
07	0	Reserved	
08	0	Reserved	
09	0000H *	Reserved	
10-19	XXXX	Serial number in ASCII (0 = not specified)	
20	0003H *	Controller type: 0003: dual ported, multiple sector buffer with look-ahead read	
21	(Note 1) *	Buffer size in 512-byte increments	
22	00XXH *	Number of ECC bytes as currently selected via the set feature command	
23-26	XXXX	Micro code version in ASCII	
27-46	(Note 1)	Model number in ASCII	
47	8010H	Maximum number of sectors that can be transferred per interrupt on Read and Write Multiple commands 15-8: (=80h) 7-0: Maximum number of sectors that can be transferred per interrupt.	

* in Content field indicates the use of those parameters that are vendor specific.

Note 1. See Figure 93.

Figure 86. Identify device information. (Part 1 of 7)

Word	Content	Description
48	0000H *	Capable of double word I/O, '0000'= cannot perform
49	0F00H *	Capabilities, bit assignments: 15-14(=0) Reserved 13(=0) Standby timer value are vendor specific 12(=0) Reserved 11(=1) IORDY Supported 10(=1) IORDY can be disabled 9(=1) Reserved 8(=0) Reserved 7-0(=0) Reserved
50	4000H	Capabilities 15(=0) 0=the contents of word 50 are valid 14(=1) 1=the contents of word 50 are valid 13- 1(=0) Reserved 0(=0) 1=the device has a minimum Standby timer value that is device specific
51	0200H *	PIO data transfer cycle timing mode
52	0200H *	DMA data transfer cycle timing mode Refer Word 62 and 63
53	0007H	Validity flag of the word 15- 3(=0) Reserved 2(=1) 1=Word 88 is Valid 1(=1) 1=Word 64-70 are Valid 0(=1) 1=Word 54-58 are Valid
54	XXXXH	Number of current cylinders
55	XXXXH	Number of current heads
56	XXXXH	Number of current sectors per track
57-58	XXXXH	Current capacity in sectors Word 57 specifies the low word of the capacity
59	0XXXXH	Current Multiple setting. Bit assignments: 15- 9(=0) Reserved 8 1= Multiple Sector Setting is Valid 7- 0 xxh = Current setting for number of sectors
60-61	(Note 1)	Total Number of User Addressable Sectors Word 60 specifies the low word of the number
62	0000H *	Reserved
63	XX07H	Multiword DMA Transfer Capability 15-11(=0) Reserved 10 1=Multiword DMA mode 2 is selected 9 1=Multiword DMA mode 1 is selected 8 1=Multiword DMA mode 0 is selected 7- 3(=0) Reserved 2 1=Multiword DMA mode 2 is supported 1 1=Multiword DMA mode 1 is supported 0 1=Multiword DMA mode 0 is supported

* in Content field indicates the use of those parameters that are vendor specific.

Note 1. See Figure 93.

Figure 87. Identify device information. (Part 2 of 7)

Word	Content	Description
64	0003H	Flow Control PIO Transfer Modes Supported 15- 8(=0) Reserved 7- 0(=3) Advanced PIO Transfer Modes Supported '11' = PIO Mode 3 and 4 Supported
65	0078H	Minimum Multiword DMA Transfer Cycle Time Per Word 15- 0(=78h) Cycle time in nanoseconds (120 ns, 16.6 MB/s)
66	0078H	Manufacturer's Recommended Multiword DMA Transfer Cycle Time 15- 0(=78h) Cycle time in nanoseconds (120 ns, 16.6 MB/s)
67	00F0H	Minimum PIO Transfer Cycle Time Without Flow Control 15- 0(=F0h) Cycle time in nanoseconds (240 ns, 8.3 MB/s)
68	0078H	Minimum PIO Transfer Cycle Time With IORDY Flow Control 15- 0(=78h) Cycle time in nanoseconds (120 ns, 16.6 MB/s)
69-79	0000H	Reserved
80	003CH	Major version number ATA-1, ATA-2, ATA-3 and ATA/ATAPI-4, ATA/ATAPI-5
81	0013H	Minor version number ATA/ATAPI-5 T13 1321D Revision 3
82	746BH	Command set supported 15(=0) Reserved 14(=1) 1=NOP command supported 13(=1) 1=READ BUFFER command supported 12(=1) 1=WRITE BUFFER command supported 11(=0) Reserved **10(=1) 1=Host Protected Area Feature Set supported 9(=0) 1=DEVICE RESET command supported 8(=0) 1=SERVICE interrupt supported 7(=0) 1=release interrupt supported 6(=1) 1=look-ahead supported 5(=1) 1=write cache supported 4(=0) 1=supported PACKET Command Feature Set 3(=1) 1=supported Power Management Feature Set 2(=0) 1=supported Removable Media Feature Set ** 1(=1) 1=supported Security Feature Set ** 0(=1) 1=supported S.M.A.R.T. Feature Set

* in Content field indicates the use of those parameters that are vendor specific.

** indicates a feature that is able to be unsupported by the Device Configuration Overlay command.

Figure 88. Identify device information. (Part 3 of 7)

Word	Content	Description
83	49A8H	Command set supported 15(=0) Always 14(=1) Always 13-12(=0) Reserved 11(=1) 1=Device Configuration Overlay command supported 10- 9(=0) Reserved ** 8(=1) 1=SET MAX security extension supported * 7(=1) 1=Address Offset feature supported 6(=0) 1=SET FEATURES subcommand required to spin-up 5(=1) 1=Power-Up In Standby feature set supported 4(=0) 1=Removable Media Status Notification Feature Set supported 3(=1) 1=Advanced Power Management Feature Set supported 2(=0) 1=CFA Feature Set supported 1(=0) 1=READ/WRITE DMA QUEUED supported 0(=0) 1=DOWNLOAD MICROCODE command supported
84	4003H	Command set/feature supported extension 15(=0) Always 14(=1) Always 13- 2(=0) Reserved ** 1(=1) 1=SMART self-test supported ** 0(=1) 1=SMART error logging supported
85	F4XXH	Command set/feature enabled 15(=1) Reserved 14(=1) 1=NOP command supported 13(=1) 1=READ BUFFER command supported 12(=1) 1=WRITE BUFFER command supported 11(=0) Reserved **10(=1) 1=Host Protected Area Feature Set supported 9(=0) 1=DEVICE RESET command supported 8(=0) 1=SERVICE interrupt enabled 7(=0) 1=release interrupt enabled 6(=X) 1=look-ahead enabled 5(=X) 1=write cache enabled 4(=0) 1=supports PACKET Command Feature Set 3(=X) 1=supports Power Management Feature Set 2(=0) 1=supports Removable Media Feature Set 1(=X) 1=Security Feature Set enabled 0(=X) 1=S.M.A.R.T. Feature Set enabled

* in Content field indicates the use of those parameters that are vendor specific.

** indicates a feature that is able to be unsupported by the Device Configuration Overlay command.

Figure 89. Identify device information. (Part 4 of 7)

Word	Content	Description
86	0XXXH	Command set/feature enabled * 15-12(=0) Reserved 11(=1) 1=Device Configuration Overlay supported * 10- 9(=0) Reserved 8(=X) 1=SET MAX security extension enabled * 7(=X) 1=Address Offset mode enabled 6(=0) 1=SET FEATURES subcommand required to spin-up 5(=0) 1=Power-Up In Standby feature set has been enabled via the SET FEATURES command 4(=0) 1=Removable Media Status Notification Feature Set enabled 3(=X) 1=Advanced Power management Feature Set enabled 2(=0) 1=CFA Feature Set supported 1(=0) 1=READ/WRITE DMA QUEUED command supported 0(=0) 1=DOWNLOAD MICROCODE command supported
87	4003H	Command set/feature enabled 15(=0) Always 14(=1) Always 13- 2(=0) Reserved 1(=1) 1=SMART self-test supported 0(=1) 1=SMART error logging supported
88	XX3FH	Ultra DMA Transfer mode (mode 5 supported) 15-14(=0) Reserved 13(=X) 1=UltraDMA mode 5 is selected 12(=X) 1=UltraDMA mode 4 is selected 11(=X) 1=UltraDMA mode 3 is selected 10(=X) 1=UltraDMA mode 2 is selected 9(=X) 1=UltraDMA mode 1 is selected 8(=X) 1=UltraDMA mode 0 is selected 7- 6(=0) Reserved **5(=1) 1=UltraDMA mode 5 is selected **4(=1) 1=UltraDMA mode 4 is supported **3(=1) 1=UltraDMA mode 3 is supported **2(=1) 1=UltraDMA mode 2 is supported **1(=1) 1=UltraDMA mode 1 is supported 0(=1) 1=UltraDMA mode 0 is supported
89	XXXXH	Time required for security erase unit completion Time= value (XXXXh)*2 [minutes]
90	0000H	Time required for Enhance security erase completion 0000 : Not supported
91	40FEH	Reserved
92	XXXXH	Current Master Password Revision Codes

** indicates a feature that is able to be unsupported by the Device Configuration Overlay command.

Figure 90. Identify device information. (Part 5 of 7)

Word	Content	Description
93	XXXXH	<p>Hardware reset results</p> <p>15-13 Device detected result</p> <p>15(=0) Reserved</p> <p>14(=1) Always</p> <p>13(=X) 1=Device detected CBLID- above V_{ih} 0=Device detected CBLID- below V_{il}</p> <p>12- 8 Device 1 hardware reset result Device 0 clear these bits to 0</p> <p>12(=0) Reserved</p> <p>11(=X) 1=Device 1 passed diagnostic</p> <p>10-9(=X)how Device 1 determined the device number: 00=Reserved 01=a jumper was used 10=the CSEL signal was used 11=some other method used or method unknown</p> <p>8(=1) Always</p> <p>7- 0 Device 0 hardware reset result Device 1 clears these bits to 0</p> <p>7(=0) Reserved</p> <p>6(=X) 1=Semi-duplex mode is enabled</p> <p>5(=X) 1=Device 0 detected Device 1</p> <p>4(=X) 1=Device 1 passed diagnostic</p> <p>3(=X) 1=Device 0 passed diagnostic</p> <p>2-1(=X)how Device 0 determined the device number: 00=Reserved 01=a jumper was used 10=the CSEL signal was used 11=some other method used or the method unknown</p> <p>0(=1) Always</p>
94-127	0000H	Reserved
128	0XXXH	<p>Security Mode Feature. Bit assignments</p> <p>15-9(=0) Reserved</p> <p>8(=X) Security Level: 1= Maximum, 0= High</p> <p>7-6(=0) Reserved</p> <p>5(=0) 1=Enhanced security erase supported</p> <p>4(=0) 1=Security count expired</p> <p>3(=0) 1=Security Frozen</p> <p>2(=0) 1=Security Locked</p> <p>1(=0) 1=Security Enabled</p> <p>**0(=0) 1=Security Support</p>

* in Content field indicates the use of those parameters that are vendor specific.

** indicates a feature that is able to be unsupported by the Device Configuration Overlay command.

Figure 91. Identify device information. (Part 6 of 7)

Word	Content	Description
129	000XH *	Current Set Feature Option. Bit assignments 15-4(=0) Reserved 3(=X) 1=Auto reassign enabled 2(=X) 1=Reverting enabled 1(=X) 1=Read Look-ahead enabled 0(=X) 1=Write Cache enabled
130	XXXXH *	Reserved
131	000XH *	Initial Power Mode Selection. Bit assignments 15-2(=0) Reserved 1(=1) Always 0(=X) Initial Power Mode: 1=Standby, 0=Idle
132-254	0000H *	Reserved
255	XXA5H	Integrity word 15-8(=XX) Checksum 7-0(=A5) Signature

Figure 92. Identify device information. (Part 7 of 7)

Microcode revision	CAxOAxXX
---------------------------	-----------------

IC25T060ATCX05

Number of cylinders	3FFFh
Number of heads	10h
Buffer size	0DD0h (=1,768KB)
Total number of user addressable sectors	6FC7C80h

IC25N040ATCX04

Number of cylinders	3FFFh
Number of heads	10h
Buffer size	0DD0h (=1,768KB)
Total number of user addressable sectors	4A85300h

IC25N030ATCX04

Number of cylinders	3FFFh
Number of heads	10h
Buffer size	0DD0h (=1,768KB)
Total number of user addressable sectors	37E3E40h

IC25N020ATCX04

Number of cylinders	3FFFh
Number of heads	10h
Buffer size	0DD0h (=1,768KB)
Total number of user addressable sectors	2542980h

IC25N010ATCX04

Number of cylinders	3FFFh
Number of heads	10h
Buffer size	0DD0h (=1,768KB)
Total number of user addressable sectors	12BB230h

Figure 93. Number of cylinders/heads/sectors by model.

For the microcode revision refer to 13.8, "Identify Device (ECh)" on page 118. This is 8 characters in ASCII.

13.9 Idle (E3h/97h)

Command Block Output Registers								Command Block Input Registers									
Register	7	6	5	4	3	2	1	0	Register	7	6	5	4	3	2	1	0
Data	-	-	-	-	-	-	-	-	Data	-	-	-	-	-	-	-	-
Feature	-	-	-	-	-	-	-	-	Error	see below							
Sector Count	V	V	V	V	V	V	V	V	Sector Count	-	-	-	-	-	-	-	-
Sector Number	-	-	-	-	-	-	-	-	Sector Number	-	-	-	-	-	-	-	-
Cylinder Low	-	-	-	-	-	-	-	-	Cylinder Low	-	-	-	-	-	-	-	-
Cylinder High	-	-	-	-	-	-	-	-	Cylinder High	-	-	-	-	-	-	-	-
Device/Head	1	-	1	D	-	-	-	-	Device/Head	-	-	-	-	-	-	-	-
Command	1	1	1	0	0	0	1	1	Status	see below							

Error Register							
7	6	5	4	3	2	1	0
CRC	UNC	0	IDN	0	ABT	T0N	AMN
0	0	0	0	0	V	0	0

Status Register							
7	6	5	4	3	2	1	0
BSY	RDY	DF	DSC	DRQ	COR	IDX	ERR
0	V	0	V	-	0	-	V

Figure 94. Idle command (E3h/97h)

When the power save mode is Standby mode, the Idle command causes the device to enter Performance Idle mode immediately and sets the auto power down time-out Parameter (standby timer). At the set of the auto power down time-out parameter (standby timer) the point timer starts counting down. When the power save mode is already in idle mode, the device remains in that mode.

When the Idle mode is entered, the device is spun up to operating speed. If the device is already spinning, the spin up sequence is not executed.

During Idle mode the device is spinning and is ready to respond to host commands immediately.

Input parameters to the device

Sector Count This indicates the Time-out Parameter. If it is zero, the time-out interval (Standby Timer) is NOT disabled and the time-out interval is set automatically for 109 minutes. If it is other than zero, the time-out interval is set for (Time-out Parameter × 5) seconds.

The device will enter Standby mode automatically if the time-out interval expires with no device access from the host. The time-out interval will be reinitialized if there is a device access before the time-out interval expires.

13.10 Idle Immediate (E1h/95h)

Command Block Output Registers								Command Block Input Registers									
Register	7	6	5	4	3	2	1	0	Register	7	6	5	4	3	2	1	0
Data	-	-	-	-	-	-	-	-	Data	-	-	-	-	-	-	-	-
Feature	-	-	-	-	-	-	-	-	Error	see below							
Sector Count	-	-	-	-	-	-	-	-	Sector Count	-	-	-	-	-	-	-	-
Sector Number	-	-	-	-	-	-	-	-	Sector Number	-	-	-	-	-	-	-	-
Cylinder Low	-	-	-	-	-	-	-	-	Cylinder Low	-	-	-	-	-	-	-	-
Cylinder High	-	-	-	-	-	-	-	-	Cylinder High	-	-	-	-	-	-	-	-
Device/Head	1	-	1	D	-	-	-	-	Device/Head	-	-	-	-	-	-	-	-
Command	1	1	1	0	0	0	0	1	Status	see below							

Error Register							
7	6	5	4	3	2	1	0
CRC	UNC	0	IDN	0	ABT	T0N	AMN
0	0	0	0	0	V	0	0

Status Register							
7	6	5	4	3	2	1	0
BSY	RDY	DF	DSC	DRQ	COR	IDX	ERR
0	V	0	V	-	0	-	V

Figure 95. Idle Immediate command (E1h/95h)

The Idle Immediate command causes the device to enter Performance Idle mode.

The device is spun up to operating speed. If the device is already spinning, the spin up sequence is not executed.

During Idle mode the device is spinning and ready to respond to the host commands immediately.

The Idle Immediate command will not affect the auto power down time-out parameter.

13.11 Initialize Device Parameters (91h)

Command Block Output Registers								Command Block Input Registers									
Register	7	6	5	4	3	2	1	0	Register	7	6	5	4	3	2	1	0
Data	-	-	-	-	-	-	-	-	Data	-	-	-	-	-	-	-	-
Feature	-	-	-	-	-	-	-	-	Error	-	-	-	-	-	-	-	-
Sector Count	V	V	V	V	V	V	V	V	Sector Count	-	-	-	-	-	-	-	-
Sector Number	-	-	-	-	-	-	-	-	Sector Number	-	-	-	-	-	-	-	-
Cylinder Low	-	-	-	-	-	-	-	-	Cylinder Low	-	-	-	-	-	-	-	-
Cylinder High	-	-	-	-	-	-	-	-	Cylinder High	-	-	-	-	-	-	-	-
Device/Head	1	-	1	D	H	H	H	H	Device/Head	-	-	-	-	-	-	-	-
Command	1	0	0	1	0	0	0	1	Status	see below							

Error Register							
7	6	5	4	3	2	1	0
CRC	UNC	0	IDN	0	ABT	T0N	AMN
0	0	0	0	0	V	0	0

Status Register							
7	6	5	4	3	2	1	0
BSY	RDY	DF	DSC	DRQ	COR	IDX	ERR
0	0	0	-	-	0	-	V

Figure 96. Initialize Device Parameters command (91h)

The Initialize Device Parameters command enables the host to set the number of sectors per track and the number of heads minus 1, per cylinder. Words 54–58 in Identify Device Information reflects these parameters.

The parameters remain in effect until the following events occur:

- Another Initialize Device Parameters command is received.
- The device is powered off.
- A hard reset occurs.
- A soft reset occurs and the Set Feature option of CCh is set.

Input parameters to the device

Sector Count This indicates the number of sectors per track. Zero (0) does not mean that there are 256 sectors per track. It means that there are no sectors per track.

H This indicates the number of heads minus 1 per cylinder. The minimum is 0 and the maximum is 15.

13.12 Read Buffer (E4h)

Command Block Output Registers								Command Block Input Registers									
Register	7	6	5	4	3	2	1	0	Register	7	6	5	4	3	2	1	0
Data	-	-	-	-	-	-	-	-	Data	-	-	-	-	-	-	-	-
Feature	-	-	-	-	-	-	-	-	Error	see below							
Sector Count	-	-	-	-	-	-	-	-	Sector Count	-	-	-	-	-	-	-	-
Sector Number	-	-	-	-	-	-	-	-	Sector Number	-	-	-	-	-	-	-	-
Cylinder Low	-	-	-	-	-	-	-	-	Cylinder Low	-	-	-	-	-	-	-	-
Cylinder High	-	-	-	-	-	-	-	-	Cylinder High	-	-	-	-	-	-	-	-
Device/Head	1	-	1	D	-	-	-	-	Device/Head	-	-	-	-	-	-	-	-
Command	1	1	1	0	0	1	0	0	Status	see below							

Error Register							
7	6	5	4	3	2	1	0
CRC	UNC	0	IDN	0	ABT	T0N	AMN
0	0	0	0	0	V	0	0

Status Register							
7	6	5	4	3	2	1	0
BSY	RDY	DF	DSC	DRQ	COR	IDX	ERR
0	V	0	-	-	0	-	V

Figure 97. Read Buffer command (E4h)

The Read Buffer command transfers a sector of data from the sector buffer of the device to the host.

The sector is transferred through the Data Register 16 bits at a time.

The sector transferred will be from the same part of the buffer written to by the last Write Buffer command. The contents of the sector may be different if any reads or writes have occurred since the Write Buffer command was issued.

13.13 Read DMA (C8h/C9h)

Command Block Output Registers								Command Block Input Registers									
Register	7	6	5	4	3	2	1	0	Register	7	6	5	4	3	2	1	0
Data	-	-	-	-	-	-	-	-	Data	-	-	-	-	-	-	-	-
Feature	-	-	-	-	-	-	-	-	Error	see below							
Sector Count	V	V	V	V	V	V	V	V	Sector Count	V	V	V	V	V	V	V	V
Sector Number	V	V	V	V	V	V	V	V	Sector Number	V	V	V	V	V	V	V	V
Cylinder Low	V	V	V	V	V	V	V	V	Cylinder Low	V	V	V	V	V	V	V	V
Cylinder High	V	V	V	V	V	V	V	V	Cylinder High	V	V	V	V	V	V	V	V
Device/Head	1	L	1	D	H	H	H	H	Device/Head	-	-	-	-	H	H	H	H
Command	1	1	0	0	1	0	0	R	Status	see below							

Error Register							
7	6	5	4	3	2	1	0
CRC	UNC	0	IDN	0	ABT	T0N	AMN
V	V	0	V	0	V	0	V

Status Register							
7	6	5	4	3	2	1	0
BSY	RDY	DF	DSC	DRQ	COR	IDX	ERR
0	V	0	V	-	0	-	V

Figure 98. Read DMA command (C8h/C9h)

The Read DMA command reads one or more sectors of data from disk media and then transfers the data from the device to the host. It transfers the sectors through the Data Register 16 bits at a time.

The host initializes a slave-DMA channel prior to issuing the command. The data transfers are qualified by the DMARQ and are performed by the slave-DMA channel. The device issues only one interrupt per command to indicate that the data transfer has terminated and that status is available.

If an uncorrectable error occurs, the read will be terminated at the failing sector.

Output parameters to the device

- Sector Count** This indicates the number of continuous sectors to be transferred. If zero is specified, then 256 sectors will be transferred.
- Sector Number** This indicates the sector number of the first sector to be transferred. (L = 0). In LBA mode, this register specifies that LBA address bits 0–7 are to be transferred. (L = 1)
- Cylinder High/Low** This indicates the cylinder number of the first sector to be transferred. (L = 0) In LBA mode, this register specifies LBA address bits 8–15 (Low) and 16–23 (High) to be transferred. (L = 1)
- H** This indicates the head number of the first sector to be transferred. (L = 0) In LBA mode this register specifies the LBA bits 24–27 to be transferred. (L = 1)
- R** This indicates the retry bit, but this bit is ignored.

Input parameters from the device

Sector Count	This indicates the number of requested sectors not transferred. This will be zero, unless an unrecoverable error occurs.
Sector Number	This indicates the sector number of the last transferred sector. (L = 0) In LBA mode this register contains the current LBA bits 0–7. (L = 1)
Cylinder High/Low	This indicates the cylinder number of the last transferred sector. (L = 0) In LBA mode this register contains the current LBA bits 8–15 (Low) and bits 16–23 (High). (L = 1)
H	This indicates the head number of the sector to be transferred. (L = 0) In LBA mode this register contains the current LBA bits 24–27. (L = 1)

13.14 Read Long (22h/23h)

Command Block Output Registers								Command Block Input Registers									
Register	7	6	5	4	3	2	1	0	Register	7	6	5	4	3	2	1	0
Data	-	-	-	-	-	-	-	-	Data	-	-	-	-	-	-	-	-
Feature	-	-	-	-	-	-	-	-	Error	see below							
Sector Count	0	0	0	0	0	0	0	1	Sector Count	-	-	-	-	-	-	-	V
Sector Number	V	V	V	V	V	V	V	V	Sector Number	V	V	V	V	V	V	V	V
Cylinder Low	V	V	V	V	V	V	V	V	Cylinder Low	V	V	V	V	V	V	V	V
Cylinder High	V	V	V	V	V	V	V	V	Cylinder High	V	V	V	V	V	V	V	V
Device/Head	1	L	1	D	H	H	H	H	Device/Head	-	-	-	-	H	H	H	H
Command	0	0	1	0	0	0	1	R	Status	see below							

Error Register							
7	6	5	4	3	2	1	0
CRC	UNC	0	IDN	0	ABT	T0N	AMN
0	0	0	V	0	V	0	V

Status Register							
7	6	5	4	3	2	1	0
BSY	RDY	DF	DSC	DRQ	COR	IDX	ERR
0	V	0	V	0	0	-	V

Figure 99. Read Long command (22h/23h)

The Read Long command reads the designated one sector of data and the ECC bytes from the disk media. It then transfers the data and ECC bytes from the device to the host.

After 512 bytes of data have been transferred, the device will keep setting DRQ = 1 to indicate that the device is ready to transfer the ECC bytes to the host. The data is transferred 16 bits at a time and the ECC bytes are transferred 8 bits at a time. The number of ECC bytes are 4 or 40 according to the setting of Set Feature option. The default setting is 4 bytes of ECC data.

The command makes a single attempt to read the data and does not check the data using ECC. Whatever is read is returned to the host.

Output parameters to the device

- Sector Count** This indicates the number of continuous sectors to be transferred. The Sector Count must be set to one.
- Sector Number** This indicates the sector number of the sector to be transferred. (L = 0) In LBA mode, this register contains LBA bits 0–7. (L = 1)
- Cylinder High/Low** This indicates the cylinder number of the sector to be transferred. (L = 0) In LBA mode, this register contains LBA bits 8–15 (Low), 16–23 (High). (L = 1)
- H** This indicates the head number of the sector to be transferred. (L = 0) In LBA mode, this register contains LBA bits 24–27. (L = 1)
- R** This indicates the retry bit, but this bit is ignored.

Input parameters from the device

Sector Count	This indicates the number of requested sectors not transferred.
Sector Number	This indicates the sector number of the transferred sector. (L = 0) In LBA mode, this register contains current LBA bits 0–7. (L = 1)
Cylinder High/Low	This indicates the cylinder number of the transferred sector. (L = 0) In LBA mode, this register contains current LBA bits 8–15 (Low), 16–23 (High). (L = 1)
H	This indicates the head number of the transferred sector. (L = 0) In LBA mode, this register contains current LBA bits 24–27. (L = 1)

The device internally uses 40 bytes of ECC data on all data written or read from the disk. The 4 byte mode of operation is provided via an emulation. Use of the 40 byte ECC mode is recommended for testing the effectiveness and integrity of the ECC functions of the device.

13.15 Read Multiple (C4h)

Command Block Output Registers								Command Block Input Registers									
Register	7	6	5	4	3	2	1	0	Register	7	6	5	4	3	2	1	0
Data	-	-	-	-	-	-	-	-	Data	-	-	-	-	-	-	-	-
Feature	-	-	-	-	-	-	-	-	Error	see below							
Sector Count	V	V	V	V	V	V	V	V	Sector Count	V	V	V	V	V	V	V	V
Sector Number	V	V	V	V	V	V	V	V	Sector Number	V	V	V	V	V	V	V	V
Cylinder Low	V	V	V	V	V	V	V	V	Cylinder Low	V	V	V	V	V	V	V	V
Cylinder High	V	V	V	V	V	V	V	V	Cylinder High	V	V	V	V	V	V	V	V
Device/Head	1	L	1	D	H	H	H	H	Device/Head	-	-	-	-	H	H	H	H
Command	1	1	0	0	0	1	0	0	Status	see below							

Error Register							
7	6	5	4	3	2	1	0
CRC	UNC	0	IDN	0	ABT	T0N	AMN
0	V	0	V	0	V	0	V

Status Register							
7	6	5	4	3	2	1	0
BSY	RDY	DF	DSC	DRQ	COR	IDX	ERR
0	V	0	V	-	0	-	V

Figure 100. Read Multiple command (C4h)

The Read Multiple command reads one or more sectors of data from disk media and then transfers the data from the device to the host.

The sectors are transferred through the Data Register 16 bits at a time. The command execution is identical to the Read Sectors command with one exception: an interrupt is generated for each block—as defined by the Set Multiple command—instead of for each sector.

Output parameters to the device

- Sector Count** This indicates the number of continuous sectors to be transferred. If zero is specified, 256 sectors will be transferred.
- Sector Number** This indicates the sector number of the first sector to be transferred. (L = 0) In LBA mode, this register contains LBA bits 0–7. (L = 1)
- Cylinder High/Low** This indicates the cylinder number of the first sector to be transferred. (L = 0) In LBA mode this register contains LBA bits 8–15 (Low) and bits 16–23 (High). (L = 1)
- H** This indicates the head number of the first sector to be transferred. (L = 0) In LBA mode this register contains LBA bits 24–27. (L = 1)

Input parameters from the device

Sector Count	This indicates the number of requested sectors not transferred. This number is zero unless an unrecoverable error occurs.
Sector Number	This indicates the sector number of the last transferred sector. (L = 0) In LBA mode, this register contains the current LBA bits 0–7. (L = 1)
Cylinder High/Low	This indicates the cylinder number of the last transferred sector. (L = 0) In LBA mode, this register contains the current LBA bits 8–15 (Low) and bits 16–23 (High). (L = 1)
H	This indicates the head number of the last transferred sector. (L = 0) In LBA mode this register contains the current LBA bits 24–27. (L = 1)

13.16 Read Native Max ADDRESS (F8h)

Command Block Output Registers								Command Block Input Registers									
Register	7	6	5	4	3	2	1	0	Register	7	6	5	4	3	2	1	0
Data	-	-	-	-	-	-	-	-	Data	-	-	-	-	-	-	-	-
Feature	-	-	-	-	-	-	-	-	Error	see below							
Sector Count	-	-	-	-	-	-	-	-	Sector Count	-	-	-	-	-	-	-	-
Sector Number	-	-	-	-	-	-	-	-	Sector Number	V	V	V	V	V	V	V	V
Cylinder Low	-	-	-	-	-	-	-	-	Cylinder Low	V	V	V	V	V	V	V	V
Cylinder High	-	-	-	-	-	-	-	-	Cylinder High	V	V	V	V	V	V	V	V
Device/Head	1	L	1	D	-	-	-	-	Device/Head	-	-	-	-	H	H	H	H
Command	1	1	1	1	1	0	0	0	Status	see below							

Error Register							
7	6	5	4	3	2	1	0
CRC	UNC	0	IDN	0	ABT	T0N	AMN
0	0	0	0	0	V	0	0

Status Register							
7	6	5	4	3	2	1	0
BSY	RDY	DF	DSC	DRQ	COR	IDX	ERR
0	V	0	-	-	0	-	V

Figure 101. Read Native Max ADDRESS (F8h)

This command returns the native max LBA/CYL of the drive which is not effected by the Set Max ADDRESS command. Even if the Address Offset mode is enabled, the native max LBA/CYL is returned.

Output parameters to the device

- L** LBA mode. This indicates the addressing mode. L = 0 specifies CHS mode and L = 1 specifies the LBA addressing mode.
- D** This is the device number bit. Indicates that the device number bit of the Device/Head Register should be specified. D = 0 selects the master device and D = 1 selects the slave device.
- Indicates that the bit is not used.

Input parameters from the device

- Sector Number** In LBA mode this register contains the native max LBA bits 0–7. (L = 1)
In CHS mode this register contains the native max sector number. (L = 0)
- Cylinder High/Low** In LBA mode this register contains the native max LBA bits 8–15 (Low) and bits 16–23 (High). (L = 1)
In CHS mode this register contains the native max cylinder number. (L = 0)
- H** In LBA mode this register contains the native max LBA bits 24–27. (L = 1) In CHS mode this register contains the native maximum head number. (L = 0)

- V** Valid. Indicates that the bit is part of an input parameter and will be set to 0 or 1 by the device.
- This indicates that the bit is not used.

13.17 Read Sectors (20h/21h)

Command Block Output Registers								Command Block Input Registers									
Register	7	6	5	4	3	2	1	0	Register	7	6	5	4	3	2	1	0
Data	-	-	-	-	-	-	-	-	Data	-	-	-	-	-	-	-	-
Feature	-	-	-	-	-	-	-	-	Error	see below							
Sector Count	V	V	V	V	V	V	V	V	Sector Count	V	V	V	V	V	V	V	V
Sector Number	V	V	V	V	V	V	V	V	Sector Number	V	V	V	V	V	V	V	V
Cylinder Low	V	V	V	V	V	V	V	V	Cylinder Low	V	V	V	V	V	V	V	V
Cylinder High	V	V	V	V	V	V	V	V	Cylinder High	V	V	V	V	V	V	V	V
Device/Head	1	L	1	D	H	H	H	H	Device/Head	-	-	-	-	H	H	H	H
Command	0	0	1	0	0	0	0	R	Status	see below							

Error Register							
7	6	5	4	3	2	1	0
CRC	UNC	0	IDN	0	ABT	T0N	AMN
0	V	0	V	0	V	0	V

Status Register							
7	6	5	4	3	2	1	0
BSY	RDY	DF	DSC	DRQ	COR	IDX	ERR
0	V	0	V	-	0	-	V

Figure 102. Read Sectors command (20h/21h)

The Read Sectors command reads one or more sectors of data from disk media and then transfers the data from the device to the host.

The sectors are transferred through the Data Register 16 bits at a time. If an uncorrectable error occurs the read will be terminated at the failing sector.

Output parameters to the device

- Sector Count** This indicates the number of continuous sectors to be transferred. If zero is specified, then 256 sectors will be transferred.
- Sector Number** This is the sector number of the first sector to be transferred. (L = 0)
In LBA mode this register contains the LBA bits 0–7. (L = 1)
- Cylinder High/Low** This is the cylinder number of the first sector to be transferred. (L = 0)
In LBA mode this register contains the LBA bits 8–15 (Low) and bits 16–23 (High). (L = 1)
- H** This is the head number of the first sector to be transferred. (L = 0)
In LBA mode this register contains the LBA bits 24–27. (L = 1)
- R** This is the retry bit, but this bit is ignored.

Input parameters from the device

Sector Count	This is the number of requested sectors not transferred. This will be zero, unless an unrecoverable error occurs.
Sector Number	This is the sector number of the last transferred sector. (L = 0) In LBA mode this register contains the current LBA bits 0–7. (L = 1)
Cylinder High/Low	This is the cylinder number of the last transferred sector. (L = 0) In LBA mode this register contains the current LBA bits 8–15 (Low) and bits 16–23 (High). (L = 1)
H	This is the head number of the last transferred sector. (L = 0) In LBA mode this register contains the current LBA bits 24–27. (L = 1)

13.18 Read Verify Sectors (40h/41h)

Command Block Output Registers								Command Block Input Registers									
Register	7	6	5	4	3	2	1	0	Register	7	6	5	4	3	2	1	0
Data	-	-	-	-	-	-	-	-	Data	-	-	-	-	-	-	-	-
Feature	-	-	-	-	-	-	-	-	Error	see below							
Sector Count	V	V	V	V	V	V	V	V	Sector Count	V	V	V	V	V	V	V	V
Sector Number	V	V	V	V	V	V	V	V	Sector Number	V	V	V	V	V	V	V	V
Cylinder Low	V	V	V	V	V	V	V	V	Cylinder Low	V	V	V	V	V	V	V	V
Cylinder High	V	V	V	V	V	V	V	V	Cylinder High	V	V	V	V	V	V	V	V
Device/Head	1	L	1	D	H	H	H	H	Device/Head	-	-	-	-	H	H	H	H
Command	0	0	1	0	0	0	0	R	Status	see below							

Error Register							
7	6	5	4	3	2	1	0
CRC	UNC	0	IDN	0	ABT	T0N	AMN
0	V	0	V	0	V	0	V

Status Register							
7	6	5	4	3	2	1	0
BSY	RDY	DF	DSC	DRQ	COR	IDX	ERR
0	V	0	V	-	0	-	V

Figure 103. Read Verify Sectors command (40h/41h)

The Read Verify Sectors command verifies one or more sectors on the device. No data is transferred to the host.

The difference between the Read Sectors command and Read Verify Sectors command is that data is transferred to the host during a Read Sectors command and data is not transferred to the host during a Read Verify Sectors command.

If an uncorrectable error occurs, the read verify will be terminated at the failing sector.

Output parameters to the device

Sector Count This is the number of continuous sectors to be verified. If zero is specified, 256 sectors will be verified.

Sector Number This is the sector number of the first sector to be transferred. (L = 0)
In LBA mode this register contains the LBA bits 0–7. (L = 1)

Cylinder High/Low This is the cylinder number of the first sector to be transferred. (L = 0)
In LBA mode this register contains the LBA bits 8–15 (Low) and bits 16–23 (High). (L = 1)

H This is the head number of the first sector to be transferred. (L = 0)
In LBA mode this register contains the LBA bits 24–27. (L = 1)

R This is the retry bit, but this bit is ignored.

Input parameters from the device

Sector Count	This is the number of requested sectors not verified. This number will be zero unless an unrecoverable error occurs.
Sector Number	This is the sector number of the last transferred sector. (L = 0) In LBA mode this register contains the current LBA bits 0–7. (L = 1)
Cylinder High/Low	This is the cylinder number of the last transferred sector. (L = 0) In LBA mode this register contains the current LBA bits 8–15 (Low) and bits 16–23 (High). (L = 1)
H	This is the head number of the last transferred sector. (L = 0) In LBA mode this register contains the current LBA bits 24–27. (L = 1)

13.19 Recalibrate (1xh)

Command Block Output Registers								Command Block Input Registers									
Register	7	6	5	4	3	2	1	0	Register	7	6	5	4	3	2	1	0
Data	-	-	-	-	-	-	-	-	Data	-	-	-	-	-	-	-	-
Feature	-	-	-	-	-	-	-	-	Error	see below							
Sector Count	-	-	-	-	-	-	-	-	Sector Count	-	-	-	-	-	-	-	-
Sector Number	-	-	-	-	-	-	-	-	Sector Number	-	-	-	-	-	-	-	-
Cylinder Low	-	-	-	-	-	-	-	-	Cylinder Low	-	-	-	-	-	-	-	-
Cylinder High	-	-	-	-	-	-	-	-	Cylinder High	-	-	-	-	-	-	-	-
Device/Head	1	-	1	D	-	-	-	-	Device/Head	-	-	-	-	-	-	-	
Command	0	0	0	1	-	-	-	-	Status	see below							

Error Register							
7	6	5	4	3	2	1	0
CRC	UNC	0	IDN	0	ABT	T0N	AMN
0	0	0	0	0	V	V	0

Status Register							
7	6	5	4	3	2	1	0
BSY	RDY	DF	DSC	DRQ	COR	IDX	ERR
0	V	0	V	-	0	-	V

Figure 104. Recalibrate command (1xh)

The Recalibrate command moves the read/write heads from anywhere on the disk to cylinder 0. If the device cannot reach cylinder 0, T0N (Track 0 Not Found) will be set in the Error Register.

13.20 Security Disable Password (F6h)

Command Block Output Registers								Command Block Input Registers									
Register	7	6	5	4	3	2	1	0	Register	7	6	5	4	3	2	1	0
Data	-	-	-	-	-	-	-	-	Data	-	-	-	-	-	-	-	-
Feature	-	-	-	-	-	-	-	-	Error	see below							
Sector Count	-	-	-	-	-	-	-	-	Sector Count	-	-	-	-	-	-	-	-
Sector Number	-	-	-	-	-	-	-	-	Sector Number	-	-	-	-	-	-	-	-
Cylinder Low	-	-	-	-	-	-	-	-	Cylinder Low	-	-	-	-	-	-	-	-
Cylinder High	-	-	-	-	-	-	-	-	Cylinder High	-	-	-	-	-	-	-	-
Device/Head	1	-	1	D	-	-	-	-	Device/Head	-	-	-	-	-	-	-	-
Command	1	1	1	1	0	1	1	0	Status	see below							

Error Register							
7	6	5	4	3	2	1	0
CRC	UNC	0	IDN	0	ABT	T0N	AMN
0	0	0	0	0	V	0	0

Status Register							
7	6	5	4	3	2	1	0
BSY	RDY	DF	DSC	DRQ	COR	IDX	ERR
0	V	0	V	-	0	-	V

Figure 105. Security Disable Password command (F6h)

The Security Disable Password command disables the security mode feature (device lock function).

The Security Disable Password command requests a transfer of a single sector of data from the host including information specified in Figure 106. The device then checks the transferred password. If the User Password or Master Password matches the given password, the device disables the security mode feature (device lock function). This command does not change the Master Password which may be reactivated later by setting User Password. This command should be executed in device unlock mode.

Word	Description
00	Control word bit 0 : Identifier (1–Master, 0–User) bits 1–15 : Reserved
01–16	Password (32 bytes)
17–255	Reserved

Figure 106. Password Information for Security Disable Password command

The device will compare the password sent from this host with that specified in the control word.

Identifier Zero indicates that the device should check the supplied password against the user password stored internally. One indicates that the device should check the given password against the master password stored internally.

13.21 Security Erase Prepare (F3h)

Command Block Output Registers								Command Block Input Registers									
Register	7	6	5	4	3	2	1	0	Register	7	6	5	4	3	2	1	0
Data	-	-	-	-	-	-	-	-	Data	-	-	-	-	-	-	-	-
Feature	-	-	-	-	-	-	-	-	Error	see below							
Sector Count	-	-	-	-	-	-	-	-	Sector Count	-	-	-	-	-	-	-	-
Sector Number	-	-	-	-	-	-	-	-	Sector Number	-	-	-	-	-	-	-	-
Cylinder Low	-	-	-	-	-	-	-	-	Cylinder Low	-	-	-	-	-	-	-	-
Cylinder High	-	-	-	-	-	-	-	-	Cylinder High	-	-	-	-	-	-	-	-
Device/Head	1	-	1	D	-	-	-	-	Device/Head	-	-	-	-	-	-	-	-
Command	1	1	1	1	0	0	1	1	Status	see below							

Error Register							
7	6	5	4	3	2	1	0
CRC	UNC	0	IDN	0	ABT	T0N	AMN
0	0	0	0	0	V	0	0

Status Register							
7	6	5	4	3	2	1	0
BSY	RDY	DF	DSC	DRQ	COR	IDX	ERR
0	V	0	V	-	0	-	V

Figure 107. Security Erase Prepare command (F3h)

The Security Erase Prepare command must be issued immediately before the Security Erase Unit command to enable device erasing and unlocking.

The Security Erase Prepare Command must be issued immediately before the Format Unit Command. This command is to prevent accidental erasure of the device.

This command does not request the transfer of data.

13.22 Security Erase Unit (F4h)

Command Block Output Registers								Command Block Input Registers									
Register	7	6	5	4	3	2	1	0	Register	7	6	5	4	3	2	1	0
Data	-	-	-	-	-	-	-	-	Data	-	-	-	-	-	-	-	-
Feature	-	-	-	-	-	-	-	-	Error	see below							
Sector Count	-	-	-	-	-	-	-	-	Sector Count	-	-	-	-	-	-	-	-
Sector Number	-	-	-	-	-	-	-	-	Sector Number	-	-	-	-	-	-	-	-
Cylinder Low	-	-	-	-	-	-	-	-	Cylinder Low	-	-	-	-	-	-	-	-
Cylinder High	-	-	-	-	-	-	-	-	Cylinder High	-	-	-	-	-	-	-	-
Device/Head	1	-	1	D	-	-	-	-	Device/Head	-	-	-	-	-	-	-	-
Command	1	1	1	1	0	1	0	0	Status	see below							

Error Register							
7	6	5	4	3	2	1	0
CRC	UNC	0	IDN	0	ABT	T0N	AMN
0	0	0	V	0	V	0	0

Status Register							
7	6	5	4	3	2	1	0
BSY	RDY	DF	DSC	DRQ	COR	IDX	ERR
0	V	0	V	-	0	-	V

Figure 108. Security Erase Unit command (F4h)

The Security Erase Unit command initializes all user data sectors and then disables the device lock function.

Note that the Security Erase Unit command initializes from LBA 0 to Native MAX LBA. The Host MAX LBA is set by the Initialize Drive Parameter or the Set MAX ADDRESS command is ignored. The protected area by the Set MAX ADDRESS command is also initialized.

This command requests the transfer of a single sector of data from the host including information specified in Figure 109.

If the password does not match, the device rejects the command with an Aborted error.

Word	Description
00	Control Word bit 0 : Identifier (1- Master, 0- User) bit 1-15 : Reserved
01-16	Password (32 bytes)
17-255	Reserved

Figure 109. Erase Unit information

Identifier Zero indicates that the device should check the supplied password against the user password stored internally. One indicates that the device should check the given password against the master password stored internally.

The Security Erase Unit command erases all user data and disables the security mode feature (device lock function). After completing of this command, all the user data will be initialized to zero with a write operation. At this time, the data write is not verified with a read operation to determine if the data sector is initialized correctly. At this time the defective sector information and the reassigned sector information for the device are not updated. The security erase prepare command should be completed immediately prior to the Security Erase Unit command. If the device receives a Security Erase Unit command without a prior Security Erase Prepare command the device aborts the security erase unit command.

This command disables the security mode feature (device lock function), however, the master password is still stored internally within the device and may be reactivated later when a new user password is set. If you execute this command on disabling the security mode feature (device lock function), the password sent by the host is NOT compared with the Master Password and the User Password. The device only erases all user data.

The execution time of this command is shown below.

IC25T060ATCX05	60 min
IC25N040ATCX04	44 min
IC25N030ATCX04	34 min
IC25N020ATCX04	22 min
IC25N010ATCX04	12 min

13.23 Security Freeze Lock (F5h)

Command Block Output Registers								Command Block Input Registers									
Register	7	6	5	4	3	2	1	0	Register	7	6	5	4	3	2	1	0
Data	-	-	-	-	-	-	-	-	Data	-	-	-	-	-	-	-	-
Feature	-	-	-	-	-	-	-	-	Error	see below							
Sector Count	-	-	-	-	-	-	-	-	Sector Count	-	-	-	-	-	-	-	-
Sector Number	-	-	-	-	-	-	-	-	Sector Number	-	-	-	-	-	-	-	-
Cylinder Low	-	-	-	-	-	-	-	-	Cylinder Low	-	-	-	-	-	-	-	-
Cylinder High	-	-	-	-	-	-	-	-	Cylinder High	-	-	-	-	-	-	-	-
Device/Head	1	-	1	D	-	-	-	-	Device/Head	-	-	-	-	-	-	-	-
Command	1	1	1	1	0	1	0	1	Status	see below							

Error Register							
7	6	5	4	3	2	1	0
CRC	UNC	0	IDN	0	ABT	T0N	AMN
0	0	0	0	0	V	0	0

Status Register							
7	6	5	4	3	2	1	0
BSY	RDY	DF	DSC	DRQ	COR	IDX	ERR
0	V	0	-	-	0	-	V

Figure 110. Security Freeze Lock command (F5h)

The Security Freeze Lock Command allows the device to enter frozen mode immediately.

After this command is completed, the command which updates Security Mode Feature (Device Lock Function) is rejected.

Frozen mode is quit only by a Power off.

The following commands are rejected when the device is in frozen mode. Refer to Figure 66 on pages 86 and 87

- Security Set Password
- Security Unlock
- Security Disable Password
- Security Erase Unit

13.24 Security Set Password (F1h)

Command Block Output Registers								Command Block Input Registers									
Register	7	6	5	4	3	2	1	0	Register	7	6	5	4	3	2	1	0
Data	-	-	-	-	-	-	-	-	Data	-	-	-	-	-	-	-	-
Feature	-	-	-	-	-	-	-	-	Error	see below							
Sector Count	-	-	-	-	-	-	-	-	Sector Count	-	-	-	-	-	-	-	-
Sector Number	-	-	-	-	-	-	-	-	Sector Number	-	-	-	-	-	-	-	-
Cylinder Low	-	-	-	-	-	-	-	-	Cylinder Low	-	-	-	-	-	-	-	-
Cylinder High	-	-	-	-	-	-	-	-	Cylinder High	-	-	-	-	-	-	-	-
Device/Head	1	-	1	D	-	-	-	-	Device/Head	-	-	-	-	-	-	-	-
Command	1	1	1	1	0	0	0	1	Status	see below							

Error Register							
7	6	5	4	3	2	1	0
CRC	UNC	0	IDN	0	ABT	T0N	AMN
0	0	0	0	0	V	0	0

Status Register							
7	6	5	4	3	2	1	0
BSY	RDY	DF	DSC	DRQ	COR	IDX	ERR
0	V	0	-	-	0	-	V

Figure 111. Security Set Password command (F1h)

The Security Set Password command enables the security mode feature (device lock function) and sets the master password or the user password.

The security mode feature (device lock function) is enabled by this command and the device is not locked immediately. The device is locked after the next power on reset or hard reset. When the MASTER password is set by this command, the master password is registered internally. The device is NOT locked after next power on reset or hard reset.

This command requests a transfer of a single sector of data from the host including the information specified in Figure 112 on page 150.

The data transferred controls the function of this command.

Word	Description
00	Control Word bit 0 : Identifier (1-Master, 0-User) bit 1-7 : Reserved bit 8 : Security level (1-Maximum, 0-High) bit 9-15 : Reserved
01-16	Password (32 bytes)
17-18	Master Password Revision Code (valid if Word 0 bit 0 = 1)
19-255	Reserved

Figure 112. Security Set Password information

Identifier Zero indicates that the device should check the supplied password against the user password stored internally. One indicates that the device should check the given password against the master password stored internally.

Security Level A zero indicates a High level, a one indicates a Maximum level. If the host sets the High level and the password is forgotten then the Master Password can be used to unlock the device. If the host sets the Maximum level and the user password is forgotten, only a Security Erase Prepare/Security Unit command can unlock the device and all data will be lost.

Password The 32 bytes are always significant in the text of the password.

Master Password Revision Code

The Revision Code field is set with Master password. If Identifier is User, the Revision Code is not set. The Revision Code field is returned in Identify Device word 92. The valid Revision Codes are 0000h to FFFDh. The Default Master Password Revision Code is FFFEh. The code FFFFh is reserved.

The setting of the Identifier and Security level bits interact as follows:

Identifier = User / Security level = High

The password supplied with the command will be saved as the new user password. The security mode feature (lock function) will be enabled from the next power on. The drive may then be unlocked by either the user password or the previously set master password.

Identifier = Master / Security level = High

This combination will set a master password but will NOT enable the security mode feature (lock function).

Identifier = User / Security level = Maximum

The password supplied with the command will be saved as the new user password. The security mode feature (lock function) will be enabled from the next power on. The drive may then be unlocked by only the user password. The master password previously set is still stored in the drive but may NOT be used to unlock the device.

Identifier = Master / Security level = Maximum

This combination will set a master password but will NOT enable the security mode feature (lock function).

13.25 Security Unlock (F2h)

Command Block Output Registers								Command Block Input Registers									
Register	7	6	5	4	3	2	1	0	Register	7	6	5	4	3	2	1	0
Data	-	-	-	-	-	-	-	-	Data	-	-	-	-	-	-	-	-
Feature	-	-	-	-	-	-	-	-	Error	see below							
Sector Count	-	-	-	-	-	-	-	-	Sector Count	-	-	-	-	-	-	-	-
Sector Number	-	-	-	-	-	-	-	-	Sector Number	-	-	-	-	-	-	-	-
Cylinder Low	-	-	-	-	-	-	-	-	Cylinder Low	-	-	-	-	-	-	-	-
Cylinder High	-	-	-	-	-	-	-	-	Cylinder High	-	-	-	-	-	-	-	-
Device/Head	1	-	1	D	-	-	-	-	Device/Head	-	-	-	-	-	-	-	-
Command	1	1	1	1	0	0	1	0	Status	see below							

Error Register							
7	6	5	4	3	2	1	0
CRC	UNC	0	IDN	0	ABT	T0N	AMN
0	V	0	0	0	V	0	0

Status Register							
7	6	5	4	3	2	1	0
BSY	RDY	DF	DSC	DRQ	COR	IDX	ERR
0	V	0	-	-	0	-	V

Figure 113. Security Unlock command (F2h)

This command unlocks the password and causes the device to enter device unlock mode. If a power on reset or hard reset is done without executing the Security Disable Password command after this command is completed, the device will be in device lock mode. The password has not been changed yet.

The Security Unlock command requests to transfer a single sector of data from the host including information specified in Figure 114 on page 152.

If the Identifier bit is set to master and the drive is in high security mode then the password supplied will be compared with the stored master password. If the drive is in maximum security mode then the security unlock will be rejected.

If the Identifier bit is set to user, then the drive compares the supplied password with the stored user password.

If the password compare fails then the device returns an abort error to the host and decrements the unlock attempt counter. This counter is initially set to 5 and is decremented for each password mismatch. When this counter reaches zero, all password protected commands are rejected until there is a hard reset or a power off.

Word	Description
00	Control Word bit 0 : Identifier (1- Master, 0- User) bit 1-15 : Reserved
01-16	Password (32 bytes)
17-255	Reserved

Figure 114. Security Unlock information

Identifier A zero indicates that the device regards Password as the User Password. A one indicates that the device regards Password as the Master Password.

The user can detect if the attempt to unlock the device has failed due to a mismatched password since this is the only reason that an abort error will be returned by the drive AFTER the password information has been sent to the device. If an abort error is returned by the device BEFORE the password data has been sent to the drive, then another problem exists.

13.26 Seek (7xh)

Command Block Output Registers								Command Block Input Registers									
Register	7	6	5	4	3	2	1	0	Register	7	6	5	4	3	2	1	0
Data	-	-	-	-	-	-	-	-	Data	-	-	-	-	-	-	-	-
Feature	-	-	-	-	-	-	-	-	Error	see below							
Sector Count	-	-	-	-	-	-	-	-	Sector Count	-	-	-	-	-	-	-	-
Sector Number	V	V	V	V	V	V	V	V	Sector Number	V	V	V	V	V	V	V	V
Cylinder Low	V	V	V	V	V	V	V	V	Cylinder Low	V	V	V	V	V	V	V	V
Cylinder High	V	V	V	V	V	V	V	V	Cylinder High	V	V	V	V	V	V	V	V
Device/Head	1	L	1	D	H	H	H	H	Device/Head	-	-	-	-	H	H	H	H
Command	0	1	1	1	-	-	-	-	Status	see below							

Error Register							
7	6	5	4	3	2	1	0
CRC	UNC	0	IDN	0	ABT	T0N	AMN
0	0	0	V	0	V	0	0

Status Register							
7	6	5	4	3	2	1	0
BSY	RDY	DF	DSC	DRQ	COR	IDX	ERR
0	V	0	V	-	0	-	V

Figure 115. Seek command (7xh)

The Seek command initiates a seek to the designated track and selects the designated head. The device does not need to be formatted for a seek to execute properly.

Output parameters to the device

Sector Number In LBA mode this register specifies the LBA address bits 0–7 for seek. (L = 1)

Cylinder High/Low This is the cylinder number of the seek. In LBA mode this register specifies the LBA address bits 8–15 (Low) and bits 16–23 (High) for seek. (L = 1)

H This indicates the head number of the seek. In LBA mode this register specifies the LBA address bits 24–27 for seek. (L = 1)

Input parameters from the device

Sector Number In LBA mode this register contains the current LBA bits 0–7. (L = 1)

Cylinder High/Low In LBA mode this register contains the current LBA bits 8–15 (Low) and bits 16–23 (High). (L = 1)

H In LBA mode this register contains the current LBA bits 24–27. (L = 1)

13.27 Sense Condition (F0h: vendor specific)

Command Block Output Registers								Command Block Input Registers									
Register	7	6	5	4	3	2	1	0	Register	7	6	5	4	3	2	1	0
Data	-	-	-	-	-	-	-	-	Data	-	-	-	-	-	-	-	-
Feature	0	0	0	0	0	0	0	1	Error	see below							
Sector Count	-	-	-	-	-	-	-	-	Sector Count	V	V	V	V	V	V	V	V
Sector Number	-	-	-	-	-	-	-	-	Sector Number	-	-	-	-	-	-	-	N
Cylinder Low	-	-	-	-	-	-	-	-	Cylinder Low	-	-	-	-	-	-	-	-
Cylinder High	-	-	-	-	-	-	-	-	Cylinder High	-	-	-	-	-	-	-	-
Device/Head	1	-	1	D	-	-	-	-	Device/Head	-	-	-	D	-	-	-	-
Command	1	1	1	1	0	0	0	0	Status	see below							

Error Register							
7	6	5	4	3	2	1	0
CRC	UNC	0	IDN	0	ABT	T0N	AMN
0	0	0	V	0	V	0	0

Status Register							
7	6	5	4	3	2	1	0
BSY	RDY	DF	DSC	DRQ	COR	IDX	ERR
V	V	V	-	V	-	-	V

Figure 116. Sense Condition Command (F0h)

The Sense Condition command is used to sense temperature in a device. This command is executable without spinning up even if a device is started with No Spin Up option. If this command is issued at the temperature out of range which is specified for operating condition, the error might be returned with IDN bit 1.

Input parameters to the device

Feature The Feature register must be set to 01h. All other values are rejected with setting ABORT bit in status register.

Input parameters from the device

Sector Count The Sector Count register contains result value.

Value Description

00h Temperature is equal to or lower than -20°C
 01h-FEh Temperature is (Value/2-20)°C
 FFh Temperature is higher than 107°C

N Not recommendable condition for start up. If over stressed condition is detected, this bit will be set to one.

13.28 Set Features (EFh)

Command Block Output Registers								Command Block Input Registers									
Register	7	6	5	4	3	2	1	0	Register	7	6	5	4	3	2	1	0
Data	-	-	-	-	-	-	-	-	Data	-	-	-	-	-	-	-	-
Feature	V	V	V	V	V	V	V	V	Error	see below							
Sector Count	see note 1								Sector Count	-							
Sector Number	-								Sector Number	-							
Cylinder Low	-								Cylinder Low	-							
Cylinder High	-								Cylinder High	-							
Device/Head	1	-	1	D	-	-	-	-	Device/Head	-							
Command	1	1	1	0	1	1	1	1	Status	see below							

Error Register							
7	6	5	4	3	2	1	0
CRC	UNC	0	IDN	0	ABT	T0N	AMN
0	0	0	0	0	V	0	0

Status Register							
7	6	5	4	3	2	1	0
BSY	RDY	DF	DSC	DRQ	COR	IDX	ERR
0	V	0	-	-	0	-	V

Figure 117. Set Features command (EFh)

The Set Feature command establishes the following parameters which affect the execution of certain features as shown in the table below.

ABT will be set to 1 in the Error Register if the Feature register contains any undefined values.

After the power on reset or hard reset the device is set to the following features as default.

Write cache	Enable
ECC bytes	4 bytes
Read look-ahead	Enable
Reverting to power on defaults	Disable
Address Offset mode	Disable

Output parameters to the device

Feature	Destination code for this command.
02H	Enable write cache (See note 2)
03H	Set transfer mode based on value in sector count register
05H	Reserved (See note 3)
09H	Enable Address Offset mode
44H	40 bytes of ECC apply on Read Long/Write Long commands
55H	Disable read look-ahead feature
66H	Disable reverting to power on defaults
82H	Disable write cache
85H	Reserved (See note 3)
89H	Disable Address Offset mode
AAH	Enable read look-ahead feature
BBH	4 bytes of ECC apply on Read Long/Write Long commands
CCH	Enable reverting to power on defaults

Note 1. When the Feature register is 03h (= Set Transfer mode) the Sector Count Register specifies the transfer mechanism. The upper 5 bits define the type of transfer and the low order 3 bits encode the mode value.

PIO Default Transfer Mode	00000 000
PIO Default Transfer Mode,Disable IORDY	00000 001
PIO Flow Control Transfer Mode x 00001 nnn	00001 (nnn=000,001,010,011,100)
Multiword DMA mode x 00100 nnn	00100 nnn (nnn=000,001,010)
Ultra DMA mode x 01000 nnn	01000 nnn (nnn=000,001,010,011,100)

Note 2. If the number of auto reassigned sectors reaches the device's reassignment capacity, the write cache function will be automatically disabled. Although the device still accepts the Set Features command (with Feature register = 02h) without error, the write cache function will remain disabled. For the current write cache function status, refer to the Identify Device Information (129 word) by the Identify Device command.

Hard reset or power off must not be done during the first 5 seconds after write command completion when write cache is enabled.

Note 3. When the Feature register is 05h or 85h, device does not report command aborted but no feature of the device is changed.

13.29 Set Max ADDRESS (F9h)

Command Block Output Registers								Command Block Input Registers									
Register	7	6	5	4	3	2	1	0	Register	7	6	5	4	3	2	1	0
Data	-	-	-	-	-	-	-	-	Data	-	-	-	-	-	-	-	-
Feature	V	V	V	V	V	V	V	V	Error	see below							
Sector Count	-	-	-	-	-	-	-	B	Sector Count	-	-	-	-	-	-	-	-
Sector Number	V	V	V	V	V	V	V	V	Sector Number	V	V	V	V	V	V	V	V
Cylinder Low	V	V	V	V	V	V	V	V	Cylinder Low	V	V	V	V	V	V	V	V
Cylinder High	V	V	V	V	V	V	V	V	Cylinder High	V	V	V	V	V	V	V	V
Device/Head	1	L	1	D	H	H	H	H	Device/Head	-	-	-	-	H	H	H	H
Command	1	1	1	1	1	0	0	1	Status	see below							

Error Register							
7	6	5	4	3	2	1	0
CRC	UNC	0	IDN	0	ABT	T0N	AMN
0	0	0	0	0	V	0	0

Status Register							
7	6	5	4	3	2	1	0
BSY	RDY	DF	DSC	DRQ	COR	IDX	ERR
0	V	0	-	-	0	-	V

Figure 118. Set Max ADDRESS (F9h)

The Set Max ADDRESS command overwrites the max LBA/CYL of the drive in a range of actual device capacities. Once the device receives this command, all accesses beyond that LBA/CYL are rejected by setting the ABORT bit in the status register. Identify the device command and Identify the device DMA command returns the LBA/CYL which is set via this command as a default value.

This command implement SET MAX security extension commands as subcommands. But regardless of Feature register value, the case this command is immediately preceded by a Read Native Max ADDRESS command, it is interpreted as a Set Max ADDRESS command.

The Read Native Max ADDRESS command should be issued and completed immediately prior to issuing the Set Max ADDRESS command. If it is not, this command is interpreted as a Set Max security extension command which is designated by feature register.

If Set Max security mode is in the Locked or Frozen, the Set Max ADDRESS command is aborted. For more information, see section 11.9.2, "Set Max security extension commands" on page 89.

In CHS mode, Cylinder High, Cylinder Low specify the maximum cylinder number. The Head number of DEVICE/HEAD and Sector Number are ignored. The default value (see default CHS in Identify device information) is used for that.

In LBA mode, the Head number of DEVICE/HEAD , the Cylinder High, the Cylinder Low, and the Sector Number specify the max LBA. This command will set this LBA as the max LBA of the device.

Output parameters to the device

Feature Destination code for this command

01h SET MAX SET PASSWORD

02h SET MAX LOCK

03h SET MAX UNLOCK

04h SET MAX FREEZE LOCK

When the Set Max ADDRESS command is executed, this register is ignored.

B This indicates the option bit for selection whether nonvolatile or volatile. B = 0 is the volatile condition. When B = 1, MAX LBA/CYL—which is set by the Set Max ADDRESS command—is preserved by POR and HARD RESET. When B = 0, MAX LBA/CYL—which is set by Set Max ADDRESS command—will be lost by POR and HARD RESET. B = 1 is not valid when the device is in Address Offset mode and the command is aborted.

Sector Number In LBA mode this register contains LBA bits 0–7 which are to be input. (L = 1) In CHS mode this register is ignored. (L = 0)

Cylinder High/Low In LBA mode this register contains LBA bits 8–15 (Low) and bits 16–23 (High) which are to be set. (L = 1)

H In LBA mode this register contains LBA bits 24–27 which are to be input. (L = 1) In CHS mode this register is ignored. (L = 0)

L This indicates the LBA addressing mode. L = 0 specifies the CHS mode and L = 1 specifies the LBA addressing mode.

D This indicates the device number bit. The device number bit of the Device/Head should be specified. D = 0 selects the master device and D = 1 selects the slave device.

Input parameters from the device

Sector Number In LBA mode this register contains the Adjusted max. LBA bits 0–7. (L = 1) In CHS mode this register contains the maximum sector number (= 63). (L = 0)

Cylinder High/Low In LBA mode this register contains the Adjusted max. LBA bits 8–15 (Low) and bits 16–23 (High). (L = 1)
In CHS mode this register contains the max cylinder number which is set. (L = 0)

H In LBA mode this register contains the Adjusted max. LBA bits 24–27. (L = 1) In CHS mode this register contains the maximum head number (= 15). (L = 0)

13.30 Set Multiple (C6h)

Command Block Output Registers								Command Block Input Registers									
Register	7	6	5	4	3	2	1	0	Register	7	6	5	4	3	2	1	0
Data	-	-	-	-	-	-	-	-	Data	-	-	-	-	-	-	-	-
Feature	-	-	-	-	-	-	-	-	Error	see below							
Sector Count	V	V	V	V	V	V	V	V	Sector Count	-	-	-	-	-	-	-	-
Sector Number	-	-	-	-	-	-	-	-	Sector Number	-	-	-	-	-	-	-	-
Cylinder Low	-	-	-	-	-	-	-	-	Cylinder Low	-	-	-	-	-	-	-	-
Cylinder High	-	-	-	-	-	-	-	-	Cylinder High	-	-	-	-	-	-	-	-
Device/Head	1	-1	D	-	-	-	-	-	Device/Head	-	-	-	-	-	-	-	-
Command	1	1	0	0	0	1	1	0	Status	see below							

Error Register							
7	6	5	4	3	2	1	0
CRC	UNC	0	IDN	0	ABT	T0N	AMN
0	0	0	0	0	V	0	0

Status Register							
7	6	5	4	3	2	1	0
BSY	RDY	DF	DSC	DRQ	COR	IDX	ERR
0	V	0	-	-	0	-	V

Figure 119. Set Multiple command (C6h)

The Set Multiple command enables the device to perform Read and Write Multiple commands and establishes the block size for these commands. The block size is the number of sectors to be transferred for each interrupt.

The default block size after power up or hard reset is 0. The Read Multiple and Write Multiple commands are disabled.

If an invalid block size is specified, an Abort error will be returned to the host. The Read Multiple and Write Multiple commands will be disabled.

Output parameters to the device

Sector Count. This indicates the block size to be used for the Read Multiple and the Write Multiple commands. Valid block sizes can be selected from 0, 2, 4, 8 or 16. If 0 is specified, then the Read Multiple and the Write Multiple commands are disabled.

13.31 Sleep (E6h/99h)

Command Block Output Registers								Command Block Input Registers									
Register	7	6	5	4	3	2	1	0	Register	7	6	5	4	3	2	1	0
Data	-	-	-	-	-	-	-	-	Data	-	-	-	-	-	-	-	-
Feature	-	-	-	-	-	-	-	-	Error	see below							
Sector Count	-	-	-	-	-	-	-	-	Sector Count	-	-	-	-	-	-	-	-
Sector Number	-	-	-	-	-	-	-	-	Sector Number	-	-	-	-	-	-	-	-
Cylinder Low	-	-	-	-	-	-	-	-	Cylinder Low	-	-	-	-	-	-	-	-
Cylinder High	-	-	-	-	-	-	-	-	Cylinder High	-	-	-	-	-	-	-	-
Device/Head	1	-	1	D	-	-	-	-	Device/Head	-	-	-	-	-	-	-	-
Command	1	1	1	0	0	1	1	0	Status	see below							

Error Register							
7	6	5	4	3	2	1	0
CRC	UNC	0	IDN	0	ABT	T0N	AMN
0	0	0	0	0	V	0	0

Status Register							
7	6	5	4	3	2	1	0
BSY	RDY	DF	DSC	DRQ	COR	IDX	ERR
0	V	0	V	-	0	-	V

Figure 120. Sleep command (E6h/99h)

This command is the only way to cause the device to enter Sleep Mode.

When this command is issued, the device confirms the completion of the cached write commands before it asserts INTRQ. Then the device is spun down, and the interface becomes inactive. The only way to recover from Sleep Mode is with a software reset or a hardware reset.

The use of hardware reset to recover from Sleep Mode may be incompatible with continued operation of the host system.

If the device is already spun down, the spin down sequence is not executed.

13.32 S.M.A.R.T. Function Set (B0h)

Command Block Output Registers								Command Block Input Registers									
Register	7	6	5	4	3	2	1	0	Register	7	6	5	4	3	2	1	0
Data	-	-	-	-	-	-	-	-	Data	-	-	-	-	-	-	-	-
Feature	V	V	V	V	V	V	V	V	Error	see below							
Sector Count	V	V	V	V	V	V	V	V	Sector Count	-	-	-	-	-	-	-	-
Sector Number	-	-	-	-	-	-	-	-	Sector Number	-	-	-	-	-	-	-	-
Cylinder Low	0	1	0	0	1	1	1	1	Cylinder Low	-	-	-	-	-	-	-	-
Cylinder High	1	1	0	0	0	0	1	0	Cylinder High	-	-	-	-	-	-	-	-
Device/Head	1	-	1	D	-	-	-	-	Device/Head	-	-	-	-	-	-	-	-
Command	1	0	1	1	0	0	0	0	Status	see below							

Error Register							
7	6	5	4	3	2	1	0
CRC	UNC	0	IDN	0	ABT	T0N	AMN
0	0	0	0	0	V	0	0

Status Register							
7	6	5	4	3	2	1	0
BSY	RDY	DF	DSC	DRQ	COR	IDX	ERR
0	V	0	V	-	0	-	V

Figure 121. S.M.A.R.T. Function Set command (B0h)

The S.M.A.R.T. Function Set command provides access to the Attribute Values, the Attribute Thresholds, and other low level subcommands that can be used for logging and reporting purposes and to accommodate special user needs. The S.M.A.R.T. Function Set command has several separate subcommands which are selectable via the device's Features Register when the S.M.A.R.T. Function Set command is issued by the host.

In order to select a subcommand the host must write the subcommand code to the device's Features Register before issuing the S.M.A.R.T. Function Set command. The subcommands and their respective codes are listed below.

Code	Subcommand
D0h	S.M.A.R.T. Read Attribute Values
D1h	S.M.A.R.T. Read Attribute Thresholds
D2h	S.M.A.R.T. Enable/disable Attribute Autosave
D3h	S.M.A.R.T. Save Attribute Values
D4h	S.M.A.R.T. Execute Off-line Immediate
D5h	S.M.A.R.T. Read Log Sector
D6h	S.M.A.R.T. Write Log Sector
D8h	S.M.A.R.T. Enable Operations
D9h	S.M.A.R.T. Disable Operations
DAh	S.M.A.R.T. Return Status
DBh	S.M.A.R.T. Enable/Disable Automatic Off-line

13.32.1 S.M.A.R.T. Function Subcommands

13.32.1.1 S.M.A.R.T. Read Attribute Values (subcommand D0h)

This subcommand returns the device's Attribute Values to the host. Upon receipt of the S.M.A.R.T. Read Attribute Values subcommand from the host, the device asserts BSY, saves any updated Attribute Values to the Attribute Data sectors, asserts DRQ, clears BSY, asserts INTRQ, and then waits for the host to transfer the 512 bytes of Attribute Value information from the device via the Data Register.

13.32.1.2 S.M.A.R.T. Read Attribute Thresholds (subcommand D1h)

This subcommand returns the device's Attribute Thresholds to the host. Upon receipt of the S.M.A.R.T. Read Attribute Thresholds subcommand from the host, the device asserts BSY, reads the Attribute Thresholds from the Attribute Threshold sectors, asserts DRQ, clears BSY, asserts INTRQ, and then waits for the host to transfer the 512 bytes of Attribute Thresholds information from the device via the Data Register.

13.32.1.3 S.M.A.R.T. Enable/Disable Attribute Autosave (subcommand D2h)

This subcommand enables and disables the attribute auto save feature of the device. The S.M.A.R.T. Enable/Disable Attribute Autosave subcommand allows the device to automatically save its updated Attribute Values to the Attribute Data Sector at the timing of the first transition to Active idle mode and after 30 minutes after the last saving of Attribute Values. This subcommand causes the auto save feature to be disabled. The state of the Attribute Autosave feature—either enabled or disabled—will be preserved by the device across the power cycle.

A value of 00h—written by the host into the device's Sector Count Register before issuing the S.M.A.R.T. Enable/Disable Attribute Autosave subcommand—will cause this feature to be disabled. Disabling this feature does not preclude the device from saving Attribute Values to the Attribute Data sectors during some other normal operation such as during a power-up or a power-down.

A value of F1h—written by the host into the device's Sector Count Register before issuing the S.M.A.R.T. Enable/Disable Attribute Autosave subcommand—will cause this feature to be enabled. Any other nonzero value written by the host into this register before issuing the S.M.A.R.T. Enable/Disable Attribute Autosave subcommand will not change the current Autosave status. The device will respond with the error code specified in Figure 133 on page 177.

The S.M.A.R.T. Disable Operations subcommand disables the auto save feature along with the device's S.M.A.R.T. operations.

Upon the receipt of the subcommand from the host, the device asserts BSY, enables or disables the Autosave feature, clears BSY, and asserts INTRQ.

13.32.1.4 S.M.A.R.T. Save Attribute Values (subcommand D3h)

This subcommand causes the device to immediately save any updated Attribute Values to the device's Attribute Data sector regardless of the state of the Attribute Autosave feature. Upon receipt of the S.M.A.R.T. Save Attribute Values subcommand from the host, the device asserts BSY, writes any updated Attribute Values to the Attribute Data sector, clears BSY, and asserts INTRQ.

13.32.1.5 S.M.A.R.T. Execute Off-line Immediate (subcommand D4h)

This subcommand causes the device to immediately initiate the set of activities that collect Attribute data in an off-line mode (off-line routine) or execute a self-test routine in either captive or off-line mode. The Sector Number register shall be set to specify the operation to be executed.

Sector Number	Operation to be executed
0	Execute S.M.A.R.T. off-line data collection routine immediately
1	Execute S.M.A.R.T. Short self-test routine immediately in off-line mode
2	Execute S.M.A.R.T. Extended self-test routine immediately in off-line mode
127	Abort off-line mode self-test routine
129	Execute S.M.A.R.T. Short self-test routine immediately in captive mode
130	Execute S.M.A.R.T. Extended self-test routine immediately in captive mode

Off-line mode: The device executes command completion before executing the specified routine. During execution of the routine the device will not set BSY nor clear DRDY. If the device is in the process of performing its routine and is interrupted by a new command from the host, the device will abort or suspend its routine and service the host within two seconds after receipt of the new command. After servicing the interrupting command, the device will resume its routine automatically or not start its routine depending on the interrupting command.

Captive mode: When executing self-test in captive mode, the device sets BSY to one and executes the specified self-test routine after receipt of the command. At the end of the routine, the device sets the execution result in the Self-test execution status byte (Figure 123 on page 166) and ATA registers—see definitions below—and then executes the command completion.

Status	Set ERR to one when the self-test has failed
Error	Set ABRT to one when the self-test has failed
Cyl Low	Set to F4h when the self-test has failed
Cyl High	Set to 2Ch when the self-test has failed

13.32.1.6 S.M.A.R.T. Read Log Sector (subcommand D5h)

This command returns the specified log sector contents to the host.

The 512 bytes of data are returned at a command and the Sector Count value shall be set to one. The Sector Number shall be set to specify the log sector address.

Log sector address	Content	Type
01h	S.M.A.R.T. Error Log	Read Only
06h	S.M.A.R.T. Self-test Log	Read Only
80h-9Fh	Host vendor specific	Read/Write

Figure 122. Log sector addresses

13.32.1.7 S.M.A.R.T. Write Log Sector (subcommand D6h)

This command writes 512 bytes of data to the specified log sector.

The 512 bytes of data are transferred at a command and the Sector Count value shall be set to one. The Sector Number shall be set to specify the log sector address (Figure 122). If a Read Only log sector is specified, the device returns ABRT error.

13.32.1.8 S.M.A.R.T. Enable Operations (subcommand D8h)

This subcommand enables access to all S.M.A.R.T. capabilities within the device. Prior to receipt of a S.M.A.R.T. Enable Operations subcommand, Attribute Values are neither monitored nor saved by the device. The state of S.M.A.R.T.—either enabled or disabled—will be preserved by the device across power cycles. Once enabled, the receipt of subsequent S.M.A.R.T. Enable Operations subcommands will not affect any of the Attribute Values.

Upon receipt of the S.M.A.R.T. Enable Operations subcommand from the host, the device asserts BSY, enables S.M.A.R.T. capabilities and functions, clears BSY, and asserts INTRQ.

13.32.1.9 S.M.A.R.T. Disable Operations (subcommand D9h)

This subcommand disables all S.M.A.R.T. capabilities within the device including the device's attribute auto save feature. After receipt of this subcommand the device disables all S.M.A.R.T. operations. Non self-preserved Attribute Values will no longer be monitored. The state of S.M.A.R.T.—either enabled or disabled—is preserved by the device across power cycles. Note that this subcommand does not preclude the device's power mode attribute auto saving.

Upon receipt of the S.M.A.R.T. Disable Operations subcommand from the host, the device asserts BSY, disables S.M.A.R.T. capabilities and functions, clears BSY, and asserts INTRQ.

After receipt of the device of the S.M.A.R.T. Disable Operations subcommand from the host, all other S.M.A.R.T. subcommands—with the exception of S.M.A.R.T. Enable Operations—are disabled, and invalid and will be aborted by the device—including the S.M.A.R.T. Disable Operations subcommand—returning the error code as specified in Figure 133 on page 177.

Any Attribute Values accumulated and saved to volatile memory prior to receipt of the S.M.A.R.T. Disable Operations command will be preserved in the device's Attribute Data Sectors. If the device is re-enabled, these Attribute Values will be updated, as needed, upon receipt of a S.M.A.R.T. Read Attribute Values or a S.M.A.R.T. Save Attribute Values command.

13.32.1.10 S.M.A.R.T. Return Status (subcommand DAh)

This subcommand is used to communicate the reliability status of the device to the host's request. Upon receipt of the S.M.A.R.T. Return Status subcommand the device asserts BSY, saves any updated Attribute Values to the reserved sector, and compares the updated Attribute Values to the Attribute Thresholds.

If the device does not detect a Threshold Exceeded Condition, or detects a Threshold Exceeded Condition but involving attributes are advisory, the device loads 4Fh into the Cylinder Low register, C2h into the Cylinder High register, clears BSY, and asserts INTRQ.

If the device detects a Threshold Exceeded Condition for prefailure attributes, the device loads F4h into the Cylinder Low register, 2Ch into the Cylinder High register, clears BSY, and asserts INTRQ. Advisory attributes never result in a negative reliability condition.

13.32.1.11 S.M.A.R.T. Enable/Disable Automatic Off-line (subcommand DBh)

This subcommand enables and disables the optional feature that cause the device to perform the set of off-line data collection activities that automatically collect attribute data in an off-line mode and then save this data to the device's nonvolatile memory. This subcommand may either cause the device to automatically initiate or resume performance of its off-line data collection activities or cause the automatic off-line data collection feature to be disabled. This subcommand also enables and disables the off-line read scanning feature that cause the device to perform the entire read scanning with defect reallocation as the part of the off-line data collection activities.

The Sector Count register shall be set to specify the feature to be enabled or disabled:

Sector Count	Feature Description
00h	Disable Automatic Off-line
01h	Disable Off-line Read Scanning
F8h	Enable Automatic Off-line
F9h	Enable Off-line Read Scanning

A value of zero written by the host into the device's Sector Count register before issuing this subcommand shall cause the automatic off-line data collection feature to be disabled. Disabling this feature does not preclude the device from saving attribute values to nonvolatile memory during some other normal operation such as during a power-on, during a power-off sequence, or during an error recovery sequence.

A value of one written by the host into the device's Sector Count register before issuing this subcommand shall cause the off-line read scanning feature to be disabled. The Device does not perform the off-line read scanning at the off-line data collection activities which is initiated by the S.M.A.R.T. Execute Off-line Immediate (Subcommand D4h) or automatically if the off-line read scanning feature is disabled.

A value of F8h written by the host into the device's Sector Count register before issuing this subcommand shall cause the automatic Off-line data collection feature to be enabled.

A value of F9 written by the host into the device's Sector Count register before issuing this subcommand shall cause the off-line read scanning feature to be enabled. The Device perform the off-line read scanning at the off-line data collection activities which is initiated by the S.M.A.R.T. Execute Off-line Immediate (Subcommand D4h) even if the automatic off-line feature is disabled.

Any other nonzero value written by the host into this register before issuing this subcommand is vendor specific and will not change the current Automatic Off-Line Data Collection and Off-line Read Scanning status. However, the device may respond with the error code specified in Figure 133 on page 177.

13.32.2 Device Attributes Data Structure

The following defines the 512 bytes that make up the Attribute Value information. This data structure is accessed by the host in its entirety using the S.M.A.R.T. Read Attribute Values subcommand. All multibyte fields shown in these data structures follow the ATA/ATAPI-5 specification for byte ordering, namely, that the least significant byte occupies the lowest numbered byte address location in the field.

Description	Byte	Offset	Format	Value
Data Structure Revision Number	2	00h	binary	0010h
1st Device Attribute	12	02h	(*1)	(*2)
↑	↑	↑	↑	↑
30th Device Attribute	12	15Eh	(*1)	(*2)
Off-line data collection status	1	16Ah	(*1)	(*2)
Self-test execution status	1	16Bh	(*1)	(*2)
Total time in seconds to complete off-line data collection activity	2	16Ch	(*1)	(*2)
Current segment pointer	1	16Eh	(*1)	(*2)
Off-line data collection capability	1	16Fh	(*1)	1Bh
S.M.A.R.T. capability	2	170h	(*1)	0003h
S.M.A.R.T. device error logging capability	1	172h	(*1)	01h
Self-test failure check point	1	173h	(*1)	(*2)
Short self-test completion time in minutes	1	174h	(*1)	(*2)
Extended self-test completion time in minutes	1	175h	(*1)	(*2)
Reserved	12	176h		(*3)
Vendor specific	125	182h		(*3)
Data structure checksum	1	1FFh	(*1)	(*2)
	512			

(*1) – See following definitions

(*2) – This value varies due to actual operating condition.

(*3) – Filled with 00h.

Figure 123. Device Attribute Data Structure

13.32.2.1 Data Structure Revision Number

The Data Structure Revision Number identifies which version of this data structure is implemented by the device. This revision number will be set to 0005h. This revision number identifies both the Attribute Value and Attribute Threshold Data structures.

13.32.2.2 Individual Attribute Data Structure

The following defines the 12 bytes that make up the information for each Attribute entry in the Device Attribute Data Structure.

Description	Byte	Offset	Value
Attribute ID Number (01h to FFh)	1	00h	binary
Status Flags	2	01h	bit flags
Bit 0 Pre-Failure/Advisory			
Bit 1 On-line Collection			
Bit 2-5 Reserved (may be either 0 or 1)			
Bit 6-15 Reserved (all 0)			
Attribute Value (valid values from 01h to FEh)	1	03h	binary
00h invalid for attribute value -not to be used			
01h minimum value			
64h initial value for all attributes prior to any data collection			
FDh maximum value			
FEh value is not valid			
FFh invalid for attribute value-not to be used			
Reserved (may not be 0)	1	04h	binary
Reserved (may not be 0)	6	05h	binary
Reserved (00h)	1	0Bh	binary
Total Bytes	12		

Figure 124. Individual Attribute Data Structure

Attribute ID Numbers: Any nonzero value in the Attribute ID Number indicates an active attribute. The device supports following Attribute ID Numbers. The names marked with (*) indicate that the corresponding Attribute Values can be either collected on-line or off-line.

ID	Attribute Name
0	Indicates that this entry in the data structure is not used
1	Raw Read Error Rate (*)
2	Throughput Performance (*)
3	Spin Up Time
4	Start/Stop Count
5	Reallocated Sector Count
7	Seek Error Rate
8	Seek Time Performance (*)
9	Power-On Hours Count
10	Spin Retry Count
12	Device Power Cycle Count
191	Gsense Error Rate
192	Power Off Retract Count
193	Load/Unload Cycle Count
194	Device Temperature
196	Reallocation Event Count

- 197** Current Pending Sector Count
- 198** Off-Line Scan Uncorrectable Sector Count
- 199** Ultra DMA CRC Error Count

Status Flag definitions:

Bit	Flag Name	Definition
0	Pre-Failure/ Advisory bit	If bit = 0, an Attribute Value less than or equal to its corresponding Attribute Threshold indicates an Advisory condition where the usage or age of the device has exceeded its intended design life period. If bit = 1, an Attribute Value less than or equal to its corresponding Attribute Threshold indicates a Pre-Failure condition where imminent loss of data is being predicted.
1	On-Line Collective bit	If bit = 0, the Attribute Value is updated only during Off-Line testing. If bit = 1, the Attribute Value is updated during On-Line testing or during both On-Line and Off-Line testing.
2-5	Reserved bits	May either be 0 or 1
6-15	Reserved bits	Always 0

Figure 125. Status Flag definitions

Normalized values: The device will perform conversion of the raw Attribute Values to transform them into normalized values which the host can then compare with the Threshold values. A Threshold is the excursion limit for a normalized Attribute Value. In normalizing the raw data, the device will perform any necessary statistical validity checks to ensure that an instantaneous raw value is not improperly reflected in the normalized Attribute Value (i.e., one read error in the first 10 reads being interpreted as exceeding the read error rate threshold when the subsequent 1 billion reads all execute without error). The end points for the normalized values for all Attributes will be 1 (01h) at the low end and 100 (64h) at the high end for the device. For Performance and Error Rate Attributes, values greater than 100 are also possible. The maximum value possible is 253 (FDh).

13.32.2.3 Off-Line Data Collection Status

The value of this byte defines the current status of the off-line activities of the device. Bit 7 indicates an Automatic Off-line Data Collection Status.

- Bit 7 Automatic Off-line Data Collection Status**
- 0** Automatic Off-line Data Collection is disabled.
 - 1** Automatic Off-line Data Collection is enabled.

Bits 0–6 represent a hexadecimal status value reported by the device.

- | Value | Definition |
|--------------|---|
| 0 | Off-line data collection never started. |

- 2 All segments completed without errors. In this case the current segment pointer is equal to the total segments required.
- 4 Off-line data collection is suspended by the interrupting command.
- 5 Off-line data collecting is aborted by the interrupting command.
- 6 Off-line data collection is aborted with a fatal error.

13.32.2.4 Self-test execution status

Bit Definition

- 0-3 Percent Self-test remaining. An approximation of the percent of the self-test routine remaining until completion given in ten percent increments. Valid values are 0 through 9.
- 4-7 Current Self-test execution status.
 - 0 The self-test routine completed without error or has never been run.
 - 1 The self-test routine was aborted by the host.
 - 2 The self-test routine was interrupted by the host with a hard or soft reset.
 - 3 The device was unable to complete the self-test routine due to a fatal error or unknown test error.
 - 4 The self-test routine was completed with an unknown element failure.
 - 5 The self-test routine was completed with an electrical element failure.
 - 6 The self-test routine was completed with a servo element failure.
 - 7 The self-test routine was completed with a read element failure.
 - 15 The self-test routine is in progress.

13.32.2.5 Total time in seconds to complete off-line data collection activity

This field tells the host how many seconds the device requires to complete the off-line data collection activity.

13.32.2.6 Current segment pointer

This byte is a counter indicating the next segment to execute as an off-line data collection activity. Because the number of segments is 1, 01h is always returned in this field.

13.32.2.7 Off-line data collection capability

Bit Definition

- 0 Execute Off-line Immediate implemented bit
 - 0 S.M.A.R.T. Execute Off-line Immediate subcommand is not implemented
 - 1 S.M.A.R.T. Execute Off-line Immediate subcommand is implemented
- 1 Enable/disable Automatic Off-line implemented bit
 - 0 S.M.A.R.T. Enable/disable Automatic Off-line subcommand is not implemented
 - 1 S.M.A.R.T. Enable/disable Automatic Off-line subcommand is implemented

- 2 Abort/restart off-line by host bit
 - 0 The device will suspend off-line data collection activity after an interrupting command and resume it after a vendor specific event
 - 1 The device will abort off-line data collection activity upon receipt of a new command
- 3 Off-line Read Scanning implemented bit
 - 0 The device does not support Off-line Read Scanning
 - 1 The device supports Off-line Read Scanning
- 4 Self-test implemented bit
 - 0 Self-test routine is not implemented
 - 1 Self-test routine is implemented
- 5-7 Reserved (0)

13.32.2.8 S.M.A.R.T. Capability

This word of bit flags describes the S.M.A.R.T. capabilities of the device. The device will return 03h indicating that the device will save its Attribute Values prior to going into a power saving mode and supports the S.M.A.R.T. ENABLE/DISABLE ATTRIBUTE AUTOSAVE command.

Bit Definition

- 0 Pre-power mode attribute saving capability. If bit = 1, the device will save its Attribute Values prior to going into a power saving mode (Standby or Sleep mode).
- 1 Attribute auto save capability. If bit = 1, the device supports the S.M.A.R.T. ENABLE/DISABLE ATTRIBUTE AUTOSAVE command.
- 2-15 Reserved (0)

13.32.2.9 Error logging capability

Bit Definition

- 7-1 Reserved (0)
- 0 The Error Logging support bit. If bit = 1, the device supports the Error Logging

13.32.2.10 Self-test failure check point

This byte indicates the section of self-test where the device detected a failure.

13.32.2.11 Self-test completion time

These bytes are the minimum time in minutes to complete the self-test.

13.32.2.12 Data Structure Checksum

The Data Structure Checksum is the 2's compliment of the result of a simple 8-bit addition of the first 511 bytes in the data structure.

13.32.3 Device Attribute Thresholds data structure

The following defines the 512 bytes that make up the Attribute Threshold information. This data structure is accessed by the host in its entirety using the S.M.A.R.T. Read Attribute Thresholds. All multibyte fields shown in these data structures follow the ATA/ATAPI-5 specification for byte ordering, that is, that the least significant byte occupies the lowest numbered byte address location in the field.

The sequence of active Attribute Thresholds will appear in the same order as their corresponding Attribute Values.

Description	Byte	Offset	Format	Value
Data Structure Revision Number	2	00h	binary	0010h
1st Device Attribute	12	02h	(*1)	(*2)
...	..			
...	..			
30th Device Attribute	12	15Eh	(*1)	(*2)
Reserved	18	16Ah		(*3)
Vendor specific	131	17Ch		(*3)
Data structure checksum	1	1FFh		(*2)
	512			

(*1) - See the following definitions

(*2) - Value varies by actual operating condition

(*3) - Filled with 00h

Figure 126. Device Attribute Thresholds Data Structure

13.32.3.1 Data Structure Revision Number

This value is the same as the value used in the Device Attributes Values Data Structure.

13.32.3.2 Individual Thresholds Data Structure

The following defines the 12 bytes that make up the information for each Threshold entry in the Device Attribute Thresholds Data Structure. Attribute entries in the Individual Threshold Data Structure are in the same order and correspond to the entries in the Individual Attribute Data Structure.

Description	Byte	Offset	Format
Attribute ID Number (01h to FFh)	1	00h	binary
Attribute Threshold (for comparison with Attribute Values from 00h to FFh)	1	01h	binary
00h - "always passing" threshold value to be used for code test purposes			
01h - minimum value for normal operation			
FDh - maximum value for normal operation			
FEh - invalid for threshold value			
FFh - "always failing" threshold value to be used for code test purposes			
Reserved (00h)	10	02h	binary
Total Bytes	12		

Figure 127. Individual Threshold Data Structure

13.32.3.3 Attribute ID Numbers

Attribute ID Numbers supported by the device are the same as Attribute Values Data Structures.

13.32.3.4 Attribute Threshold

These values are preset at the factory and are not meant to be changeable. However, the host might use the "S.M.A.R.T. Write Attribute Threshold" subcommand to override these preset values in the Threshold sectors.

13.32.3.5 Data Structure Checksum

The Data Structure Checksum is the 2's compliment of the result of a simple 8-bit addition of the first 511 bytes in the data structure.

13.32.4 S.M.A.R.T. error log sector

The following defines the 512 bytes that make up the S.M.A.R.T. error log sector. All multibyte fields shown in these data structures follow the ATA/ATAPI-5 specifications for byte ordering.

Description	Byte	Offset
S.M.A.R.T. error log version	1	00h
Error log pointer	1	01h
1st error log data structure	90	02h
2nd error log data structure	90	5Ch
3rd error log data structure	90	B6h
4th error log data structure	90	110h
5th error log data structure	90	16Ah
Device error count	2	1C4h
Reserved	57	1C6h
Data structure checksum	1	1FFh
	512	

Figure 128. S.M.A.R.T. error log sector

13.32.4.1 S.M.A.R.T. error log version

This value is set to 01h.

13.32.4.2 Error log pointer

This points to the most recent error log data structure. Only values 1 through 5 are valid.

13.32.4.3 Device error count

This field contains the total number of errors. The value will not roll over.

13.32.4.4 Error log data structure

The data format of each error log structure is shown below.

Description	Byte	Offset
1st command data structure	12	00h
2nd command data structure	12	0Ch
3rd command data structure	12	18h
4th command data structure	12	24h
5th command data structure	12	30h
Error data structure	30	3Ch
	90	

Figure 129. Error log data structure

Command data structure: Data format of each command data structure is shown below.

Description	Byte	Offset
Device Control register	1	00h
Features register	1	01h
Sector count register	1	02h
Sector number register	1	03h
Cylinder Low register	1	04h
Cylinder High register	1	05h
Device/Head register	1	06h
Command register	1	07h
Time stamp (milliseconds from Power On)	4	08h
	12	

Figure 130. Command data structure

13.32.4.5 Error data structure

Data format of error data structure is shown below.

Description	Byte	Offset
Reserved	1	00h
Error register	1	01h
Sector count register	1	02h
Sector number register	1	03h
Cylinder Low register	1	04h
Cylinder High register	1	05h
Device/Head register	1	06h
Status register	1	07h
Extended error data (vendor specific)	19	08h
State	1	1Bh
Life time stamp (hours)	2	1Ch
	30	

Figure 131. Error data structure

State field contains a value indicating the device state when command was issued to the device.

Value	State
x0h	Unknown
x1h	Sleep
x2h	Standby
x3h	Active/Idle
x4h	S.M.A.R.T. Off-line or Self-test
x5h–xAh	Reserved
xBh–xFh	Vendor specific

Note: The value of the x is vendor specific.

13.32.5 Self-test log data structure

The following defines the 512 bytes that make up the Self-test log sector. All multibyte fields shown in these data structures follow the ATA/ATAPI-5 specifications for byte ordering.

Description	Byte	Offset
Data structure revision	2	00h
Self-test number	1	n*18h+02h
Self-test execution status	1	n*18h+03h
Life time power on hours	2	n*18h+04h
Self-test failure check point	1	n*18h+06h
LBA of first failure	4	n*18h+07h
Vendor specific	15	n*18h+08h
...		
Vendor specific	2	1FAh
Self-test log pointer	1	1FCh
Reserved	2	1FDh
Data structure checksum	1	1FFh
	512	

Note: N is 0 through 20

Figure 132. Self-test log data structure

The data structure contains the descriptor of the Self-test that the device has performed. Each descriptor is 24 bytes long and the self-test data structure is capable to contain up to 21 descriptors.

After 21 descriptors has been recorded, the oldest descriptor will be overwritten with the new descriptor.

The self-test log pointer points to the most recent descriptor. When there is no descriptor, the value is 0. When there are descriptor(s), the value is 1 through 21.

13.32.6 Error reporting

The following table shows the values returned in the Status and Error Registers when specific error conditions are encountered by a device.

Error condition	Status Register	Error Register
A S.M.A.R.T. FUNCTION SET command was received by the device without the required key being loaded into the Cylinder High and Cylinder Low registers.	51h	04h
A S.M.A.R.T. FUNCTION SET command was received by the device with a subcommand value in the Features Register that is either invalid or not supported by this device.	51h	04h
A S.M.A.R.T. FUNCTION SET command subcommand other than S.M.A.R.T. ENABLE OPERATIONS was received by the device while the device was in a "S.M.A.R.T. Disabled" state.	51h	04h
The device is unable to read its Attribute Values or Attribute Thresholds data structure	51h	10h or 40h
The device is unable to write to its Attribute Values data structure.	51h	10h or 01h

Figure 133. S.M.A.R.T. Error Codes

13.33 Standby (E2h/96h)

Command Block Output Registers								Command Block Input Registers									
Register	7	6	5	4	3	2	1	0	Register	7	6	5	4	3	2	1	0
Data	-	-	-	-	-	-	-	-	Data	-	-	-	-	-	-	-	-
Feature	-	-	-	-	-	-	-	-	Error	see below							
Sector Count	V	V	V	V	V	V	V	V	Sector Count	-	-	-	-	-	-	-	-
Sector Number	-	-	-	-	-	-	-	-	Sector Number	-	-	-	-	-	-	-	-
Cylinder Low	-	-	-	-	-	-	-	-	Cylinder Low	-	-	-	-	-	-	-	-
Cylinder High	-	-	-	-	-	-	-	-	Cylinder High	-	-	-	-	-	-	-	-
Device/Head	1	-	1	D	-	-	-	-	Device/Head	-	-	-	-	-	-	-	-
Command	1	1	1	0	0	0	1	0	Status	see below							

Error Register							
7	6	5	4	3	2	1	0
CRC	UNC	0	IDN	0	ABT	T0N	AMN
0	0	0	0	0	V	0	0

Status Register							
7	6	5	4	3	2	1	0
BSY	RDY	DF	DSC	DRQ	COR	IDX	ERR
0	V	0	V	-	0	-	V

Figure 134. Standby command (E2h/96h)

The Standby command causes the device to enter the Standby Mode immediately and to set the auto power down time-out parameter (standby timer).

When this command is issued, the device confirms the completion of the cached write commands before it asserts the INTRQ. Following the INTRQ the interface remains active and the device is spun down. If the device is already spun down, the spin down sequence is not executed.

During the Standby mode the device will respond to commands, however there will be a delay while waiting for the spindle to reach operating speed.

The timer starts counting down when the device returns to Idle mode.

Output parameters to the device

Sector Count

The Time-out Parameter. If it is zero, the time-out interval (Standby Timer) is NOT disabled but is automatically set to 109 minutes. If it is other than zero the time-out interval is set for (Time-out Parameter × 5) seconds.

When the automatic power down sequence is enabled, the device will enter the Standby mode automatically if the time-out interval expires with no device access from the host. The time-out interval will be reinitialized if there is a device access before the time-out interval expires.

13.34 Standby Immediate (E0h/94h)

Command Block Output Registers								Command Block Input Registers									
Register	7	6	5	4	3	2	1	0	Register	7	6	5	4	3	2	1	0
Data	-	-	-	-	-	-	-	-	Data	-	-	-	-	-	-	-	-
Feature	-	-	-	-	-	-	-	-	Error	see below							
Sector Count	-	-	-	-	-	-	-	-	Sector Count	-	-	-	-	-	-	-	-
Sector Number	-	-	-	-	-	-	-	-	Sector Number	-	-	-	-	-	-	-	-
Cylinder Low	-	-	-	-	-	-	-	-	Cylinder Low	-	-	-	-	-	-	-	-
Cylinder High	-	-	-	-	-	-	-	-	Cylinder High	-	-	-	-	-	-	-	-
Device/Head	1	-	1	D	-	-	-	-	Device/Head	-	-	-	-	-	-	-	-
Command	1	1	1	0	0	0	0	0	Status	see below							

Error Register							
7	6	5	4	3	2	1	0
CRC	UNC	0	IDN	0	ABT	T0N	AMN
0	0	0	0	0	V	0	0

Status Register							
7	6	5	4	3	2	1	0
BSY	RDY	DF	DSC	DRQ	COR	IDX	ERR
0	V	0	V	-	0	-	V

Figure 135. Standby Immediate command (E0h/94h)

The Standby Immediate command causes the device to enter the Standby mode immediately.

When this command is issued, the device confirms the completion of the cached write commands before it asserts the INTRQ. Following the INTRQ the interface remains active and the device is spun down. If the device is already spun down, the spin down sequence is not executed.

During the Standby mode the device will respond to commands, however there will be a delay while waiting for the spindle to reach operating speed.

The Standby Immediate command will not affect the auto power down time-out parameter.

13.35 Write Buffer (E8h)

Command Block Output Registers								Command Block Input Registers									
Register	7	6	5	4	3	2	1	0	Register	7	6	5	4	3	2	1	0
Data	-	-	-	-	-	-	-	-	Data	-	-	-	-	-	-	-	-
Feature	-	-	-	-	-	-	-	-	Error	see below							
Sector Count	-	-	-	-	-	-	-	-	Sector Count	-	-	-	-	-	-	-	-
Sector Number	-	-	-	-	-	-	-	-	Sector Number	-	-	-	-	-	-	-	-
Cylinder Low	-	-	-	-	-	-	-	-	Cylinder Low	-	-	-	-	-	-	-	-
Cylinder High	-	-	-	-	-	-	-	-	Cylinder High	-	-	-	-	-	-	-	-
Device/Head	1	-	1	D	-	-	-	-	Device/Head	-	-	-	-	-	-	-	-
Command	1	1	1	0	1	0	0	0	Status	see below							

Error Register							
7	6	5	4	3	2	1	0
CRC	UNC	0	IDN	0	ABT	T0N	AMN
0	0	0	0	0	V	0	0

Status Register							
7	6	5	4	3	2	1	0
BSY	RDY	DF	DSC	DRQ	COR	IDX	ERR
0	V	0	-	-	0	-	V

Figure 136. Write Buffer command (E8h)

The Write Buffer command transfers a sector of data from the host to the sector buffer of the device. The sectors of data are transferred through the Data Register 16 bits at a time.

The Read Buffer and Write Buffer commands are synchronized such that sequential Write Buffer and Read Buffer commands access the same 512 byte within the buffer.

13.36 Write DMA (CAh/CBh)

Command Block Output Registers								Command Block Input Registers									
Register	7	6	5	4	3	2	1	0	Register	7	6	5	4	3	2	1	0
Data	-	-	-	-	-	-	-	-	Data	-	-	-	-	-	-	-	-
Feature	-	-	-	-	-	-	-	-	Error	see below							
Sector Count	V	V	V	V	V	V	V	V	Sector Count	V	V	V	V	V	V	V	V
Sector Number	V	V	V	V	V	V	V	V	Sector Number	V	V	V	V	V	V	V	V
Cylinder Low	V	V	V	V	V	V	V	V	Cylinder Low	V	V	V	V	V	V	V	V
Cylinder High	V	V	V	V	V	V	V	V	Cylinder High	V	V	V	V	V	V	V	V
Device/Head	1	L	1	D	H	H	H	H	Device/Head	-	-	-	-	H	H	H	H
Command	1	1	0	0	1	0	1	R	Status	see below							

Error Register							
7	6	5	4	3	2	1	0
CRC	UNC	0	IDN	0	ABT	T0N	AMN
V	0	0	V	0	V	0	0

Status Register							
7	6	5	4	3	2	1	0
BSY	RDY	DF	DSC	DRQ	COR	IDX	ERR
0	V	V	V	-	0	-	V

Figure 137. Write DMA command (CAh/CBh)

The Write DMA command transfers one or more sectors of data from the host to the device and then the data is written to the disk media.

The sectors of data are transferred through the Data Register 16 bits at a time.

The host initializes a slave-DMA channel prior to issuing the command. Data transfers are qualified by DMARQ and are performed by the slave-DMA channel. The device issues only one interrupt per command to indicate that data transfer has terminated and status is available.

If an uncorrectable error occurs, the write will be terminated at the failing sector.

Output parameters to the device

Sector Count This indicates the number of continuous sectors to be transferred. If zero is specified, then 256 sectors will be transferred.

Sector Number This indicates the sector number of the first sector to be transferred. (L = 0)
In LBA mode this register contains the LBA bits 0–7. (L = 1)

Cylinder High/Low This indicates number of the first sector to be transferred. (L = 0)
In LBA mode this register contains the LBA bits 8–15 (Low) and bits 16–23 (High). (L = 1)

H This indicates the head number of the first sector to be transferred. (L = 0)
In LBA mode this register contains the LBA bits 24–27. (L = 1)

R This indicates the retry bit, but this bit is ignored.

Input parameters from the device

Sector Count This indicates the number of requested sectors not transferred. The Sector Count will be zero unless an unrecoverable error occurs.

Sector Number This indicates the sector number of the last transferred sector. (L = 0)
In LBA mode this register contains the current LBA bits 0–7. (L = 1)

Cylinder High/Low This indicates the cylinder number of the last transferred sector. (L = 0)
In LBA mode this register contains the current LBA bits 8–15 (Low) and bits 16–23 (High). (L = 1)

H This indicates the head number of the last transferred sector. (L = 0)
In LBA mode this register contains the current LBA bits 24–27. (L = 1)

13.37 Write Long (32h/33h)

Command Block Output Registers								Command Block Input Registers									
Register	7	6	5	4	3	2	1	0	Register	7	6	5	4	3	2	1	0
Data	-	-	-	-	-	-	-	-	Data	-	-	-	-	-	-	-	-
Feature	-	-	-	-	-	-	-	-	Error	see below							
Sector Count	0	0	0	0	0	0	0	1	Sector Count	-	-	-	-	-	-	-	V
Sector Number	V	V	V	V	V	V	V	V	Sector Number	V	V	V	V	V	V	V	V
Cylinder Low	V	V	V	V	V	V	V	V	Cylinder Low	V	V	V	V	V	V	V	V
Cylinder High	V	V	V	V	V	V	V	V	Cylinder High	V	V	V	V	V	V	V	V
Device/Head	1	L	1	D	H	H	H	H	Device/Head	-	-	-	-	H	H	H	H
Command	0	0	1	1	0	0	1	R	Status	see below							

Error Register							
7	6	5	4	3	2	1	0
CRC	UNC	0	IDN	0	ABT	T0N	AMN
0	0	0	V	0	V	0	0

Status Register							
7	6	5	4	3	2	1	0
BSY	RDY	DF	DSC	DRQ	COR	IDX	ERR
0	V	V	V	-	0	-	V

Figure 138. Write Long command (32h/33h)

The Write Long command transfers the data and the ECC bytes of the designated one sector from the host to the device, then the data and the ECC bytes are written to the disk media.

After 512 bytes of data have been transferred, the device will keep setting DRQ = 1 to indicate that the device is ready to receive the ECC bytes from the host. The data is transferred 16 bits at a time and the ECC bytes are transferred 8 bits at a time. The number of ECC bytes are either 4 or 40 according to setting of the Set Feature option. The default number after power on is 4 bytes.

Output parameters to the device

Sector Count This indicates the number of continuous sectors to be transferred. The Sector Count must be set to one.

Sector Number This indicates the sector number of the sector to be transferred. (L = 0)
In LBA mode this register contains the LBA bits 0–7. (L = 1)

Cylinder High/Low This indicates the cylinder number of the sector to be transferred. (L = 0)
In LBA mode this register contains the LBA bits 8–15 (Low) and bits 16–23 (High). (L = 1)

H This indicates the head number of the sector to be transferred. (L = 0)
In LBA mode this register contains the LBA bits 24–27. (L = 1)

R The retry bit, but this bit is ignored.

Input parameters from the device

Sector Count This indicates the number of requested sectors not transferred.

Sector Number This indicates the sector number of the sector to be transferred. (L = 0)
In LBA mode this register contains the current LBA bits 0–7. (L = 1)

Cylinder High/Low This indicates the cylinder number of the sector to be transferred. (L = 0)
In LBA mode this register contains current the LBA bits 8–15 (Low) and bits 16–23 (High). (L = 1)

H This indicates the head number of the sector to be transferred. (L = 0)
In LBA mode this register contains current the LBA bits 24–27. (L = 1)

The drive internally uses 40 bytes of ECC on all data read or writes. The 4-byte mode of operation is provided via an emulation technique. As a consequence of this emulation it is recommended that 40 byte ECC mode is used for all tests to confirm the operation of the ECC hardware of the drive. Unexpected results may occur if such testing is performed using 4-byte mode.

13.38 Write Multiple (C5h)

Command Block Output Registers								Command Block Input Registers									
Register	7	6	5	4	3	2	1	0	Register	7	6	5	4	3	2	1	0
Data	-	-	-	-	-	-	-	-	Data	-	-	-	-	-	-	-	-
Feature	-	-	-	-	-	-	-	-	Error	see below							
Sector Count	V	V	V	V	V	V	V	V	Sector Count	V	V	V	V	V	V	V	V
Sector Number	V	V	V	V	V	V	V	V	Sector Number	V	V	V	V	V	V	V	V
Cylinder Low	V	V	V	V	V	V	V	V	Cylinder Low	V	V	V	V	V	V	V	V
Cylinder High	V	V	V	V	V	V	V	V	Cylinder High	V	V	V	V	V	V	V	V
Device/Head	1	L	1	D	H	H	H	H	Device/Head	-	-	-	-	H	H	H	H
Command	1	1	0	0	0	1	0	1	Status	see below							

Error Register							
7	6	5	4	3	2	1	0
CRC	UNC	0	IDN	0	ABT	T0N	AMN
0	0	0	V	0	V	0	0

Status Register							
7	6	5	4	3	2	1	0
BSY	RDY	DF	DSC	DRQ	COR	IDX	ERR
0	V	V	V	-	0	-	V

Figure 139. Write Multiple command (C5h)

The Write Multiple command transfers one or more sectors from the host to the device. The data is then written to the disk media.

Command execution is identical to the Write Sectors command except that an interrupt is generated for each block as defined by the Set Multiple command instead of for each sector. The sectors are transferred through the Data Register 16 bits at a time.

Output parameters to the device

Sector Count This indicates the number of continuous sectors to be transferred. If the Sector Count of zero is specified, 256 sectors will be transferred.

Sector Number This indicates the sector number of the first sector to be transferred. (L = 0)
In LBA mode this register contains the LBA bits 0–7. (L = 1)

Cylinder High/Low This indicates the cylinder number of the first sector to be transferred. (L = 0)
In LBA mode this register contains the LBA bits 8–15 (Low) and bits 16–23 (High). (L = 1)

H This indicates the head number of the first sector to be transferred. (L = 0)
In LBA mode this register contains the LBA bits 24–27. (L = 1)

Input parameters from the device

Sector Count This indicates the number of requested sectors not transferred. The Sector Count will be zero, unless an unrecoverable error occurs.

Sector Number This indicates the sector number of the last transferred sector. (L = 0)
In LBA mode this register contains current the LBA bits 0–7. (L = 1)

Cylinder High/Low This indicates the cylinder number of the last transferred sector. (L = 0)
In LBA mode this register contains the current LBA bits 8–15 (Low) and bits 16–23 (High). (L = 1)

H This indicates the head number of the last transferred sector. (L = 0)
In LBA mode this register contains current the LBA bits 24–27. (L = 1)

13.39 Write Sectors (30h/31h)

Command Block Output Registers								Command Block Input Registers									
Register	7	6	5	4	3	2	1	0	Register	7	6	5	4	3	2	1	0
Data	-	-	-	-	-	-	-	-	Data	-	-	-	-	-	-	-	-
Feature	-	-	-	-	-	-	-	-	Error	see below							
Sector Count	V	V	V	V	V	V	V	V	Sector Count	V	V	V	V	V	V	V	V
Sector Number	V	V	V	V	V	V	V	V	Sector Number	V	V	V	V	V	V	V	V
Cylinder Low	V	V	V	V	V	V	V	V	Cylinder Low	V	V	V	V	V	V	V	V
Cylinder High	V	V	V	V	V	V	V	V	Cylinder High	V	V	V	V	V	V	V	V
Device/Head	1	L	1	D	H	H	H	H	Device/Head	-	-	-	-	H	H	H	H
Command	0	0	1	1	0	0	0	R	Status	see below							

Error Register							
7	6	5	4	3	2	1	0
CRC	UNC	0	IDN	0	ABT	T0N	AMN
0	0	0	V	0	V	0	0

Status Register							
7	6	5	4	3	2	1	0
BSY	RDY	DF	DSC	DRQ	COR	IDX	ERR
0	V	V	V	-	0	-	V

Figure 140. Write Sectors command (30h/31h)

The Write Sectors command transfers one or more sectors from the host to the device. The data is then written to the disk media.

The sectors are transferred through the Data Register 16 bits at a time.

If an uncorrectable error occurs, the write will be terminated at the failing sector, when the auto reassign function is disable.

Output parameters to the device

Sector Count This indicates the number of continuous sectors to be transferred. If the Sector Count of zero is specified, 256 sectors will be transferred.

Sector Number This indicates the sector number of the first sector to be transferred. (L = 0)
In LBA mode this register contains the LBA bits 0–7. (L = 1)

Cylinder High/Low This indicates the cylinder number of the first sector to be transferred. (L = 0)
In LBA mode this register contains the LBA bits 8–15 (Low) and bits 16–23 (High). (L = 1)

H This indicates the head number of the first sector to be transferred. (L = 0)
In LBA mode this register contains the LBA bits 24–27. (L = 1)

R This indicates the retry bit, but this bit is ignored.

Input parameters from the device

Sector Count This indicates the number of requested sectors not transferred. The Sector Count will be zero unless an unrecoverable error occurs.

Sector Number This indicates the sector number of the last transferred sector. (L = 0)
In LBA mode this register contains the current LBA bits 0–7. (L = 1)

Cylinder High/Low This indicates the cylinder number of the last transferred sector. (L = 0)
In LBA mode this register contains the current LBA bits 8–15 (Low) and bits 16–23 (High). (L = 1)

H This indicates the head number of the last transferred sector. (L = 0)
In LBA mode this register contains the current LBA bits 24–27. (L = 1)

13.40 Write Verify (3Ch: vendor specific)

In the implementation of the drive the Write Verify command is exactly the same as the Write Sectors command (30h). Read verification is not performed after the write operation.

Refer to 13.39, "Write Sectors Command" on page 187 for parameters.

This page intentionally left blank.

14.0 Time-out values

The timing of BSY and DRQ in Status Register are shown in the table below.

	INTERVAL	START	STOP	TIME-OUT
Power On	Device Busy After Power On	Power On	Status Register BSY=1	400 ns
	Device Ready After Power On	Power On	Status Register BSY=1 and RDY=1	31 sec
Software Reset	Device Busy After Software Reset	Device Control Register RST=1	Status Register BSY=1	400 ns
	Device Ready After Software Reset	Device Control Register RST=0 After RST=1	Status Register BSY=0 and RDY=1	31 sec
Hard Reset	Device Busy After Hard Reset	Bus RESET Signal Asserted	Status Register BSY=1	400 ns
	Device Ready After Hard Reset	Bus RESET Signal Asserted	Status Register BSY=0 and RDY=1	31 sec
Data In Command	Device Busy After Command Code Out	OUT To Command Register	Status Register BSY=1	400 ns
	Interrupt, DRQ For Data Transfer In	Status Register BSY=1	Status Register BSY=0 and DRQ=1, Interrupt	30 sec
	Device Busy After Data Transfer In	256th Read From Data Register	Status Register BSY=1	10 μ s
Data Out Command	Device Busy After Command Code Out	OUT to Command Register	Status Register BSY=1	400 ns
	Data Request For Data Transfer Out	Status Register BSY=1	Status Register BSY=0 and DRQ=1	700 μ s (Note 3)
	Device Busy After Data Transfer Out	256th Write From Data Register	Status Register BSY=1	5 μ s
	Interrupt For Data Transfer Out	Status Register BSY=1	Status Register BSY=0 and RDY=1 Interrupt	30 sec (Note 1)
Non-Data Command	Device Busy After Command Code Out	OUT to Command Register	Status Register BSY=1	400 ns
	Interrupt For Command Complete	Status Register BSY=1	Interrupt	30 sec (Note 2)
DMA Data Transfer Command	Device Busy After Command Code Out	OUT to Command Register	Status Register BSY=1	400 ns

Figure 141. Time-out values

Command category is referred to in section 12.0, "Command protocol" on page 97.

We recommend that the host system execute Soft reset and then retry to issue the command if the host system time-out would occur for the device.

Note 1. For SECURITY ERASE UNIT command, the execution time is referred to 13.22, "Security Erase Unit (F4h)" on page 146.

Note 2. For FORMAT UNIT command, the execution time is referred to 13.7, "Format Unit (F7h: Vendor Specific)" on page 116.

Note 3. When the initial power mode at power on is Standby mode, and when the following commands are issued by the host as First Command, the command's time-out value of the field is 10 seconds:

- Security Disable Password
- Security Erase Unit
- Security Set Password
- Security Unlock.

15.0 Appendix

15.1 Commands Support Coverage

The table below compares the command support coverage of the Travelstar 60GH & 40GN with the ATA-5 defined command set. The third column indicates the capability of the Travelstar 60GH & 40GN for those commands.

Command Code	Command Name	Implementation for Travelstar 60GH & 40GN	ATA-5 Category Type
00h	NOP	No	Optional
03h	CFA REQUEST EXTENDED ERROR CODE	No	Optional (Note 7)
08h	DEVICE RESET	No	Optional (Note 7)
1xh	RECALIBRATE	Yes	Obsoleted
20h	READ SECTOR(S)	Yes	Mandatory
21h	READ SECTOR(S)	Yes	Obsoleted
22h	READ LONG	Yes	Obsoleted
23h	READ LONG	Yes	Obsoleted
30h	WRITE SECTOR(S)	Yes	Mandatory
31h	WRITE SECTOR(S)	Yes	Obsoleted
32h	WRITE LONG	Yes	Obsoleted
33h	WRITE LONG	Yes	Obsoleted
38h	CFA TRANSLATE SECTORS W/O ERASE	No	Optional (Note 7)
3Ch	WRITE VERIFY (2)	Vendor specific	Obsoleted
40h	READ VERIFY SECTOR(S)	Yes	Mandatory
41h	READ VERIFY SECTOR(S)	Yes	Obsoleted
50h	FORMAT TRACK	Yes	Obsoleted
7xh	SEEK	Yes	Mandatory
87h	CFA TRANSLATE SECTORS	No	Optional
90h	EXECUTE DEVICE DIAGNOSTIC	Yes	Mandatory
91h	INITIALIZE DEVICE PARAMETERS	Yes	Mandatory
92h	DOWNLOAD MICROCODE	Reserved	Optional
94h-99h	Reserved	Reserved	Reserved
A0h	PACKET	No	Not to be used
A1h	IDENTIFY PACKET DEVICE	No	Not to be used
A2H	SERVICE	No	Not to be used
B0h	S.M.A.R.T. FUNCTION SET	Yes	Optional (Note 5)
C0h	CFA ERASE SECTORS	No	Optional
C4h	READ MULTIPLE	Yes	Mandatory
C5h	WRITE MULTIPLE	Yes	Mandatory
C6h	SET MULTIPLE MODE	Yes	Mandatory
C7h	READ DMA QUEUED	No	Optional
C8h	READ DMA	Yes	Mandatory
C9h	READ DMA	Yes	Obsoleted

Figure 142. Command coverage (1 of 2)

Command Code	Command Name	Implementation for Travelstar 60GH & 40GN	ATA-5 Command Type
CAh	WRITE DMA	Yes	Mandatory
CBh	WRITE DMA	Yes	Obsoleted
CCh	WRITE DMA QUEUED	No	Optional
CDh	CFA WRITE MULTIPLE W/O ERASE	No	Optional (Note 7)
DAh	GET MEDIA STATUS	No	Optional (Note 7)
DEh	MEDIA LOCK	No	Optional (Note 7)
DFh	MEDIA UNLOCK	No	Optional (Note 7)
E0h	STANDBY IMMEDIATE	Yes	Mandatory
E1h	IDLE IMMEDIATE	Yes	Mandatory
E2h	STANDBY	Yes	Mandatory
E3h	IDLE	Yes	Mandatory
E4h	READ BUFFER	Yes	Optional
E5h	CHECK POWER MODE	Yes	Mandatory
E6h	SLEEP	Yes	Mandatory
E7h	FLUSH CACHE	Yes	Mandatory
E8h	WRITE BUFFER	Yes	Optional
ECh	IDENTIFY DEVICE	Yes	Mandatory
EDh	MEDIA EJECT	No	Optional (Note 7)
EEh	IDENTIFY DEVICE DMA	No	Obsoleted
EFh	SET FEATURES	Yes	Mandatory
F0h	SENSE CONDITION	Vendor specific	Vendor specific
F1h	SECURITY SET PASSWORD	Yes	Optional (Note 6)
F2h	SECURITY UNLOCK	Yes	Optional (Note 6)
F3h	SECURITY ERASE PREPARE	Yes	Optional (Note 6)
F4h	SECURITY ERASE UNIT	Yes	Optional (Note 6)
F5h	SECURITY FREEZE LOCK	Yes	Optional (Note 6)
F6h	SECURITY DISABLE PASSWORD	Yes	Optional (Note 6)
F7h	FORMAT UNIT	Vendor specific	Vendor specific
F8h	READ NATIVE MAX ADDRESS	Yes	Optional
F9h	SET MAX ADDRESS	Yes	Optional
FAh	ENABLE/DISABLE DELAYED WRITE	Yes	Vendor specific
FB-FFh	Vendor specific	Reserved	Vendor specific
	Reserved: all remaining codes	Reserved	Reserved

Figure 143. Command coverage (2 of 2)

Note 1. These commands have two command codes and appear in this table twice, once for each command code.

Note 2. The WRITE VERIFY command implemented vendor specific. The operation is the same as WRITE SECTORS and verification is not performed.

Note 3. Protected Area Feature Set

Note 4. Power Management Feature Set

Note 5. S.M.A.R.T. Function Set

Note 6. Security Mode Feature Set

Note 7. Removable

15.2 SET FEATURES Command Support Coverage

The following table provides a list of Feature Registers, Feature Names, and implementation for the Travelstar 60GH & 40GN. The third column indicates whether or not the Travelstar 60GH & 40GN has the capability of executing the command in comparison to the ATA-4 defined command set. For detailed operation, refer to section 13.28, "Set Features (EFh)" on page 155.

Features Register	Features Name	Implementation for Travelstar 60GH & 40GN
02h	Enable write cache	Yes
03h	Set transfer mode	Yes
05h	Enable Advanced Power Management	Yes
09h	Enable Address Offset mode	Yes
44h	Set vendor specific bytes ECC	Yes
55h	Disable read look-ahead feature	Yes
5Dh	Enable release interrupt	No
5Eh	Enable SERVICE interrupt	No
66h	Disable reverting to power on defaults	Yes
82h	Disable write cache	Yes
85h	Disable Advanced Power Management	Yes
89h	Disable Address Offset mode	Yes
95h	Enable Media Status Notification	No
AAh	Enable read look-ahead feature	Yes
BBh	Set 4 bytes ECC	Yes
CCh	Enable reverting to power on defaults	Yes
DDh	Disable release interrupt	No
ECh	Disable SERVICE interrupt	No
others	Reserved	Reserved

Figure 144. SET FEATURES command coverage

15.3 Changes from Travelstar 48GH, 30GN & 15GN

The Travelstar 60GH & 40GN has changed one feature present in the Travelstar 48GH, 30GN & 15GN:

- The identify device information data.

Index

A

ABRT, 71
Address Offset Feature, 93
Address setting, 58
Auto Reassign Function, 97
 Nonrecovered read errors, 97
 Recovered read errors, 97
Automatic power down sequence, 180
Average latency, 16
Average seek time, 15

C

Check Power Mode, 109
Command
 Check Power Mode (E5h/98h), 109
 Enable/Disable Delayed Write (FAh), 114
 Execute Device Diagnostic (90h), 115
 Flush Cache (E7h), 116
 Format Track (50h), 117
 Identify Device (ECh), 120
 Idle (E3h/97h), 129
 Idle Immediate (E1h/95h), 130
 Initialize Device Parameters (91h), 131
 Read Buffer (E4h), 132
 Read DMA (C8h/C9h), 133
 Read Long (22h/23h), 135
 Read Multiple (C4h), 137
 Read Native Max ADDRESS (F8h), 139
 Read Sectors (20h/21h), 141
 Read Verify Sectors (40h/41h), 143
 Recalibrate (1xh), 145
 S.M.A.R.T. Function Set (B0h), 163
 Security Disable Password (F6h), 146
 Security Erase Prepare (F3h), 147
 Security Erase Unit (F4h), 148
 Security Freeze Lock (F5h), 150
 Security Set Password (F1h), 151
 Security Unlock (F2h), 153
 Seek (7xh), 155
 Set Features (EFh), 157
 Set Max ADDRESS (F9h), 159
 Set Multiple (C6h), 161
 Sleep (E6h/99h), 162
 Standby (E2h/96h), 180

 Standby Immediate (E0h/94h), 181
 Write Buffer (E8h), 182
 Write DMA (CAh/CBh), 183
 Write Long (32h/33h), 185
 Write Multiple (C5h), 187
 Write Sectors (30h/31h), 189
 Write Verify (3Ch), 191
Command descriptions, 105
Command protocol, 99
Command table, 88
Commands Support Coverage, 195
Conductive noise, 24

D

DC power requirements, 25
Default Register Values, 75
Delayed Write, 96
Device Attribute Data Structure, 168
Diagnostic Codes, 75
Drive ready time, 16

E

Electromagnetic compatibility, 39
Enable/Disable Delayed Write command, 96
Environmental condition, 23
Error Register
 Diagnostic Codes, 75
Example for operation (In LBA Mode), 90
Execute Device Diagnostic, 115

F

Flush Cache, 116
Format Track, 117
Format Unit (F7h: vendor specific), 118
Full stroke seek, 15

I

Identify Device, 99, 120
Idle, 103, 129
Idle Immediate, 130
Individual Attribute Data Structure, 169
Initial Power Mode at Power On, 81
Initialize Device Parameters, 131
Interface Capability for Power Modes, 81
Interface logic signal levels, 47

M

Magnetic flux density limits, 24
Master Password, 84
Master Password Revision Code, 85

N

Nonrecovered read errors, 97
Nonrecovered write errors, 20, 97

O

Operating modes, 17

P

PIO timings, 48
Power management, 80
Power Management Feature
 Initial Power Mode at Power On, 81
 Power Management Commands, 80
 Power mode, 80
 Standby timer, 81
 Standby/sleep command completion timing, 80
 Status, 81
Power-off considerations, 77
 Emergency unload, 77
 Load/Unload, 77
 Required power-off sequence, 78
Protected Area, 90

R

Radiation noise, 24
Read Buffer, 99
Read Buffer (E4h), 132
Read DMA, 104, 133
Read Long, 99, 135
Read Multiple, 99, 137
Read Native Max ADDRESS, 103, 139
Read Sectors, 99, 141
Read Verify Sectors, 103, 143
Reassign Function, 97
Recalibrate, 103, 145
Recovered read errors, 20, 97
Register
 Alternate status register, 68
 Command register, 68
 Cylinder high register, 68
 Cylinder low register, 68
 Data register, 69
 Device control register, 69
 Device/head register, 70
 Drive address register, 70
 Error register, 71

Features register, 71
Sector Count Register, 71
Sector Number Register, 72
Status Register, 72

Register Set, 67

Reset

 Diagnostic and reset considerations, 76
 Register initialization, 75

Reset error register values, 76

Reset timings, 47

S

S.M.A.R.T.

 S.M.A.R.T. operation with power management modes, 83

S.M.A.R.T. Capability, 172

S.M.A.R.T. function, 82

 Attribute thresholds, 82

 Attribute values, 82

 Attributes, 82

 S.M.A.R.T. commands, 82

 Threshold exceeded condition, 82

S.M.A.R.T. Function Set, 163

S.M.A.R.T. Function Subcommands, 164

Safety, 40

Sector Addressing Mode, 78

 LBA addressing mode, 79

 Logical CHS addressing mode, 78

Security, 84

Security Disable Password, 101, 146

Security Erase Prepare, 103, 147

Security Erase Unit, 101, 148

Security Freeze Lock, 103, 150

Security Mode Feature Set, 84

Security Set Password, 101, 151

SECURITY UNLOCK, 87, 101, 153

Seek, 103, 155

Seek Overlap, 95

Service life and usage condition, 28

Set Features, 103, 157

SET FEATURES Command Support Coverage,
 197

Set Max ADDRESS, 103, 159

Set Multiple, 161

Set Multiple Mode, 103

Shock, 34

Single track seek time, 16

Sleep, 17, 103, 162

SMART Disable Operations, 103

SMART Enable Operations, 103

SMART Enable/Disable Attribute Autosave, 103

SMART Execute Off-line Immediate, 103

SMART Read Attribute Thresholds, 99

SMART Read Attribute Values, 99
SMART Return Status, 103
SMART Save Attribute Values, 103
Sound power level, 37
Standby, 103, 180
Standby Immediate, 103, 181
Standby timer, 81
Standby/Sleep command completion timing, 80

T

Table of signals, 42
Time-out interval, 129
Time-out Parameter, 129, 130
Time-out values, 193

U

User Password, 84

V

Vibration, 34

W

Write Buffer, 101, 182
Write Cache, 19, 96
Write DMA, 104, 183
Write Long, 101, 185
Write Multiple, 101, 187
Write Sectors, 101, 189
Write Verify, 101, 191



© International Business Machines Corporation 2002

www.ibm.com/harddrive

IBM Technology Group Support Center

Telephone: 888.IBM.5214 or 507.286.5825

E-mail: drive@us.ibm.com

Singapore Technology Group Support Center

Telephone: 1800.418.9595 or (65)6418.9595

E-mail: drive@sg.ibm.com

UK Technology Group Support Center

Telephone: 44.1475.898.125

E-mail: drive@uk.ibm.com

Germany Technology Group Support Center

Telephone: 49.7032.153050

E-mail: drive@de.ibm.com

IBM Storage Systems Division

5600 Cottle Road

San Jose, CA 95193

www.ibm.com/storage

Printed in the United States of America

05-2002

All Rights Reserved

IBM is a registered trademark of International Business Machines Corporation. Other company, product, and service names may be trademarks or service marks of others.

Product description data represents IBM's design objectives and is provided for comparative purposes; actual results may vary depending on a variety of factors. Product claims are true as of the date of the first printing. This product data does not constitute a warranty. Questions regarding IBM's warranty terms or the methodology used to derive this data should be referred to an IBM representative. Data subject to change without notice.

References in this publication to IBM products, programs, or services do not imply that IBM intends to make them available in all countries in which IBM operates.

Document # S07N-7715-03

Publication # 1541
