

Product summary

Ultrastar 9LZX & 18ZX

FC-AL



Models: DRVL-18L
DRVL-09L

Introducing

IBM has introduced a new range of Fibre Channel drives intended for advanced storage applications which demand fast access to large amounts of data. The Ultrastar 9LZX and 18ZX offer a rotational speed of 10,000 RPM, embedded sector servo, S.M.A.R.T., PRML, and a minimum sustained data transfer rate of 200 MB/sec.

Applications

- Technical/commercial workstations
- Network servers
- Mass storage arrays
- High-end personal computers
- Large scale imaging and graphics
- Video servers
- Video editing

Features

- 9.1 GB and 18.2 GB formatted capacity
- Dual 1.06 Gb/s Fibre Channel Arbitrated Loop
- 15.2 to 20.3 MB/s Sustained data transfer rate
- 23.4 - 30.46 MB/sec media transfer rate (peak)
- Rotational speed of 10,000 RPM
- Average read seek time 5.3 ms (9.1 MB)
6.5 ms (18.2 ms MB)
- Latency 2.99 ms
- 4 MB multi-segmented cache buffer
- Low command overhead
- Read ahead caching
- ECC on the fly (EOTF)
- No-ID sector formatting
- PRML data channel
- Predictive Failure Analysis™ (PFA™)

Benefits

- Range of capacities to meet the need for increasing storage requirements
- Fast interface data rate: 200 MB/sec
- High data rate across entire disk surface
- Fast access to data
- Fast data retrieval in single and multi-tasking applications
- Improved data throughput
- More data stored per track, increased sustained data transfer rate
- High reliability and availability

 **ATTENTION:** The drive must be protected against electrostatic discharge especially when being handled. The safest way to avoid damage is to put the drive in an antistatic bag before an ESD wrist strap is removed. Drives should only be shipped in approved containers. Severe damage can be caused to the drive if the packaging does not adequately protect against the shock levels induced when a box is dropped. Consult your IBM representative if you do not have an approved shipping container.

FC-AL electrical connector

The electrical connector is located as shown.

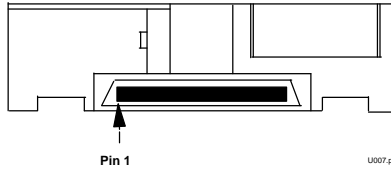

40-Pin SCA-2 SFF-8045 FC-AL connector definition

The Ultrastar 9LZX and 18ZX use the 40 pin SCA-2 connector defined by the ANSI SFF-8045 specification. The SFF-8067 specification is also supported. The connector allows for plugging a drive directly into a back plane by providing the necessary electrical connections. Mechanical stability and device retention must be provided by other mechanisms outside the drive. There are many signals defining the 40 pin connector and several definitions are included in the following text.

Signal Name	Connector Contact Number		Signal Name
-ENBL BYP CH1	1	21	12 V dc Charge
12 Volts dc	2	22	12 V dc Ground
12 Volts dc	3	23	12 V dc Ground
12 Volts dc	4	24	+Port 1_In
-Parallel ESI	5*	25	-Port 1_In
-Drive Present	6	26	12 V dc Ground
Ready LED Out	7	27	+Port 2_In
Spindle Sync	8	28	-Port 2_In
Start_1/Mated	9	29	12 V dc Ground
Start_2/Mated	10	30	+Port 1_Out
-ENBL BYP CH2	11	31	-Port 1_Out
Sel_6/ -EFW	12*	32	5 V/3.3 V dc Ground
Sel_5/ -P_ESI_5	13*	33	+Port 2_Out
Sel_4/ -P_ESI_4	14*	34	-Port 2_Out
Sel_3/ -P_ESI_3	15*	35	5V/3.3V dc Ground
Fault LED Out	16	36*	Sel_2/ -P_ESI_2
OPT 3.3 Volts dc	17	37*	Sel_1/ -P_ESI_1
OPT 3.3 Volts dc	18	38*	Sel_0/ -P_ESI_0
5 Volts dc	19	39	OPT 3.3 V dc Charge
5 Volts dc	20	40	5 V dc Charge

Notes: The 3.3 V contacts are not connected in the drive. The Guide Pins are connected to 5 V/3.3 V ground.

*The definition changes for the ANSI SFF-8067 40-pin SCA-2 connector. Refer to the Ultrastar 9LZX & 18ZX FC-AL hardware/functional specifications for the details.

Voltage and ground signals

The +12 V dc and +5 V dc voltage contacts provide all of the voltages required by the drive. The two voltages share a common ground plane to which all of the ground contacts are connected. The 3.3 V dc contacts are left open.

Spindle sync

Spindle sync (connector pin 8) is not supported by this drive.

Fault LED out

The Fault LED is driven by the following conditions:

- both enable bypass signals are asserted by the drive
- an internal failure has been detected by the drive
- the drive has been instructed by the host to turn on the LED

The drive provides an open-collector transistor-transistor logic (TTL) driver with up to 30 mA of current sink capability to the drive Fault LED. The cathode of the LED is connected to this signal. The LED and the current-limiting resistor must be provided by the enclosure.

Ready LED out

The Ready LED has the following indications (per the Hot Plug implementation):

- *Drive not mated*: The signal is de-asserted, that is, high. The LED is off.
- *Drive mated, motor not spinning*: The LED is generally off. The LED is turned on long enough to be seen by an observer whenever a SCSI command is received.
- *Drive mated, spinning up or spinning down*: The LED is flashing with an equal on and off period of 1/2 second.

- *Drive mated, motor spinning*: The signal is normally on continuously. Whenever a SCSI command is received, the signal is off long enough to be seen by an observer.

The drive provides an open-collector TTL driver with up to 30 mA of current sink capability to drive the Ready LED. The cathode of the LED is connected to this signal. The LED and the current-limiting resistor must be provided by the enclosure.

Start_X/Mated controls (pins 9 and 10)

These two signals are TTL inputs to the drive and have associated 10 KOhm resistors. The following table shows the logic combinations and motor spin functions that can be created.

Start_2 Mated	Start_1 Mated	Motor spin function
Open	Open	Drive is not mated. No spin-up will occur.
Open	GND	The motor will spin up with the SCSI Unit Start Command.
GND	Open	The motor will spin up after a delay of 12 times the modulo 8 value of Sel_ID (in seconds).
GND	GND	The motor will spin up after drive initialization.

SEL_n and enclosure service signals

These signals have different definitions depending on the state of **-Parallel ESI** (pin 5) and the level of

enclosure service supported by the back plane. When **-Parallel ESI** is de-asserted (high), the back plane must present SEL_ID information on these signals (within 1 us). When **-Parallel ESI** is asserted (low), the back plane (if supported) will present enclosure service information on these signals (within 1 us). The drive will then go through a discovery phase to determine the level of enclosure services that the back plane supports (for example; none, SFF-8045, or SFF-8067) and behave accordingly. Seven signals define 128 possible values and are directly translated into an Arbitrated Loop Physical Address (AL-PA). The drive will attempt to acquire the data for its own during part of the loop initialization process of the drive.

-ENBL BYP CH1, -EnBL BYP CH2

These TTL outputs from the drive provide up to 4 mA of sink current. The outputs are intended to control the state of a loop port bypass circuit on the back plane. The drive powers up with these signals turned off. The back plane must provide a 10 KOhm pull-up resistor that will ensure that the drive is bypassed on the loop when it is not present or when it is powering up. After a successful power-up, the drive will attempt to enable itself on both loops (if allowed to do so via SCSI mode page 0x19). These signals are also controllable by the host with the LPB and LPE Fibre Channel primitives command sequence.

-Drive Present

This signal is connected to the drive's ground plane. The back plane can use this signal to detect the presence of a drive.

Front option jumper block

Jumper position and function are shown below.

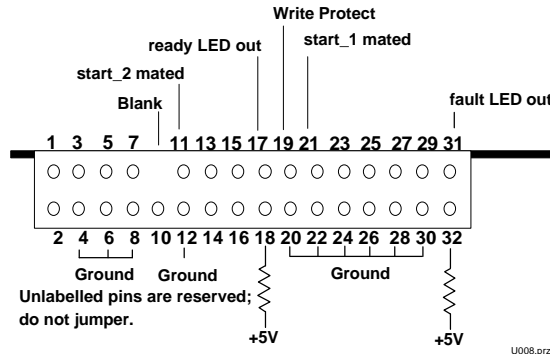

Ultrastar 9LZX/18ZX models contain a **Front Option Jumper Block** that can be used to enable optional features. The jumper block provides some useful features not available in SFF-8045, and also provides an alternate means of options access.

The Option Block connector (2x16) is an AMP connector (PN 84156-5) having a pin spacing of 2 mm.

Data organization

Number of disks	10
Number of heads	20

Total usable data bytes (512 logic blocks)

9.1 GB	9,179,493,376 B
18.2 GB	18,370,117,120 B

Seek times (in milliseconds)

Ultrastar 9LZX

Average weighted	Read	5.3
	Write	6.7
Full stroke	Read	11.5
	Write	13.5

Ultrastar 18ZX

Average weighted	Read	6.5
	Write	7.5
Full stroke	Read	13.5
	Write	15.0

DC Power requirement limits

The following voltage specifications apply at the drive power connector. There are no special power on/off sequencing requirements.

+5 V dc supply	±5% during run and spin up
+12 V dc supply	±5% during run ±5 to 7% during spin up

Power supply current +5 V dc

	9.1 GB Pop. mean (A)	18.2 GB Pop. mean (A)
Idle average	0.76 ± 10%	0.76 ± 10%

Power supply current +12 V dc

	9.1 GB Pop. mean (A)	18.2 GB Pop. mean (A)
Idle average	0.66 ± 10%	1.18 ± 10%
Seek peak (maximum)	2.1	2.7
Spin-up	2	3.5

Notes:

1. 5 V current is given with termination power provided by the using system.
2. The current at start is the total 12 volt current required (i.e. the motor start current, module current and voice coil retract current).

Externally generated (as seen at power connector)

Voltage (V dc)	Maximum (mV p-p)	Notes
+5	250	0–20 MHz
	650	0–100 Hz
+12	400	100–5,000 Hz
	250	5 KHz–20 MHz

During drive start up and seeking, 12 volt ripple is generated by the drive (referred to as dynamic

loading). If the power of several drives is daisy chained together, the power supply ripple as well as the dynamic loading of other drives must remain within the regulation tolerance window of ±5%. A more desirable method of power distribution is a common supply with separate power leads to each drive.

Hot Plug/Unplug support

Back plane hot plug and unplug is allowed for both FC-AL models. It is assumed that port bypasses are active on both FC-AL ports, and that they are both enabled during the plug or unplug event.

During a hot plug-in event the drive will draw a large amount of current when it is plugged in because of the charging of the bypass capacitors on the drive. This current pulse may cause the power supply to go out of regulation. If this supply is shared by other drives, a low voltage power-on reset may be initiated on those drives. Never daisy-chain the power leads if hot plugging is planned. Hot plugging should be minimized to prevent wear on the power pins of the connector.

If allowed to do so the drive will un-bypass itself on both ports and LIP via the protocol-specific SCSI Mode Page 19 after a plug-in event.

During hot plugging, the supplies must not exceed the drive's upper voltage limit. Proper ESD protection must be used during the plugging event. If the drive's operating shock limit specification can be exceeded during hot unplugging, then the drive should be spun down completely before it is unplugged.

Start and stop times

9.1 GB Model

Time	Nominal (seconds)	Worst case* (seconds)
Power Up	3.3	3.8
Start-Up	15.6	24.6
Spin-Up	9	11.3
Servo Recal	6.1	7.2
Bats2 /Reassign	0.5	1

*Worst case represents a 3-sigma event.

18.2 GB Model

Time	Nominal (seconds)	Worst case (seconds)
Power Up	3.3	3.8
Start-Up	20.9	29.4
Spin-Up	10.7	13
Servo Recal	9.7	10.8
Bats2 /Reassign	0.5	1

Bring-up sequence times and stop time

See the illustration on this page.

A full Bring-up sequence consists of

a Power-up sequence and Startup sequence.

Power On is the length of time required for the power at the drive to meet the power specifications for the drive.

The Startup sequence spins up the spindle motor, initializes the servo subsystem, performs the Basic Assurance Tests 2 (BATS2) verifying the read-write hardware, resumes *Reassign in Progress* operations and more.

If configured to do so, the drive will enable itself on both FC-AL loops at the end of power-up (auto-start disabled) or at the end of startup (auto-start enabled).

If a *Target Reset* SCSI task management function is issued while the drive is in either a Power-Up or Startup Sequence, that same sequence starts again. In all other cases when a *Target Reset* is issued, the present state of the motor is not altered.

A startup sequence initiated by SCSI *Start/Stop Unit* command that follows a spindle stop initiated by a SCSI *Start/Stop Unit* command by less than 10 seconds may result in the startup sequence increasing by as much as 10 seconds. For example, if a delay of only 3 seconds exists between the two commands, the second command takes 7 seconds longer than if 10 seconds or more had been allowed between the commands.

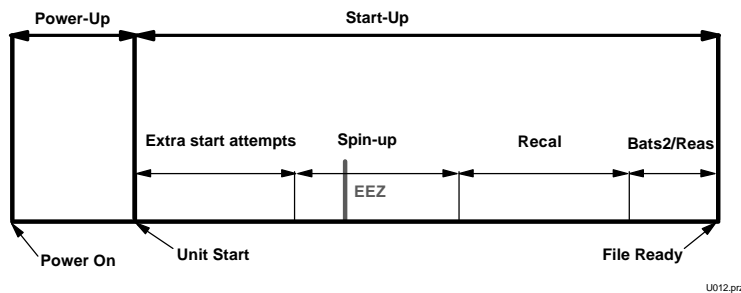

Operating environment

The drive operates within its performance limits when the following environment is maintained. Product life calculations are based on the nominal environment for a typical application.

Temperature

Operating Ambient	5 to 50°C
Operating Disk Enclosure (Ultrastar 9LZX)	5 to 65°C
Operating Disk Enclosure (Ultrastar 18ZX)	5 to 60°C
Storage	1 to 65°C—see IBM TR 07.2112 for storage below 1°C
Shipping	-40 to 65°C
Max. gradient	20°C/hour

Temperature Gradient

Operating	20°C per hour
Shipping and Storage	Below condensation

These temperature limits are extremely important and must not be exceeded at the worst case drive and system operating conditions with the drive randomly seeking, reading, and writing.

Relative humidity

Operating	5 to 90%
Storage	5 to 90%
Shipping	5 to 95%

Wet bulb temperature (noncondensing)

Operating	26.7°C maximum
Nonoperating	29.4°C maximum

Elevation

Operating and Storage	-304.8 to 3,048 m
Shipping	-304.8 to 12,192 m

Vibration and shock

Operating/nonoperating vibration

Due to the complexity of this subject, we recommend that users contact the distributor to discuss how to perform the required measurements if they believe this to be an area which requires evaluation.

Operating shock

No permanent damage will occur to the drive when subjected to a 10 G half sine wave shock pulse of 11 ms duration. The shock pulses are applied in each of three mutually perpendicular axes, one axis at a time.

Nonoperating shock

Translational shock

1.0 inch and 1.6 inch models will not suffer hard errors or acoustic degradation if the unpackaged drive is subjected to a 180 in/sec velocity change square pulse shock of 50 Gs or less applied to all three axes, one direction at a time.

1.0 inch models will not suffer hard errors or acoustic degradation if the unpackaged drive is subjected to a 2 ms half sine pulse shock of 150 Gs or less applied to all three axes, one direction at a time.

1.6 inch models will not suffer hard errors if the unpackaged drive is subjected to a 2 ms half sine pulse shock of 140 Gs or less applied to all three axes, one direction at a time.

Rotational shock

The actuator will remain latched in the disk landing zone if the unpackaged drive is subjected to a 2 ms half sine wave shock less than 15,000 radians per second squared applied to the XY plane.

Acoustics

Model	Idle level max. (Bel)
9.1 GB	4.4
18.2 GB	5.0

The population average of the sound pressure measured one meter above the center of the drive in idle mode will not exceed 4.1 Bels.

Mechanical specifications

Dimensions	S.I. Metric
Ultrastar 9LZX	
Weight	0.67±10%
(mm)	
Height	25.70
Width	101.60
Length	146.75
Ultrastar 18ZX	
Weight	1.05 ±10%
(mm)	
Height	41.48
Width	101.60
Length	146.75

Clearance

A minimum of 2 mm clearance should be given to the bottom surface except for a 10 mm maximum diameter area around the bottom mounting holes.

There should be 7 mm of clearance between the drives that are mounted with their top sides facing each other. Drives from other manufactures may require additional spacing due to stray magnetic fields.

Note: For proper cooling it is suggested that a minimum clearance of 7 mm be provided under the drive and on top of the drive.

Mounting

Refer to the Hardware/Functional Specification Drive Mounting Guidelines for more details on how to mount the drive. The diagrams below show the location of mounting holes. The drive has both side and bottom mounting holes and can be mounted with any surface facing down.

The recommended torque to be applied to the mounting screws is 0.8 ± 0.2 Newton-meters.

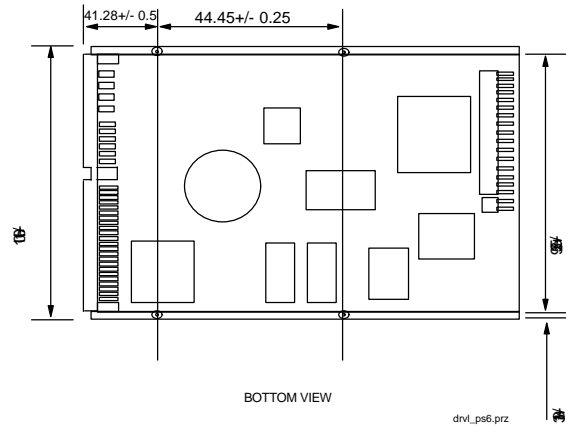
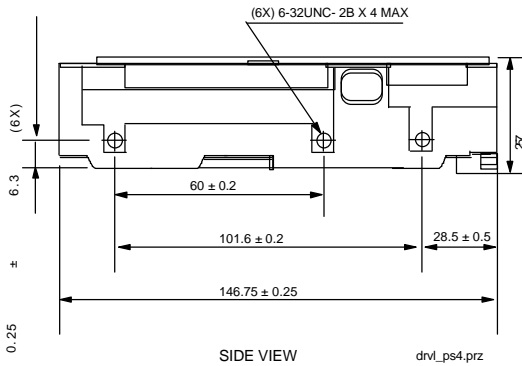

Location of side and bottom mounting holes.

Note: All measurements are in millimeters. Clearance is 7 mm.



© International Business Machines Corporation 2000
www.ibm.com/harddrive

IBM Hard Disk Drive Technical Support Center

Telephone: 888.IBM.5214 or 507.253.4110
E-mail: drive@us.ibm.com

Singapore Technical Support Center

Telephone: 65.1800.840.9292
E-mail: drive@sg.ibm.com

UK Technical Support Center

Telephone: 44.1475.898.125
E-mail: drive@uk.ibm.com

Germany Technical Support Center

Telephone: 49.7032.153050
E-mail: drive@de.ibm.com

IBM Systems Storage Division

5600 Cottle Road
San Jose CA 95193
www.ibm.com/storage

Printed in the United States of America
05-2000

All Rights Reserved

IBM, Drive-TIP, No-ID, and Predictive Failure Analysis are the registered trademarks of International Business Machines Corporation.

Other company, product, and service names may be trademarks or service marks of others.

Produced by the IBM Hard Disk Drive Technical Support Center.

Ultrastar 9LZX & 18ZX FC-AL Hard Disk Drive Hardware and functional specification, 1 March 1999.

This product summary is not a substitute for the full production specification, which should be used when detailed information is required.

Product Description data represents IBM's design objectives and is provided for comparative purposes; actual results may vary based on a variety of factors. This product data does not constitute a warranty. Questions regarding IBM's warranty terms or methodology used to derive this data should be referred to the IBM Hard Disk Drive Technical Support Center. Data subject to change without notice.

Date: 5 June 2000